

18. Diagnostic Procedure with Diagnostic Trouble Code (DTC)

A: DTC P0011 — “A” CAMSHAFT POSITION-TIMING OVER-ADVANCED OR SYSTEM PERFORMANCE (BANK 1) —

DTC DETECTING CONDITION:

Immediately at fault recognition

TROUBLE SYMPTOM:

- Engine stalls.
- Erroneous idling

CAUTION:

After repair or replacement of faulty parts, conduct Clear Memory Mode <Ref. to EN(H4DOTC)-44, OPERATION, Clear Memory Mode.> and Inspection Mode <Ref. to EN(H4DOTC)-36, Inspection Mode.>.

Step	Check	Yes	No
<p>1</p> <p>CHECK ANY OTHER DTC ON DISPLAY.</p>	<p>Is any other DTC displayed?</p>	<p>Inspect the relevant DTC using “List of Diagnostic Trouble Code (DTC)”. <Ref. to EN(H4DOTC)-68, List of Diagnostic Trouble Code (DTC).></p>	<p>Go to step 2.</p>
<p>2</p> <p>CHECK CURRENT DATA.</p> <p>1) Start the engine and let it idle. 2) Inspect the VVT advance timing and OCV duty output using Subaru Select Monitor and OBD-II general scan tool.</p> <p>NOTE:</p> <ul style="list-style-type: none"> • Subaru Select Monitor <p>For detailed operation procedure, refer to the “READ CURRENT DATA FOR ENGINE”. <Ref. to EN(H4DOTC)-29, Subaru Select Monitor.></p> <ul style="list-style-type: none"> • OBD-II general scan tool <p>For detailed operation procedures, refer to the OBD-II General Scan Tool Instruction Manual.</p>	<p>Is the VVT advance timing more than approx. 0°C and the OCV duty output more than approx. 10%?</p>	<p>Inspect the following items and repair or replace if necessary.</p> <ul style="list-style-type: none"> • Engine oil (amount, contamination) • Oil pipe (clog) • Oil flow control solenoid valve (clog or contamination in oil passage, settling at spring, stuck at valve) • Intake camshaft (sludge, damage at camshaft) • Timing belt (timing mark aligning) 	<p>A temporary malfunction. Conduct the following to clean the oil passage. Replace the engine oil and idle the engine for 5 minutes, then replace the oil filter and engine oil.</p>

DIAGNOSTIC PROCEDURE WITH DIAGNOSTIC TROUBLE CODE (DTC)

ENGINE (DIAGNOSTICS)

B: DTC P0021 — “A” CAMSHAFT POSITION-TIMING OVER-ADVANCED OR SYSTEM PERFORMANCE (BANK 2) —

DTC DETECTING CONDITION:

Immediately at fault recognition

TROUBLE SYMPTOM:

- Engine stalls.
- Erroneous idling

CAUTION:

After repair or replacement of faulty parts, conduct Clear Memory Mode <Ref. to EN(H4DOTC)-44, OPERATION, Clear Memory Mode.> and Inspection Mode <Ref. to EN(H4DOTC)-36, OPERATION, Inspection Mode.>.

Step	Check	Yes	No
1 CHECK ANY OTHER DTC ON DISPLAY.	Is any other DTC displayed?	Inspect the relevant DTC using “List of Diagnostic Trouble Code (DTC)”. <Ref. to EN(H4DOTC)-68, List of Diagnostic Trouble Code (DTC).>	Go to step 2.
2 CHECK CURRENT DATA. 1) Start the engine and let it idle. 2) Inspect the VVT advance timing and OCV duty output using Subaru Select Monitor and OBD-II general scan tool. NOTE: • Subaru Select Monitor For detailed operation procedure, refer to the “READ CURRENT DATA FOR ENGINE”. <Ref. to EN(H4DOTC)-29, Subaru Select Monitor.> • OBD-II general scan tool For detailed operation procedures, refer to the OBD-II General Scan Tool Instruction Manual.	Is the VVT advance timing more than approx. 0°C and the OCV duty output more than approx. 10%?	Inspect the following items and repair or replace if necessary. • Engine oil (amount, contamination) • Oil pipe (clog) • Oil flow control solenoid valve (clog or contamination in oil passage, settling at spring, stuck at valve) • Intake camshaft (sludge, damage at camshaft) • Timing belt (timing mark aligning)	A temporary malfunction. Conduct the following to clean the oil passage. Replace the engine oil and idle the engine for 5 minutes, then replace the oil filter and engine oil.

DIAGNOSTIC PROCEDURE WITH DIAGNOSTIC TROUBLE CODE (DTC)

ENGINE (DIAGNOSTICS)

C: DTC P0030 — HO₂S HEATER CONTROL CIRCUIT (BANK 1 SENSOR 1) — DTC DETECTING CONDITION:

- Two consecutive driving cycles with fault
- GENERAL DESCRIPTION <Ref. to GD(H4DOTC)-12, DTC P0030 — HO₂S HEATER CONTROL CIRCUIT (BANK 1 SENSOR 1) —, Diagnostic Trouble Code (DTC) Detecting Criteria.>

CAUTION:

After repair or replacement of faulty parts, conduct Clear Memory Mode <Ref. to EN(H4DOTC)-44, OPERATION, Clear Memory Mode.> and Inspection Mode <Ref. to EN(H4DOTC)-36, OPERATION, Inspection Mode.>.

WIRING DIAGRAM:

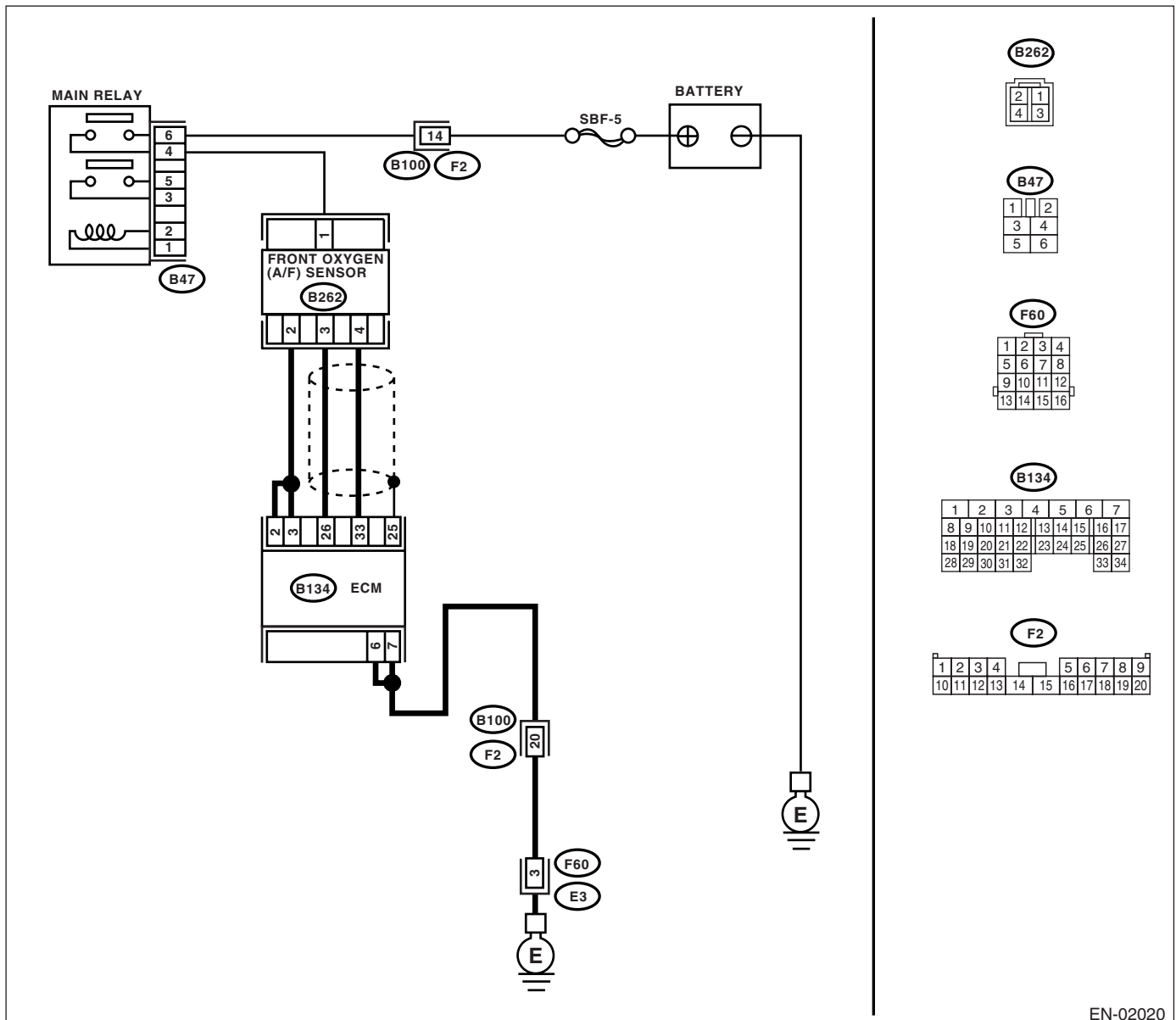

EN-02020

DIAGNOSTIC PROCEDURE WITH DIAGNOSTIC TROUBLE CODE (DTC)

ENGINE (DIAGNOSTICS)

Step	Check	Yes	No
1 CHECK HARNESS BETWEEN ECM AND FRONT OXYGEN (A/F) SENSOR CONNECTOR. 1) Start the engine and warm-up engine. 2) Turn the ignition switch to OFF. 3) Disconnect the connectors from ECM and front oxygen (A/F) sensor. 4) Measure the resistance of harness between ECM and front oxygen (A/F) sensor connector. <i>Connector & terminal</i> (B134) No. 2 — (B262) No. 2: (B134) No. 3 — (B262) No. 2:	Is the resistance less than 1 Ω ?	Go to step 2.	Repair the open circuit in harness between ECM and front oxygen (A/F) sensor connector.
2 CHECK HARNESS BETWEEN ECM AND FRONT OXYGEN (A/F) SENSOR CONNECTOR. Measure the resistance of harness between ECM and front oxygen (A/F) sensor connector. <i>Connector & terminal</i> (B134) No. 26 — (B262) No. 3: (B134) No. 33 — (B262) No. 4:	Is the resistance less than 1 Ω ?	Go to step 3.	Repair the open circuit in harness between ECM and front oxygen (A/F) sensor connector.
3 CHECK HARNESS BETWEEN ECM AND FRONT OXYGEN (A/F) SENSOR CONNECTOR. Measure the resistance of harness between main relay and front oxygen (A/F) sensor connector. <i>Connector & terminal</i> (B47) No. 4 — (B262) No. 1:	Is the resistance less than 1 Ω ?	Go to step 4.	Repair the open circuit in harness between ECM and front oxygen (A/F) sensor connector.
4 CHECK FRONT OXYGEN (A/F) SENSOR. Measure the resistance between front oxygen (A/F) sensor connector terminals. <i>Terminals</i> No. 1 — No. 2:	Is the resistance less than 5 Ω ?	Go to step 5.	Replace the front oxygen (A/F) sensor. <Ref. to FU(H4DOTC)-37, Front Oxygen (A/F) Sensor.>
5 CHECK POOR CONTACT. Check the poor contact in ECM and front oxygen (A/F) sensor connector.	Is there poor contact in ECM or front oxygen (A/F) sensor connector?	Repair the poor contact in ECM or front oxygen (A/F) sensor connector.	Replace the front oxygen (A/F) sensor. <Ref. to FU(H4DOTC)-37, Front Oxygen (A/F) Sensor.>

D: DTC P0031 — HO2S HEATER CONTROL CIRCUIT LOW (BANK 1 SENSOR 1)

DTC DETECTING CONDITION:

- Immediately at fault recognition
- GENERAL DESCRIPTION <Ref. to GD(H4DOTC)-14, DTC P0031 — HO2S HEATER CONTROL CIRCUIT LOW (BANK 1 SENSOR 1) —, Diagnostic Trouble Code (DTC) Detecting Criteria.>

CAUTION:

After repair or replacement of faulty parts, conduct Clear Memory Mode <Ref. to EN(H4DOTC)-44, OPERATION, Clear Memory Mode.> and Inspection Mode <Ref. to EN(H4DOTC)-36, OPERATION, Inspection Mode.>.

WIRING DIAGRAM:

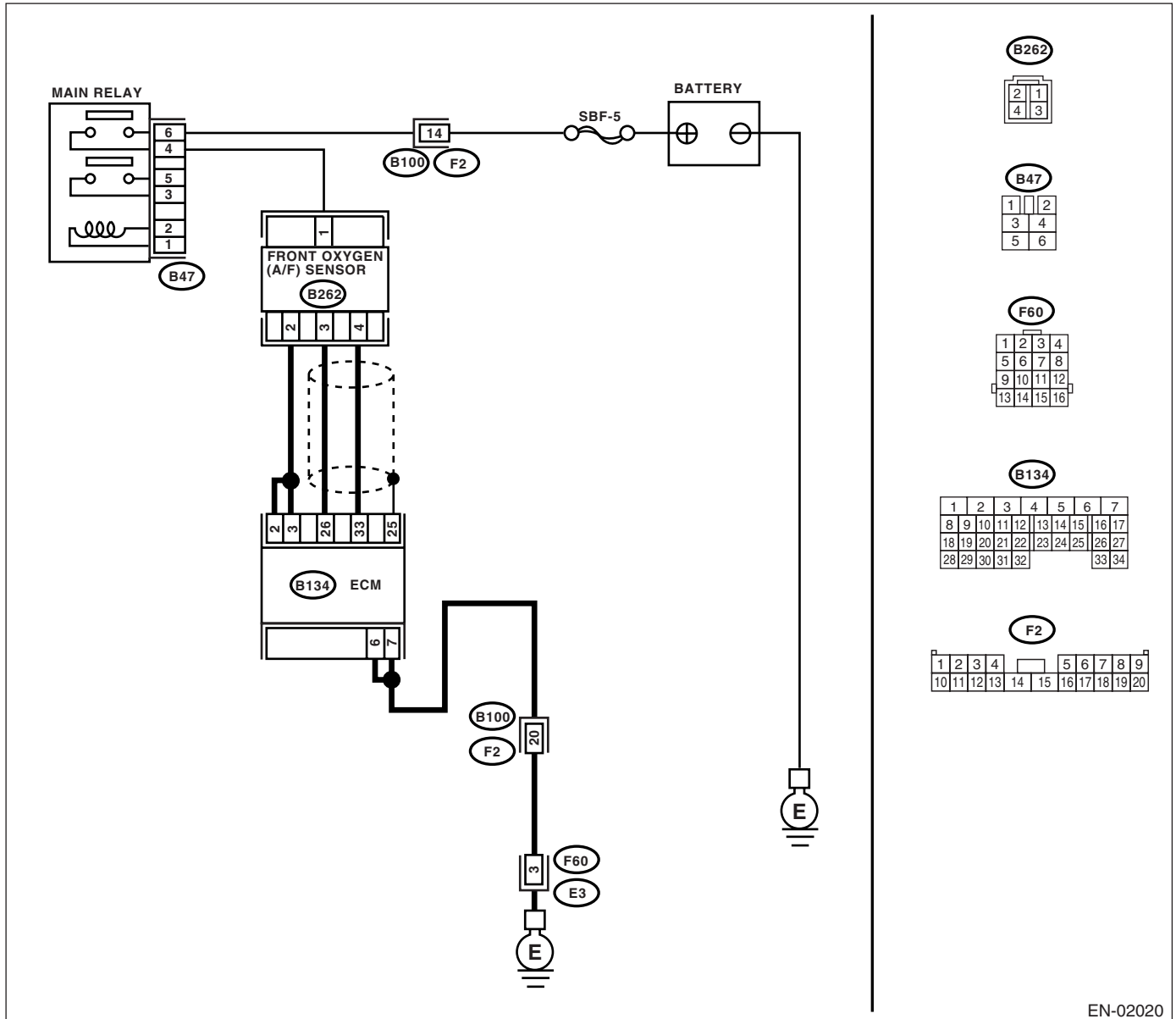

EN-02020

DIAGNOSTIC PROCEDURE WITH DIAGNOSTIC TROUBLE CODE (DTC)

ENGINE (DIAGNOSTICS)

Step	Check	Yes	No
1 CHECK POWER SUPPLY TO FRONT OXYGEN (A/F) SENSOR. 1) Turn the ignition switch to OFF. 2) Disconnect the connector from front oxygen (A/F) sensor. 3) Turn the ignition switch to ON. 4) Measure the voltage between front oxygen (A/F) sensor connector and engine ground. Connector & terminal (B262) No. 1 (+) — Engine ground (-):	Is the voltage more than 10 V?	Go to step 2.	Repair the power supply line. NOTE: In this case, repair the following: <ul style="list-style-type: none"> • Open circuit in harness between main relay and front oxygen (A/F) sensor connector • Poor contact in front oxygen (A/F) sensor connector • Poor contact in main relay connector
2 CHECK GROUND CIRCUIT OF ECM. Measure the resistance of harness between ECM connector and chassis ground. Connector & terminal (B134) No. 6 — Chassis ground: (B134) No. 7 — Chassis ground:	Is the resistance less than 5 Ω?	Go to step 3.	Repair the harness and connector. NOTE: In this case, repair the following: <ul style="list-style-type: none"> • Open circuit in harness between ECM and engine ground cable • Poor contact in ECM connector • Poor contact in coupling connector
3 CHECK CURRENT DATA. 1) Start the engine. 2) Read the data of front oxygen (A/F) sensor heater current using Subaru Select Monitor or OBD-II general scan tool. NOTE: <ul style="list-style-type: none"> • Subaru Select Monitor For detailed operation procedure, refer to the "READ CURRENT DATA FOR ENGINE". <Ref. to EN(H4DOTC)-29, Subaru Select Monitor.> <ul style="list-style-type: none"> • OBD-II scan tool For detailed operation procedures, refer to the OBD-II General Scan Tool Instruction Manual.	Is the current more than 0.2 A?	Repair the poor contact in connector. NOTE: In this case, repair the following: <ul style="list-style-type: none"> • Poor contact in front oxygen (A/F) sensor connector • Poor contact in ECM connector 	Go to step 4.
4 CHECK OUTPUT SIGNAL FROM ECM. 1) Start and idle the engine. 2) Measure the voltage between ECM connector and chassis ground. Connector & terminal (B134) No. 2 (+) — Chassis ground (-): (B134) No. 3 (+) — Chassis ground (-):	Is the voltage less than 1 V?	Go to step 6.	Go to step 5.
5 CHECK OUTPUT SIGNAL FROM ECM. Measure the voltage between ECM connector and chassis ground. Connector & terminal (B134) No. 2 (+) — Chassis ground (-): (B134) No. 3 (+) — Chassis ground (-):	Shake the ECM harness and connector, while monitoring value of voltage meter. Does the voltage change?	Repair the poor contact in ECM connector.	Go to step 6.

DIAGNOSTIC PROCEDURE WITH DIAGNOSTIC TROUBLE CODE (DTC)

ENGINE (DIAGNOSTICS)

Step	Check	Yes	No
<p>6 CHECK FRONT OXYGEN (A/F) SENSOR. 1) Turn the ignition switch to OFF. 2) Measure the resistance between front oxygen (A/F) sensor connector terminals. Terminals No. 1 — No. 2:</p>	<p>Is the resistance less than 10 Ω?</p>	<p>Repair the harness and connector. NOTE: In this case, repair the following:</p> <ul style="list-style-type: none">• Open or ground short circuit in harness between front oxygen (A/F) sensor and ECM connector• Poor contact in front oxygen (A/F) sensor connector• Poor contact in ECM connector	<p>Replace the front oxygen (A/F) sensor. <Ref. to FU(H4DOTC)-37, Front Oxygen (A/F) Sensor.></p>

DIAGNOSTIC PROCEDURE WITH DIAGNOSTIC TROUBLE CODE (DTC)

ENGINE (DIAGNOSTICS)

E: DTC P0032 — HO2S HEATER CONTROL CIRCUIT HIGH (BANK 1 SENSOR 1) —

DTC DETECTING CONDITION:

- Immediately at fault recognition
- GENERAL DESCRIPTION <Ref. to GD(H4DOTC)-16, DTC P0032 — HO2S HEATER CONTROL CIRCUIT HIGH (BANK 1 SENSOR 1) —, Diagnostic Trouble Code (DTC) Detecting Criteria.>

CAUTION:

After repair or replacement of faulty parts, conduct Clear Memory Mode <Ref. to EN(H4DOTC)-44, OPERATION, Clear Memory Mode.> and Inspection Mode <Ref. to EN(H4DOTC)-36, OPERATION, Inspection Mode.>.

WIRING DIAGRAM:

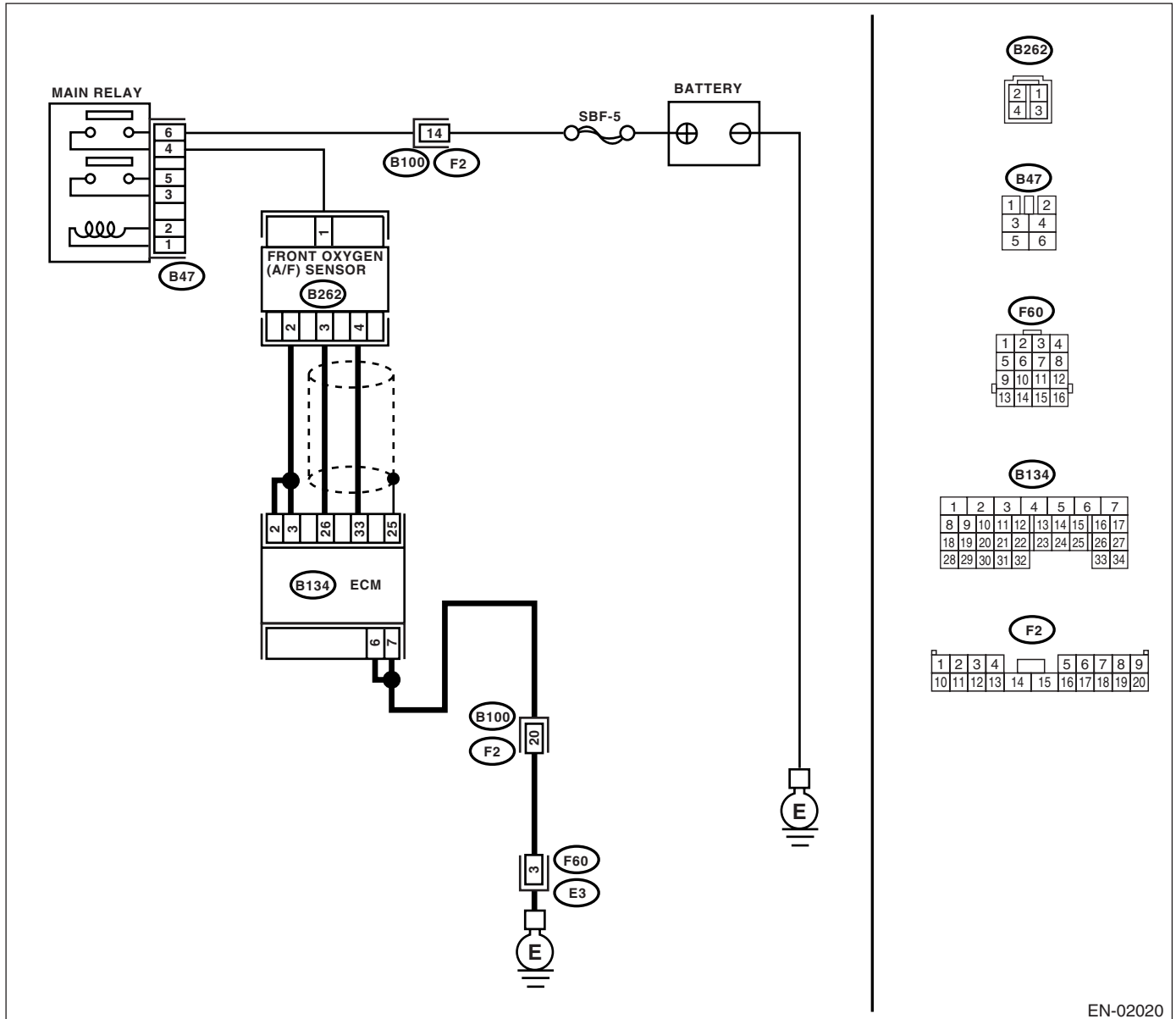

EN-02020

DIAGNOSTIC PROCEDURE WITH DIAGNOSTIC TROUBLE CODE (DTC)

ENGINE (DIAGNOSTICS)

Step	Check	Yes	No
1 CHECK OUTPUT SIGNAL FROM ECM. 1) Turn the ignition switch to ON. 2) Measure the voltage between ECM connector and chassis ground. Connector & terminal <i>(B134) No. 2 (+) — Chassis ground (-):</i> <i>(B134) No. 3 (+) — Chassis ground (-):</i>	Is the voltage more than 8 V?	Go to step 3.	Go to step 2.
2 CHECK FRONT OXYGEN (A/F) SENSOR HEATER CURRENT. 1) Turn the ignition switch to OFF. 2) Repair the battery short circuit in harness between ECM and front oxygen (A/F) sensor connector. 3) Turn the ignition switch to ON. 4) Read the data of front oxygen (A/F) sensor heater current using Subaru Select Monitor or the OBD-II general scan tool. NOTE: • Subaru Select Monitor For detailed operation procedure, refer to the "READ CURRENT DATA FOR ENGINE". <Ref. to EN(H4DOTC)-29, Subaru Select Monitor.> • OBD-II general scan tool For detailed operation procedure, refer to the OBD-II General Scan Tool Instruction Manual.	Is the current more than 2.3 A?	Replace the ECM. <Ref. to FU(H4DOTC)-42, Engine Control Module (ECM).>	END
3 CHECK OUTPUT SIGNAL FROM ECM. Measure the voltage between ECM connector and chassis ground. Connector & terminal <i>(B134) No. 2 (+) — Chassis ground (-):</i> <i>(B134) No. 3 (+) — Chassis ground (-):</i>	Shake the ECM harness and connector, while monitoring value of voltage meter. Does the voltage change?	Repair the battery short circuit in harness between ECM and front oxygen (A/F) sensor connector.	END

DIAGNOSTIC PROCEDURE WITH DIAGNOSTIC TROUBLE CODE (DTC)

ENGINE (DIAGNOSTICS)

F: DTC P0037 — HO2S HEATER CONTROL CIRCUIT LOW (BANK 1 SENSOR 2)

DTC DETECTING CONDITION:

- Immediately at fault recognition
- GENERAL DESCRIPTION <Ref. to GD(H4DOTC)-18, DTC P0037 — HO2S HEATER CONTROL CIRCUIT LOW (BANK 1 SENSOR 2) —, Diagnostic Trouble Code (DTC) Detecting Criteria.>

CAUTION:

After repair or replacement of faulty parts, conduct Clear Memory Mode <Ref. to EN(H4DOTC)-44, OPERATION, Clear Memory Mode.> and Inspection Mode <Ref. to EN(H4DOTC)-36, OPERATION, Inspection Mode.>.

WIRING DIAGRAM:

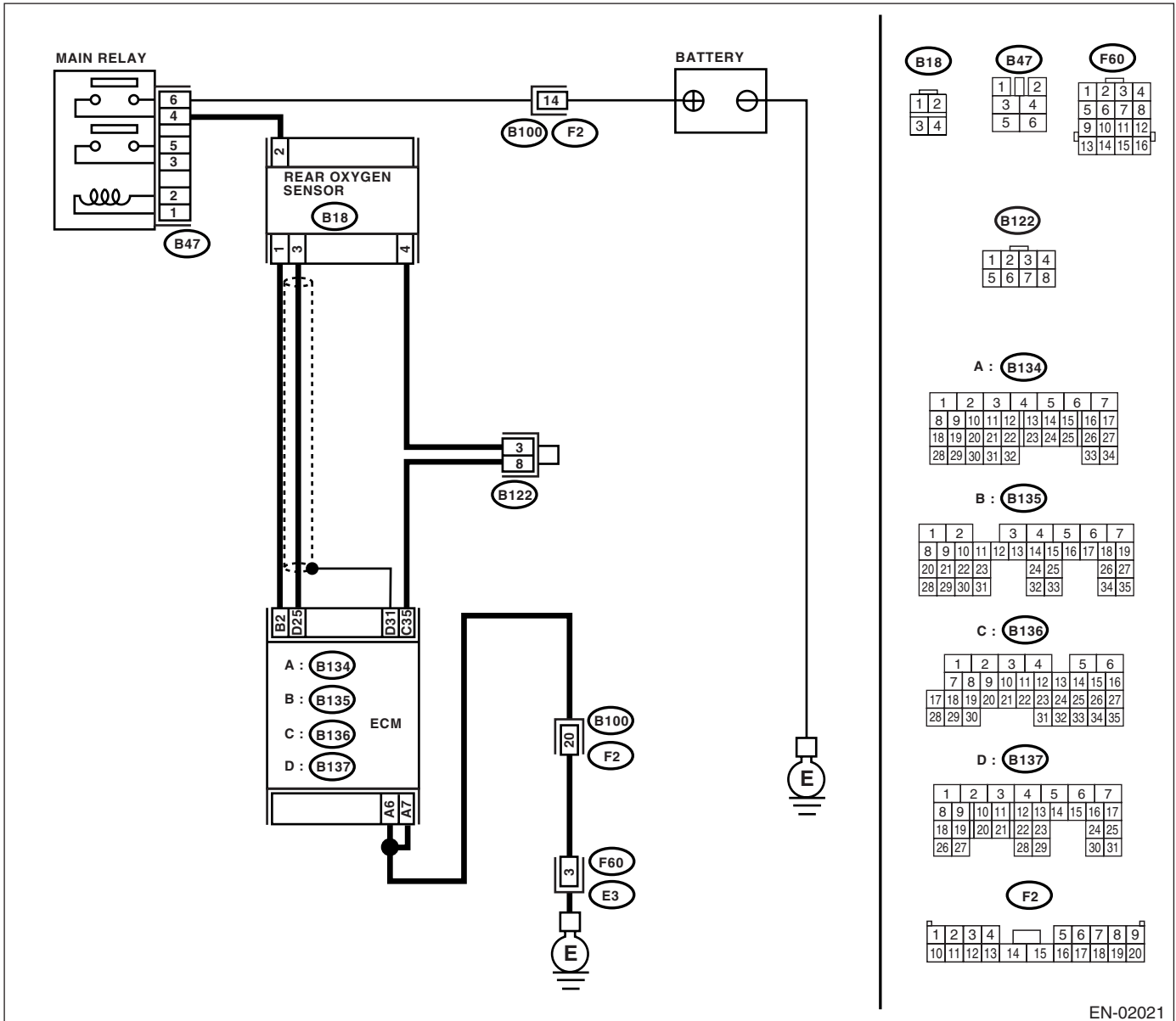

EN-02021

DIAGNOSTIC PROCEDURE WITH DIAGNOSTIC TROUBLE CODE (DTC)

ENGINE (DIAGNOSTICS)

Step	Check	Yes	No
<p>1 CHECK GROUND CIRCUIT OF ECM. 1) Turn the ignition switch to OFF. 2) Disconnect the connector from ECM. 3) Measure the resistance of harness between ECM connector and chassis ground. Connector & terminal (B134) No. 6 — Chassis ground: (B134) No. 7 — Chassis ground:</p>	<p>Is the resistance less than 5 Ω?</p>	<p>Go to step 2.</p>	<p>Repair the harness and connector. NOTE: In this case, repair the following:</p> <ul style="list-style-type: none"> • Open circuit in harness between ECM and engine ground cable • Poor contact in ECM connector • Poor contact in coupling connector
<p>2 CHECK CURRENT DATA. 1) Start the engine. 2) Read the data of rear oxygen sensor heater current using Subaru Select Monitor or OBD-II general scan tool. NOTE: • Subaru Select Monitor For detailed operation procedure, refer to the "READ CURRENT DATA FOR ENGINE". <Ref. to EN(H4DOTC)-29, Subaru Select Monitor.> • OBD-II scan tool For detailed operation procedures, refer to the OBD-II General Scan Tool Instruction Manual.</p>	<p>Is the current more than 0.2 A?</p>	<p>Repair the connector. NOTE: In this case, repair the following:</p> <ul style="list-style-type: none"> • Poor contact in rear oxygen sensor connector • Poor contact in rear oxygen sensor connecting harness connector • Poor contact in ECM connector 	<p>Go to step 3.</p>
<p>3 CHECK OUTPUT SIGNAL FROM ECM. 1) Start and idle the engine. 2) Measure the voltage between ECM connector and chassis ground. Connector & terminal (B135) No. 2 (+) — Chassis ground (-):</p>	<p>Is the voltage less than 1 V?</p>	<p>Go to step 6.</p>	<p>Go to step 4.</p>
<p>4 CHECK OUTPUT SIGNAL FROM ECM. Measure the voltage between ECM connector and chassis ground. Connector & terminal (B135) No. 2 (+) — Chassis ground (-):</p>	<p>Shake the ECM harness and connector, while monitoring value of voltage meter. Does the voltage change?</p>	<p>Repair the poor contact in ECM connector.</p>	<p>Go to step 5.</p>
<p>5 CHECK OUTPUT SIGNAL FROM ECM. 1) Turn the ignition switch to OFF. 2) Disconnect the connector from rear oxygen sensor. 3) Measure the voltage between ECM connector and chassis ground. Connector & terminal (B135) No. 2 (+) — Chassis ground (-):</p>	<p>Is the voltage less than 1 V?</p>	<p>Replace the ECM. <Ref. to FU(H4DOTC)-42, Engine Control Module (ECM).></p>	<p>Repair the battery short circuit in harness between ECM and rear oxygen sensor connector. After repair, replace the ECM. <Ref. to FU(H4DOTC)-42, Engine Control Module (ECM).></p>

DIAGNOSTIC PROCEDURE WITH DIAGNOSTIC TROUBLE CODE (DTC)

ENGINE (DIAGNOSTICS)

Step	Check	Yes	No
<p>6</p> <p>CHECK POWER SUPPLY TO REAR OXYGEN SENSOR.</p> <p>1) Turn the ignition switch to OFF. 2) Disconnect the connector from rear oxygen sensor. 3) Turn the ignition switch to ON. 4) Measure the voltage between rear oxygen sensor connector and engine ground or chassis ground.</p> <p>Connector & terminal (B18) No. 2 (+) — Chassis ground (-):</p>	<p>Is the voltage more than 10 V?</p>	<p>Go to step 7.</p>	<p>Repair the power supply line.</p> <p>NOTE: In this case, repair the following:</p> <ul style="list-style-type: none"> • Open circuit in harness between main relay and rear oxygen sensor connector • Poor contact in rear oxygen sensor connector • Poor contact in coupling connector
<p>7</p> <p>CHECK REAR OXYGEN SENSOR.</p> <p>1) Turn the ignition switch to OFF. 2) Measure the resistance between rear oxygen sensor connector terminals.</p> <p>Terminals No. 1 — No. 2:</p>	<p>Is the resistance less than 30 Ω?</p>	<p>Repair the harness and connector.</p> <p>NOTE: In this case, repair the following:</p> <ul style="list-style-type: none"> • Open circuit in harness between rear oxygen sensor and ECM connector • Poor contact in rear oxygen sensor connector • Poor contact in ECM connector • Poor contact in coupling connector 	<p>Replace the rear oxygen sensor. <Ref. to FU(H4DOTC)-39, Rear Oxygen Sensor.></p>

DIAGNOSTIC PROCEDURE WITH DIAGNOSTIC TROUBLE CODE (DTC)

ENGINE (DIAGNOSTICS)

G: DTC P0038 — HO2S HEATER CONTROL CIRCUIT HIGH (BANK 1 SENSOR 2) —

DTC DETECTING CONDITION:

- Immediately at fault recognition
- GENERAL DESCRIPTION <Ref. to GD(H4DOTC)-20, DTC P0038 — HO2S HEATER CONTROL CIRCUIT HIGH (BANK 1 SENSOR 2) —, Diagnostic Trouble Code (DTC) Detecting Criteria.>

CAUTION:

After repair or replacement of faulty parts, conduct Clear Memory Mode <Ref. to EN(H4DOTC)-44, OPERATION, Clear Memory Mode.> and Inspection Mode <Ref. to EN(H4DOTC)-36, OPERATION, Inspection Mode.>.

WIRING DIAGRAM:

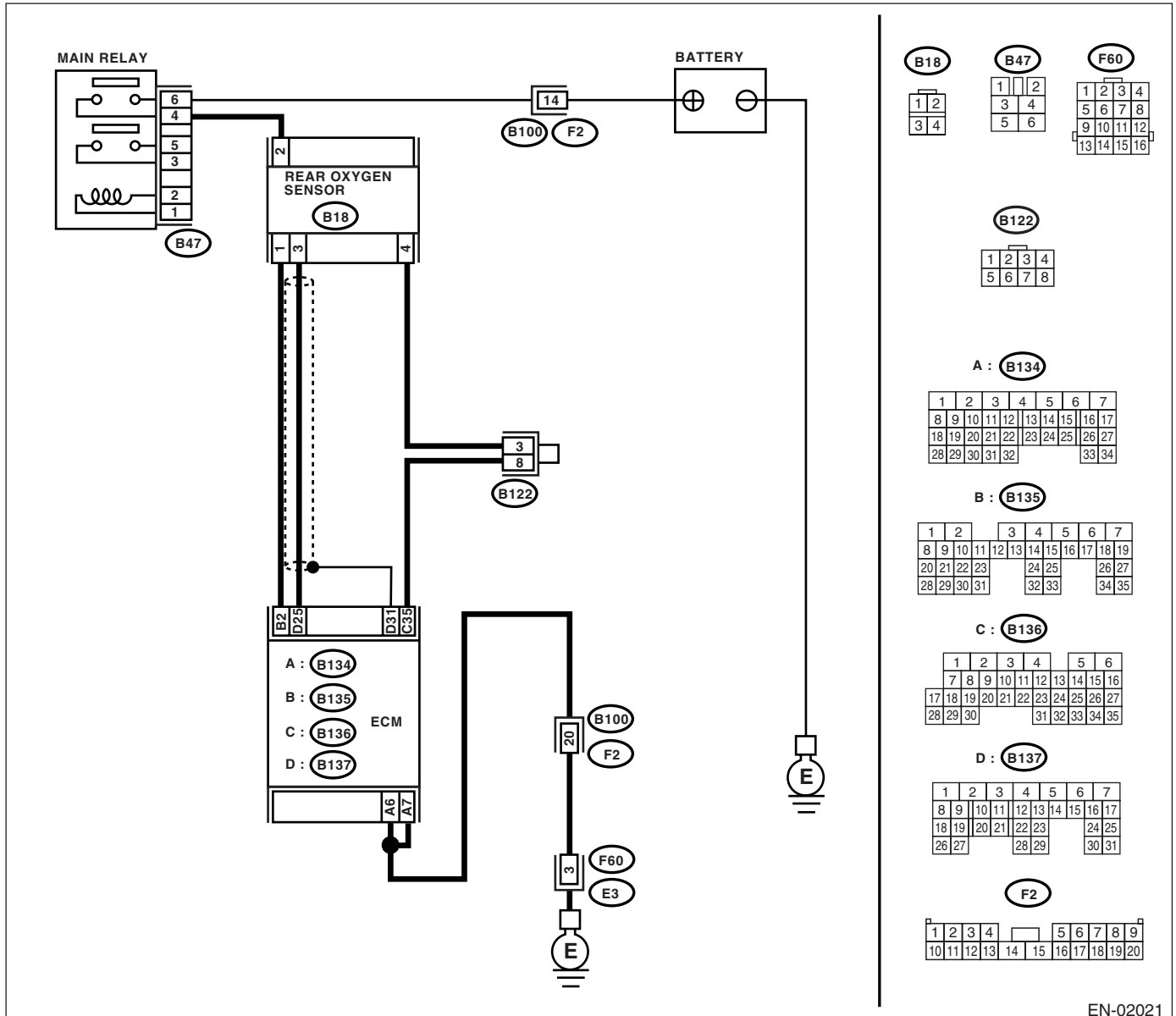

EN-02021

DIAGNOSTIC PROCEDURE WITH DIAGNOSTIC TROUBLE CODE (DTC)

ENGINE (DIAGNOSTICS)

Step	Check	Yes	No
1 CHECK INPUT SIGNAL FOR ECM. 1) Turn the ignition switch to OFF. 2) Measure the voltage between ECM connector and chassis ground. Connector & terminal (B135) No. 2 (+) — Chassis ground (-):	Is the voltage more than 8 V?	Go to step 2.	Go to step 3.
2 CHECK CURRENT DATA. 1) Repair the battery short circuit in harness between ECM and rear oxygen sensor connector. 2) Turn the ignition switch to ON. 3) Read the data of rear oxygen sensor heater current using Subaru Select Monitor or the OBD-II general scan tool. NOTE: <ul style="list-style-type: none"> • Subaru Select Monitor For detailed operation procedure, refer to the "READ CURRENT DATA FOR ENGINE". <Ref. to EN(H4DOTC)-29, Subaru Select Monitor.> <ul style="list-style-type: none"> • OBD-II general scan tool For detailed operation procedure, refer to the OBD-II General Scan Tool Instruction Manual.	Is the current more than 7 A?	Replace the ECM. <Ref. to FU(H4DOTC)-42, Engine Control Module (ECM).>	END
3 CHECK POOR CONTACT. Check poor contact in ECM connector.	Is there poor contact in ECM connector?	Repair the poor contact in ECM connector.	END

H: DTC P0068 — MANIFOLD ABSOLUTE PRESSURE/BAROMETRIC PRESSURE CIRCUIT RANGE/PERFORMANCE —

DTC DETECTING CONDITION:

- Two consecutive driving cycles with fault
- GENERAL DESCRIPTION <Ref. to GD(H4DOTC)-22, DTC P0068 — MANIFOLD PRESSURE SENSOR RANGE/PERFORMANCE —, Diagnostic Trouble Code (DTC) Detecting Criteria.>

TROUBLE SYMPTOM:

Failure of engine to start

CAUTION:

After repair or replacement of faulty parts, conduct Clear Memory Mode <Ref. to EN(H4DOTC)-44, OPERATION, Clear Memory Mode.> and Inspection Mode <Ref. to EN(H4DOTC)-36, OPERATION, Inspection Mode.>.

WIRING DIAGRAM:

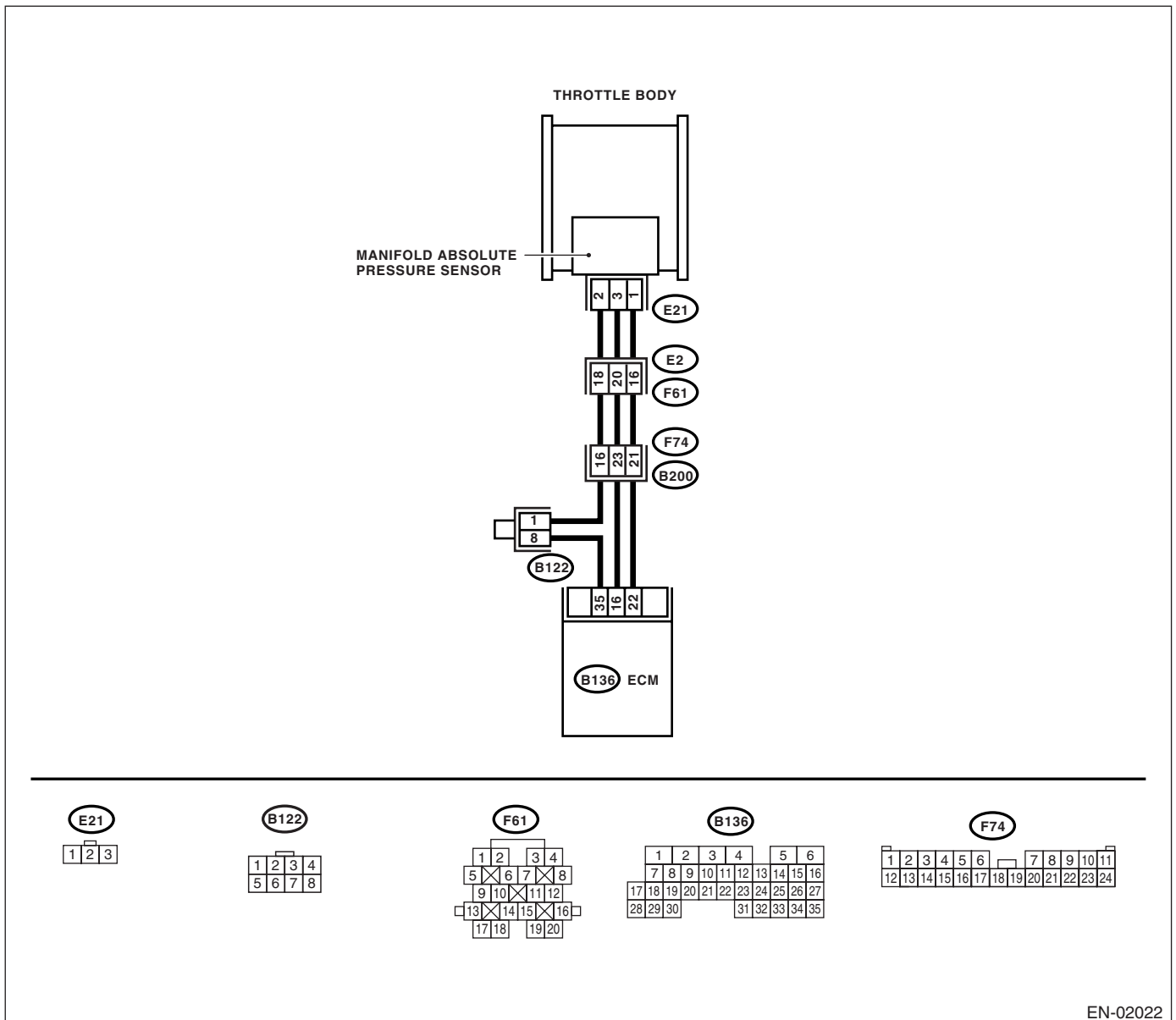

EN-02022

DIAGNOSTIC PROCEDURE WITH DIAGNOSTIC TROUBLE CODE (DTC)

ENGINE (DIAGNOSTICS)

Step	Check	Yes	No
1 CHECK IDLE SWITCH SIGNAL. 1) Turn the ignition switch to ON. 2) Operate the LED operation mode for engine using Subaru Select Monitor. NOTE: • Subaru Select Monitor For detailed operation procedure, refer to the "LED OPERATION MODE FOR ENGINE". <Ref. to EN(H4DOTC)-29, Subaru Select Monitor.>	Does the LED of {Idle Switch Signal} come on?	Go to step 2.	Check the throttle position sensor circuit. <Ref. to EN(H4DOTC)-374, DTC P2135 — THROTTLE/PEDAL POSITION SENSOR/SWITCH "A"/"B" VOLTAGE RATIO-NALITY —, Diagnostic Procedure with Diagnostic Trouble Code (DTC).> NOTE: In this case, it is not necessary to inspect DTC P0106.
2 CHECK ANY OTHER DTC ON DISPLAY.	Is any other DTC displayed?	Inspect the relevant DTC. "List of Diagnostic Trouble Code (DTC)". <Ref. to EN(H4DOTC)-68, List of Diagnostic Trouble Code (DTC).> NOTE: In this case, it is not necessary to inspect DTC P0106.	Go to step 3.
3 CHECK CONDITION OF MANIFOLD ABSOLUTE PRESSURE SENSOR.	Is the manifold absolute pressure sensor installation bolt tightened securely?	Go to step 4.	Tighten the manifold absolute pressure sensor installation bolt securely.
4 CHECK CONDITION OF THROTTLE BODY.	Is the throttle body installation bolt tightened securely?	Replace the manifold absolute pressure sensor. <Ref. to FU(H4DOTC)-31, Manifold Absolute Pressure Sensor.>	Tighten the throttle body installation bolt securely.

I: DTC P0101 — MASS OR VOLUME AIR FLOW CIRCUIT RANGE/PERFORMANCE —

DTC DETECTING CONDITION:

- Two consecutive driving cycles with fault
- GENERAL DESCRIPTION <Ref. to GD(H4DOTC)-24, DTC P0101 — MASS OR VOLUME AIR FLOW CIRCUIT RANGE/PERFORMANCE —, Diagnostic Trouble Code (DTC) Detecting Criteria.>

TROUBLE SYMPTOM:

- Erroneous idling
- Engine stalls.
- Poor driving performance

CAUTION:

After repair or replacement of faulty parts, conduct Clear Memory Mode <Ref. to EN(H4DOTC)-44, OPERATION, Clear Memory Mode.> and Inspection Mode <Ref. to EN(H4DOTC)-36, OPERATION, Inspection Mode.>.

WIRING DIAGRAM:

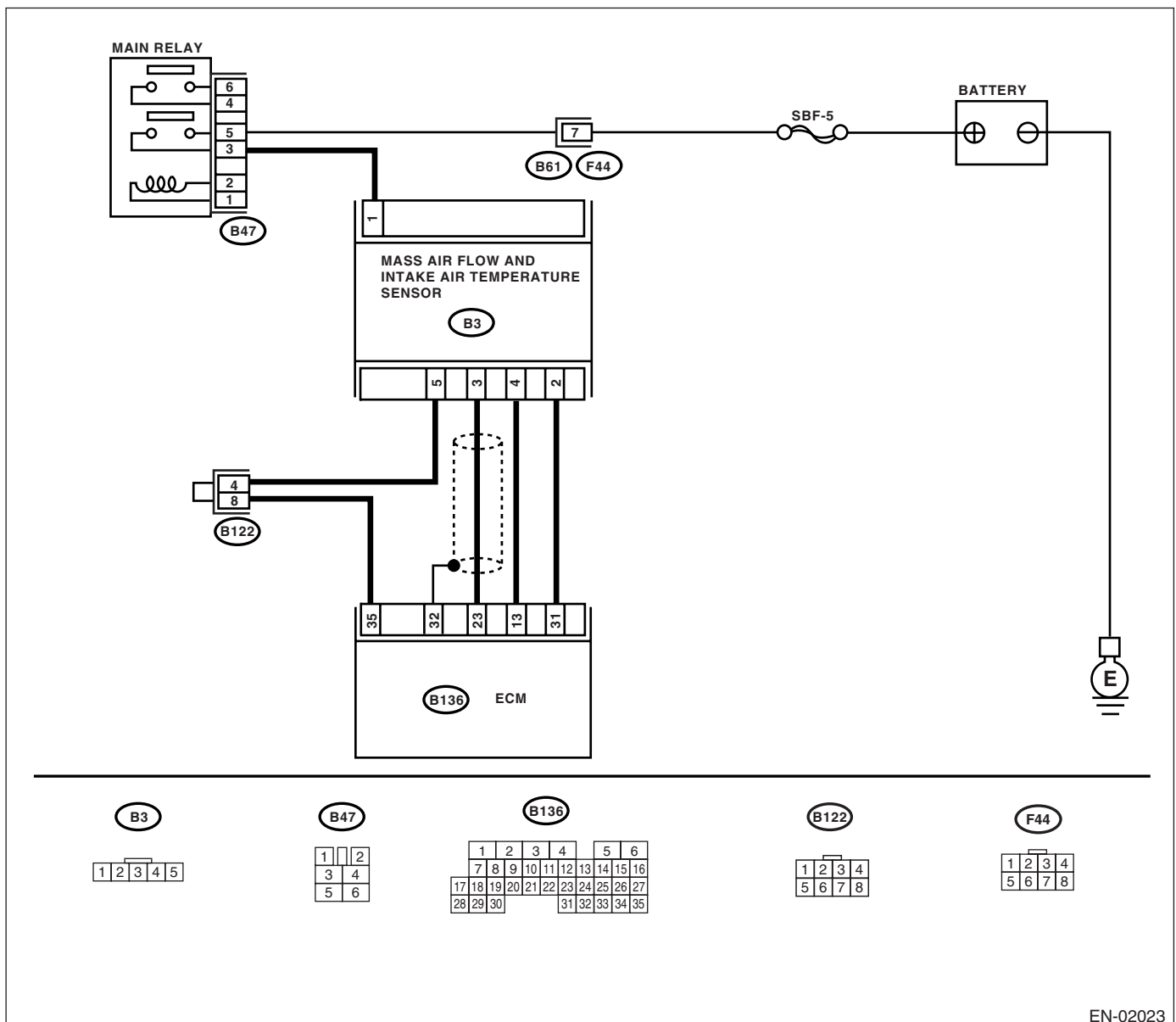

DIAGNOSTIC PROCEDURE WITH DIAGNOSTIC TROUBLE CODE (DTC)

ENGINE (DIAGNOSTICS)

Step	Check	Yes	No
1 CHECK ANY OTHER DTC ON DISPLAY.	Is any other DTC displayed?	Inspect the relevant DTC using "List of Diagnostic Trouble Code (DTC)". <Ref. to EN(H4DOTC)-68, List of Diagnostic Trouble Code (DTC).> NOTE: In this case, it is not necessary to inspect DTC P0101.	Replace the mass air flow and intake air temperature sensor. <Ref. to FU(H4DOTC)-30, Mass Air Flow and Intake Air Temperature Sensor.>

DIAGNOSTIC PROCEDURE WITH DIAGNOSTIC TROUBLE CODE (DTC)

ENGINE (DIAGNOSTICS)

J: DTC P0102 — MASS OR VOLUME AIR FLOW CIRCUIT LOW INPUT —

DTC DETECTING CONDITION:

- Immediately at fault recognition
- GENERAL DESCRIPTION <Ref. to GD(H4DOTC)-27, DTC P0102 — MASS OR VOLUME AIR FLOW CIRCUIT LOW INPUT —, Diagnostic Trouble Code (DTC) Detecting Criteria.>

TROUBLE SYMPTOM:

- Erroneous idling
- Engine stalls.
- Poor driving performance

CAUTION:

After repair or replacement of faulty parts, conduct Clear Memory Mode <Ref. to EN(H4DOTC)-44, OPERATION, Clear Memory Mode.> and Inspection Mode <Ref. to EN(H4DOTC)-36, OPERATION, Inspection Mode.>.

WIRING DIAGRAM:

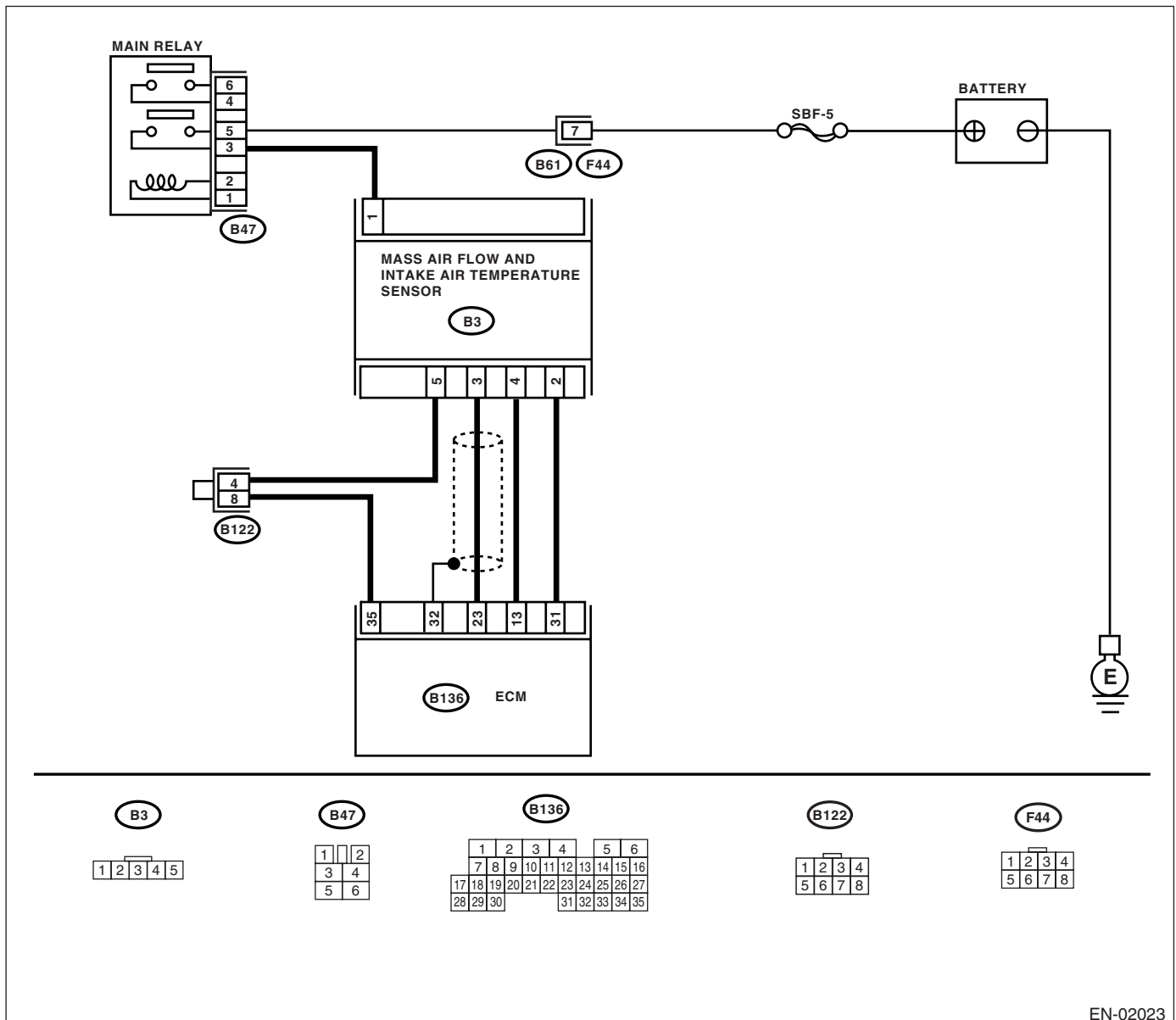

EN-02023

DIAGNOSTIC PROCEDURE WITH DIAGNOSTIC TROUBLE CODE (DTC)

ENGINE (DIAGNOSTICS)

Step	Check	Yes	No
<p>1 CONNECT SUBARU SELECT MONITOR OR THE OBD-II GENERAL SCAN TOOL, AND READ DATA.</p> <p>1) Turn the ignition switch to OFF. 2) Connect the Subaru Select Monitor or OBD-II general scan tool to data link connector. 3) Turn the ignition switch to ON and Subaru Select Monitor or the OBD-II general scan tool switch to ON. 4) Start the engine. 5) Read the mass air flow sensor voltage using Subaru Select Monitor or OBD-II general scan tool.</p> <p>NOTE:</p> <ul style="list-style-type: none"> Subaru Select Monitor <p>For detailed operation procedure, refer to the "READ CURRENT DATA FOR ENGINE". <Ref. to EN(H4DOTC)-29, Subaru Select Monitor.></p> <ul style="list-style-type: none"> OBD-II general scan tool <p>For detailed operation procedures, refer to the OBD-II General Scan Tool Instruction Manual.</p>	Is the voltage 0.2 — 4.7 V?	Even if malfunction indicator light lights up, the circuit has returned to a normal condition at this time. A temporary poor contact of the connector or harness may be the cause. Repair the harness or connector in the mass air flow sensor.	Go to step 2.
<p>2 CHECK INPUT SIGNAL FOR ECM.</p> <p>Measure the voltage between ECM connector and chassis ground while engine is idling.</p> <p>Connector & terminal (B136) No. 23 (+) — Chassis ground (-):</p>	Is the voltage more than 0.2 V?	Go to step 4.	Go to step 3.
<p>3 CHECK INPUT SIGNAL FOR ECM (USING SUBARU SELECT MONITOR).</p> <p>Measure the voltage between ECM connector and chassis ground while engine is idling.</p>	Shake the ECM harness and connector, while monitoring value of Subaru Select Monitor. Does the voltage change?	Repair the poor contact in ECM connector.	Contact your SOA Service Center. NOTE: Inspection by DTM is required, because probable cause is deterioration of multiple parts.
<p>4 CHECK POWER SUPPLY TO MASS AIR FLOW SENSOR.</p> <p>1) Turn the ignition switch to OFF. 2) Disconnect the connector from mass air flow sensor. 3) Turn the ignition switch to ON. 4) Measure the voltage between mass air flow sensor connector and chassis ground.</p> <p>Connector & terminal (B3) No. 1 (+) — Chassis ground (-):</p>	Is the voltage more than 5 V?	Go to step 5.	Repair the open circuit between mass air flow sensor and main relay.

DIAGNOSTIC PROCEDURE WITH DIAGNOSTIC TROUBLE CODE (DTC)

ENGINE (DIAGNOSTICS)

Step	Check	Yes	No
5 CHECK HARNESS BETWEEN ECM AND MASS AIR FLOW SENSOR CONNECTOR. 1) Turn the ignition switch to OFF. 2) Disconnect the connector from ECM. 3) Measure the resistance of harness between ECM and mass air flow sensor connector. <i>Connector & terminal</i> (B136) No. 23 — (B3) No. 3: (B136) No. 31 — (B3) No. 2: (B136) No. 35 — (B3) No. 5:	Is the resistance less than 1 Ω ?	Go to step 6.	Repair the open circuit between ECM and mass air flow sensor connector.
6 CHECK HARNESS BETWEEN ECM AND MASS AIR FLOW SENSOR CONNECTOR Measure the resistance of harness between ECM and chassis ground. <i>Connector & terminal</i> (B136) No. 23 — Chassis ground: (B136) No. 31 — Chassis ground: (B136) No. 35 — Chassis ground:	Is the resistance more than 1 M Ω ?	Go to step 7.	Repair the ground short circuit between ECM and mass air flow sensor connector.
7 CHECK POOR CONTACT Check poor contact in mass air flow sensor connector.	Is there poor contact in mass air flow sensor connector?	Repair the poor contact in mass air flow sensor connector.	Replace the mass air flow and intake air temperature sensor. <Ref. to FU(H4DOTC)-30, Mass Air Flow and Intake Air Temperature Sensor.>

DIAGNOSTIC PROCEDURE WITH DIAGNOSTIC TROUBLE CODE (DTC)

ENGINE (DIAGNOSTICS)

K: DTC P0103 — MASS OR VOLUME AIR FLOW CIRCUIT HIGH INPUT — DTC DETECTING CONDITION:

- Immediately at fault recognition
- GENERAL DESCRIPTION <Ref. to GD(H4DOTC)-29, DTC P0103 — MASS OR VOLUME AIR FLOW CIRCUIT HIGH INPUT —, Diagnostic Trouble Code (DTC) Detecting Criteria.>

TROUBLE SYMPTOM:

- Erroneous idling
- Engine stalls.
- Poor driving performance

CAUTION:

After repair or replacement of faulty parts, conduct Clear Memory Mode <Ref. to EN(H4DOTC)-44, OPERATION, Clear Memory Mode.> and Inspection Mode <Ref. to EN(H4DOTC)-36, OPERATION, Inspection Mode.>.

WIRING DIAGRAM:

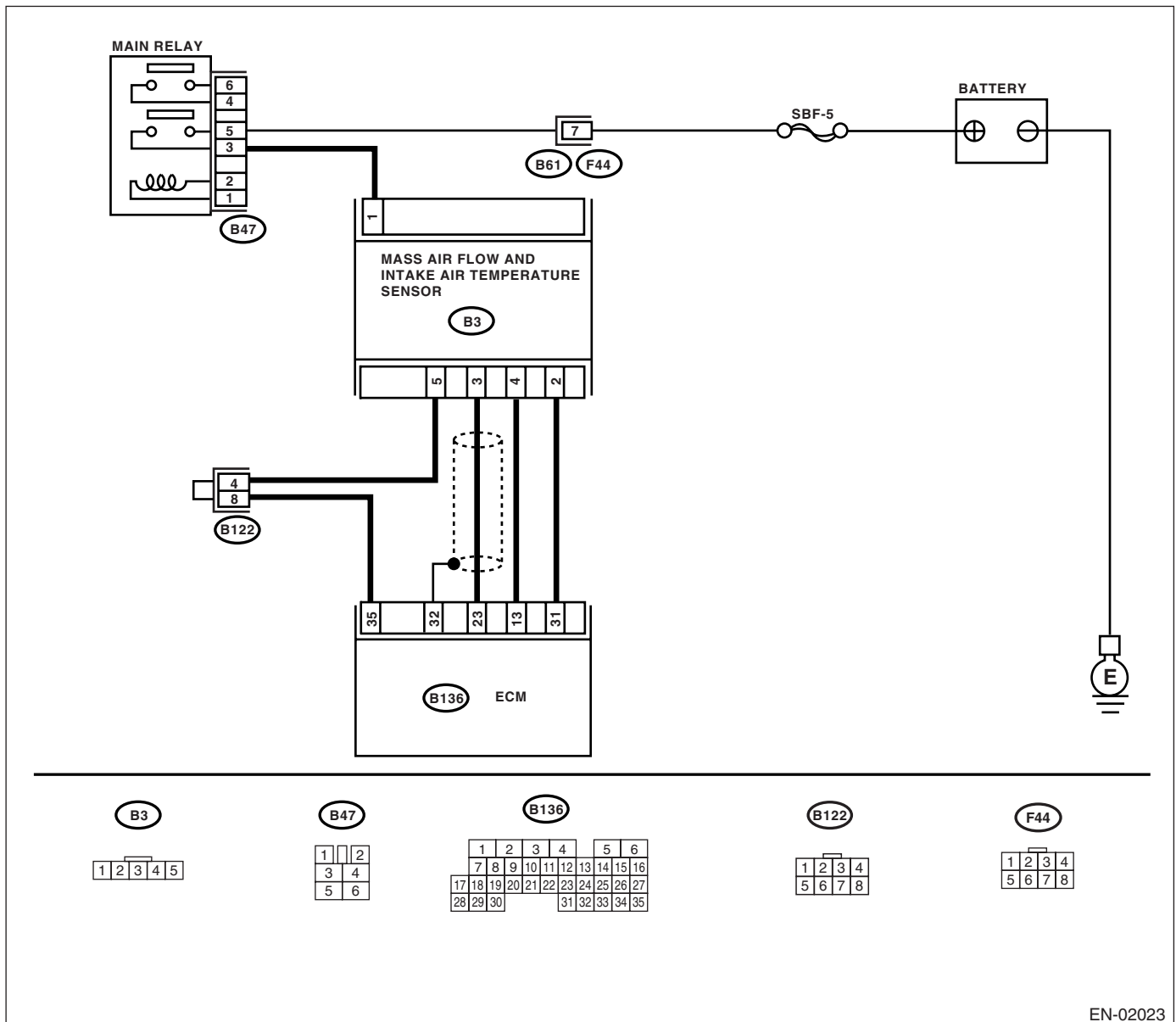

EN-02023

DIAGNOSTIC PROCEDURE WITH DIAGNOSTIC TROUBLE CODE (DTC)

ENGINE (DIAGNOSTICS)

Step	Check	Yes	No
<p>1</p> <p>CONNECT SUBARU SELECT MONITOR OR THE OBD-II GENERAL SCAN TOOL, AND READ DATA.</p> <p>1) Turn the ignition switch to OFF.</p> <p>2) Connect the Subaru Select Monitor or OBD-II general scan tool to data link connector.</p> <p>3) Turn the ignition switch to ON and Subaru Select Monitor or OBD-II general scan tool switch to ON.</p> <p>4) Start the engine.</p> <p>5) Read the mass air flow sensor voltage using Subaru Select Monitor or OBD-II general scan tool.</p> <p>NOTE:</p> <ul style="list-style-type: none"> • Subaru Select Monitor <p>For detailed operation procedure, refer to the "READ CURRENT DATA FOR ENGINE". <Ref. to EN(H4DOTC)-29, Subaru Select Monitor.></p> <ul style="list-style-type: none"> • OBD-II general scan tool <p>For detailed operation procedures, refer to the OBD-II General Scan Tool Instruction Manual.</p>	<p>Is the voltage 0.2 — 4.7 V?</p>	<p>Even if malfunction indicator light lights up, the circuit has returned to a normal condition at this time.</p>	<p>Go to step 2.</p>
<p>2</p> <p>CHECK HARNESS BETWEEN ECM AND MASS AIR FLOW SENSOR CONNECTOR.</p> <p>1) Turn the ignition switch to OFF.</p> <p>2) Disconnect the connector from mass air flow sensor.</p> <p>3) Turn the ignition switch to ON.</p> <p>4) Measure the voltage between mass air flow sensor connector and chassis ground.</p> <p>Connector & terminal (B3) No. 3 (+) — Chassis ground (-):</p>	<p>Is the voltage more than 5 V?</p>	<p>Repair the battery short of harness between mass air flow sensor connector and ECM connector.</p>	<p>Go to step 3.</p>
<p>3</p> <p>CHECK HARNESS BETWEEN ECM AND MASS AIR FLOW SENSOR CONNECTOR.</p> <p>1) Turn the ignition switch to OFF.</p> <p>2) Disconnect the connector from ECM.</p> <p>3) Measure the resistance between ECM connector and mass air flow sensor connector.</p> <p>Connector & terminal (B3) No. 2 — (B136) No. 31:</p>	<p>Is the resistance less than 1 Ω?</p>	<p>Replace the mass air flow sensor. <Ref. to FU(H4DOTC)-30, Mass Air Flow and Intake Air Temperature Sensor.></p>	<p>Repair the open harness between mass air flow sensor connector and ECM connector.</p>

DIAGNOSTIC PROCEDURE WITH DIAGNOSTIC TROUBLE CODE (DTC)

ENGINE (DIAGNOSTICS)

L: DTC P0107 — MANIFOLD ABSOLUTE PRESSURE/BAROMETRIC PRESSURE CIRCUIT LOW INPUT —

DTC DETECTING CONDITION:

- Immediately at fault recognition
- GENERAL DESCRIPTION <Ref. to GD(H4DOTC)-31, DTC P0107 — MANIFOLD ABSOLUTE PRESSURE/BAROMETRIC PRESSURE CIRCUIT LOW INPUT —, Diagnostic Trouble Code (DTC) Detecting Criteria.>

CAUTION:

After repair or replacement of faulty parts, conduct Clear Memory Mode <Ref. to EN(H4DOTC)-44, OPERATION, Clear Memory Mode.> and Inspection Mode <Ref. to EN(H4DOTC)-36, OPERATION, Inspection Mode.>.

WIRING DIAGRAM:

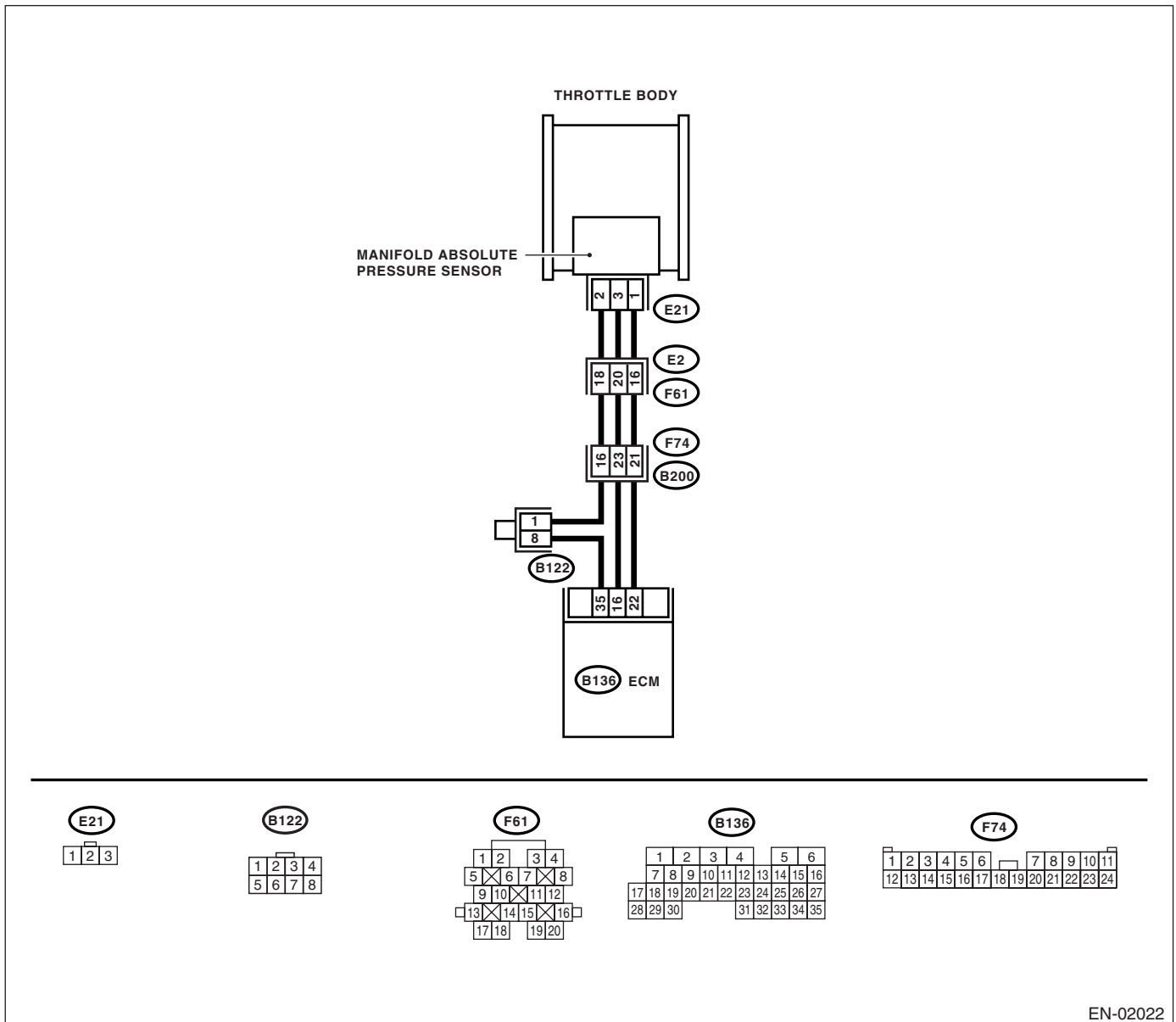

EN-02022

DIAGNOSTIC PROCEDURE WITH DIAGNOSTIC TROUBLE CODE (DTC)

ENGINE (DIAGNOSTICS)

Step	Check	Yes	No
<p>1</p> <p>CHECK INPUT SIGNAL FOR ECM. Measure the voltage between ECM connector and chassis ground. <i>Connector & terminal</i> <i>(B136) No. 16 (+) — Chassis ground (-):</i></p>	Is the voltage more than 4.5 V?	Go to step 3.	Go to step 2.
<p>2</p> <p>CHECK INPUT SIGNAL FOR ECM. Measure the voltage between ECM connector and chassis ground. <i>Connector & terminal</i> <i>(B136) No. 16 (+) — Chassis ground (-):</i></p>	Shake the ECM harness and connector, while monitoring value of voltage meter. Does the voltage change?	Repair the poor contact in ECM connector.	Contact your SOA Service Center. NOTE: Inspection by DTM is required, because probable cause is deterioration of multiple parts.
<p>3</p> <p>CHECK INPUT SIGNAL FOR ECM. Measure the voltage between ECM and chassis ground. <i>Connector & terminal</i> <i>(B136) No. 22 (+) — Chassis ground (-):</i></p>	Is the voltage less than 0.7 V?	Go to step 4.	Contact your SOA Service Center. NOTE: Inspection by DTM is required, because probable cause is deterioration of multiple parts.
<p>4</p> <p>CHECK HARNESS BETWEEN ECM AND MANIFOLD ABSOLUTE PRESSURE SENSOR CONNECTOR. 1) Turn the ignition switch to OFF. 2) Disconnect the connector from manifold absolute pressure sensor. 3) Turn the ignition switch to ON. 4) Measure the voltage between manifold absolute pressure sensor connector and engine ground. <i>Connector & terminal</i> <i>(E21) No. 3 (+) — Engine ground (-):</i></p>	Is the voltage more than 4.5 V?	Go to step 5.	Repair the open circuit in harness between ECM and manifold absolute pressure sensor connector.
<p>5</p> <p>CHECK HARNESS BETWEEN ECM AND MANIFOLD ABSOLUTE PRESSURE SENSOR CONNECTOR. 1) Turn the ignition switch to OFF. 2) Disconnect the connector from ECM. 3) Measure the resistance of harness between ECM and manifold absolute pressure sensor connector. <i>Connector & terminal</i> <i>(B136) No. 35 — (E21) No. 2:</i></p>	Is the resistance less than 1 Ω ?	Go to step 6.	Repair the open circuit in harness between ECM and manifold absolute pressure sensor connector.
<p>6</p> <p>CHECK HARNESS BETWEEN ECM AND MANIFOLD ABSOLUTE PRESSURE SENSOR CONNECTOR. Measure the resistance of harness between manifold absolute pressure sensor connector and engine ground. <i>Connector & terminal</i> <i>(E21) No. 1 — Engine ground:</i></p>	Is the resistance more than 1 M Ω ?	Go to step 7.	Repair the ground short circuit in harness between ECM and manifold absolute pressure sensor connector.
<p>7</p> <p>CHECK POOR CONTACT. Check poor contact in manifold absolute pressure sensor connector.</p>	Is there poor contact in manifold absolute pressure sensor connector?	Repair the poor contact in manifold absolute pressure sensor connector.	Replace the manifold absolute pressure sensor. <Ref. to FU(H4DOTC)-31, Manifold Absolute Pressure Sensor.>

DIAGNOSTIC PROCEDURE WITH DIAGNOSTIC TROUBLE CODE (DTC)

ENGINE (DIAGNOSTICS)

M: DTC P0108 — MANIFOLD ABSOLUTE PRESSURE/BAROMETRIC PRESSURE CIRCUIT HIGH INPUT —

DTC DETECTING CONDITION:

- Immediately at fault recognition
- GENERAL DESCRIPTION <Ref. to GD(H4DOTC)-33, DTC P0108 — MANIFOLD ABSOLUTE PRESSURE/BAROMETRIC PRESSURE CIRCUIT HIGH INPUT —, Diagnostic Trouble Code (DTC) Detecting Criteria.>

CAUTION:

After repair or replacement of faulty parts, conduct Clear Memory Mode <Ref. to EN(H4DOTC)-44, OPERATION, Clear Memory Mode.> and Inspection Mode <Ref. to EN(H4DOTC)-36, OPERATION, Inspection Mode.>.

WIRING DIAGRAM:

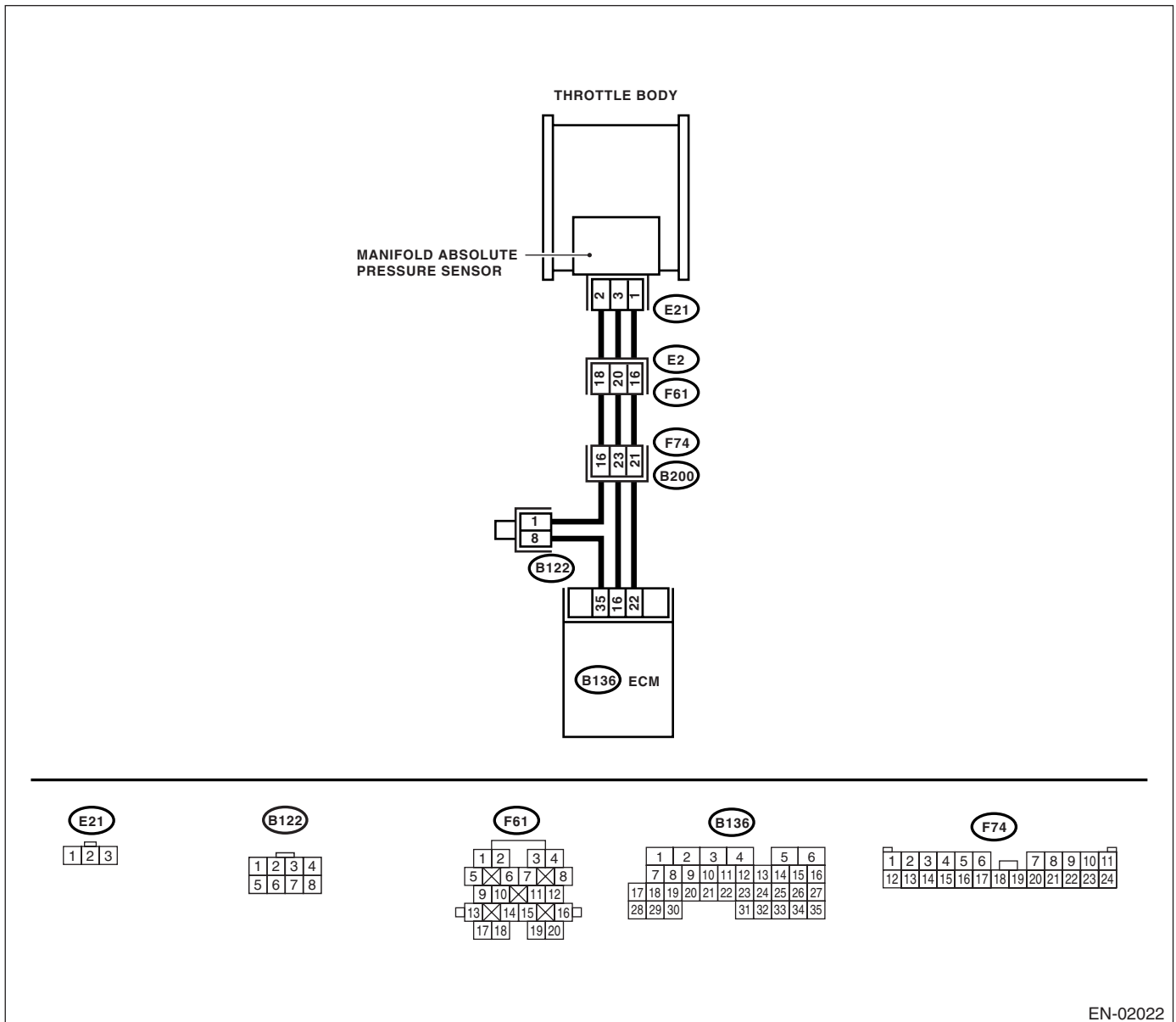

EN-02022

DIAGNOSTIC PROCEDURE WITH DIAGNOSTIC TROUBLE CODE (DTC)

ENGINE (DIAGNOSTICS)

Step	Check	Yes	No
<p>1</p> <p>CHECK INPUT SIGNAL FOR ECM. Measure the voltage between ECM connector and chassis ground. <i>Connector & terminal</i> <i>(B136) No. 16 (+) — Chassis ground (-):</i></p>	Is the voltage more than 4.5 V?	Go to step 3.	Go to step 2.
<p>2</p> <p>CHECK INPUT SIGNAL FOR ECM. Measure the voltage between ECM connector and chassis ground. <i>Connector & terminal</i> <i>(B136) No. 16 (+) — Chassis ground (-):</i></p>	Shake the ECM harness and connector, while monitoring value of voltage meter. Does the voltage change?	Repair the poor contact in ECM connector.	Contact your SOA Service Center. NOTE: Inspection by DTM is required, because probable cause is deterioration of multiple parts.
<p>3</p> <p>CHECK INPUT SIGNAL FOR ECM. Measure the voltage between ECM connector and chassis ground. <i>Connector & terminal</i> <i>(B136) No. 22 (+) — Chassis ground (-):</i></p>	Is the voltage more than 4.5 V?	Go to step 4.	Contact your SOA Service Center. NOTE: Inspection by DTM is required, because probable cause is deterioration of multiple parts.
<p>4</p> <p>CHECK HARNESS BETWEEN ECM AND MANIFOLD ABSOLUTE PRESSURE SENSOR CONNECTOR. 1) Turn the ignition switch to OFF. 2) Disconnect the connector from manifold absolute pressure sensor. 3) Turn the ignition switch to ON. 4) Measure the voltage between manifold absolute pressure sensor connector and engine ground. <i>Connector & terminal</i> <i>(E21) No. 3 (+) — Engine ground (-):</i></p>	Is the voltage more than 4.5 V?	Go to step 5.	Repair the open circuit in harness between ECM and manifold absolute pressure sensor connector.
<p>5</p> <p>CHECK HARNESS BETWEEN ECM AND MANIFOLD ABSOLUTE PRESSURE SENSOR CONNECTOR. 1) Turn the ignition switch to OFF. 2) Disconnect the connector from ECM. 3) Measure the resistance of harness between ECM and manifold absolute pressure sensor connector. <i>Connector & terminal</i> <i>(B136) No. 22 — (E21) No. 1:</i></p>	Is the resistance less than 1 Ω ?	Go to step 6.	Repair the open circuit in harness between ECM and manifold absolute pressure sensor connector.
<p>6</p> <p>CHECK HARNESS BETWEEN ECM AND MANIFOLD ABSOLUTE PRESSURE SENSOR CONNECTOR. Measure the resistance of harness between ECM and manifold absolute pressure sensor connector. <i>Connector & terminal</i> <i>(B136) No. 35 — (E21) No. 2:</i></p>	Is the resistance less than 1 Ω ?	Go to step 7.	Repair the open circuit in harness between ECM and manifold absolute pressure sensor connector.
<p>7</p> <p>CHECK POOR CONTACT. Check poor contact in manifold absolute pressure sensor connector.</p>	Is there poor contact in manifold absolute pressure sensor connector?	Repair the poor contact in manifold absolute pressure sensor connector.	Replace the manifold absolute pressure sensor. <Ref. to FU(H4DOTC)-31, Manifold Absolute Pressure Sensor.>

DIAGNOSTIC PROCEDURE WITH DIAGNOSTIC TROUBLE CODE (DTC)

ENGINE (DIAGNOSTICS)

N: DTC P0111 — INTAKE AIR TEMPERATURE CIRCUIT RANGE/PERFORMANCE —

DTC DETECTING CONDITION:

- Two consecutive driving cycles with fault
- GENERAL DESCRIPTION <Ref. to GD(H4DOTC)-35, DTC P0111 — INTAKE AIR TEMPERATURE CIRCUIT RANGE/PERFORMANCE —, Diagnostic Trouble Code (DTC) Detecting Criteria.>

TROUBLE SYMPTOM:

- Erroneous idling
- Poor driving performance

CAUTION:

After repair or replacement of faulty parts, conduct Clear Memory Mode <Ref. to EN(H4DOTC)-44, OPERATION, Clear Memory Mode.> and Inspection Mode <Ref. to EN(H4DOTC)-36, OPERATION, Inspection Mode.>.

WIRING DIAGRAM:

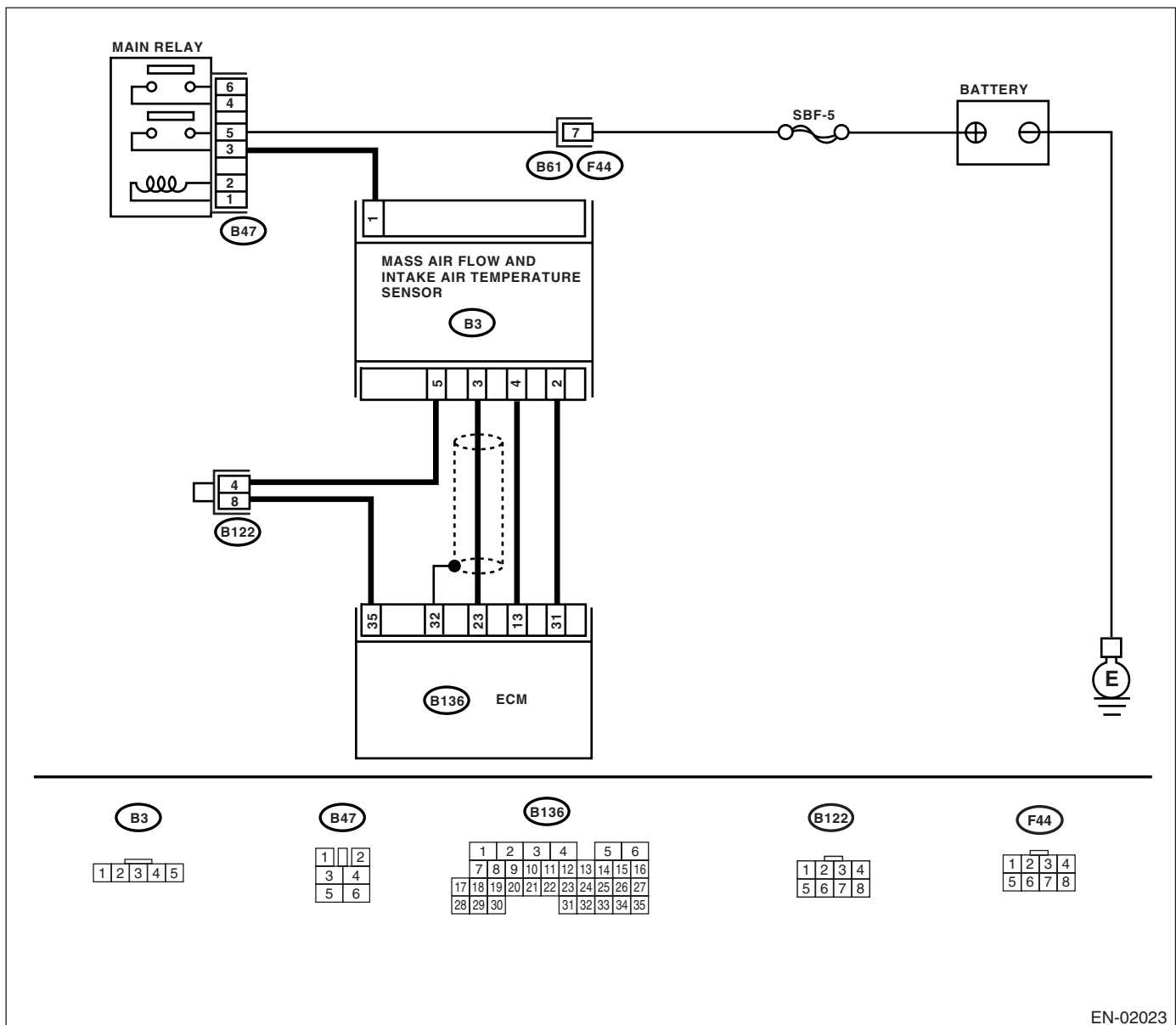

EN-02023

DIAGNOSTIC PROCEDURE WITH DIAGNOSTIC TROUBLE CODE (DTC)

ENGINE (DIAGNOSTICS)

Step	Check	Yes	No
1 CHECK ANY OTHER DTC ON DISPLAY.	Is any other DTC displayed?	Inspect the relevant DTC using "List of Diagnostic Trouble Code (DTC)". <Ref. to EN(H4DOTC)-68, List of Diagnostic Trouble Code (DTC).> NOTE: In this case, it is not necessary to inspect DTC P0111.	Go to step 2.
2 CHECK ENGINE COOLANT TEMPERATURE. 1) Start the engine and warm it up completely. 2) Measure the engine coolant temperature using Subaru Select Monitor or OBD-II general scan tool. NOTE: • Subaru Select Monitor For detailed operation procedure, refer to the "READ CURRENT DATA FOR ENGINE". <Ref. to EN(H4DOTC)-29, Subaru Select Monitor.> • OBD-II general scan tool For detailed operation procedures, refer to the OBD-II General Scan Tool Instruction Manual.	Is the engine coolant temperature 75°C (167°F) — 95°C (203°F)?	Replace the mass air flow and intake air temperature sensor. <Ref. to FU(H4DOTC)-30, Mass Air Flow and Intake Air Temperature Sensor.>	Inspect the DTC P0125 using "List of Diagnostic Trouble Code (DTC)". <Ref. to EN(H4DOTC)-68, List of Diagnostic Trouble Code (DTC).>

DIAGNOSTIC PROCEDURE WITH DIAGNOSTIC TROUBLE CODE (DTC)

ENGINE (DIAGNOSTICS)

O: DTC P0112 — INTAKE AIR TEMPERATURE CIRCUIT LOW INPUT —

DTC DETECTING CONDITION:

- Immediately at fault recognition
- GENERAL DESCRIPTION <Ref. to GD(H4DOTC)-37, DTC P0112 — INTAKE AIR TEMPERATURE CIRCUIT LOW INPUT —, Diagnostic Trouble Code (DTC) Detecting Criteria.>

TROUBLE SYMPTOM:

- Erroneous idling
- Poor driving performance

CAUTION:

After repair or replacement of faulty parts, conduct Clear Memory Mode <Ref. to EN(H4DOTC)-44, OPERATION, Clear Memory Mode.> and Inspection Mode <Ref. to EN(H4DOTC)-36, OPERATION, Inspection Mode.>.

WIRING DIAGRAM:

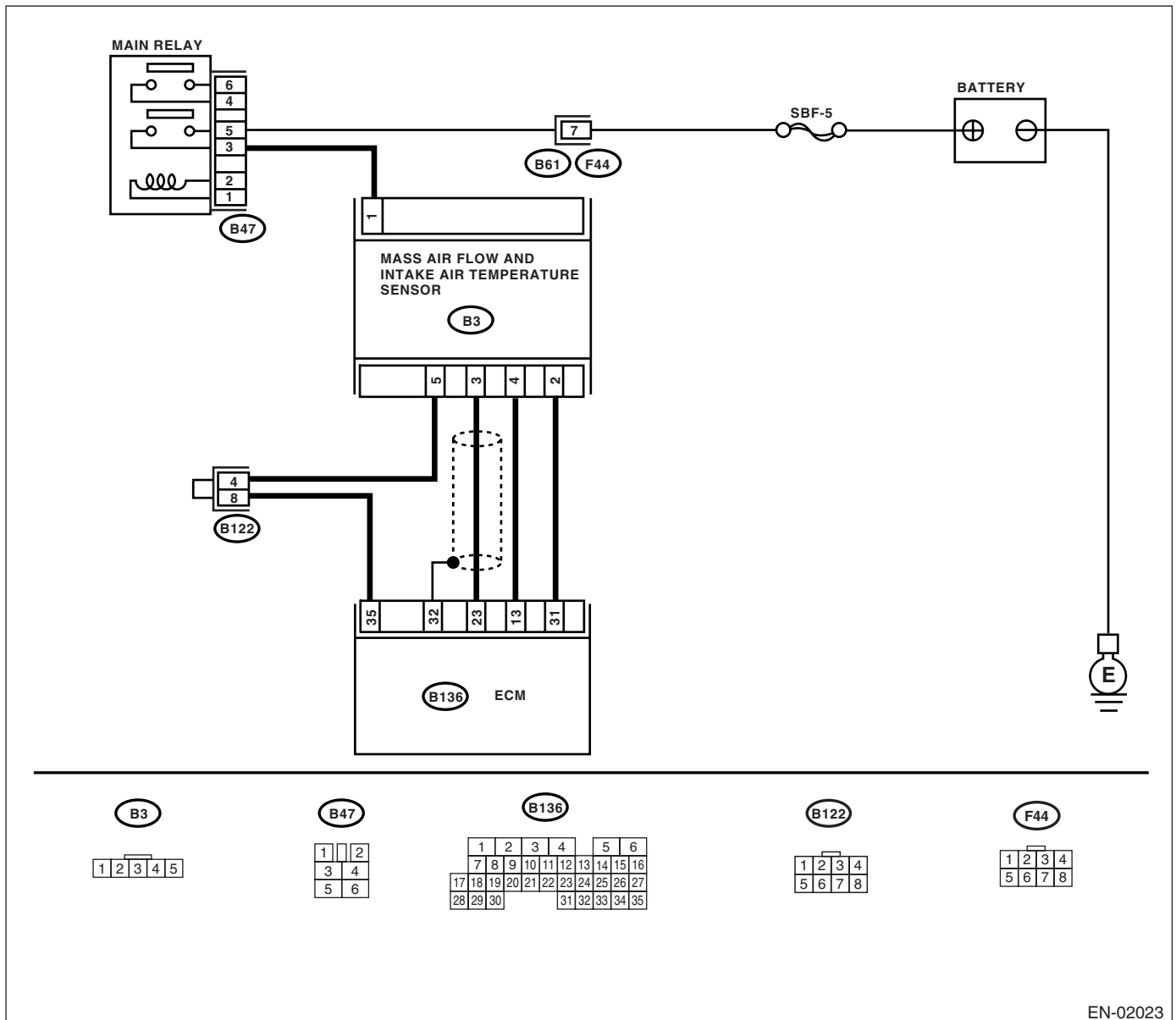

DIAGNOSTIC PROCEDURE WITH DIAGNOSTIC TROUBLE CODE (DTC)

ENGINE (DIAGNOSTICS)

Step	Check	Yes	No
<p>1</p> <p>CHECK CURRENT DATA.</p> <p>1) Start the engine.</p> <p>2) Read the data of intake air temperature sensor signal using Subaru Select Monitor or the OBD-II general scan tool.</p> <p>NOTE:</p> <ul style="list-style-type: none"> • Subaru Select Monitor <p>For detailed operation procedure, refer to the "READ CURRENT DATA FOR ENGINE". <Ref. to EN(H4DOTC)-29, Subaru Select Monitor.></p> <ul style="list-style-type: none"> • OBD-II general scan tool <p>For detailed operation procedure, refer to the OBD-II General Scan Tool Instruction Manual.</p>	<p>Is the temperature more than 55°C (131°F)?</p>	<p>Go to step 2.</p>	<p>Repair the poor contact.</p> <p>NOTE:</p> <p>In this case, repair the following:</p> <ul style="list-style-type: none"> • Poor contact mass air flow and intake air temperature sensor • Poor contact in ECM • Poor contact in joint connector
<p>2</p> <p>CHECK HARNESS BETWEEN MASS AIR FLOW AND INTAKE AIR TEMPERATURE SENSOR AND ECM CONNECTOR.</p> <p>1) Turn the ignition switch to OFF.</p> <p>2) Disconnect the connector from mass air flow and intake air temperature sensor.</p> <p>3) Turn the ignition switch to ON.</p> <p>4) Read the data of intake air temperature sensor signal using Subaru Select Monitor or the OBD-II general scan tool.</p> <p>NOTE:</p> <ul style="list-style-type: none"> • Subaru Select Monitor <p>For detailed operation procedure, refer to the "READ CURRENT DATA FOR ENGINE". <Ref. to EN(H4DOTC)-29, Subaru Select Monitor.></p> <ul style="list-style-type: none"> • OBD-II general scan tool <p>For detailed operation procedure, refer to the OBD-II General Scan Tool Instruction Manual.</p>	<p>Is the temperature less than -36°C (-33°F)?</p>	<p>Replace the mass air flow and intake air temperature sensor. <Ref. to FU(H4DOTC)-30, Mass Air Flow and Intake Air Temperature Sensor.></p>	<p>Repair the ground short circuit in harness between mass air flow and intake air temperature sensor and ECM connector.</p>

DIAGNOSTIC PROCEDURE WITH DIAGNOSTIC TROUBLE CODE (DTC)

ENGINE (DIAGNOSTICS)

P: DTC P0113 — INTAKE AIR TEMPERATURE CIRCUIT HIGH INPUT — DTC DETECTING CONDITION:

- Immediately at fault recognition
- GENERAL DESCRIPTION <Ref. to GD(H4DOTC)-39, DTC P0113 — INTAKE AIR TEMPERATURE CIRCUIT HIGH INPUT —, Diagnostic Trouble Code (DTC) Detecting Criteria.>

TROUBLE SYMPTOM:

- Erroneous idling
- Poor driving performance

CAUTION:

After repair or replacement of faulty parts, conduct Clear Memory Mode <Ref. to EN(H4DOTC)-44, OPERATION, Clear Memory Mode.> and Inspection Mode <Ref. to EN(H4DOTC)-36, OPERATION, Inspection Mode.>.

WIRING DIAGRAM:

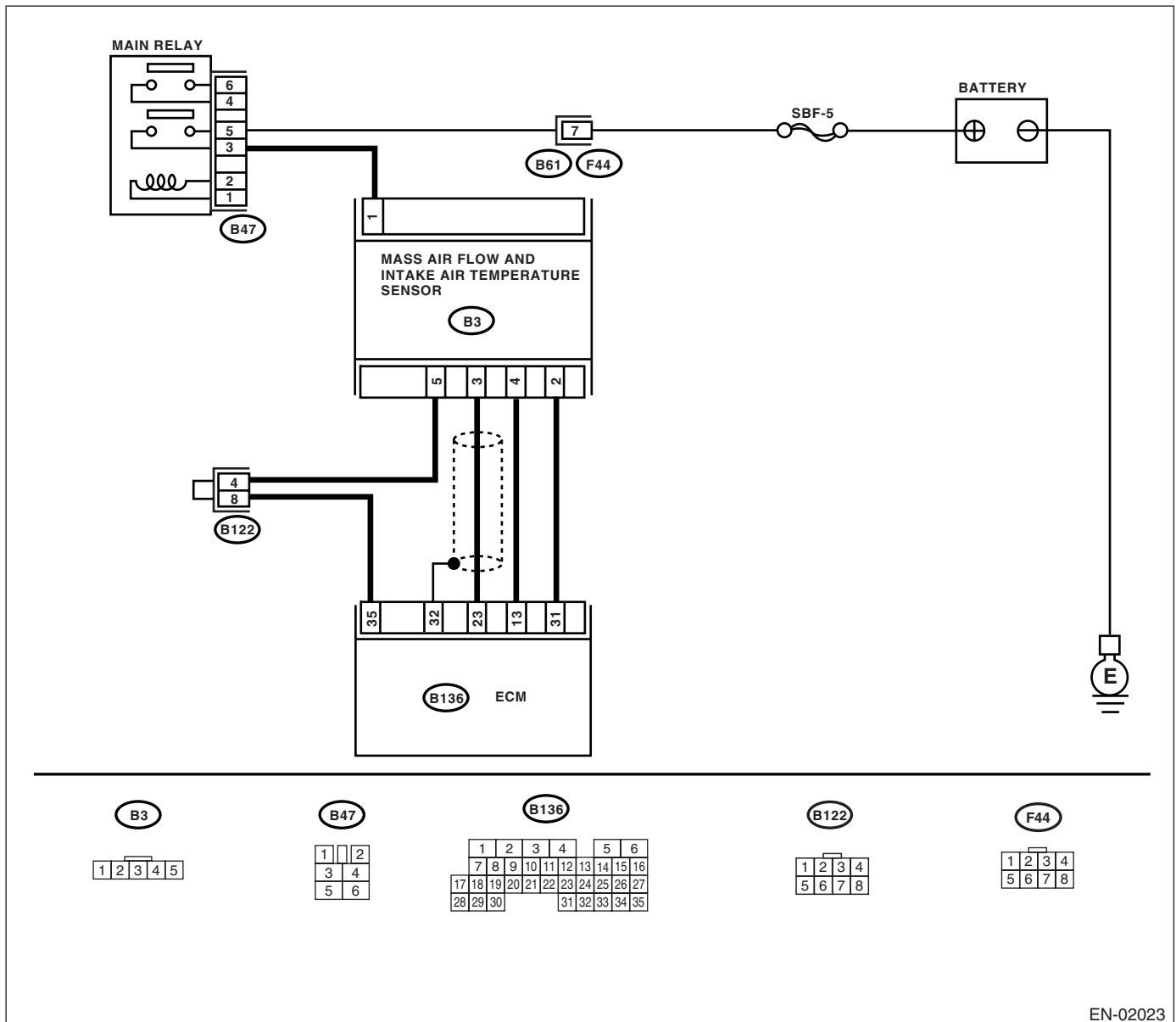

EN-02023

DIAGNOSTIC PROCEDURE WITH DIAGNOSTIC TROUBLE CODE (DTC)

ENGINE (DIAGNOSTICS)

Step	Check	Yes	No
<p>1</p> <p>CHECK CURRENT DATA.</p> <p>1) Start the engine.</p> <p>2) Read the data of intake air temperature sensor signal using Subaru Select Monitor or the OBD-II general scan tool.</p> <p>NOTE:</p> <ul style="list-style-type: none"> • Subaru Select Monitor <p>For detailed operation procedure, refer to the "READ CURRENT DATA FOR ENGINE". <Ref. to EN(H4DOTC)-29, Subaru Select Monitor.></p> <ul style="list-style-type: none"> • OBD-II general scan tool <p>For detailed operation procedure, refer to the OBD-II General Scan Tool Instruction Manual.</p>	<p>Is the temperature less than -36°C (-33°F)?</p>	<p>Go to step 2.</p>	<p>Repair the poor contact.</p> <p>NOTE:</p> <p>In this case, repair the following:</p> <ul style="list-style-type: none"> • Poor contact in mass air flow and intake air temperature sensor • Poor contact in ECM • Poor contact in joint connector
<p>2</p> <p>CHECK HARNESS BETWEEN MASS AIR FLOW AND INTAKE AIR TEMPERATURE SENSOR AND ECM CONNECTOR.</p> <p>1) Turn the ignition switch to OFF.</p> <p>2) Disconnect the connector from mass air flow and intake air temperature sensor.</p> <p>3) Measure the voltage between mass air flow and intake air temperature sensor connector and engine ground.</p> <p>Connector & terminal (B3) No. 4 (+) — Engine ground (-):</p>	<p>Is the voltage more than 10 V?</p>	<p>Repair the battery short circuit in harness between mass air flow and intake air temperature sensor and ECM connector.</p>	<p>Go to step 3.</p>
<p>3</p> <p>CHECK HARNESS BETWEEN MASS AIR FLOW AND INTAKE AIR TEMPERATURE SENSOR AND ECM CONNECTOR.</p> <p>1) Turn the ignition switch to ON.</p> <p>2) Measure the voltage between mass air flow and intake air temperature sensor connector and engine ground.</p> <p>Connector & terminal (B3) No. 4 (+) — Engine ground (-):</p>	<p>Is the voltage more than 10 V?</p>	<p>Repair the battery short circuit in harness between mass air flow and intake air temperature sensor and ECM connector.</p>	<p>Go to step 4.</p>
<p>4</p> <p>CHECK HARNESS BETWEEN MASS AIR FLOW AND INTAKE AIR TEMPERATURE SENSOR AND ECM CONNECTOR.</p> <p>Measure the voltage between mass air flow and intake air temperature sensor and manifold absolute pressure sensor connector and engine ground.</p> <p>Connector & terminal (B3) No. 4 (+) — Engine ground (-):</p>	<p>Is the voltage more than 4 V?</p>	<p>Go to step 5.</p>	<p>Repair the harness and connector.</p> <p>NOTE:</p> <p>In this case, repair the following:</p> <ul style="list-style-type: none"> • Open circuit in harness between mass air flow and intake air temperature sensor and ECM connector • Poor contact in mass air flow and intake air temperature sensor • Poor contact in ECM • Poor contact in joint connector

DIAGNOSTIC PROCEDURE WITH DIAGNOSTIC TROUBLE CODE (DTC)

ENGINE (DIAGNOSTICS)

Step	Check	Yes	No
<p>5</p> <p>CHECK HARNESS BETWEEN MASS AIR FLOW AND INTAKE AIR TEMPERATURE SENSOR AND ECM CONNECTOR.</p> <p>1) Turn the ignition switch to OFF.</p> <p>2) Measure the resistance of harness between mass air flow and intake air temperature sensor and engine ground.</p> <p>Connector & terminal (B3) No. 5 — Engine ground:</p>	<p>Is the resistance less than 5 Ω?</p>	<p>Replace the mass air flow and intake air temperature sensor. <Ref. to FU(H4DOTC)-30, Mass Air Flow and Intake Air Temperature Sensor.></p>	<p>Repair the harness and connector.</p> <p>NOTE: In this case, repair the following:</p> <ul style="list-style-type: none"> • Open circuit in harness between mass air flow and intake air temperature sensor and ECM connector • Poor contact in mass air flow and intake air temperature sensor • Poor contact in ECM • Poor contact in joint connector

DIAGNOSTIC PROCEDURE WITH DIAGNOSTIC TROUBLE CODE (DTC)

ENGINE (DIAGNOSTICS)

Q: DTC P0117 — ENGINE COOLANT TEMPERATURE CIRCUIT LOW INPUT — DTC DETECTING CONDITION:

- Immediately at fault recognition
- GENERAL DESCRIPTION <Ref. to GD(H4DOTC)-41, DTC P0117 — ENGINE COOLANT TEMPERATURE CIRCUIT LOW INPUT —, Diagnostic Trouble Code (DTC) Detecting Criteria.>

TROUBLE SYMPTOM:

- Hard to start
- Erroneous idling
- Poor driving performance

CAUTION:

After repair or replacement of faulty parts, conduct Clear Memory Mode <Ref. to EN(H4DOTC)-44, OPERATION, Clear Memory Mode.> and Inspection Mode <Ref. to EN(H4DOTC)-36, OPERATION, Inspection Mode.>.

WIRING DIAGRAM:

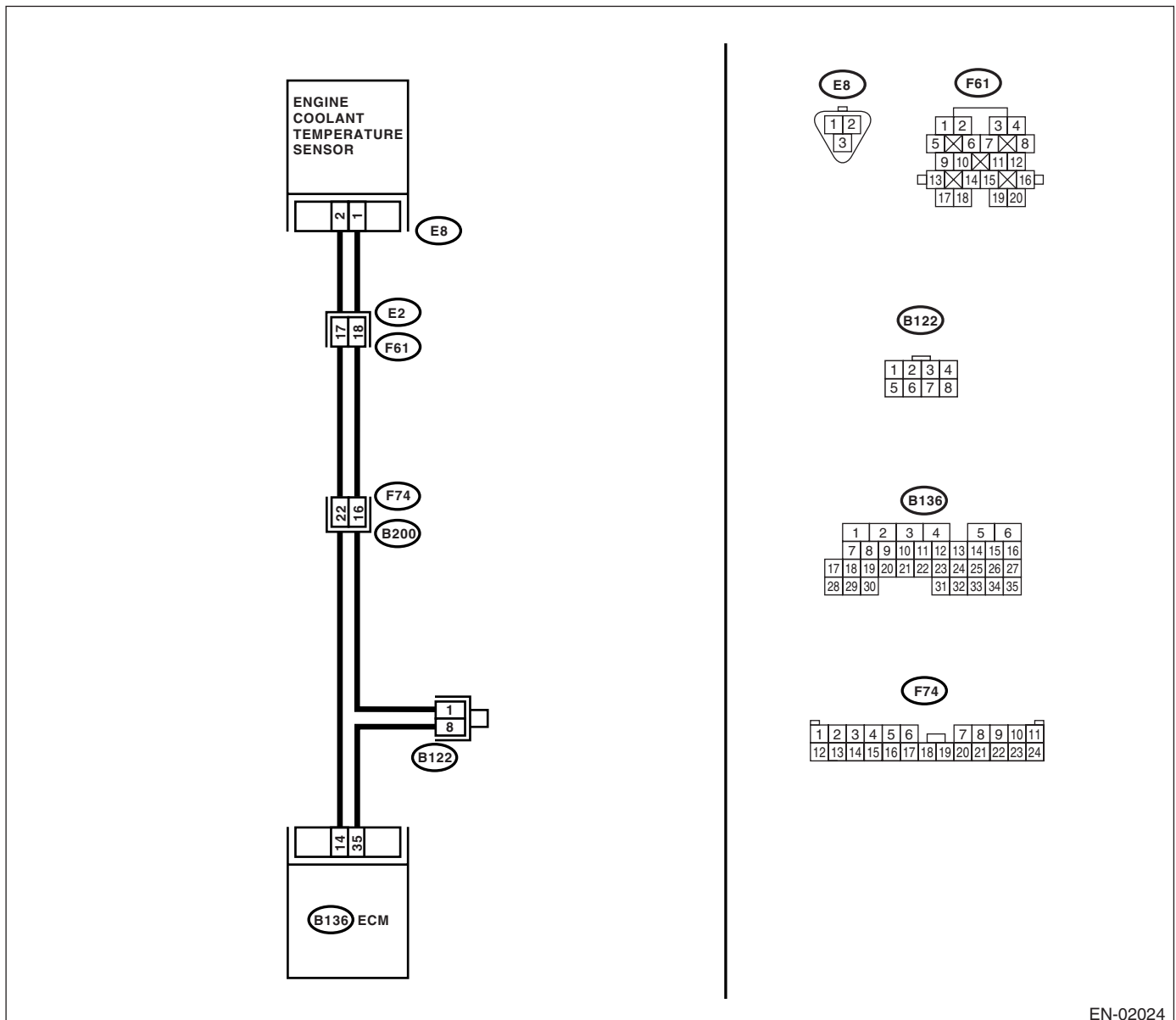

EN-02024

DIAGNOSTIC PROCEDURE WITH DIAGNOSTIC TROUBLE CODE (DTC)

ENGINE (DIAGNOSTICS)

Step	Check	Yes	No
<p>1</p> <p>CHECK CURRENT DATA.</p> <p>1) Start the engine.</p> <p>2) Read the data of engine coolant temperature sensor signal using Subaru Select Monitor or OBD-II general scan tool.</p> <p>NOTE:</p> <ul style="list-style-type: none"> • Subaru Select Monitor <p>For detailed operation procedure, refer to the "READ CURRENT DATA FOR ENGINE". <Ref. to EN(H4DOTC)-29, Subaru Select Monitor.></p> <ul style="list-style-type: none"> • OBD-II general scan tool <p>For detailed operation procedures, refer to the OBD-II General Scan Tool Instruction Manual.</p>	<p>Is the temperature more than 120°C (248°F)?</p>	<p>Go to step 2.</p>	<p>Repair the poor contact.</p> <p>NOTE:</p> <p>In this case, repair the following:</p> <ul style="list-style-type: none"> • Poor contact in engine coolant temperature sensor • Poor contact in ECM • Poor contact in coupling connector • Poor contact in joint connector
<p>2</p> <p>CHECK HARNESS BETWEEN ENGINE COOLANT TEMPERATURE SENSOR AND ECM CONNECTOR.</p> <p>1) Turn the ignition switch to OFF.</p> <p>2) Disconnect the connector from engine coolant temperature sensor.</p> <p>3) Turn the ignition switch to ON.</p> <p>4) Read the data of engine coolant temperature sensor signal using Subaru Select Monitor or OBD-II general scan tool.</p> <p>NOTE:</p> <ul style="list-style-type: none"> • Subaru Select Monitor <p>For detailed operation procedure, refer to the "READ CURRENT DATA FOR ENGINE". <Ref. to EN(H4DOTC)-29, Subaru Select Monitor.></p> <ul style="list-style-type: none"> • OBD-II general scan tool <p>For detailed operation procedures, refer to the OBD-II General Scan Tool Instruction Manual.</p>	<p>Is the temperature more than -40°C (-40°F)?</p>	<p>Replace the engine coolant temperature sensor. <Ref. to FU(H4DOTC)-26, Engine Coolant Temperature Sensor.></p>	<p>Repair the ground short circuit in harness between engine coolant temperature sensor and ECM connector.</p>

DIAGNOSTIC PROCEDURE WITH DIAGNOSTIC TROUBLE CODE (DTC)

ENGINE (DIAGNOSTICS)

R: DTC P0118 — ENGINE COOLANT TEMPERATURE CIRCUIT HIGH INPUT — DTC DETECTING CONDITION:

- Immediately at fault recognition
- GENERAL DESCRIPTION <Ref. to GD(H4DOTC)-43, DTC P0118 — ENGINE COOLANT TEMPERATURE CIRCUIT HIGH INPUT —, Diagnostic Trouble Code (DTC) Detecting Criteria.>

TROUBLE SYMPTOM:

- Hard to start
- Erroneous idling
- Poor driving performance

CAUTION:

After repair or replacement of faulty parts, conduct Clear Memory Mode <Ref. to EN(H4DOTC)-44, OPERATION, Clear Memory Mode.> and Inspection Mode <Ref. to EN(H4DOTC)-36, OPERATION, Inspection Mode.>.

WIRING DIAGRAM:

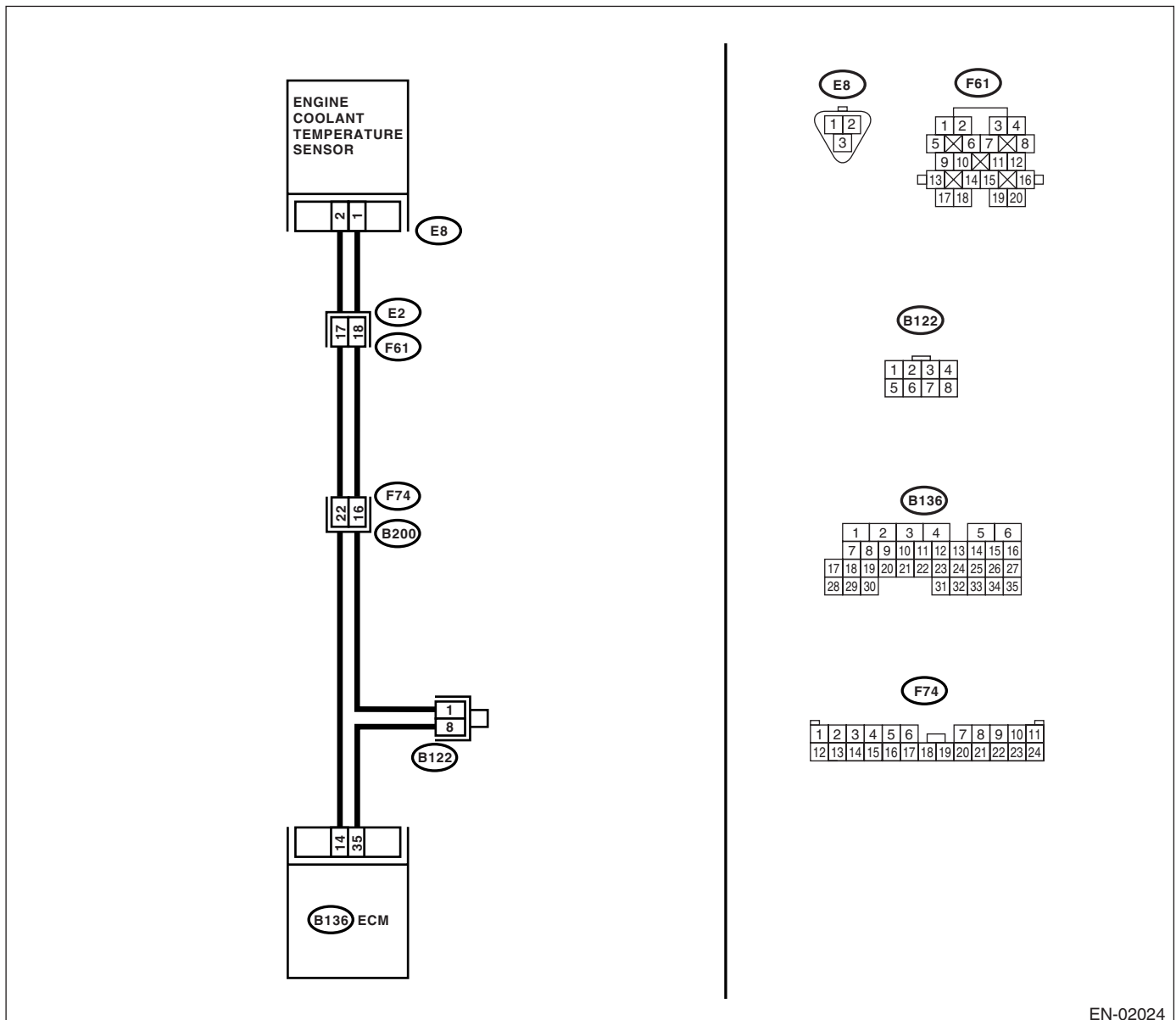

EN-02024

DIAGNOSTIC PROCEDURE WITH DIAGNOSTIC TROUBLE CODE (DTC)

ENGINE (DIAGNOSTICS)

Step	Check	Yes	No
<p>1</p> <p>CHECK CURRENT DATA.</p> <p>1) Start the engine.</p> <p>2) Read the data of engine coolant temperature sensor signal using Subaru Select Monitor or OBD-II general scan tool.</p> <p>NOTE:</p> <ul style="list-style-type: none"> Subaru Select Monitor <p>For detailed operation procedure, refer to the "READ CURRENT DATA FOR ENGINE". <Ref. to EN(H4DOTC)-29, Subaru Select Monitor.></p> <ul style="list-style-type: none"> OBD-II general scan tool <p>For detailed operation procedures, refer to the OBD-II General Scan Tool Instruction Manual.</p>	<p>Is the temperature less than -40°C (-40°F)?</p>	<p>Go to step 2.</p>	<p>Repair the poor contact.</p> <p>NOTE:</p> <p>In this case, repair the following:</p> <ul style="list-style-type: none"> Poor contact in engine coolant temperature sensor Poor contact in ECM Poor contact in coupling connector Poor contact in joint connector
<p>2</p> <p>CHECK HARNESS BETWEEN ENGINE COOLANT TEMPERATURE SENSOR AND ECM CONNECTOR.</p> <p>1) Turn the ignition switch to OFF.</p> <p>2) Disconnect the connector from engine coolant temperature sensor.</p> <p>3) Measure the voltage between engine coolant temperature sensor connector and engine ground.</p> <p>Connector & terminal (E8) No. 2 (+) — Engine ground (-):</p>	<p>Is the voltage more than 10 V?</p>	<p>Repair the battery short circuit in harness between ECM and engine coolant temperature sensor connector.</p>	<p>Go to step 3.</p>
<p>3</p> <p>CHECK HARNESS BETWEEN ENGINE COOLANT TEMPERATURE SENSOR AND ECM CONNECTOR.</p> <p>1) Turn the ignition switch to ON.</p> <p>2) Measure the voltage between engine coolant temperature sensor connector and engine ground.</p> <p>Connector & terminal (E8) No. 2 (+) — Engine ground (-):</p>	<p>Is the voltage more than 10 V?</p>	<p>Repair the battery short circuit in harness between ECM and engine coolant temperature sensor connector.</p>	<p>Go to step 4.</p>
<p>4</p> <p>CHECK HARNESS BETWEEN ENGINE COOLANT TEMPERATURE SENSOR AND ECM CONNECTOR.</p> <p>Measure the voltage between engine coolant temperature sensor connector and engine ground.</p> <p>Connector & terminal (E8) No. 2 (+) — Engine ground (-):</p>	<p>Is the voltage more than 4 V?</p>	<p>Go to step 5.</p>	<p>Repair the harness and connector.</p> <p>NOTE:</p> <p>In this case, repair the following:</p> <ul style="list-style-type: none"> Open circuit in harness between ECM and engine coolant temperature sensor connector Poor contact in engine coolant temperature sensor connector Poor contact in ECM connector Poor contact in coupling connector Poor contact in joint connector

DIAGNOSTIC PROCEDURE WITH DIAGNOSTIC TROUBLE CODE (DTC)

ENGINE (DIAGNOSTICS)

Step	Check	Yes	No
<p>5</p> <p>CHECK HARNESS BETWEEN ENGINE COOLANT TEMPERATURE SENSOR AND ECM CONNECTOR.</p> <p>1) Turn the ignition switch to OFF.</p> <p>2) Measure the resistance of harness between engine coolant temperature sensor connector and engine ground.</p> <p>Connector & terminal (E8) No. 1 — Engine ground:</p>	<p>Is the resistance less than 5 Ω?</p>	<p>Replace the engine coolant temperature sensor. <Ref. to FU(H4DOTC)-26, Engine Coolant Temperature Sensor.></p>	<p>Repair the harness and connector.</p> <p>NOTE: In this case, repair the following:</p> <ul style="list-style-type: none"> • Open circuit in harness between ECM and engine coolant temperature sensor connector • Poor contact in engine coolant temperature sensor connector • Poor contact in ECM connector • Poor contact in coupling connector • Poor contact in joint connector

DIAGNOSTIC PROCEDURE WITH DIAGNOSTIC TROUBLE CODE (DTC)

ENGINE (DIAGNOSTICS)

S: DTC P0122 — THROTTLE/PEDAL POSITION SENSOR/SWITCH “A” CIRCUIT LOW INPUT —

DTC DETECTING CONDITION:

- Immediately at fault recognition
- GENERAL DESCRIPTION <Ref. to GD(H4DOTC)-45, DTC P0122 — THROTTLE/PEDAL POSITION SENSOR/SWITCH “A” CIRCUIT LOW INPUT —, Diagnostic Trouble Code (DTC) Detecting Criteria.>

TROUBLE SYMPTOM:

- Erroneous idling
- Engine stalls.
- Poor driving performance

CAUTION:

After repair or replacement of faulty parts, conduct Clear Memory Mode <Ref. to EN(H4DOTC)-44, OPERATION, Clear Memory Mode.> and Inspection Mode <Ref. to EN(H4DOTC)-36, OPERATION, Inspection Mode.>.

DIAGNOSTIC PROCEDURE WITH DIAGNOSTIC TROUBLE CODE (DTC) ENGINE (DIAGNOSTICS)

WIRING DIAGRAM:

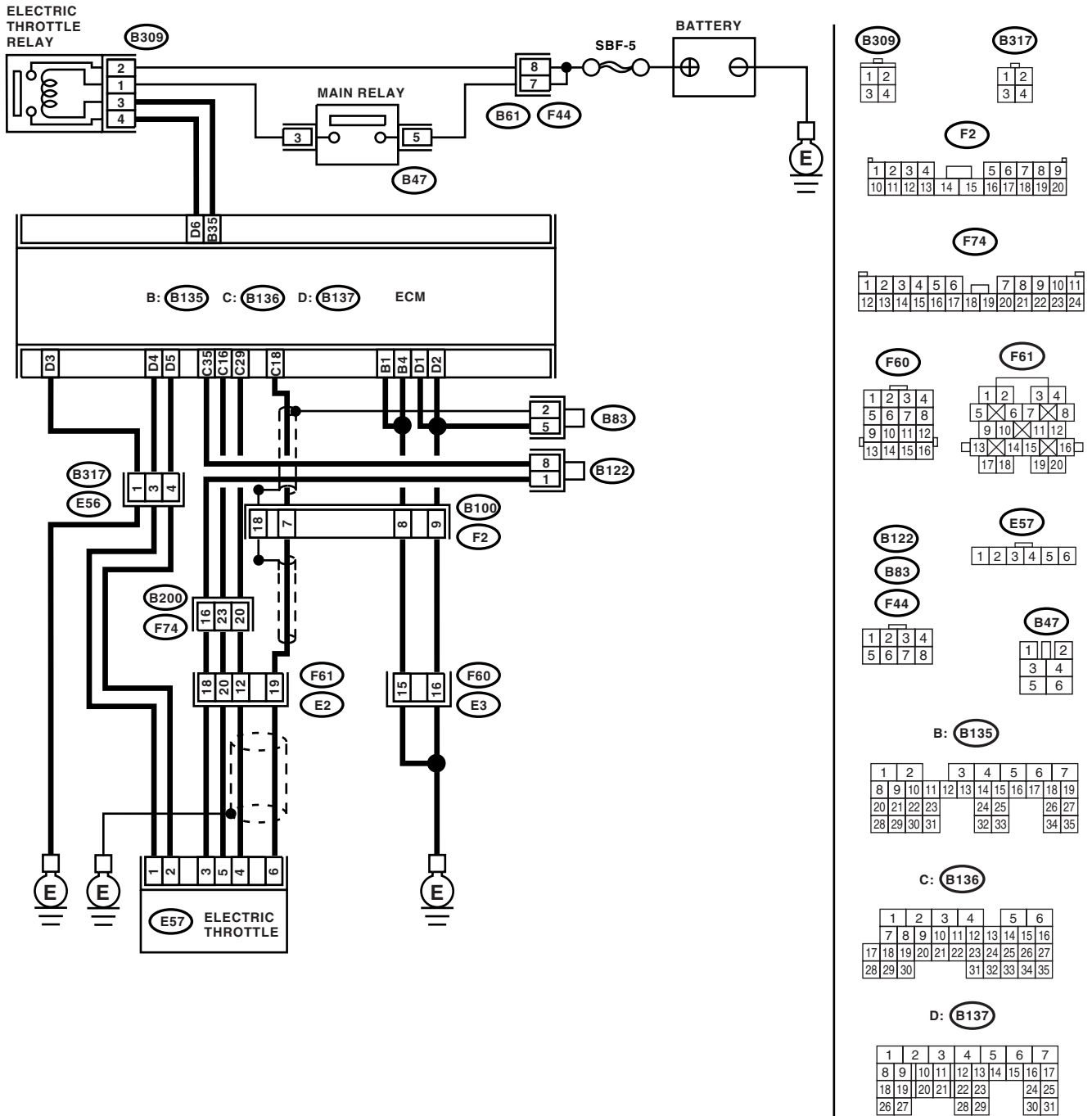

EN-02025

DIAGNOSTIC PROCEDURE WITH DIAGNOSTIC TROUBLE CODE (DTC)

ENGINE (DIAGNOSTICS)

Step	Check	Yes	No
1 CHECK OUTPUT VOLTAGE OF SENSOR. 1) Turn the ignition switch to ON. 2) Measure the voltage between ECM connector terminals. <i>Connector & terminal</i> <i>(B136) No. 29 (+) — (B136) No. 35 (-):</i> 3) Shake the ECM harness and connector, engine harness connectors and electric throttle.	Is the voltage more than 0.4 V?	Go to step 2.	Go to step 3.
2 CHECK POOR CONTACT IN CONNECTORS. Check poor contact in connectors between ECM and electric throttle.	Is there poor contact in the connectors between ECM and electric throttle?	Repair the poor contact in connectors.	Connector has returned to a normal condition at this time. A temporary poor contact of the connector may be the cause.
3 CHECK HARNESS BETWEEN ECM AND ELECTRIC THROTTLE. 1) Turn the ignition switch to OFF. 2) Disconnect the connector from ECM. 3) Disconnect the connector from electric throttle. 4) Measure the resistance between ECM connector and electric throttle connector. <i>Connector & terminal</i> <i>(B136) No. 16 — (E57) No. 5:</i>	Is the resistance less than 1 Ω ?	Go to step 4.	Repair open of harness connector.
4 CHECK HARNESS BETWEEN ECM AND ELECTRIC THROTTLE. Measure the resistance between ECM connector and chassis ground. <i>Connector & terminal</i> <i>(B136) No. 18 — Chassis ground:</i> <i>(B136) No. 16 — Chassis ground:</i>	Is the resistance more than 1 M Ω ?	Go to step 5.	Repair the chassis short of harness.
5 CHECK POWER SURPLY TO SENSOR. 1) Connect the ECM connector. 2) Turn the ignition switch to ON. 3) Measure the voltage between electric throttle connector and engine ground. <i>Connector & terminal</i> <i>(E57) No. 5 (+) — Engine ground (-):</i> 4) Shake the ECM harness and connector, engine harness connectors, while monitoring value of voltage meter.	Is the voltage 4.5 — 5.5 V?	Go to step 6.	Repair the poor contact in ECM connector. If problem persists, replace the ECM. <Ref. to FU(H4DOTC)-42, Engine Control Module (ECM).>
6 CHECK SHORT OF ECM. 1) Turn the ignition switch to OFF. 2) Measure the resistance between electric throttle connector and engine ground. <i>Connector & terminal</i> <i>(E57) No. 6 — Engine ground:</i>	Is the resistance more than 10 Ω ?	Repair the poor contact in electric throttle connector. If problem persists, replace the accelerator position sensor.	Repair the poor the contact in ECM connector. If problem persists, replace the ECM. <Ref. to FU(H4DOTC)-42, Engine Control Module (ECM).>

T: DTC P0123 — THROTTLE/PEDAL POSITION SENSOR/SWITCH “A” CIRCUIT HIGH INPUT —

DTC DETECTING CONDITION:

- Immediately at fault recognition
- GENERAL DESCRIPTION <Ref. to GD(H4DOTC)-47, DTC P0123 — THROTTLE/PEDAL POSITION SENSOR/SWITCH “A” CIRCUIT HIGH INPUT —, Diagnostic Trouble Code (DTC) Detecting Criteria.>

TROUBLE SYMPTOM:

- Erroneous idling
- Engine stalls.
- Poor driving performance

CAUTION:

After repair or replacement of faulty parts, conduct Clear Memory Mode <Ref. to EN(H4DOTC)-44, OPERATION, Clear Memory Mode.> and Inspection Mode <Ref. to EN(H4DOTC)-36, OPERATION, Inspection Mode.>.

DIAGNOSTIC PROCEDURE WITH DIAGNOSTIC TROUBLE CODE (DTC) ENGINE (DIAGNOSTICS)

WIRING DIAGRAM:

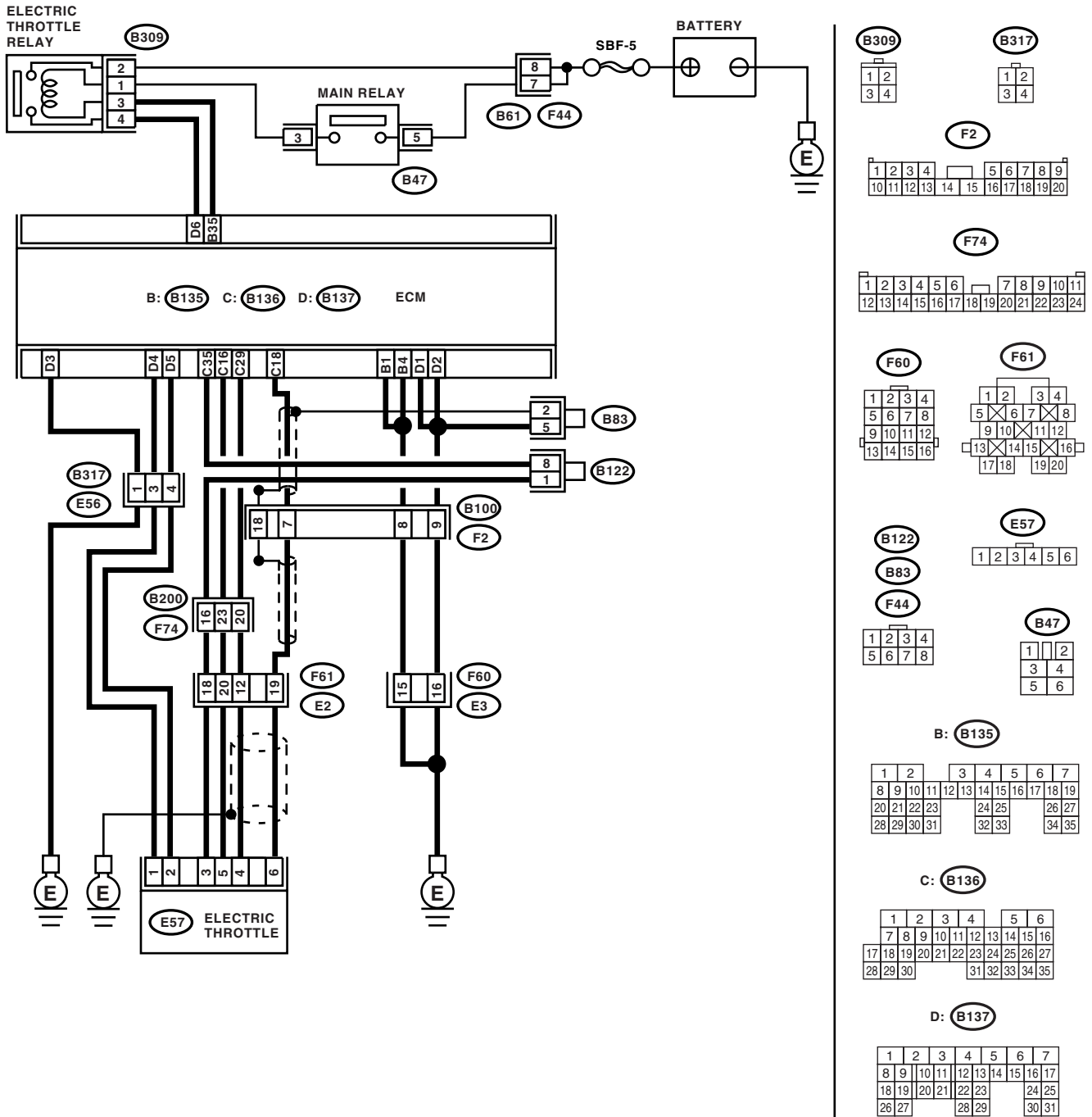

EN-02025

DIAGNOSTIC PROCEDURE WITH DIAGNOSTIC TROUBLE CODE (DTC)

ENGINE (DIAGNOSTICS)

Step	Check	Yes	No
1 CHECK OUTPUT VOLTAGE OF SENSOR. 1) Turn the ignition switch to ON. 2) Read the data of main throttle sensor signals, using the Subaru Select Monitor. 3) Shake the ECM harness and connector, engine harness connectors, electric throttle connector harness while monitoring value of voltage meter.	Is the voltage less than 4.63 V?	Go to step 2.	Go to step 3.
2 CHECK POOR CONTACT IN CONNECTORS. Check poor contact in connectors between ECM and electric throttle.	Is there poor contact in the connectors between ECM and electric throttle?	Repair the poor contact in connectors.	Connector has returned to a normal condition at this time. A temporary poor contact of the connector may be the cause.
3 CHECK HARNESS BETWEEN ECM AND ELECTRIC THROTTLE. 1) Turn the ignition switch to OFF. 2) Disconnect the connectors from ECM. 3) Disconnect the connectors from electric throttle. 4) Measure the resistance between ECM connector and electric throttle connector. <i>Connector & terminal</i> <i>(B136) No. 18 — (E57) No. 6:</i> <i>(B136) No. 35 — (E57) No. 3:</i>	Is the resistance less than 1 Ω ?	Go to step 4.	Repair the open of harness connector.
4 CHECK HARNESS BETWEEN ECM AND ELECTRIC THROTTLE. 1) Connect the ECM connector. 2) Measure the resistance between the electric throttle connector and engine ground. <i>Connector & terminal</i> <i>(E57) No. 3 — Engine ground:</i>	Is the resistance less than 1 Ω ?	Go to step 5.	Repair the poor contact in ECM connector. If the problem persists, replace the ECM. <Ref. to FU(H4DOTC)-42, Engine Control Module (ECM).>
5 CHECK HARNESS BETWEEN ECM AND ELECTRIC THROTTLE. 1) Turn the ignition switch to ON. 2) Measure the voltage between electric throttle connector and engine ground. <i>Connector & terminal</i> <i>(E57) No. 5 (+) — Engine ground (-):</i> 3) Shake the ECM harness and connector, engine harness connectors, while monitoring value of voltage meter.	Is the voltage more than 10 V?	Go to step 6.	Repair the battery short of harness between ECM connector and electric throttle connector.
6 CHECK POWER SUPPLY TO SENSOR. 1) Measure the voltage between the electric throttle connector and engine ground. <i>Connector & terminal</i> <i>(E57) No. 6 (+) — Engine ground (-):</i> 2) Shake the ECM harness and connector, engine harness connectors, while monitoring value of voltage meter.	Is the voltage less than 10 V?	Go to step 7.	Repair the short of harness between ECM connector and electric throttle connector.

DIAGNOSTIC PROCEDURE WITH DIAGNOSTIC TROUBLE CODE (DTC)

ENGINE (DIAGNOSTICS)

	Step	Check	Yes	No
7	CHECK HARNESS BETWEEN ECM AND ELECTRIC THROTTLE. 1) Turn the ignition switch to OFF. 2) Disconnect the connector from ECM. 3) Measure the resistance between ECM connectors. Connector & terminal (B136) No. 18 — (B136) No. 16:	Is the resistance more than 1 M Ω ?	Repair the poor contact in harness. Replace the electric throttle.	Repair the short of harness of power supply to sensor.

DIAGNOSTIC PROCEDURE WITH DIAGNOSTIC TROUBLE CODE (DTC)

ENGINE (DIAGNOSTICS)

U: DTC P0125 — INSUFFICIENT COOLANT TEMPERATURE FOR CLOSED LOOP FUEL CONTROL —

DTC DETECTING CONDITION:

- Two consecutive driving cycles with fault
- GENERAL DESCRIPTION <Ref. to GD(H4DOTC)-49, DTC P0125 — INSUFFICIENT COOLANT TEMPERATURE FOR CLOSED LOOP FUEL CONTROL —, Diagnostic Trouble Code (DTC) Detecting Criteria.>

TROUBLE SYMPTOM:

Engine will not return to idling.

CAUTION:

After repair or replacement of faulty parts, conduct Clear Memory Mode <Ref. to EN(H4DOTC)-44, OPERATION, Clear Memory Mode.> and Inspection Mode <Ref. to EN(H4DOTC)-36, OPERATION, Inspection Mode.>.

WIRING DIAGRAM:

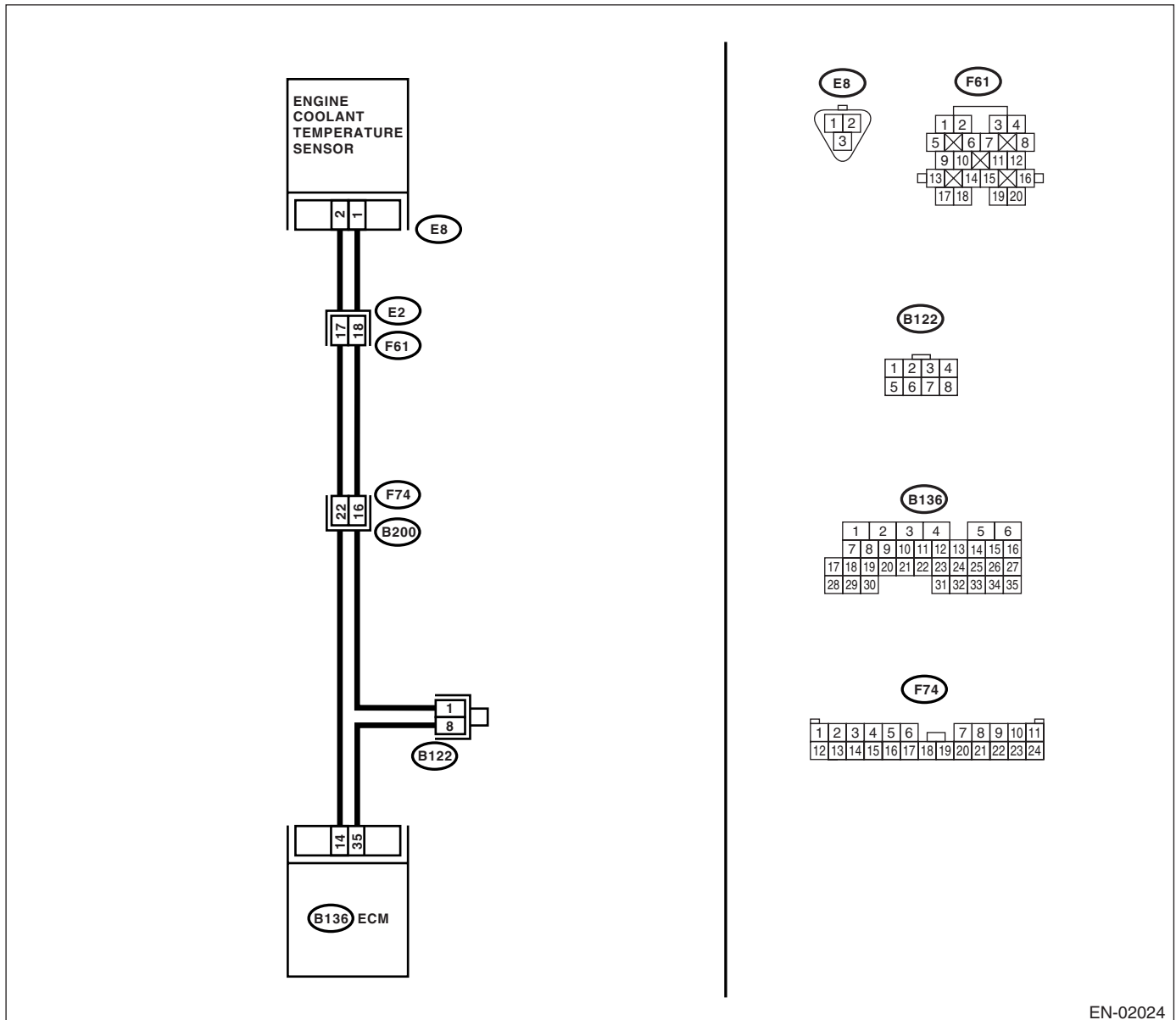

EN-02024

DIAGNOSTIC PROCEDURE WITH DIAGNOSTIC TROUBLE CODE (DTC)

ENGINE (DIAGNOSTICS)

Step	Check	Yes	No
1 CHECK ANY OTHER DTC ON DISPLAY.	Is any other DTC displayed?	Inspect the relevant DTC using "List of Diagnostic Trouble Code (DTC)". <Ref. to EN(H4DOTC)-68, List of Diagnostic Trouble Code (DTC).> NOTE: In this case, it is not necessary to inspect DTC P0125.	Go to step 2.
2 CHECK ENGINE COOLING SYSTEM. NOTE: Check the following items. <ul style="list-style-type: none">• Thermostat open stuck• Coolant level• Coolant freeze• Tire diameter	Is there a fault in engine cooling system?	Replace the thermostat. <Ref. to CO(H4SO)-24, Thermostat.>	Replace the engine coolant temperature sensor. <Ref. to FU(H4DOTC)-26, Engine Coolant Temperature Sensor.>

DIAGNOSTIC PROCEDURE WITH DIAGNOSTIC TROUBLE CODE (DTC)

ENGINE (DIAGNOSTICS)

V: DTC P0128 — COOLANT THERMOSTAT (COOLANT TEMPERATURE BELOW THERMOSTAT REGULATING TEMPERATURE) —

DTC DETECTING CONDITION:

- Two consecutive driving cycles with fault
- GENERAL DESCRIPTION <Ref. to GD(H4DOTC)-51, DTC P0128 — COOLANT THERMOSTAT (COOLANT TEMPERATURE BELOW THERMOSTAT REGULATING TEMPERATURE) —, Diagnostic Trouble Code (DTC) Detecting Criteria.>

TROUBLE SYMPTOM:

Thermostat remains open.

CAUTION:

After repair or replacement of faulty parts, conduct Clear Memory Mode <Ref. to EN(H4DOTC)-44, OPERATION, Clear Memory Mode.> and Inspection Mode <Ref. to EN(H4DOTC)-36, OPERATION, Inspection Mode.>.

Step	Check	Yes	No	
1	CHECK VEHICLE CONDITION.	Was the vehicle driven or idled with the engine partially submerged under water?	In this case, it is not necessary to inspect DTC P0128.	Go to step 2.
2	CHECK FOR OTHER DTC ON DISPLAY.	Is any other DTC displayed?	Inspect the relevant DTC using "List of Diagnostic Trouble Codes (DTC)". <Ref. to EN(H4DOTC)-68, List of Diagnostic Trouble Code (DTC).>	Go to step 3.
3	CHECK ENGINE COOLANT.	Are coolant level and mixture ratio of cooling water to anti-freeze solution correct?	Go to step 4.	Replace the engine coolant. <Ref. to CO(H4SO)-17, REPLACEMENT, Engine Coolant.>
4	CHECK RADIATOR FAN. 1) Start the engine. 2) Check radiator fan operation.	Does the radiator fan continuously rotate for more than 3 minutes during idling?	Repair radiator fan circuit. <Ref. to CO(H4SO)-33, Radiator Main Fan and Fan Motor.> and <Ref. to CO(H4SO)-39, Radiator Sub Fan and Fan Motor.>	Replace the thermostat. <Ref. to CO(H4SO)-24, Thermostat.>

DIAGNOSTIC PROCEDURE WITH DIAGNOSTIC TROUBLE CODE (DTC)

ENGINE (DIAGNOSTICS)

W: DTC P0129 — ATMOSPHERIC PRESSURE SENSOR CIRCUIT RANGE/PERFORMANCE —

DTC DETECTING CONDITION:

- Two consecutive driving cycles with fault
- GENERAL DESCRIPTION <Ref. to GD(H4DOTC)-53, DTC P0129 — BAROMETRIC PRESSURE TOO LOW —, Diagnostic Trouble Code (DTC) Detecting Criteria.>

CAUTION:

After repair or replacement of faulty parts, conduct Clear Memory Mode <Ref. to EN(H4DOTC)-44, OPERATION, Clear Memory Mode.> and Inspection Mode <Ref. to EN(H4DOTC)-36, OPERATION, Inspection Mode.>.

Step	Check	Yes	No
1 CHECK ANY OTHER DTC ON DISPLAY.	Is any other DTC displayed?	Replace the ECM. <Ref. to FU(H4DOTC)-42, Engine Control Module (ECM).> NOTE: Atmospheric pres- sure sensor is built into ECM.	NOTE: It is not necessary to inspect DTC P0129.

DIAGNOSTIC PROCEDURE WITH DIAGNOSTIC TROUBLE CODE (DTC)

ENGINE (DIAGNOSTICS)

X: DTC P0131 — O₂ SENSOR CIRCUIT LOW VOLTAGE (BANK 1 SENSOR 1) — DTC DETECTING CONDITION:

- Immediately at fault recognition
- GENERAL DESCRIPTION <Ref. to GD(H4DOTC)-54, DTC P0131 — O₂ SENSOR CIRCUIT LOW VOLTAGE (BANK 1 SENSOR 1) —, Diagnostic Trouble Code (DTC) Detecting Criteria.>

CAUTION:

After repair or replacement of faulty parts, conduct Clear Memory Mode <Ref. to EN(H4DOTC)-44, OPERATION, Clear Memory Mode.> and Inspection Mode <Ref. to EN(H4DOTC)-36, OPERATION, Inspection Mode.>.

WIRING DIAGRAM:

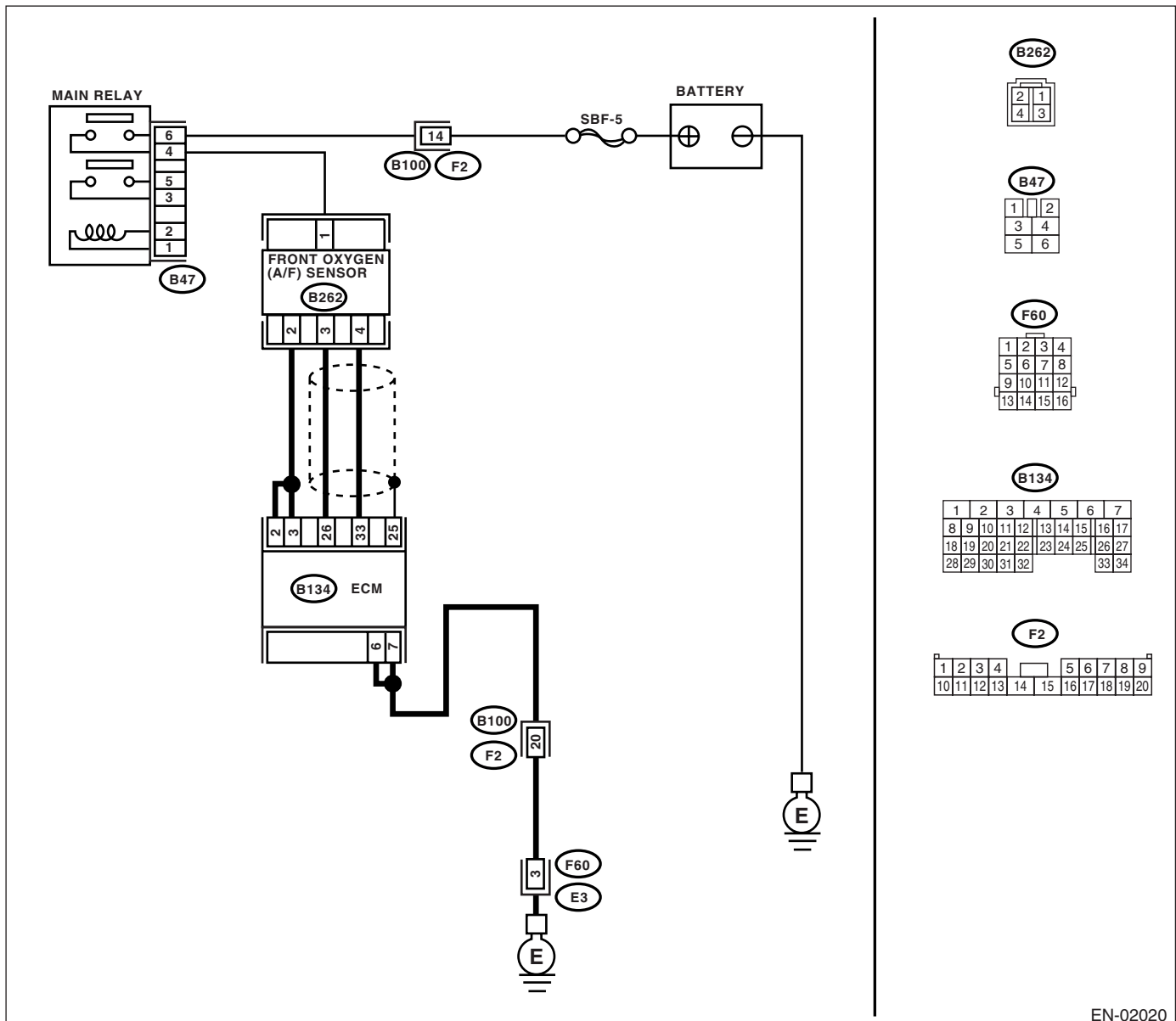

EN-02020

DIAGNOSTIC PROCEDURE WITH DIAGNOSTIC TROUBLE CODE (DTC)

ENGINE (DIAGNOSTICS)

	Step	Check	Yes	No
1	<p>CHECK HARNESS BETWEEN ECM AND FRONT OXYGEN (A/F) SENSOR CONNECTOR.</p> <p>1) Turn the ignition switch to OFF. 2) Disconnect the connectors from ECM and front oxygen (A/F) sensor connector. 3) Measure the resistance of harness between ECM and front oxygen (A/F) sensor connector.</p> <p>Connector & terminal (B134) No. 26 — Chassis ground: (B134) No. 33 — Chassis ground:</p>	Is the resistance more than 1 M Ω ?	Replace the front oxygen (A/F) sensor. <Ref. to FU(H4DOTC)-37, Front Oxygen (A/F) Sensor.>	Repair ground short circuit in harness between ECM and front oxygen (A/F) sensor connector.

DIAGNOSTIC PROCEDURE WITH DIAGNOSTIC TROUBLE CODE (DTC)

ENGINE (DIAGNOSTICS)

Y: DTC P0132 — O₂ SENSOR CIRCUIT HIGH VOLTAGE (BANK 1 SENSOR 1) — DTC DETECTING CONDITION:

- Immediately at fault recognition
- GENERAL DESCRIPTION <Ref. to GD(H4DOTC)-56, DTC P0132 — O₂ SENSOR CIRCUIT HIGH VOLTAGE (BANK 1 SENSOR 1) —, Diagnostic Trouble Code (DTC) Detecting Criteria.>

CAUTION:

After repair or replacement of faulty parts, conduct Clear Memory Mode <Ref. to EN(H4DOTC)-44, OPERATION, Clear Memory Mode.> and Inspection Mode <Ref. to EN(H4DOTC)-36, OPERATION, Inspection Mode.>.

WIRING DIAGRAM:

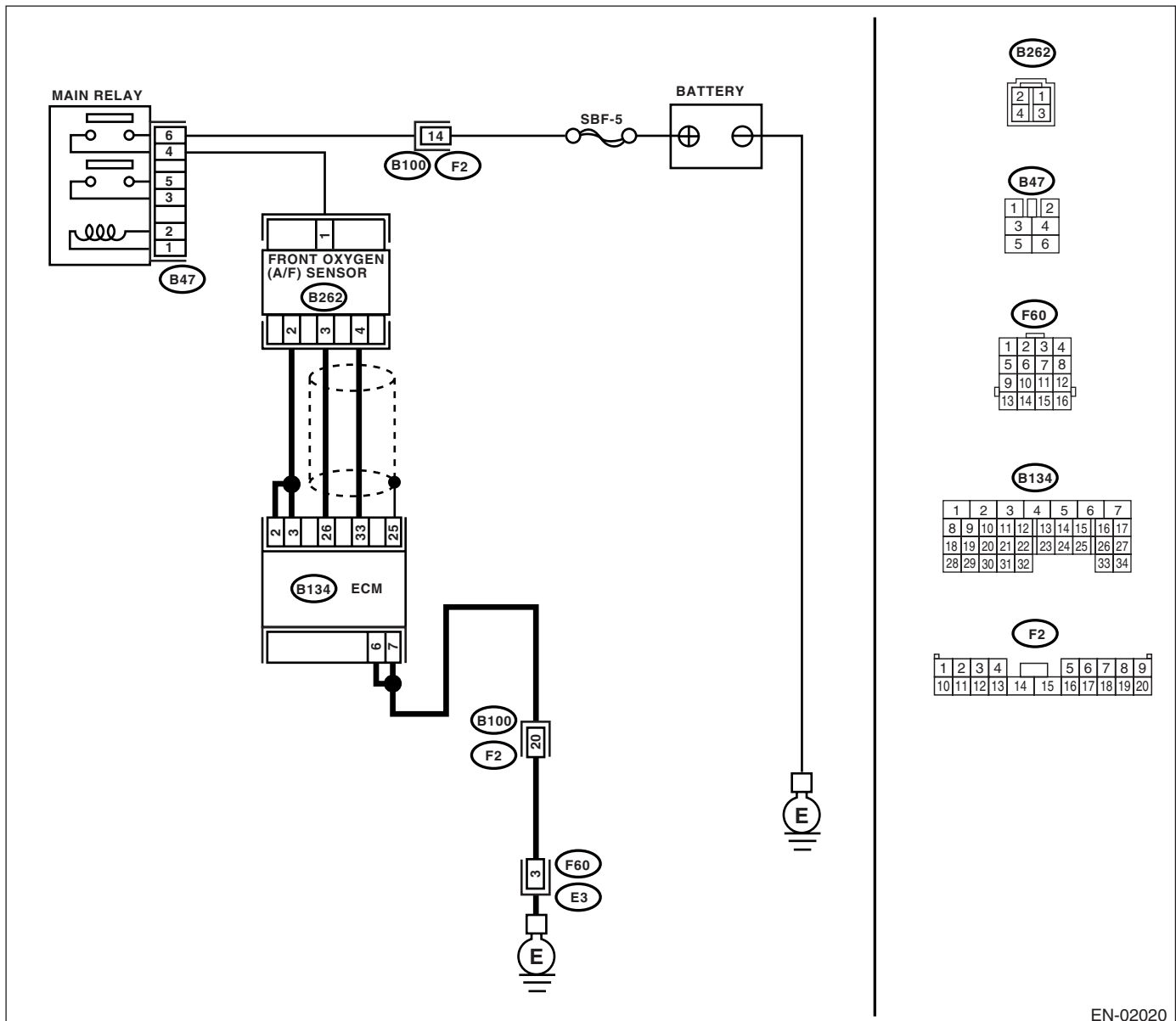

EN-02020

DIAGNOSTIC PROCEDURE WITH DIAGNOSTIC TROUBLE CODE (DTC)

ENGINE (DIAGNOSTICS)

Step	Check	Yes	No
<p>1 CHECK HARNESS BETWEEN ECM AND FRONT OXYGEN (A/F) SENSOR CONNECTOR.</p> <p>1) Turn the ignition switch to ON. 2) Disconnect the connectors from front oxygen (A/F) sensor. 3) Measure the voltage of harness between ECM connector and chassis ground.</p> <p>Connector & terminal (B134) No. 26 (+) — Chassis ground (-): (B134) No. 33 (+) — Chassis ground (-):</p>	Is the voltage more than 8 V?	Replace the front oxygen (A/F) sensor. <Ref. to FU(H4DOTC)-37, Front Oxygen (A/F) Sensor.>	Repair battery short circuit in harness between ECM and front oxygen (A/F) sensor connector.

Z: DTC P0133 — O₂ SENSOR CIRCUIT SLOW RESPONSE (BANK 1 SENSOR 1)

DTC DETECTING CONDITION:

- Two consecutive driving cycles with fault
- GENERAL DESCRIPTION <Ref. to GD(H4DOTC)-58, DTC P0133 — O₂ SENSOR CIRCUIT SLOW RESPONSE (BANK 1 SENSOR 1) —, Diagnostic Trouble Code (DTC) Detecting Criteria.>

CAUTION:

After repair or replacement of faulty parts, conduct Clear Memory Mode <Ref. to EN(H4DOTC)-44, OPERATION, Clear Memory Mode.> and Inspection Mode <Ref. to EN(H4DOTC)-36, OPERATION, Inspection Mode.>.

WIRING DIAGRAM:

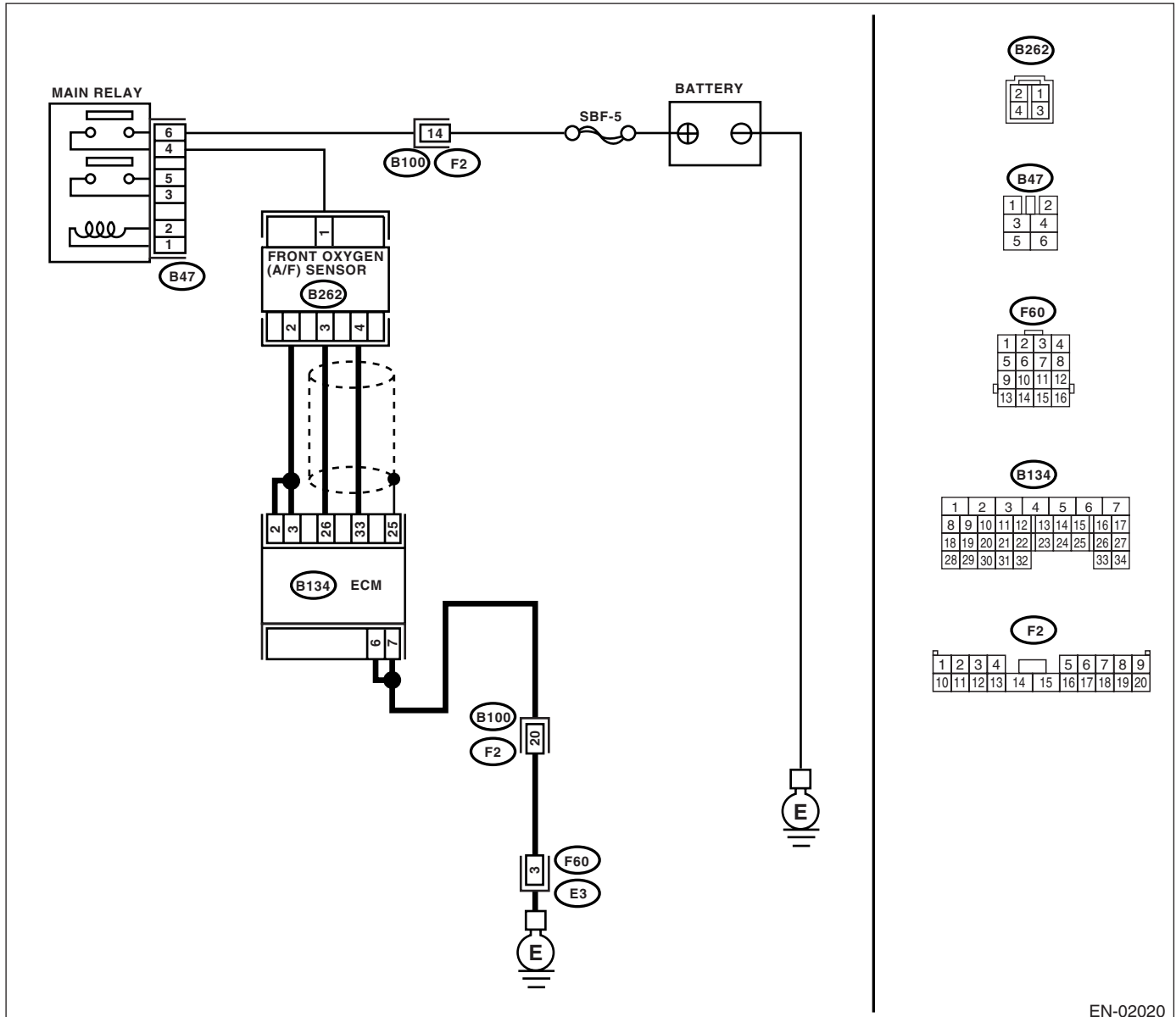

EN-02020

DIAGNOSTIC PROCEDURE WITH DIAGNOSTIC TROUBLE CODE (DTC)

ENGINE (DIAGNOSTICS)

Step	Check	Yes	No
1 CHECK ANY OTHER DTC ON DISPLAY.	Is any other DTC displayed?	Inspect the relevant DTC using "List of Diagnostic Trouble Code (DTC)". <Ref. to EN(H4DOTC)-68, List of Diagnostic Trouble Code (DTC).> NOTE: In this case, it is not necessary to inspect DTC P0133.	Go to step 2.
2 CHECK EXHAUST SYSTEM. NOTE: Check the following items. <ul style="list-style-type: none">• Loose installation of front portion of exhaust pipe onto cylinder heads• Loose connection between front exhaust pipe and front catalytic converter• Damage of exhaust pipe resulting in a hole	Is there a fault in exhaust system?	Repair the exhaust system.	Replace the front oxygen (A/F) sensor. <Ref. to FU(H4DOTC)-37, Front Oxygen (A/F) Sensor.>

DIAGNOSTIC PROCEDURE WITH DIAGNOSTIC TROUBLE CODE (DTC)

ENGINE (DIAGNOSTICS)

AA: DTC P0134 — O₂ SENSOR CIRCUIT NO ACTIVITY DETECTED (BANK 1 SENSOR 1) —

DTC DETECTING CONDITION:

- Immediately at fault recognition
- GENERAL DESCRIPTION <Ref. to GD(H4DOTC)-61, DTC P0134 — O₂ SENSOR CIRCUIT NO ACTIVITY DETECTED (BANK 1 SENSOR 1) —, Diagnostic Trouble Code (DTC) Detecting Criteria.>

CAUTION:

After repair or replacement of faulty parts, conduct Clear Memory Mode <Ref. to EN(H4DOTC)-44, OPERATION, Clear Memory Mode.> and Inspection Mode <Ref. to EN(H4DOTC)-36, OPERATION, Inspection Mode.>.

WIRING DIAGRAM:

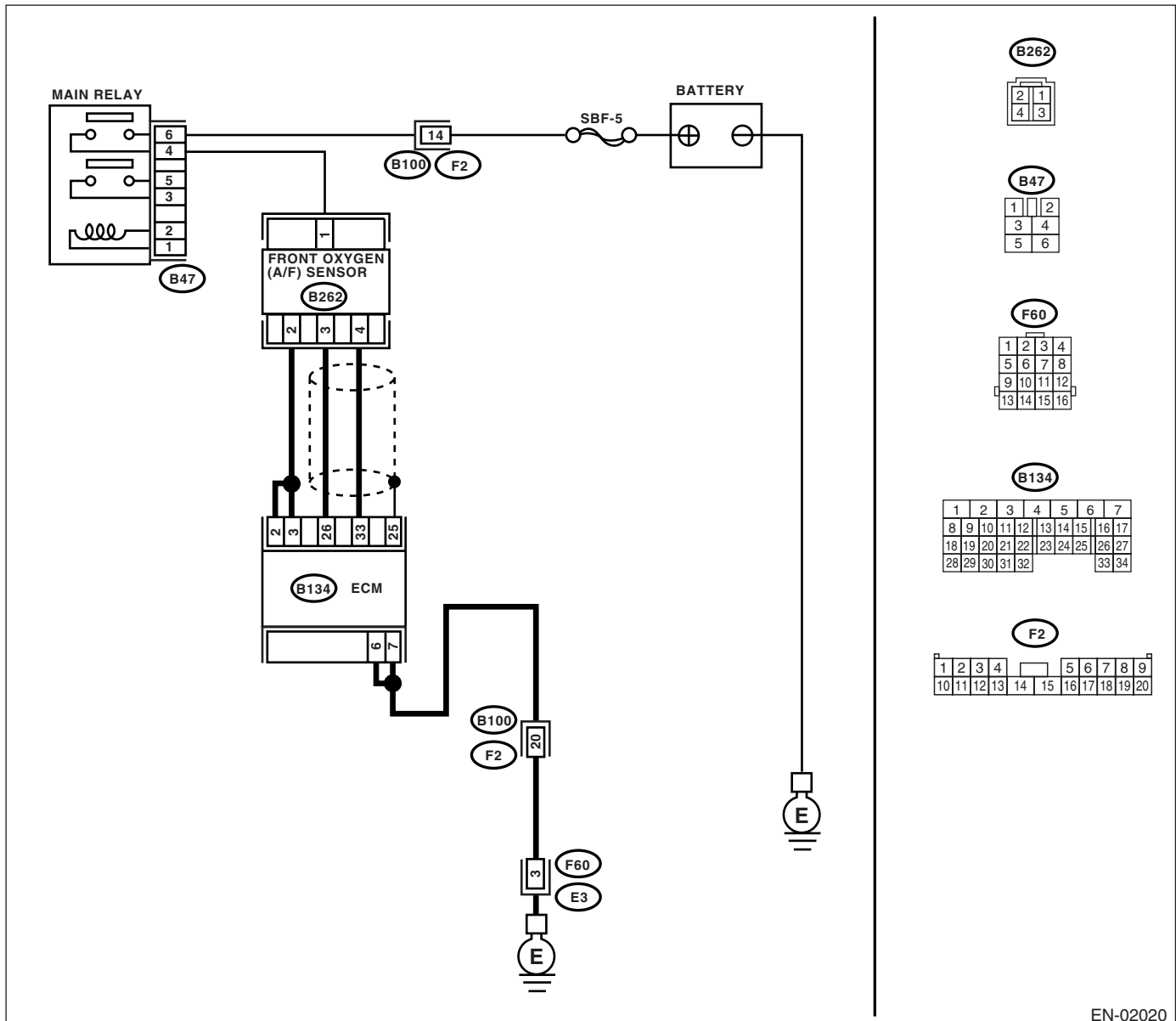

EN-02020

DIAGNOSTIC PROCEDURE WITH DIAGNOSTIC TROUBLE CODE (DTC)

ENGINE (DIAGNOSTICS)

	Step	Check	Yes	No
1	<p>CHECK HARNESS BETWEEN ECM AND FRONT OXYGEN (A/F) SENSOR CONNECTOR.</p> <p>1) Turn the ignition switch to OFF. 2) Disconnect the connectors from ECM and front oxygen (A/F) sensor connector. 3) Measure the resistance of harness between ECM and front oxygen (A/F) sensor connector.</p> <p>Connector & terminal (B134) No. 26 — (B262) No. 3: (B134) No. 33 — (B262) No. 4:</p>	Is the resistance less than 1 Ω ?	Replace the front oxygen (A/F) sensor. <Ref. to FU(H4DOTC)-37, Front Oxygen (A/F) Sensor.>	Repair open circuit in harness between ECM and front oxygen (A/F) sensor connector.

AB:DTC P0137 — O₂ SENSOR CIRCUIT LOW VOLTAGE (BANK 1 SENSOR 2) — DTC DETECTING CONDITION:

- Two consecutive driving cycles with fault
- GENERAL DESCRIPTION <Ref. to GD(H4DOTC)-63, DTC P0137 — O₂ SENSOR CIRCUIT LOW VOLTAGE (BANK 1 SENSOR 2) —, Diagnostic Trouble Code (DTC) Detecting Criteria.>

CAUTION:

After repair or replacement of faulty parts, conduct Clear Memory Mode <Ref. to EN(H4DOTC)-44, OPERATION, Clear Memory Mode.> and Inspection Mode <Ref. to EN(H4DOTC)-36, OPERATION, Inspection Mode.>.

WIRING DIAGRAM:

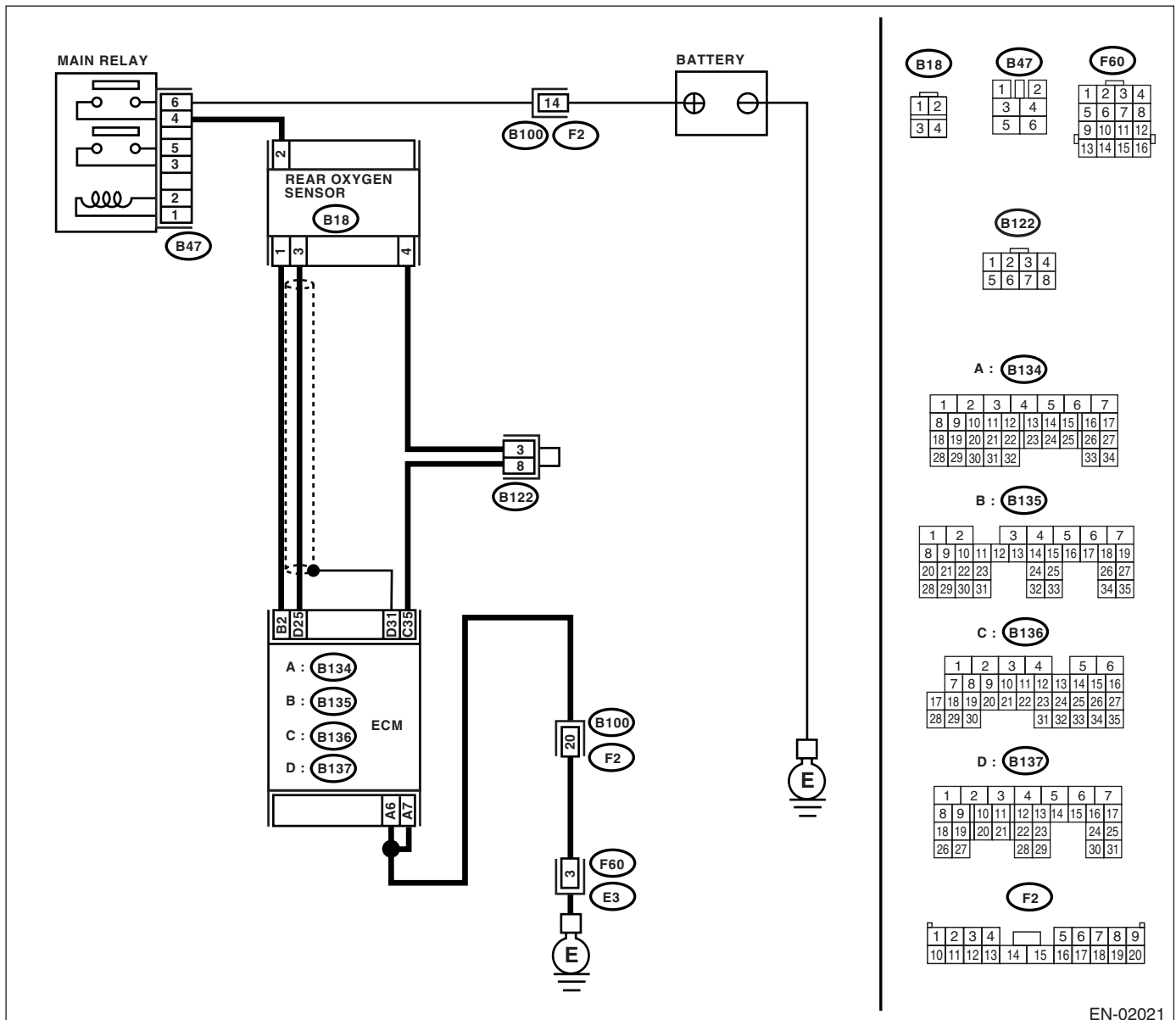

EN-02021

DIAGNOSTIC PROCEDURE WITH DIAGNOSTIC TROUBLE CODE (DTC)

ENGINE (DIAGNOSTICS)

Step	Check	Yes	No
1 CHECK ANY OTHER DTC ON DISPLAY.	Is any other DTC displayed?	Using the List of Diagnostic Trouble Code (DTC), check the appropriate DTC. <Ref. to EN(H4DOTC)-68, List of Diagnostic Trouble Code (DTC).>	Go to step 2.
2 CHECK REAR OXYGEN SENSOR DATA. 1) Warm-up the engine until engine coolant temperature is above 70°C (158°F), and keep the engine speed at 2,000 rpm to 3,000 rpm for 2 minutes. 2) Read the data of rear oxygen sensor signal using Subaru Select Monitor or OBD-II general scan tool. NOTE: <ul style="list-style-type: none"> • Subaru Select Monitor For detailed operation procedure, refer to the "READ CURRENT DATA SHOWN ON DISPLAY FOR ENGINE". <Ref. to EN(H4DOTC)-29, Subaru Select Monitor.> <ul style="list-style-type: none"> • OBD-II general scan tool For detailed operation procedures, refer to the OBD-II General Scan Tool Instruction Manual.	Does the value fluctuate?	Go to step 6.	Go to step 3.
3 CHECK REAR OXYGEN SENSOR DATA. Read the data of rear oxygen sensor signal using Subaru Select Monitor or OBD-II general scan tool.	Is the voltage 0.2 — 0.4 V?	Go to step 4.	Replace the rear oxygen sensor. <Ref. to FU(H4DOTC)-39, Rear Oxygen Sensor.>
4 CHECK HARNESS BETWEEN ECM AND REAR OXYGEN SENSOR CONNECTOR. 1) Turn the ignition switch to OFF. 2) Disconnect the connectors from ECM and rear oxygen sensor. 3) Measure the resistance of harness between ECM and rear oxygen sensor connector. Connector & terminal (B137) No. 25 — (B18) No. 3:	Is the resistance more than 3 Ω?	Repair the open circuit in harness between ECM and rear oxygen sensor connector.	Go to step 5.
5 CHECK HARNESS BETWEEN REAR OXYGEN SENSOR AND ECM CONNECTOR. 1) Turn the ignition switch to OFF. 2) Disconnect the connector from rear oxygen sensor. 3) Turn the ignition switch to ON. 4) Measure the voltage between rear oxygen sensor harness connector and engine ground or chassis ground. Connector & terminal (B18) No. 3 (+) — Engine ground (-):	Is the voltage more than 0.2 V?	Replace the rear oxygen sensor. <Ref. to FU(H4DOTC)-39, Rear Oxygen Sensor.>	Repair the harness and connector. NOTE: In this case, repair the following: <ul style="list-style-type: none"> • Open circuit in harness between rear oxygen sensor and ECM connector • Poor contact in rear oxygen sensor connector • Poor contact in ECM connector

DIAGNOSTIC PROCEDURE WITH DIAGNOSTIC TROUBLE CODE (DTC)

ENGINE (DIAGNOSTICS)

Step	Check	Yes	No
6 CHECK EXHAUST SYSTEM. Check the exhaust system parts. NOTE: Check the following items. <ul style="list-style-type: none">• Loose installation of portions• Damage (crack, hole etc.) of parts• Looseness and ill fitting of parts between front oxygen (A/F) sensor and rear oxygen sensor	Is there a fault in exhaust system?	Repair or replace the faulty parts.	Replace the rear oxygen sensor. <Ref. to FU(H4DOTC)-39, Rear Oxygen Sensor.>

DIAGNOSTIC PROCEDURE WITH DIAGNOSTIC TROUBLE CODE (DTC)

ENGINE (DIAGNOSTICS)

AC:DTC P0138 — O₂ SENSOR CIRCUIT HIGH VOLTAGE (BANK 1 SENSOR 2) — DTC DETECTING CONDITION:

- Two consecutive driving cycles with fault
- GENERAL DESCRIPTION <Ref. to GD(H4DOTC)-65, DTC P0138 — O₂ SENSOR CIRCUIT HIGH VOLTAGE (BANK 1 SENSOR 2) —, Diagnostic Trouble Code (DTC) Detecting Criteria.>

CAUTION:

After repair or replacement of faulty parts, conduct Clear Memory Mode <Ref. to EN(H4DOTC)-44, OPERATION, Clear Memory Mode.> and Inspection Mode <Ref. to EN(H4DOTC)-36, OPERATION, Inspection Mode.>.

WIRING DIAGRAM:

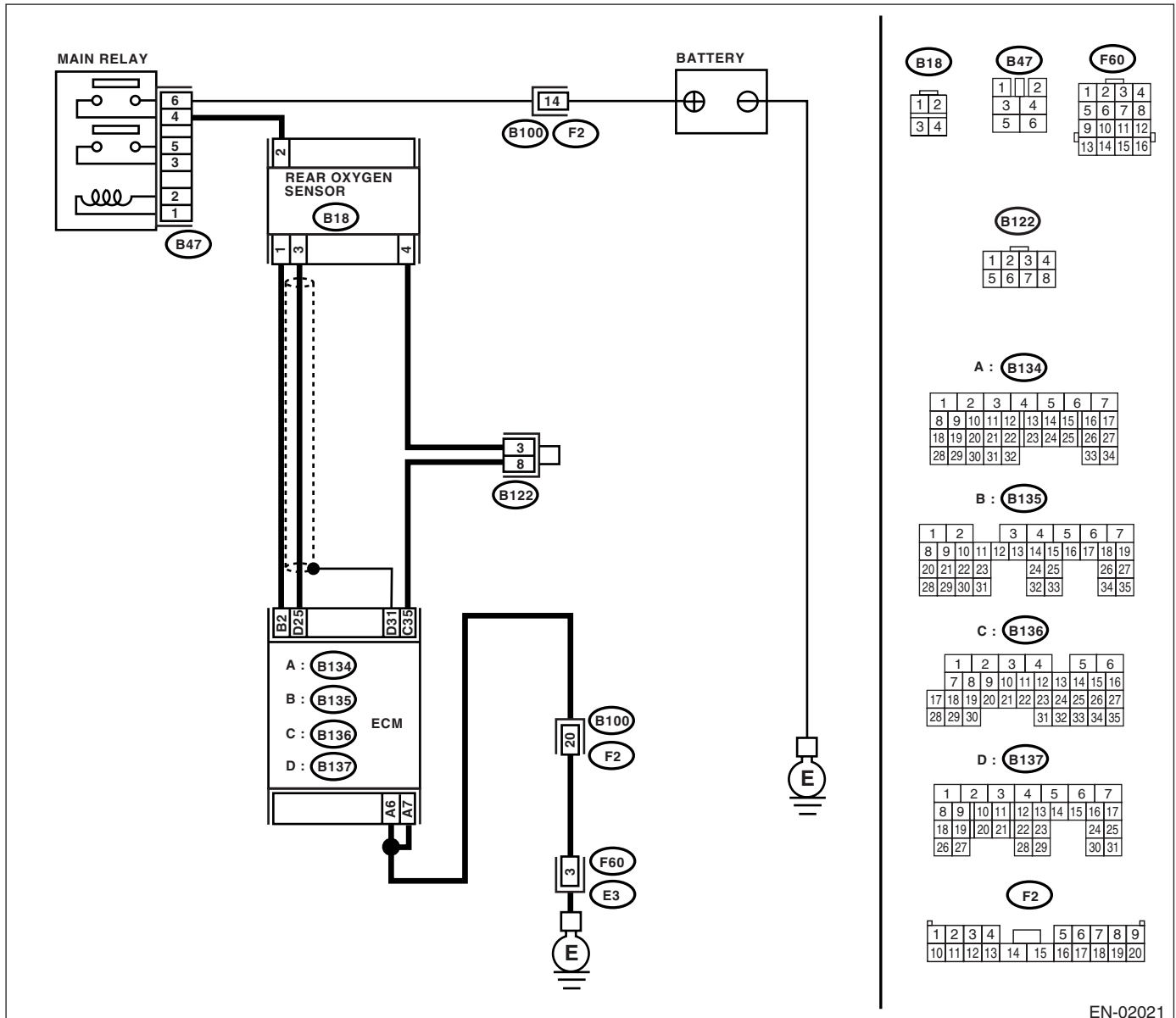

EN-02021

DIAGNOSTIC PROCEDURE WITH DIAGNOSTIC TROUBLE CODE (DTC)

ENGINE (DIAGNOSTICS)

Step	Check	Yes	No
1 CHECK ANY OTHER DTC ON DISPLAY.	Is any other DTC displayed?	Using the List of Diagnostic Trouble Code (DTC), check the appropriate DTC. <Ref. to EN(H4DOTC)-68, List of Diagnostic Trouble Code (DTC).>	Go to step 2.
2 CHECK REAR OXYGEN SENSOR DATA. 1) Warm-up the engine until engine coolant temperature is above 70°C (158°F), and keep the engine speed at 2,000 rpm to 3,000 rpm for 2 minutes. 2) Read the data of rear oxygen sensor signal using Subaru Select Monitor or OBD-II general scan tool. NOTE: <ul style="list-style-type: none"> • Subaru Select Monitor For detailed operation procedure, refer to the "READ CURRENT DATA SHOWN ON DISPLAY FOR ENGINE". <Ref. to EN(H4DOTC)-29, Subaru Select Monitor.> <ul style="list-style-type: none"> • OBD-II general scan tool For detailed operation procedures, refer to the OBD-II General Scan Tool Instruction Manual.	Does the value fluctuate?	Go to step 6.	Go to step 3.
3 CHECK REAR OXYGEN SENSOR DATA. Read the data of rear oxygen sensor signal using Subaru Select Monitor or OBD-II general scan tool.	Is the voltage 0.2 — 0.4 V?	Go to step 4.	Replace the rear oxygen sensor. <Ref. to FU(H4DOTC)-39, Rear Oxygen Sensor.>
4 CHECK HARNESS BETWEEN ECM AND REAR OXYGEN SENSOR CONNECTOR. 1) Turn the ignition switch to OFF. 2) Disconnect the connectors from ECM and rear oxygen sensor. 3) Measure the resistance of harness between ECM and rear oxygen sensor connector. Connector & terminal (B137) No. 25 — (B18) No. 3:	Is the resistance more than 3 Ω?	Repair the open circuit in harness between ECM and rear oxygen sensor connector.	Go to step 5.
5 CHECK HARNESS BETWEEN REAR OXYGEN SENSOR AND ECM CONNECTOR. 1) Turn the ignition switch to OFF. 2) Disconnect the connector from rear oxygen sensor. 3) Turn the ignition switch to ON. 4) Measure the voltage between rear oxygen sensor harness connector and engine ground or chassis ground. Connector & terminal (B18) No. 3 (+) — Engine ground (-):	Is the voltage more than 0.2 V?	Replace the rear oxygen sensor. <Ref. to FU(H4DOTC)-39, Rear Oxygen Sensor.>	Repair the harness and connector. NOTE: In this case, repair the following: <ul style="list-style-type: none"> • Open circuit in harness between rear oxygen sensor and ECM connector • Poor contact in rear oxygen sensor connector • Poor contact in ECM connector

DIAGNOSTIC PROCEDURE WITH DIAGNOSTIC TROUBLE CODE (DTC)

ENGINE (DIAGNOSTICS)

Step	Check	Yes	No
6 CHECK EXHAUST SYSTEM. Check the exhaust system parts. NOTE: Check the following items. <ul style="list-style-type: none">• Loose installation of portions• Damage (crack, hole etc.) of parts• Looseness and ill fitting of parts between front oxygen (A/F) sensor and rear oxygen sensor	Is there a fault in exhaust system?	Repair or replace the faulty parts.	Replace the rear oxygen sensor. <Ref. to FU(H4DOTC)-39, Rear Oxygen Sensor.>

DIAGNOSTIC PROCEDURE WITH DIAGNOSTIC TROUBLE CODE (DTC)

ENGINE (DIAGNOSTICS)

AD:DTC P0139 — O₂ SENSOR CIRCUIT SLOW RESPONSE (BANK 1 SENSOR 2)

DTC DETECTING CONDITION:

- Two consecutive driving cycles with fault
- GENERAL DESCRIPTION <Ref. to GD(H4DOTC)-67, DTC P0139 — O₂ SENSOR CIRCUIT SLOW RESPONSE (BANK 1 SENSOR 2) —, Diagnostic Trouble Code (DTC) Detecting Criteria.>

CAUTION:

After repair or replacement of faulty parts, conduct Clear Memory Mode <Ref. to EN(H4DOTC)-44, OPERATION, Clear Memory Mode.> and Inspection Mode <Ref. to EN(H4DOTC)-36, OPERATION, Inspection Mode.>.

WIRING DIAGRAM:

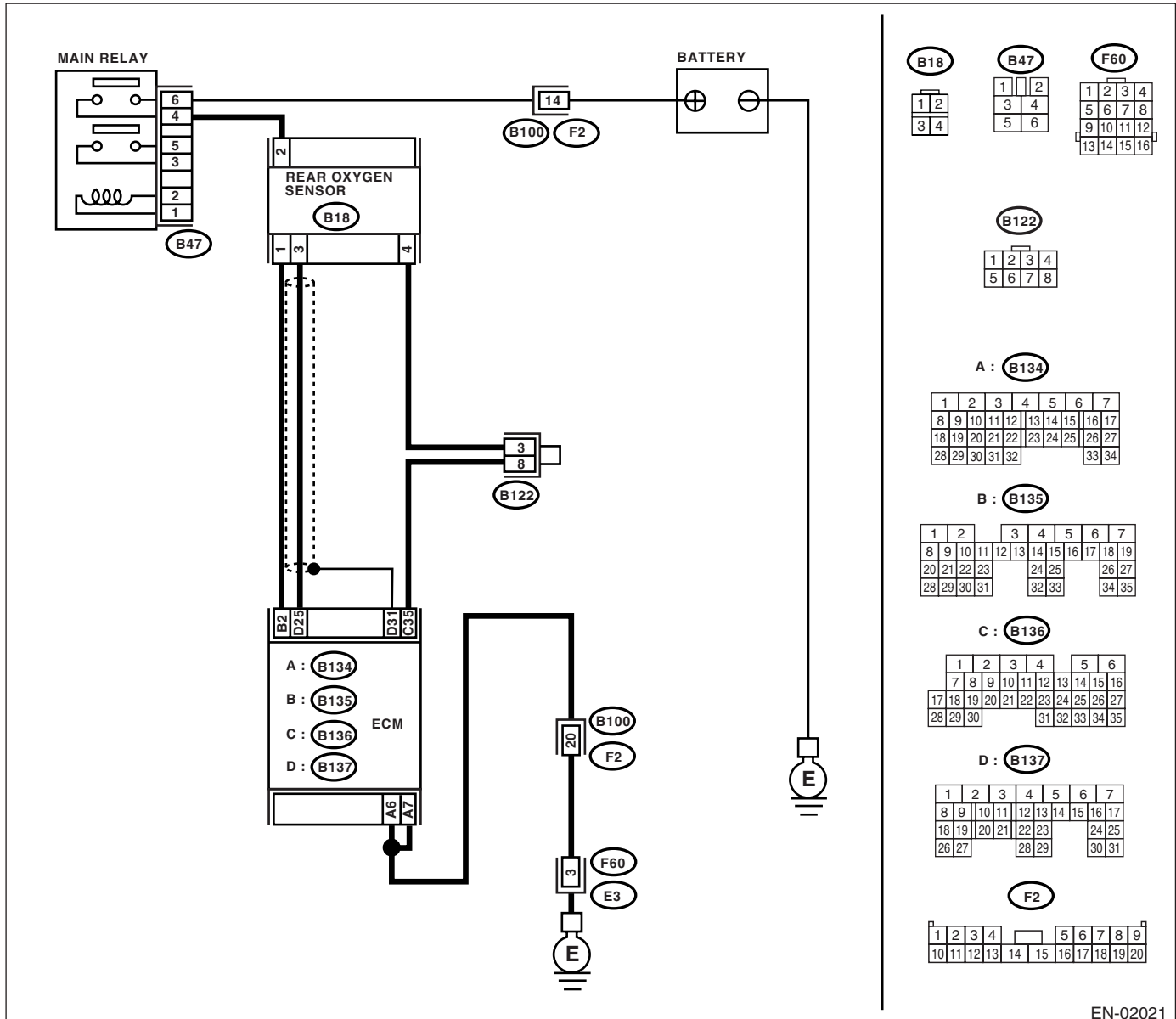

EN-02021

DIAGNOSTIC PROCEDURE WITH DIAGNOSTIC TROUBLE CODE (DTC)

ENGINE (DIAGNOSTICS)

Step	Check	Yes	No
1 CHECK ANY OTHER DTC ON DISPLAY.	Is any other DTC displayed?	Inspect the relevant DTC using "List of Diagnostic Trouble Code (DTC)". <Ref. to EN(H4DOTC)-68, List of Diagnostic Trouble Code (DTC).> NOTE: In this case, it is not necessary to inspect DTC P0139.	Replace the rear oxygen sensor. <Ref. to FU(H4DOTC)-39, Rear Oxygen Sensor.>

AE:DTC P0171 — SYSTEM TOO LEAN (BANK 1) —

NOTE:

For the diagnostic procedure, refer to DTC P0172. <Ref. to EN(H4DOTC)-142, DTC P0172 — SYSTEM TOO RICH (BANK 1) —, Diagnostic Procedure with Diagnostic Trouble Code (DTC).>

DIAGNOSTIC PROCEDURE WITH DIAGNOSTIC TROUBLE CODE (DTC)

ENGINE (DIAGNOSTICS)

AF:DTC P0172 — SYSTEM TOO RICH (BANK 1) —

DTC DETECTING CONDITION:

- Two consecutive driving cycles with fault
- GENERAL DESCRIPTION <Ref. to GD(H4DOTC)-70, DTC P0171 — SYSTEM TOO LEAN (BANK 1) — , Diagnostic Trouble Code (DTC) Detecting Criteria.> <Ref. to GD(H4DOTC)-73, DTC P0172 — SYSTEM TOO RICH (BANK 1) —, Diagnostic Trouble Code (DTC) Detecting Criteria.>

TROUBLE SYMPTOM:

- Erroneous idling
- Engine stalls.
- Poor driving performance

CAUTION:

After repair or replacement of faulty parts, conduct Clear Memory Mode <Ref. to EN(H4DOTC)-44, OPERATION, Clear Memory Mode.> and Inspection Mode <Ref. to EN(H4DOTC)-36, OPERATION, Inspection Mode.>.

Step	Check	Yes	No
1 CHECK EXHAUST SYSTEM.	Are there holes or loose bolts on exhaust system?	Repair the exhaust system.	Go to step 2.
2 CHECK AIR INTAKE SYSTEM.	Are there holes, loose bolts or disconnection of hose on air intake system?	Repair the air intake system.	Go to step 3.
3 CHECK FUEL PRESSURE. Warning: • Place “NO FIRE” signs near the working area. • Be careful not to spill fuel on the floor. 1) Release the fuel pressure. (1) Disconnect the connector from fuel pump relay. (2) Start the engine and run it until it stalls. (3) After the engine stalls, crank it for 5 more seconds. (4) Turn the ignition switch to OFF. 2) Connect the connector to fuel pump relay. 3) Disconnect the fuel delivery hose from fuel filter, and connect fuel pressure gauge. 4) Install the fuel filler cap. 5) Start the engine and idle while gear position is neutral. 6) Measure the fuel pressure while disconnecting pressure regulator vacuum hose from intake manifold. Warning: Before removing the fuel pressure gauge, release fuel pressure. NOTE: If the fuel pressure does not increase, squeeze fuel return hose 2 to 3 times, then measure fuel pressure again.	Is the measured value 284 — 314 kPa (2.9 — 3.2 kg/cm ² , 41 — 46 psi)?	Go to step 4.	Repair the following items. Fuel pressure too high: • Clogged fuel return line or bent hose Fuel pressure too low: • Improper fuel pump discharge • Clogged fuel supply line

DIAGNOSTIC PROCEDURE WITH DIAGNOSTIC TROUBLE CODE (DTC)

ENGINE (DIAGNOSTICS)

Step	Check	Yes	No
<p>4</p> <p>CHECK FUEL PRESSURE. After connecting the pressure regulator vacuum hose, measure fuel pressure.</p> <p>Warning: Before removing the fuel pressure gauge, release fuel pressure.</p> <p>NOTE:</p> <ul style="list-style-type: none"> • If the fuel pressure does not increase, squeeze fuel return hose 2 to 3 times, then measure fuel pressure again. • If out of specification as measured at this step, check or replace the pressure regulator and pressure regulator vacuum hose. 	<p>Is the measured value 206 — 235 kPa (2.1 — 2.4 kg/cm², 30 — 34 psi)?</p>	<p>Go to step 5.</p>	<p>Repair the following items.</p> <p>Fuel pressure too high:</p> <ul style="list-style-type: none"> • Faulty pressure regulator • Clogged fuel return line or bent hose <p>Fuel pressure too low:</p> <ul style="list-style-type: none"> • Faulty pressure regulator • Improper fuel pump discharge • Clogged fuel supply line
<p>5</p> <p>CHECK ENGINE COOLANT TEMPERATURE SENSOR.</p> <ol style="list-style-type: none"> 1) Start the engine and warm-up completely. 2) Read the data of engine coolant temperature sensor signal using Subaru Select Monitor or OBD-II general scan tool. <p>NOTE:</p> <ul style="list-style-type: none"> • Subaru Select Monitor <p>For detailed operation procedure, refer to the "READ CURRENT DATA FOR ENGINE". <Ref. to EN(H4DOTC)-29, Subaru Select Monitor.></p> <ul style="list-style-type: none"> • OBD-II general scan tool <p>For detailed operation procedures, refer to the OBD-II General Scan Tool Instruction Manual.</p>	<p>Is the temperature more than 60°C (140°F)?</p>	<p>Go to step 6.</p>	<p>Replace the engine coolant temperature sensor. <Ref. to FU(H4DOTC)-26, Engine Coolant Temperature Sensor.></p>
<p>6</p> <p>CHECK MASS AIR FLOW AND INTAKE AIR TEMPERATURE.</p> <ol style="list-style-type: none"> 1) Start the engine and warm-up engine until coolant temperature is greater than 60°C (140°F). 2) Place the shift lever in neutral position. 3) Turn the A/C switch to OFF. 4) Turn all accessory switches to OFF. 5) Read the data of mass air flow and intake air temperature sensor signal using Subaru Select Monitor or OBD-II general scan tool. <p>NOTE:</p> <ul style="list-style-type: none"> • Subaru Select Monitor <p>For detailed operation procedure, refer to the "READ CURRENT DATA FOR ENGINE". <Ref. to EN(H4DOTC)-29, Subaru Select Monitor.></p> <ul style="list-style-type: none"> • OBD-II general scan tool <p>For detailed operation procedure, refer to the OBD-II General Scan Tool Instruction Manual.</p>	<p>Is the measured value within the followings? Ignition ON: 73.3 — 106.6 kPa (550 — 800 mmHg, 21.65 — 31.50 inHg) Idling: 24.0 — 41.3 kPa (180 — 310 mmHg, 7.09 — 12.20 inHg)</p>	<p>Go to step 7.</p>	<p>Replace the mass air flow and intake air temperature sensor. <Ref. to FU(H4DOTC)-30, Mass Air Flow and Intake Air Temperature Sensor.></p>

DIAGNOSTIC PROCEDURE WITH DIAGNOSTIC TROUBLE CODE (DTC)

ENGINE (DIAGNOSTICS)

Step	Check	Yes	No
<p>7 CHECK MASS AIR FLOW AND INTAKE AIR TEMPERATURE SENSOR.</p> <p>1) Start the engine and warm-up engine until coolant temperature is greater than 60°C (140°F).</p> <p>2) Place the shift lever in neutral position.</p> <p>3) Turn the A/C switch to OFF.</p> <p>4) Turn all accessory switches to OFF.</p> <p>5) Open the front hood.</p> <p>6) Measure the ambient temperature.</p> <p>7) Read the data of mass air flow and intake air temperature sensor signal using Subaru Select Monitor or OBD-II general scan tool.</p> <p>NOTE:</p> <ul style="list-style-type: none">• Subaru Select Monitor <p>For detailed operation procedure, refer to the "READ CURRENT DATA FOR ENGINE". <Ref. to EN(H4DOTC)-29, Subaru Select Monitor.></p> <ul style="list-style-type: none">• OBD-II general scan tool <p>For detailed operation procedure, refer to the OBD-II General Scan Tool Instruction Manual.</p>	<p>Subtract ambient temperature from intake air temperature. Is the obtained value -10 — 50°C (14 — 122°F)?</p>	<p>Contact your SOA Service Center.</p> <p>NOTE: Inspection by DTM is required, because probable cause is deterioration of multiple parts.</p>	<p>Check the mass air flow and intake air temperature sensor. <Ref. to FU(H4DOTC)-30, Mass Air Flow and Intake Air Temperature Sensor.></p>

AG:DTC P0181 — FUEL TEMPERATURE SENSOR “A” CIRCUIT RANGE/PERFORMANCE —

DTC DETECTING CONDITION:

- Two consecutive driving cycles with fault
- GENERAL DESCRIPTION <Ref. to GD(H4DOTC)-76, DTC P0181 — FUEL TEMPERATURE SENSOR “A” CIRCUIT RANGE/PERFORMANCE —, Diagnostic Trouble Code (DTC) Detecting Criteria.>

CAUTION:

After repair or replacement of faulty parts, conduct Clear Memory Mode <Ref. to EN(H4DOTC)-44, OPERATION, Clear Memory Mode.> and Inspection Mode <Ref. to EN(H4DOTC)-36, OPERATION, Inspection Mode.>.

WIRING DIAGRAM:

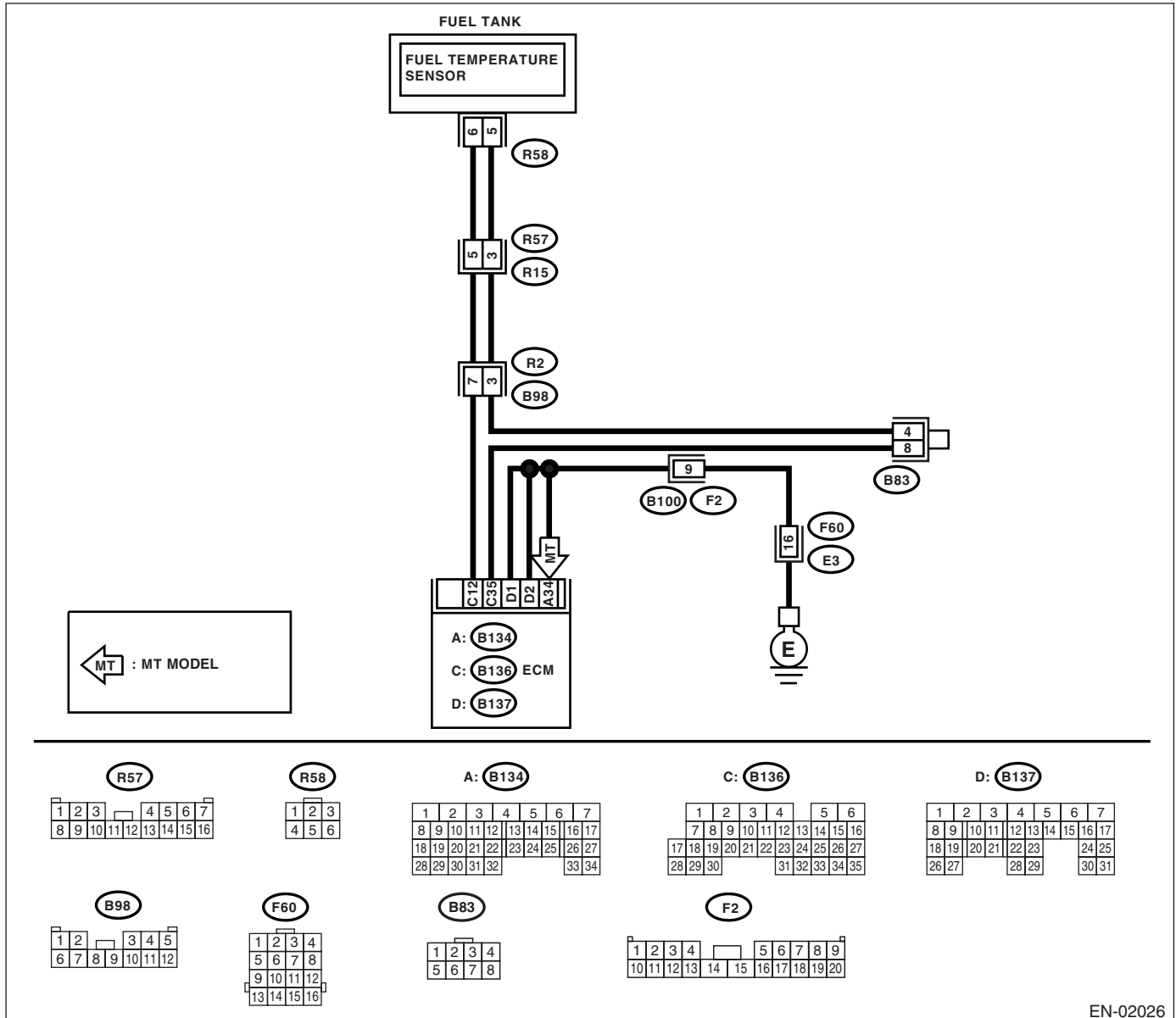

EN-02026

DIAGNOSTIC PROCEDURE WITH DIAGNOSTIC TROUBLE CODE (DTC)

ENGINE (DIAGNOSTICS)

Step	Check	Yes	No
1 CHECK FOR OTHER DTC ON DISPLAY.	Is any other DTC displayed?	Inspect the relevant DTC using "List of Diagnostic Trouble Codes (DTC)". <Ref. to EN(H4DOTC)-68, List of Diagnostic Trouble Code (DTC).> NOTE: In this case, it is not necessary to inspect DTC P0181.	Replace the fuel temperature sensor. <Ref. to EC(H4DOTC)-9, Fuel Temperature Sensor.>

AH:DTC P0182 — FUEL TEMPERATURE SENSOR “A” CIRCUIT LOW INPUT — DTC DETECTING CONDITION:

- Immediately at fault recognition
- GENERAL DESCRIPTION <Ref. to GD(H4DOTC)-79, DTC P0182 — FUEL TEMPERATURE SENSOR “A” CIRCUIT LOW INPUT —, Diagnostic Trouble Code (DTC) Detecting Criteria.>

CAUTION:

After repair or replacement of faulty parts, conduct Clear Memory Mode <Ref. to EN(H4DOTC)-44, OPERATION, Clear Memory Mode.> and Inspection Mode <Ref. to EN(H4DOTC)-36, OPERATION, Inspection Mode.>.

WIRING DIAGRAM:

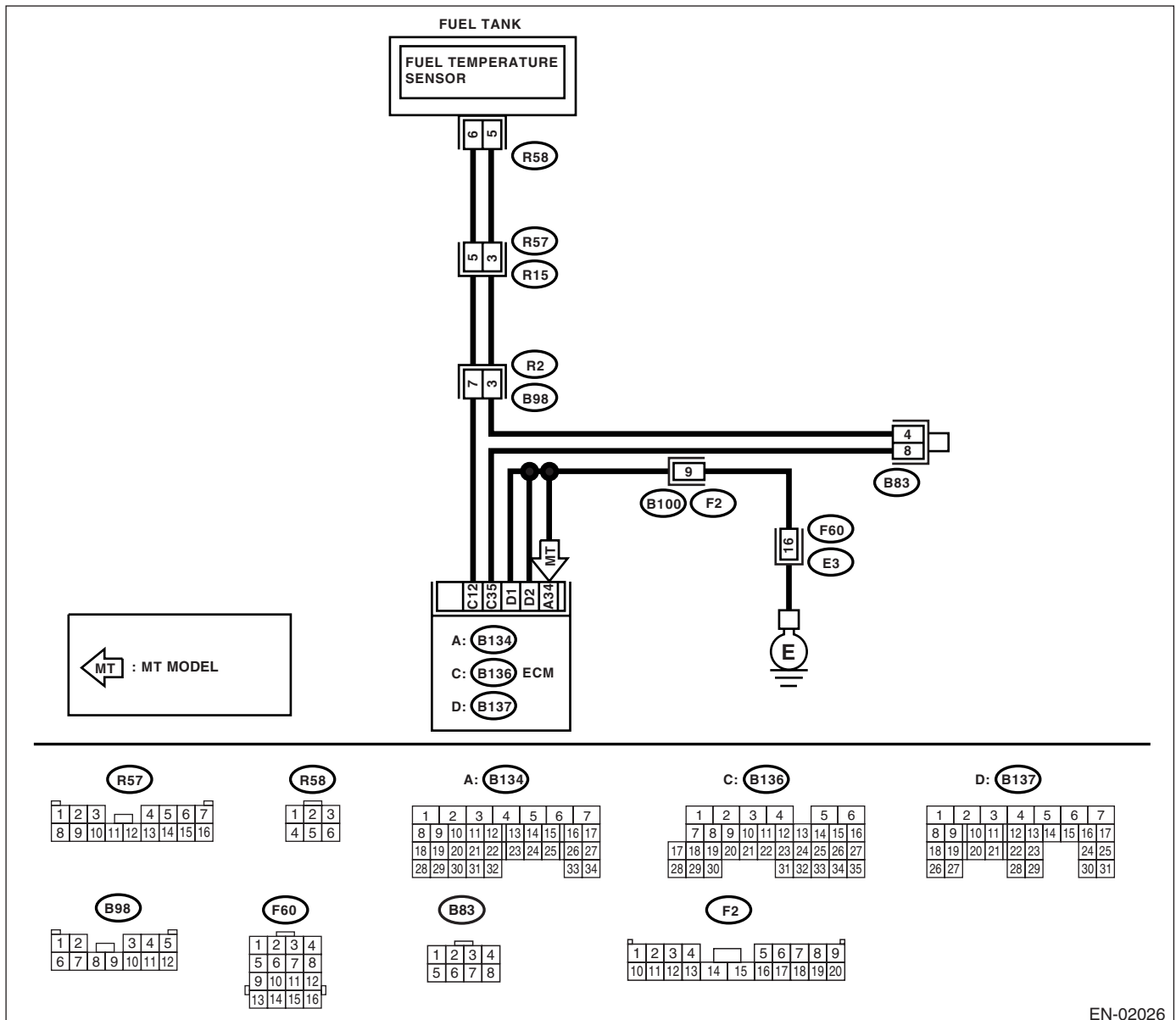

DIAGNOSTIC PROCEDURE WITH DIAGNOSTIC TROUBLE CODE (DTC)

ENGINE (DIAGNOSTICS)

Step	Check	Yes	No
<p>1</p> <p>CHECK CURRENT DATA.</p> <p>1) Start the engine.</p> <p>2) Read the data of fuel temperature sensor signal using Subaru Select Monitor or OBD-II general scan tool.</p> <p>NOTE:</p> <ul style="list-style-type: none">• Subaru Select Monitor <p>For detailed operation procedures, refer to "READ CURRENT DATA FOR ENGINE". <Ref. to EN(H4DOTC)-29, Subaru Select Monitor.></p> <ul style="list-style-type: none">• OBD-II general scan tool <p>For detailed operation procedures, refer to the OBD-II General Scan Tool Instruction Manual.</p>	<p>Is the temperature more than 150°C (302°F)?</p>	<p>Go to step 2.</p>	<p>The malfunction indicator light may light up, however, the circuit is returned to the normal status at the moment.</p>
<p>2</p> <p>CHECK CURRENT DATA.</p> <p>1) Turn ignition switch to OFF.</p> <p>2) Remove the access hole lid.</p> <p>3) Disconnect the connector from fuel pump.</p> <p>4) Turn ignition switch to ON.</p> <p>5) Read the data of fuel temperature sensor signal using Subaru Select Monitor or OBD-II general scan tool.</p> <p>NOTE:</p> <ul style="list-style-type: none">• Subaru Select Monitor <p>For detailed operation procedures, refer to "READ CURRENT DATA FOR ENGINE". <Ref. to EN(H4DOTC)-29, Subaru Select Monitor.></p> <ul style="list-style-type: none">• OBD-II general scan tool <p>For detailed operation procedures, refer to the OBD-II General Scan Tool Instruction Manual.</p>	<p>Is the temperature less than -40°C (-40°F)?</p>	<p>Replace the fuel temperature sensor. <Ref. to EC(H4DOTC)-9, Fuel Temperature Sensor.></p>	<p>Repair short circuit to ground in harness between fuel pump and ECM connector.</p>

DIAGNOSTIC PROCEDURE WITH DIAGNOSTIC TROUBLE CODE (DTC)

ENGINE (DIAGNOSTICS)

AI: DTC P0183 — FUEL TEMPERATURE SENSOR “A” CIRCUIT HIGH INPUT — DTC DETECTING CONDITION:

- Immediately at fault recognition
- GENERAL DESCRIPTION <Ref. to GD(H4DOTC)-81, DTC P0183 — FUEL TEMPERATURE SENSOR “A” CIRCUIT HIGH INPUT —, Diagnostic Trouble Code (DTC) Detecting Criteria.>

CAUTION:

After repair or replacement of faulty parts, conduct Clear Memory Mode <Ref. to EN(H4DOTC)-44, OPERATION, Clear Memory Mode.> and Inspection Mode <Ref. to EN(H4DOTC)-36, OPERATION, Inspection Mode.>.

WIRING DIAGRAM:

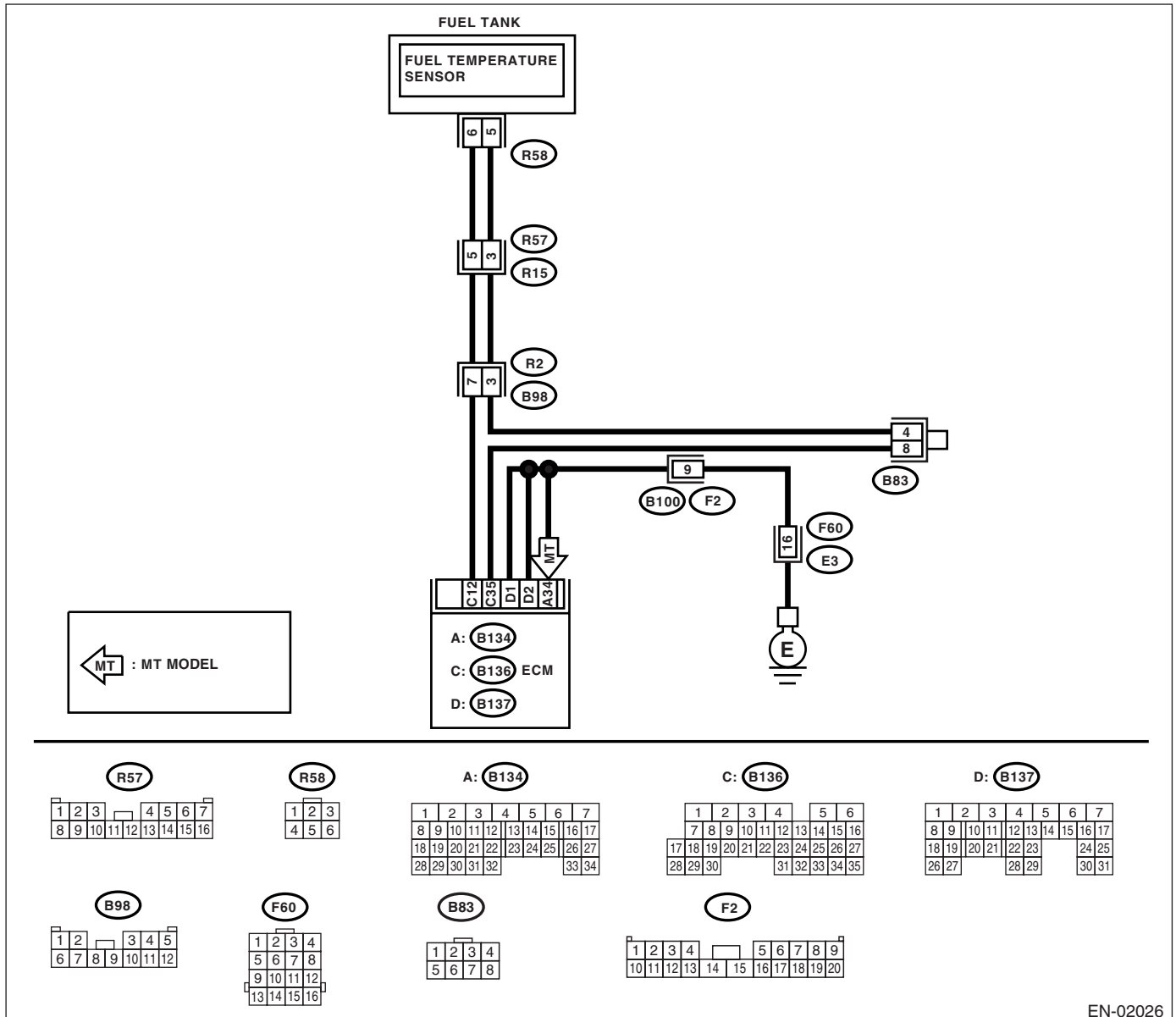

EN-02026

DIAGNOSTIC PROCEDURE WITH DIAGNOSTIC TROUBLE CODE (DTC)

ENGINE (DIAGNOSTICS)

Step	Check	Yes	No
1 CHECK CURRENT DATA. 1) Start the engine. 2) Read the data of fuel temperature sensor signal using Subaru Select Monitor or OBD-II general scan tool. NOTE: <ul style="list-style-type: none"> Subaru Select Monitor For detailed operation procedures, refer to "READ CURRENT DATA FOR ENGINE". <Ref. to EN(H4DOTC)-29, Subaru Select Monitor.> <ul style="list-style-type: none"> OBD-II general scan tool For detailed operation procedures, refer to the OBD-II General Scan Tool Instruction Manual.	Is the temperature less than -40°C (-40°F)?	Go to step 2.	Repair poor contact. NOTE: In this case, repair the following: <ul style="list-style-type: none"> Poor contact in fuel pump connector Poor contact in ECM connector Poor contact in coupling connector Poor contact in joint connector
2 CHECK HARNESS BETWEEN FUEL TEMPERATURE SENSOR AND ECM CONNECTOR. 1) Turn ignition switch to OFF. 2) Remove the access hole lid. 3) Disconnect the connector from fuel pump. 4) Measure the voltage between fuel pump connector and chassis ground. Connector & terminal (R58) No. 6 (+) — Chassis ground (-):	Is the voltage more than 10 V?	Repair short circuit to battery in harness between ECM and fuel pump connector.	Go to step 3.
3 CHECK HARNESS BETWEEN FUEL TEMPERATURE SENSOR AND ECM CONNECTOR. 1) Turn ignition switch to ON. 2) Measure the voltage between fuel pump connector and chassis ground. Connector & terminal (R58) No. 6 (+) — Chassis ground (-):	Is the voltage more than 10 V?	Repair short circuit to battery in harness between ECM and fuel pump connector.	Go to step 4.
4 CHECK HARNESS BETWEEN FUEL TEMPERATURE SENSOR AND ECM CONNECTOR. Measure the voltage between fuel pump connector and chassis ground. Connector & terminal (R58) No. 6 (+) — Chassis ground (-):	Is the voltage more than 4 V?	Go to step 5.	Repair harness and connector. NOTE: In this case, repair the following: <ul style="list-style-type: none"> Open circuit in harness between ECM and fuel pump connector Poor contact in fuel pump connector Poor contact in ECM connector Poor contact in coupling connector

DIAGNOSTIC PROCEDURE WITH DIAGNOSTIC TROUBLE CODE (DTC)

ENGINE (DIAGNOSTICS)

Step	Check	Yes	No
<p>5 CHECK HARNESS BETWEEN FUEL TEMPERATURE SENSOR AND ECM CONNECTOR.</p> <p>1) Turn ignition switch to OFF. 2) Disconnect the connector from ECM. 3) Measure the resistance of harness between fuel pump connector and ECM.</p> <p>Connector & terminal (R58) No. 5 — (B136) No. 35:</p>	<p>Is the resistance less than 1 Ω?</p>	<p>Replace the fuel temperature sensor. <Ref. to EC(H4DOTC)-9, Fuel Temperature Sensor.></p>	<p>Repair harness and connector.</p> <p>NOTE: In this case, repair the following:</p> <ul style="list-style-type: none"> • Open circuit in harness between ECM and fuel pump connector • Poor contact in fuel pump connector • Poor contact in ECM connector • Poor contact in coupling connector • Poor contact in joint connector

DIAGNOSTIC PROCEDURE WITH DIAGNOSTIC TROUBLE CODE (DTC)

ENGINE (DIAGNOSTICS)

AJ:DTC P0222 — THROTTLE/PEDAL POSITION SENSOR/SWITCH “B” CIRCUIT LOW INPUT —

DTC DETECTING CONDITION:

- Immediately at fault recognition
- GENERAL DESCRIPTION <Ref. to GD(H4DOTC)-83, DTC P0222 — THROTTLE/PEDAL POSITION SENSOR/SWITCH “B” CIRCUIT LOW INPUT —, Diagnostic Trouble Code (DTC) Detecting Criteria.>

TROUBLE SYMPTOM:

- Erroneous idling
- Poor driving performance
- Engine stalls.

CAUTION:

After repair or replacement of faulty parts, conduct Clear Memory Mode <Ref. to EN(H4DOTC)-44, OPERATION, Clear Memory Mode.> and Inspection Mode <Ref. to EN(H4DOTC)-36, OPERATION, Inspection Mode.>.

DIAGNOSTIC PROCEDURE WITH DIAGNOSTIC TROUBLE CODE (DTC) ENGINE (DIAGNOSTICS)

WIRING DIAGRAM:

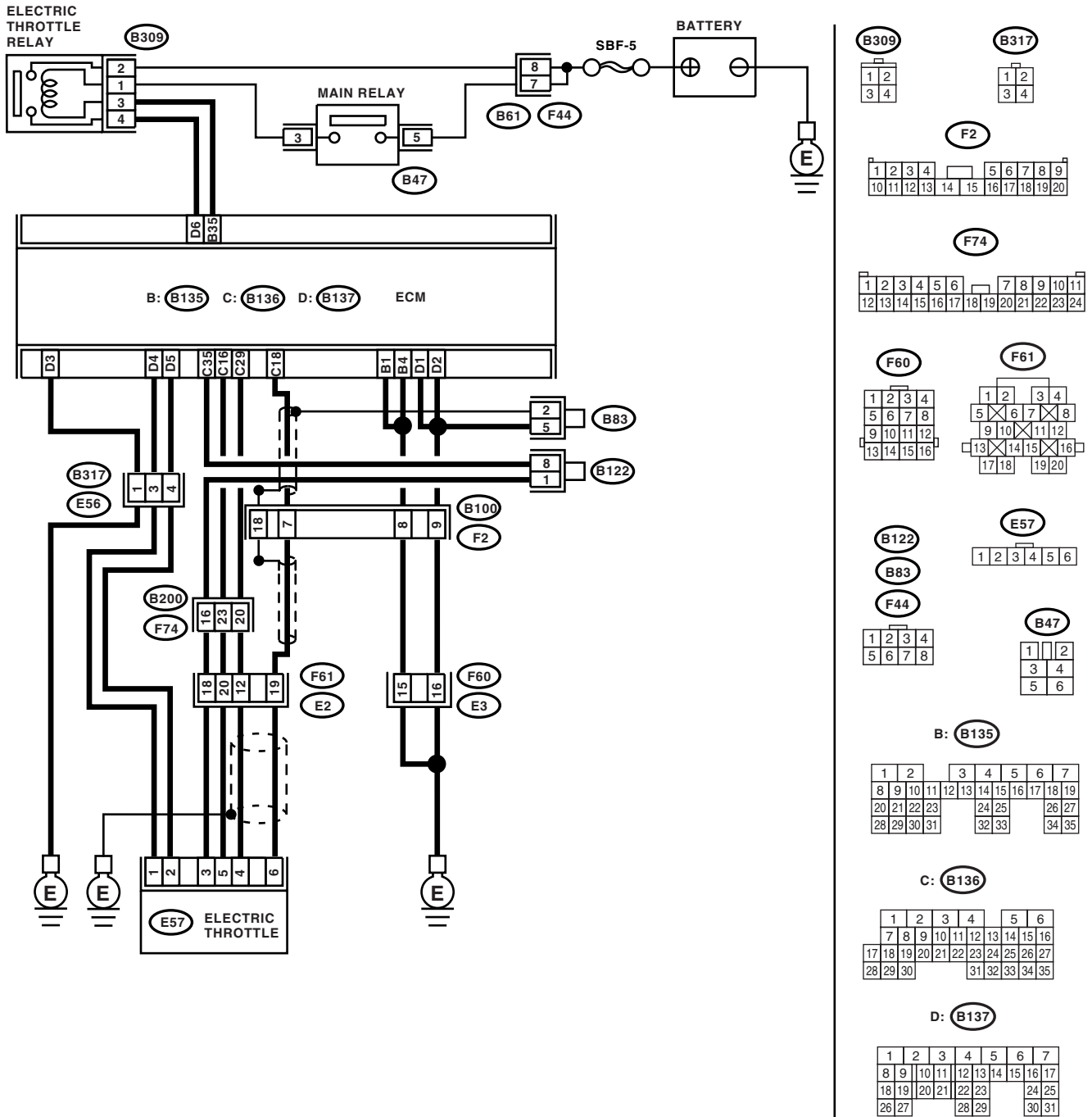

EN-02025

DIAGNOSTIC PROCEDURE WITH DIAGNOSTIC TROUBLE CODE (DTC)

ENGINE (DIAGNOSTICS)

Step	Check	Yes	No
1 CHECK OUTPUT VOLTAGE OF SENSOR. 1) Turn the ignition switch to ON. 2) Measure the voltage between ECM connector terminals. <i>Connector & terminal</i> <i>(B136) No. 29 (+) — (B136) No. 35 (-):</i> 3) Shake the ECM harness and connector, engine harness connectors (E84, E22), electric throttle connector harness while monitoring value of voltage meter.	Is the voltage more than 0.8 V?	Go to step 2.	Go to step 3.
2 CHECK POOR CONTACT IN CONNECTORS. Check poor contact in the connectors between the ECM and electric throttle.	Is there poor contact in the connectors between ECM and electric throttle?	Repair the poor contact in connectors.	Connector has returned to a normal condition at this time. A temporary poor contact of the connector may be the cause.
3 CHECK HARNESS BETWEEN ECM AND ELECTRIC THROTTLE. 1) Turn the ignition switch to OFF. 2) Disconnect the connector from ECM. 3) Disconnect the connector from electric throttle. 4) Measure the resistance between the ECM connector and electric throttle connector. <i>Connector & terminal</i> <i>(B136) No. 16 — (E57) No. 5:</i>	Is the resistance less than 1 Ω ?	Go to step 4.	Repair the open circuit of harness connector.
4 CHECK HARNESS BETWEEN ECM AND ELECTRIC THROTTLE. Check the resistance between the ECM connector and chassis ground. <i>Connector & terminal</i> <i>(B136) No. 29 — Chassis ground:</i> <i>(B136) No. 16 — Chassis ground:</i>	Is the resistance more than 1 M Ω ?	Go to step 5.	Repair the chassis short of harness.
5 CHECK POWER SUPPLY TO SENSOR. 1) Connect the ECM connectors. 2) Turn the ignition switch to ON. 3) Measure the voltage between electric throttle connector and engine ground. <i>Connector & terminal</i> <i>(E57) No. 5 (+) — Engine ground (-):</i> 4) Shake the ECM harness and connector, engine harness connectors, while monitoring value of voltage meter.	Is the voltage 4.5 — 5.5 V?	Go to step 6.	Repair the poor contact in ECM connector. If problem persists, replace the ECM. <Ref. to FU(H4DOTC)-42, Engine Control Module (ECM).>
6 CHECK SHORT OF ECM. 1) Turn the ignition switch to OFF. 2) Measure the resistance between electric throttle connector and engine ground. <i>Connector & terminal</i> <i>(E57) No. 4 — Engine ground:</i>	Is the resistance more than 10 Ω ?	Repair the poor contact in electric throttle connector. If problem persists, replace the electric throttle.	Repair the poor contact in ECM connectors. If problem persists, replace the ECM. <Ref. to FU(H4DOTC)-42, Engine Control Module (ECM).>

AK:DTC P0223 — THROTTLE/PEDAL POSITION SENSOR/SWITCH “B” CIRCUIT HIGH INPUT —

DTC DETECTING CONDITION:

- Immediately at fault recognition
- GENERAL DESCRIPTION <Ref. to GD(H4DOTC)-85, DTC P0223 — THROTTLE/PEDAL POSITION SENSOR/SWITCH “B” CIRCUIT HIGH INPUT —, Diagnostic Trouble Code (DTC) Detecting Criteria.>

TROUBLE SYMPTOM:

- Erroneous idling
- Poor driving performance
- Engine stalls.

CAUTION:

After repair or replacement of faulty parts, conduct Clear Memory Mode <Ref. to EN(H4DOTC)-44, OPERATION, Clear Memory Mode.> and Inspection Mode <Ref. to EN(H4DOTC)-36, OPERATION, Inspection Mode.>.

DIAGNOSTIC PROCEDURE WITH DIAGNOSTIC TROUBLE CODE (DTC) ENGINE (DIAGNOSTICS)

WIRING DIAGRAM:

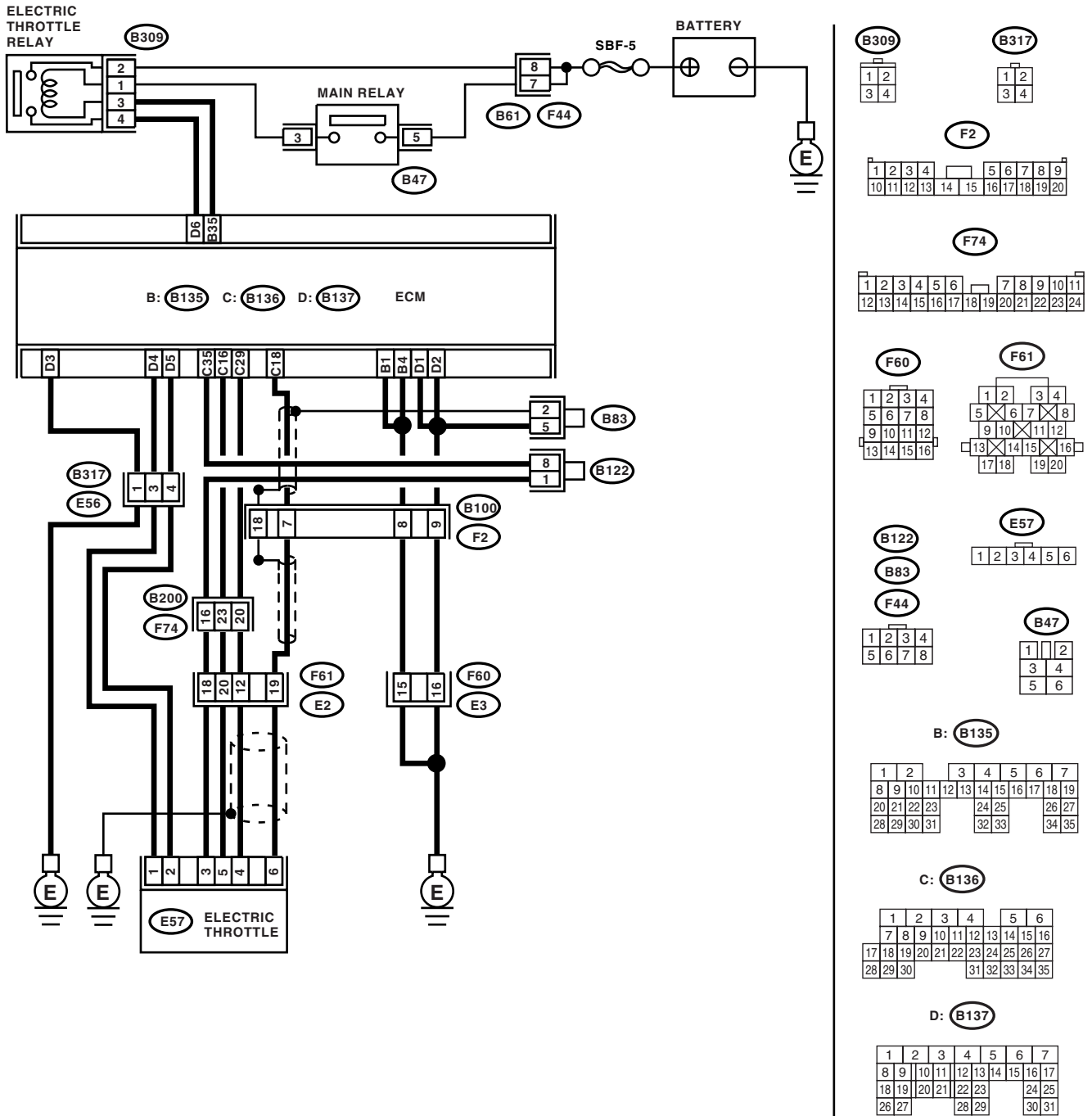

EN-02025

DIAGNOSTIC PROCEDURE WITH DIAGNOSTIC TROUBLE CODE (DTC)

ENGINE (DIAGNOSTICS)

Step	Check	Yes	No
1 CHECK OUTPUT VOLTAGE OF SENSOR. 1) Turn the ignition switch to ON. 2) Read the data of sub throttle sensor signals, using the Subaru Select Monitor. 3) Shake the ECM harness and connector, engine harness connectors, electric throttle connector harness while monitoring value of voltage meter.	Is the voltage less than 4.73 V?	Go to step 2.	Go to step 3.
2 CHECK POOR CONTACT IN CONNECTORS. Check poor contact in connectors between ECM and electric throttle.	Is there poor contact in the connectors between ECM and electric throttle?	Repair the poor contact in connectors.	Connector has returned to a normal condition at this time. A temporary poor contact of the connector may be the cause.
3 CHECK HARNESS BETWEEN ECM AND ELECTRIC THROTTLE. 1) Turn the ignition switch to OFF. 2) Disconnect the connectors from ECM. 3) Disconnect the connectors from electric throttle. 4) Measure the resistance between ECM connector and electric throttle connector. <i>Connector & terminal</i> <i>(B136) No. 35 — (E57) No. 3:</i> <i>(B136) No. 29 — (E57) No. 4:</i>	Is the resistance less than 1 Ω ?	Go to step 4.	Repair the open circuit of harness connector.
4 CHECK HARNESS BETWEEN ECM AND ELECTRIC THROTTLE. 1) Connect the ECM connector. 2) Measure the resistance between the electric throttle connector and engine ground. <i>Connector & terminal</i> <i>(E57) No. 3 — Engine ground:</i>	Is the resistance less than 5 Ω ?	Go to step 5.	Repair the poor contact in ECM connector. If the problem persists, replace the ECM. <Ref. to FU(H4DOTC)-42, Engine Control Module (ECM).>
5 CHECK HARNESS BETWEEN ECM AND ELECTRIC THROTTLE. 1) Connect the ECM connector. 2) Turn the ignition switch to ON. 3) Measure the voltage between electric throttle connector and engine ground. <i>Connector & terminal</i> <i>(E57) No. 5 — Engine ground:</i> 4) Shake the ECM harness and connector, engine harness connectors, while monitoring value of voltage meter.	Is the voltage more than 10 V?	Go to step 6.	Repair the battery short of harness between ECM connector and electric throttle connector.
6 CHECK HARNESS BETWEEN ECM AND ELECTRIC THROTTLE. 1) Measure the voltage between the electric throttle connector and engine ground. <i>Connector & terminal</i> <i>(E57) No. 4 (+) — Engine ground (-):</i> 2) Shake the ECM harness and connector, engine harness connectors, while monitoring value of voltage meter.	Is the voltage less than 10 V?	Go to step 7.	Repair the short of harness between ECM connector and electric throttle connector.

DIAGNOSTIC PROCEDURE WITH DIAGNOSTIC TROUBLE CODE (DTC)

ENGINE (DIAGNOSTICS)

	Step	Check	Yes	No
7	CHECK HARNESS BETWEEN ECM AND ELECTRIC THROTTLE. 1) Turn the ignition switch to OFF. 2) Disconnect the connector from ECM. 3) Measure the voltage between connectors. Connector & terminal (B136) No. 29 — (B136) No. 16:	Is the resistance more than 1 MΩ?	Repair the poor contact in electric throttle connector. If problem persists, replace the electric throttle.	Short circuit of sensor power supply may be the cause.

DIAGNOSTIC PROCEDURE WITH DIAGNOSTIC TROUBLE CODE (DTC)

ENGINE (DIAGNOSTICS)

AL:DTC P0230 — FUEL PUMP PRIMARY CIRCUIT —

DTC DETECTING CONDITION:

- Immediately at fault recognition
- GENERAL DESCRIPTION <Ref. to GD(H4DOTC)-87, DTC P0230 — FUEL PUMP PRIMARY CIRCUIT —, Diagnostic Trouble Code (DTC) Detecting Criteria.>

CAUTION:

After repair or replacement of faulty parts, conduct Clear Memory Mode <Ref. to EN(H4DOTC)-44, OPERATION, Clear Memory Mode.> and Inspection Mode <Ref. to EN(H4DOTC)-36, OPERATION, Inspection Mode.>.

WIRING DIAGRAM:

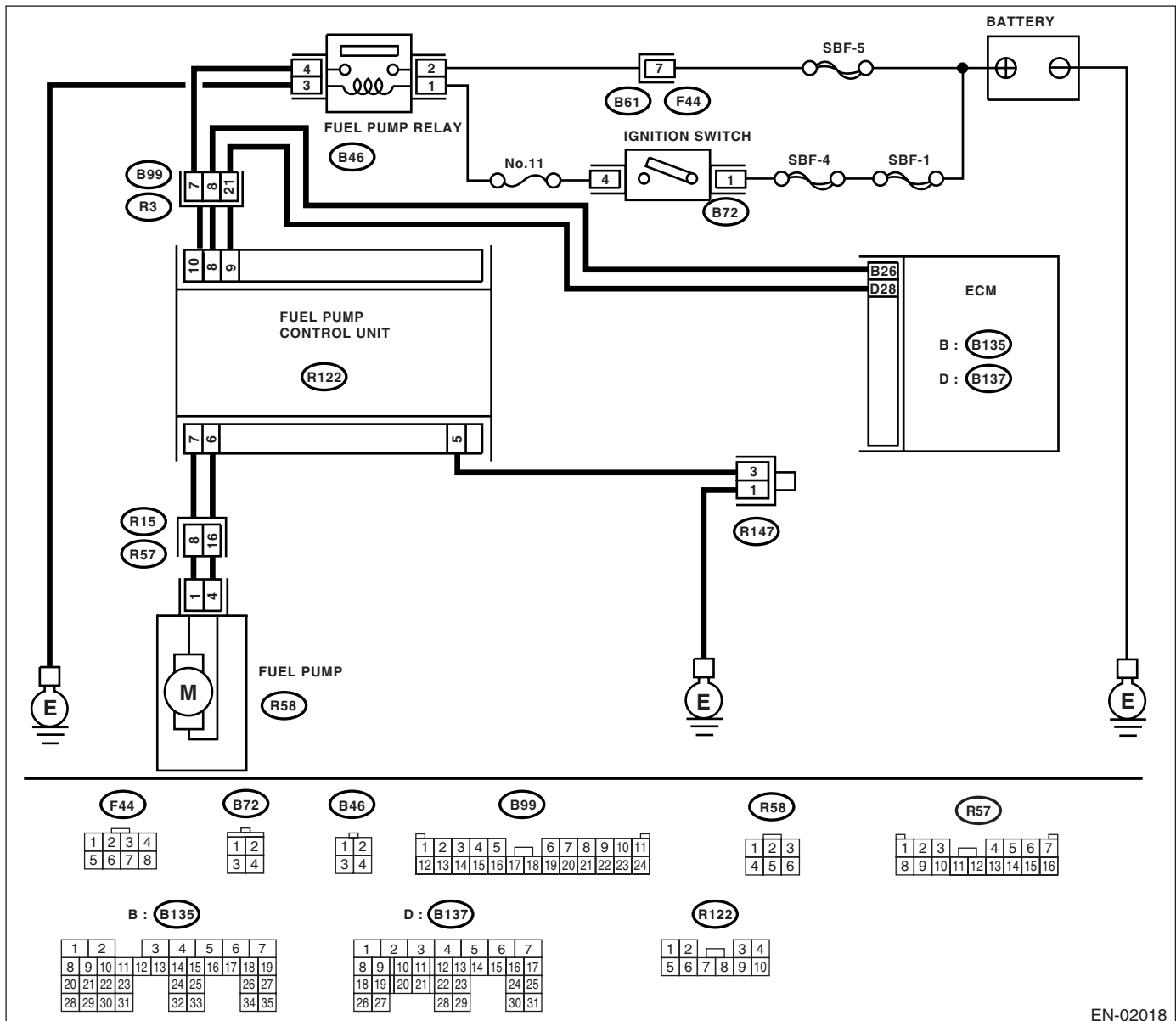

EN-02018

DIAGNOSTIC PROCEDURE WITH DIAGNOSTIC TROUBLE CODE (DTC)

ENGINE (DIAGNOSTICS)

Step	Check	Yes	No
1 CHECK POWER SUPPLY CIRCUIT TO FUEL PUMP CONTROL UNIT. 1) Turn the ignition switch to OFF. 2) Disconnect the connector from fuel pump control unit. 3) Turn the ignition switch to ON. 4) Measure the voltage between fuel pump control unit and chassis ground. Connector & terminal (R122) No. 10 (+) — Chassis ground (-):	Is the voltage more than 10 V?	Go to step 2.	Repair the power supply circuit. NOTE: In this case repair the following: • Open or ground short circuit in harness between fuel pump relay and fuel pump control unit • Poor contact in fuel pump control unit connector • Poor contact in fuel pump relay connector
2 CHECK GROUND CIRCUIT OF FUEL PUMP CONTROL UNIT. 1) Turn the ignition switch to OFF. 2) Measure the resistance of harness between fuel pump control unit and chassis ground. Connector & terminal (R122) No. 5 — Chassis ground:	Is the resistance less than 5 Ω ?	Go to step 3.	Repair the harness and connector. NOTE: In this case, repair the following: • Open circuit between fuel pump control unit and chassis ground • Poor contact in fuel pump control unit connector
3 CHECK HARNESS BETWEEN FUEL PUMP CONTROL UNIT AND FUEL PUMP CONNECTOR. 1) Disconnect the connector from fuel pump. 2) Measure the resistance of harness between fuel pump control unit and fuel pump connector. Connector & terminal (R122) No. 7 — (R58) No. 1: (R122) No. 6 — (R58) No. 4:	Is the resistance less than 1 Ω ?	Go to step 4.	Repair the open circuit between fuel pump control unit and fuel pump.
4 CHECK HARNESS BETWEEN FUEL PUMP CONTROL UNIT AND FUEL PUMP CONNECTOR. Measure the resistance of harness between fuel pump control unit and chassis ground. Connector & terminal (R122) No. 7 — Chassis ground: (R122) No. 6 — Chassis ground:	Is the resistance more than 1 $M\Omega$?	Go to step 5.	Repair the ground short circuit between fuel pump control unit and fuel pump.

DIAGNOSTIC PROCEDURE WITH DIAGNOSTIC TROUBLE CODE (DTC)

ENGINE (DIAGNOSTICS)

Step	Check	Yes	No
5 CHECK HARNESS BETWEEN FUEL PUMP CONTROL UNIT AND ECM CONNECTOR. 1) Turn the ignition switch to OFF. 2) Disconnect the connector from ECM. 3) Measure the resistance of harness between fuel pump control unit and ECM connector. <i>Connector & terminal</i> <i>(R122) No. 9 — (B137) No. 28:</i> <i>(R122) No. 8 — (B135) No. 26:</i>	Is the resistance less than 1 Ω ?	Go to step 6.	Repair the harness and connector. NOTE: In this case, repair the following: <ul style="list-style-type: none"> • Open circuit between fuel pump control unit and ECM • Poor contact in fuel pump control unit and ECM connector
6 CHECK HARNESS BETWEEN FUEL PUMP CONTROL UNIT AND ECM CONNECTOR. Measure the resistance of harness between fuel pump control unit and chassis ground. <i>Connector & terminal</i> <i>(R122) No. 9 — Chassis ground:</i> <i>(R122) No. 8 — Chassis ground:</i>	Is the resistance more than 1 $M\Omega$?	Go to step 7.	Repair the ground short circuit between fuel pump control unit and ECM.
7 CHECK POOR CONTACT. Check poor contact in ECM and fuel pump control unit connector.	Is there poor contact in ECM and fuel pump control unit connector?	Repair the poor contact in ECM and fuel pump control unit.	Go to step 8.
8 CHECK EXPERIENCE OF OUT OF GAS.	Have the vehicle been out of gas before?	Complete the diagnosis. NOTE: DTC may be recorded due to the idle running of fuel pump at out of gas.	Replace the fuel pump control unit. <Ref. to FU(H4DOTC)-45, Fuel Pump Control Unit.>

DIAGNOSTIC PROCEDURE WITH DIAGNOSTIC TROUBLE CODE (DTC)

ENGINE (DIAGNOSTICS)

AM:DTC P0244 — TURBO/SUPER CHARGER WASTEGATE SOLENOID “A” RANGE/PERFORMANCE —

DTC DETECTING CONDITION:

- Immediately at fault recognition
- GENERAL DESCRIPTION <Ref. to GD(H4DOTC)-89, DTC P0244 — TURBO/SUPER CHARGER WASTEGATE SOLENOID “A” RANGE/PERFORMANCE —, Diagnostic Trouble Code (DTC) Detecting Criteria.>

TROUBLE SYMPTOM:

- Erroneous idling
- Engine stalls.
- Poor driving performance

CAUTION:

After repair or replacement of faulty parts, conduct Clear Memory Mode <Ref. to EN(H4DOTC)-44, OPERATION, Clear Memory Mode.> and Inspection Mode <Ref. to EN(H4DOTC)-36, OPERATION, Inspection Mode.>.

WIRING DIAGRAM:

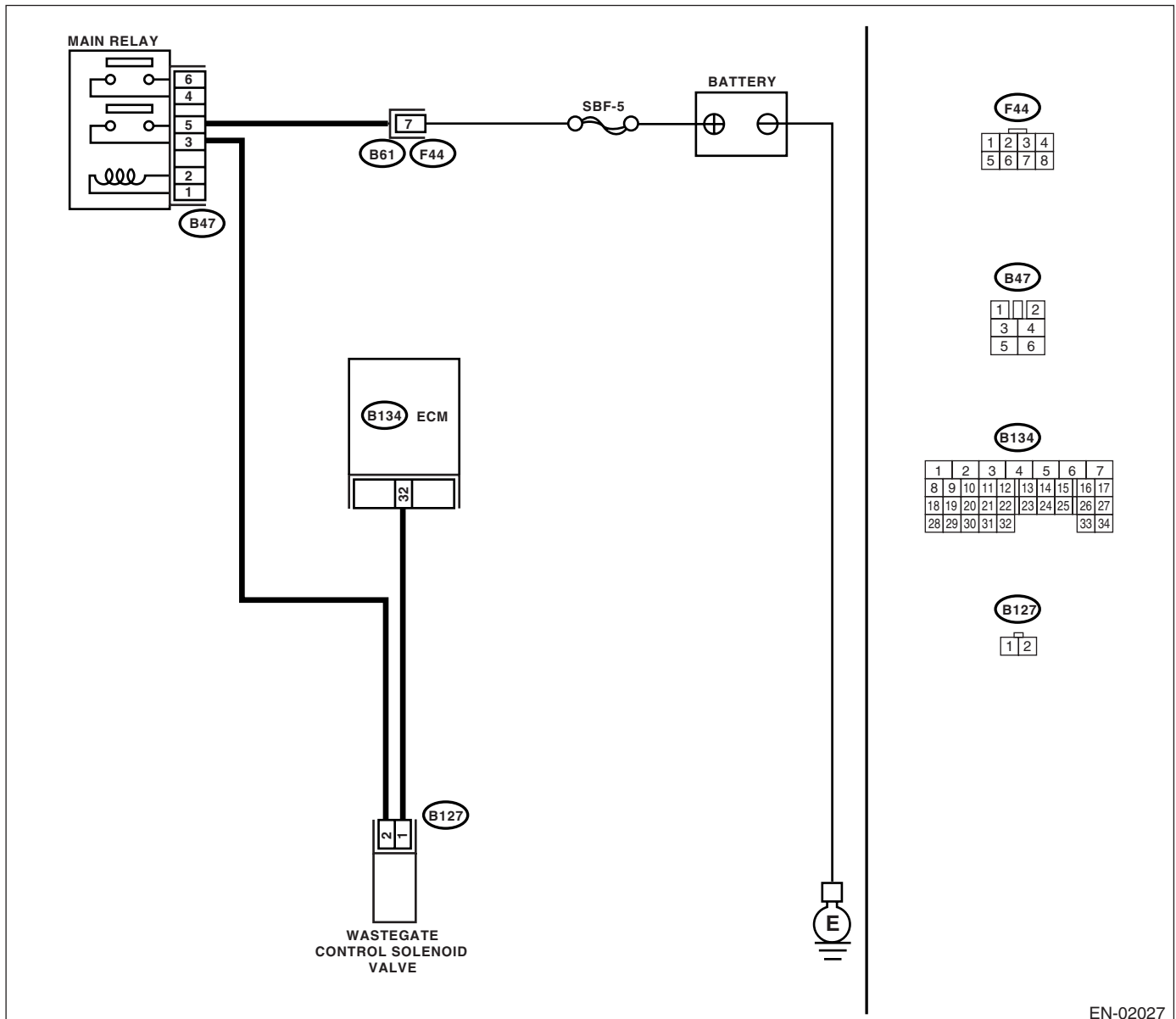

EN-02027

DIAGNOSTIC PROCEDURE WITH DIAGNOSTIC TROUBLE CODE (DTC)

ENGINE (DIAGNOSTICS)

Step	Check	Yes	No
1	CHECK ANY OTHER DTC ON DISPLAY.	Is any other DTC displayed?	Inspect the relevant DTC using "List of Diagnostic Trouble Code (DTC)". <Ref. to EN(H4DOTC)-68, List of Diagnostic Trouble Code (DTC).> NOTE: In this case, it is not necessary to inspect DTC P0244.
			Replace the wastegate control solenoid valve. <Ref. to FU(H4DOTC)-36, Wastegate Control Solenoid Valve.>

DIAGNOSTIC PROCEDURE WITH DIAGNOSTIC TROUBLE CODE (DTC)

ENGINE (DIAGNOSTICS)

AN:DTC P0245 — TURBO/SUPER CHARGER WASTEGATE SOLENOID “A” LOW —

DTC DETECTING CONDITION:

- Immediately at fault recognition
- GENERAL DESCRIPTION <Ref. to GD(H4DOTC)-91, DTC P0245 — TURBO/SUPER CHARGER WASTEGATE SOLENOID “A” LOW —, Diagnostic Trouble Code (DTC) Detecting Criteria.>

TROUBLE SYMPTOM:

Erroneous idling

CAUTION:

After repair or replacement of faulty parts, conduct Clear Memory Mode <Ref. to EN(H4DOTC)-44, OPERATION, Clear Memory Mode.> and Inspection Mode <Ref. to EN(H4DOTC)-36, OPERATION, Inspection Mode.>.

WIRING DIAGRAM:

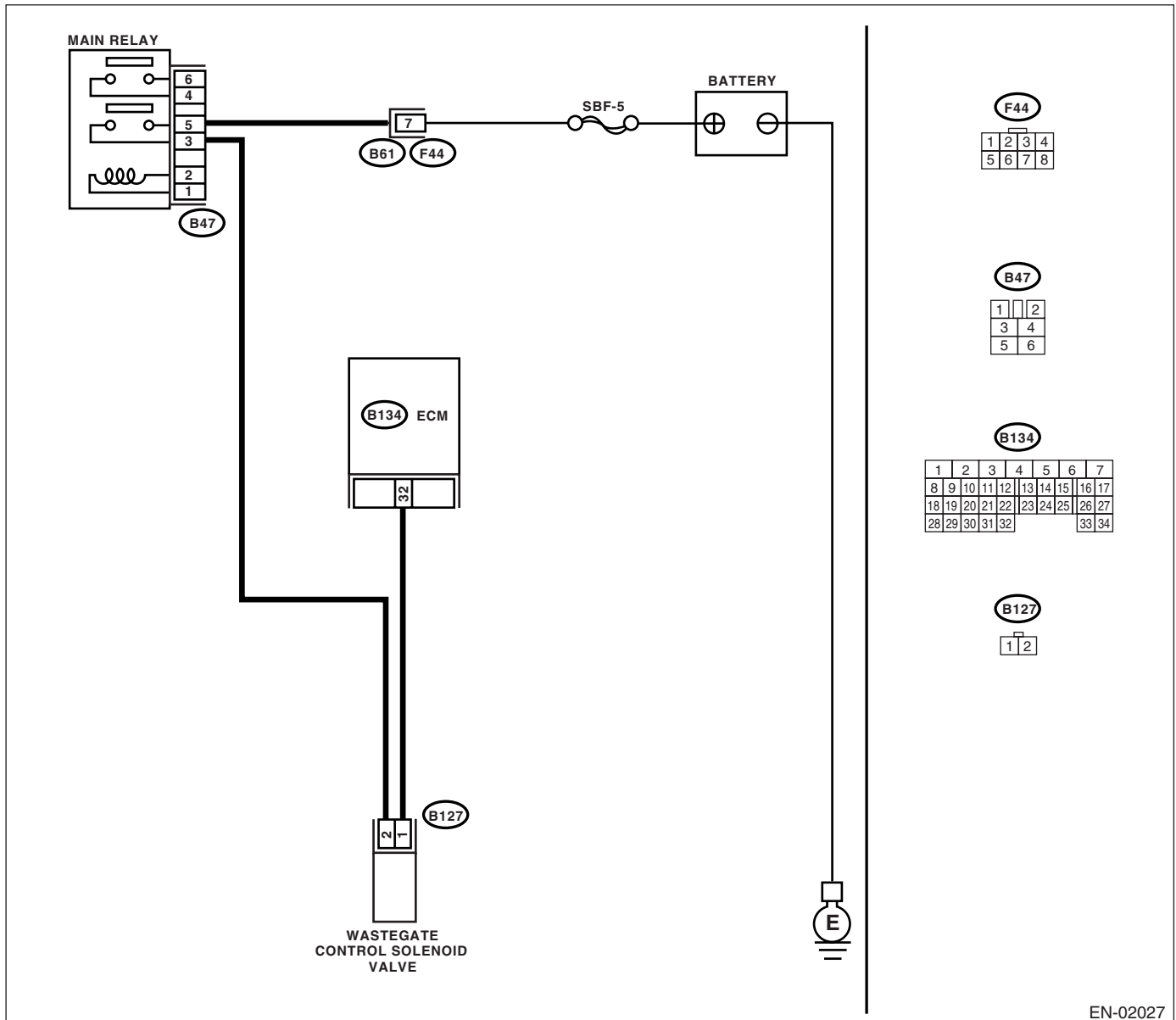

EN-02027

DIAGNOSTIC PROCEDURE WITH DIAGNOSTIC TROUBLE CODE (DTC)

ENGINE (DIAGNOSTICS)

Step	Check	Yes	No
1 CHECK OUTPUT SIGNAL FROM ECM. 1) Turn the ignition switch to ON. 2) Measure the voltage between ECM and chassis ground. <i>Connector & terminal</i> <i>(B134) No. 32 (+) — Chassis ground (-):</i>	Is the voltage more than 10 V?	Even if malfunction indicator light lights up, the circuit has returned to a normal condition at this time.	Go to step 2.
2 CHECK HARNESS BETWEEN WASTEGATE CONTROL SOLENOID VALVE AND ECM CONNECTOR. 1) Turn the ignition switch to OFF. 2) Disconnect the connectors from wastegate control solenoid valve and ECM. 3) Measure the resistance of harness between wastegate control solenoid valve connector and engine ground. <i>Connector & terminal</i> <i>(B127) No. 1 — Engine ground:</i>	Is the resistance less than 10 Ω ?	Repair the ground short circuit in harness between ECM and wastegate control solenoid valve connector.	Go to step 3.
3 CHECK HARNESS BETWEEN WASTEGATE CONTROL SOLENOID VALVE AND ECM CONNECTOR. Measure the resistance of harness between ECM and wastegate control solenoid valve of harness connector. <i>Connector & terminal</i> <i>(B134) No. 32 — (B127) No. 1:</i>	Is the resistance less than 1 Ω ?	Go to step 4.	Repair the open circuit in harness between ECM and wastegate control solenoid valve connector. NOTE: In this case, repair the following: • Open circuit in harness between ECM and wastegate control solenoid valve connector
4 CHECK WASTEGATE CONTROL SOLENOID VALVE. 1) Remove the wastegate control solenoid valve. 2) Measure the resistance between wastegate control solenoid valve terminals. <i>Terminals</i> <i>No. 1 — No. 2:</i>	Is the resistance 30 — 40 Ω ?	Go to step 5.	Replace the wastegate control solenoid valve. <Ref. to FU(H4DOTC)-36, Wastegate Control Solenoid Valve.>
5 CHECK POWER SUPPLY TO WASTEGATE CONTROL SOLENOID VALVE. 1) Turn the ignition switch to ON. 2) Measure the voltage between wastegate control solenoid valve and engine ground. <i>Connector & terminal</i> <i>(B127) No. 2 (+) — Engine ground (-):</i>	Is the voltage more than 10 V?	Go to step 6.	Repair the open circuit in harness between main relay and wastegate control solenoid valve connector.
6 CHECK POOR CONTACT. Check poor contact in wastegate control solenoid valve connector.	Is there poor contact in wastegate control solenoid valve connector?	Repair the poor contact in wastegate control solenoid valve connector.	Contact your SOA Service Center. NOTE: Inspection by DTM is required, because probable cause is deterioration of multiple parts.

DIAGNOSTIC PROCEDURE WITH DIAGNOSTIC TROUBLE CODE (DTC)
 ENGINE (DIAGNOSTICS)

AO:DTC P0246 — TURBO/SUPER CHARGER WASTEGATE SOLENOID “A” HIGH —

DTC DETECTING CONDITION:

- Immediately at fault recognition
- GENERAL DESCRIPTION <Ref. to GD(H4DOTC)-93, DTC P0246 — TURBO/SUPER CHARGER WASTEGATE SOLENOID “A” HIGH —, Diagnostic Trouble Code (DTC) Detecting Criteria.>

TROUBLE SYMPTOM:

Erroneous idling

CAUTION:

After repair or replacement of faulty parts, conduct Clear Memory Mode <Ref. to EN(H4DOTC)-44, OPERATION, Clear Memory Mode.> and Inspection Mode <Ref. to EN(H4DOTC)-36, OPERATION, Inspection Mode.>.

WIRING DIAGRAM:

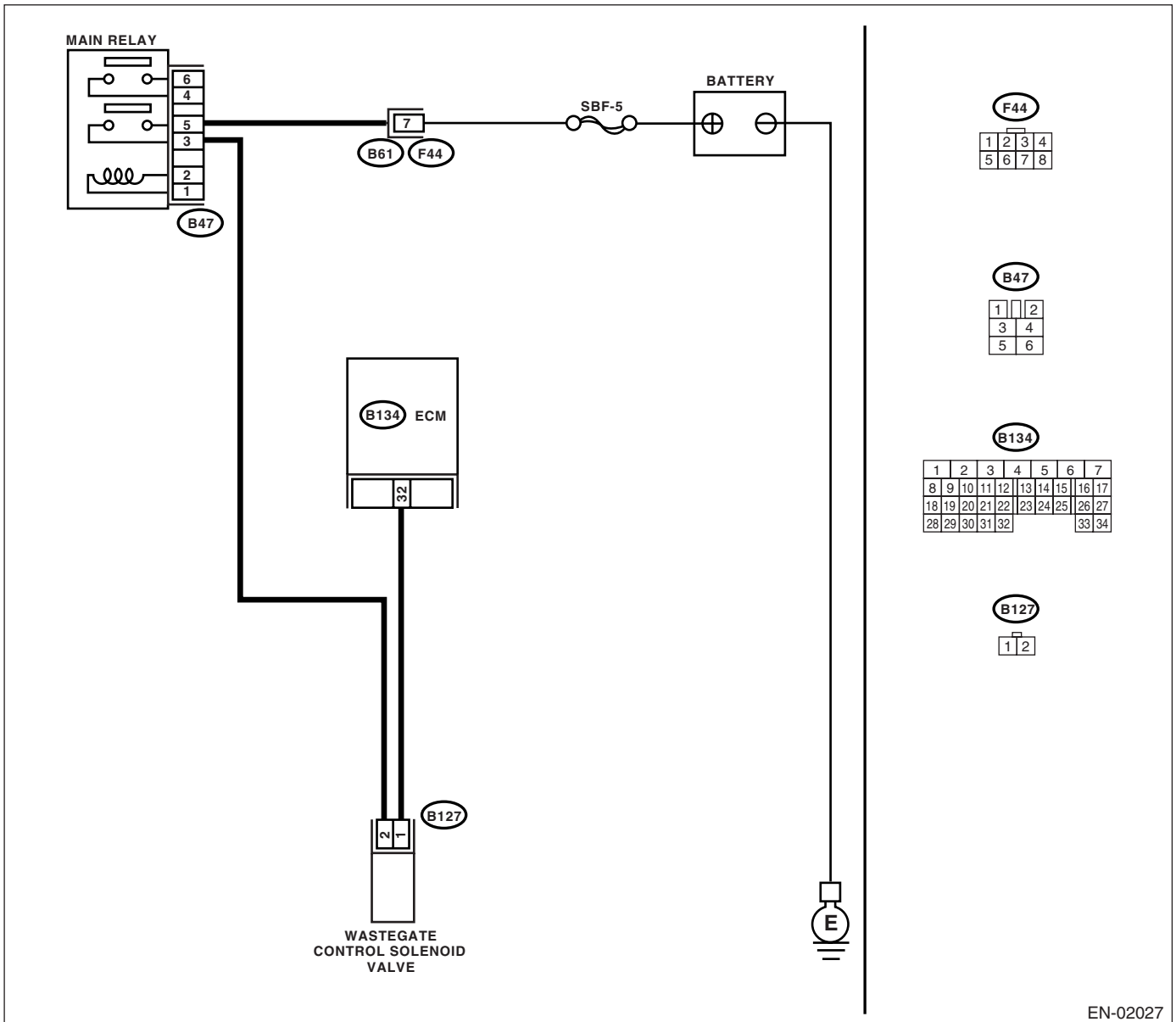

EN-02027

DIAGNOSTIC PROCEDURE WITH DIAGNOSTIC TROUBLE CODE (DTC)

ENGINE (DIAGNOSTICS)

Step	Check	Yes	No
1 CHECK OUTPUT SIGNAL FROM ECM. 1) Turn the ignition switch to ON. 2) Measure the voltage between ECM and chassis ground. <i>Connector & terminal</i> <i>(B134) No. 32 (+) — Chassis ground (-):</i>	Is the voltage more than 10 V?	Go to step 3.	Go to step 2.
2 CHECK POOR CONTACT. Check poor contact in ECM connector.	Is there poor contact in ECM connector?	Repair the poor contact in ECM connector.	Replace the ECM. <Ref. to FU(H4DOTC)-42, Engine Control Module (ECM).>
3 CHECK HARNESS BETWEEN WASTEGATE CONTROL SOLENOID VALVE AND ECM CONNECTOR. 1) Turn the ignition switch to OFF. 2) Disconnect the connector from wastegate control solenoid valve. 3) Turn the ignition switch to ON. 4) Measure the voltage between ECM and chassis ground. <i>Connector & terminal</i> <i>(B134) No. 32 (+) — Chassis ground (-):</i>	Is the voltage more than 10 V?	Repair the battery short circuit in harness between ECM and wastegate control solenoid valve connector. After repair, replace the ECM. <Ref. to FU(H4DOTC)-42, Engine Control Module (ECM).>	Go to step 4.
4 CHECK WASTEGATE CONTROL SOLENOID VALVE. 1) Turn the ignition switch to OFF. 2) Measure the resistance between wastegate control solenoid valve terminals. <i>Terminals</i> <i>No. 1 — No. 2:</i>	Is the resistance less than 1 Ω ?	Replace the wastegate control solenoid valve <Ref. to FU(H4DOTC)-36, Wastegate Control Solenoid Valve.> and ECM <Ref. to FU(H4DOTC)-42, Engine Control Module (ECM).>	Go to step 5.
5 CHECK POOR CONTACT. Check poor contact in ECM connector.	Is there poor contact in ECM connector?	Repair the poor contact in ECM connector.	Replace the ECM. <Ref. to FU(H4DOTC)-42, Engine Control Module (ECM).>

DIAGNOSTIC PROCEDURE WITH DIAGNOSTIC TROUBLE CODE (DTC)

ENGINE (DIAGNOSTICS)

AP:DTC P0301 — CYLINDER 1 MISFIRE DETECTED —

NOTE:

For the diagnostic procedure, refer to DTC P0304. <Ref. to EN(H4DOTC)-169, DTC P0304 — CYLINDER 4 MISFIRE DETECTED —, Diagnostic Procedure with Diagnostic Trouble Code (DTC).>

AQ:DTC P0302 — CYLINDER 2 MISFIRE DETECTED —

NOTE:

For the diagnostic procedure, refer to DTC P0304. <Ref. to EN(H4DOTC)-169, DTC P0304 — CYLINDER 4 MISFIRE DETECTED —, Diagnostic Procedure with Diagnostic Trouble Code (DTC).>

AR:DTC P0303 — CYLINDER 3 MISFIRE DETECTED —

NOTE:

For the diagnostic procedure, refer to DTC P0304. <Ref. to EN(H4DOTC)-169, DTC P0304 — CYLINDER 4 MISFIRE DETECTED —, Diagnostic Procedure with Diagnostic Trouble Code (DTC).>

AS:DTC P0304 — CYLINDER 4 MISFIRE DETECTED —

DTC DETECTING CONDITION:

- Two consecutive driving cycles with fault
- Immediately at fault recognition (A misfire which could damage catalyst occurs.)
- GENERAL DESCRIPTION <Ref. to GD(H4DOTC)-95, DTC P0301 — CYLINDER 1 MISFIRE DETECTED —, Diagnostic Trouble Code (DTC) Detecting Criteria.>

TROUBLE SYMPTOM:

- Engine stalls.
- Erroneous idling
- Rough driving

CAUTION:

After repair or replacement of faulty parts, conduct Clear Memory Mode <Ref. to EN(H4DOTC)-44, OPERATION, Clear Memory Mode.> and Inspection Mode <Ref. to EN(H4DOTC)-36, OPERATION, Inspection Mode.>.

DIAGNOSTIC PROCEDURE WITH DIAGNOSTIC TROUBLE CODE (DTC) ENGINE (DIAGNOSTICS)

WIRING DIAGRAM:

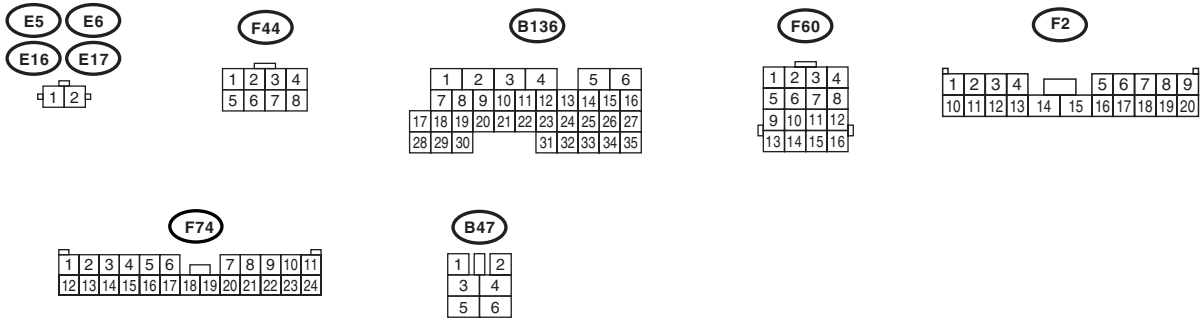
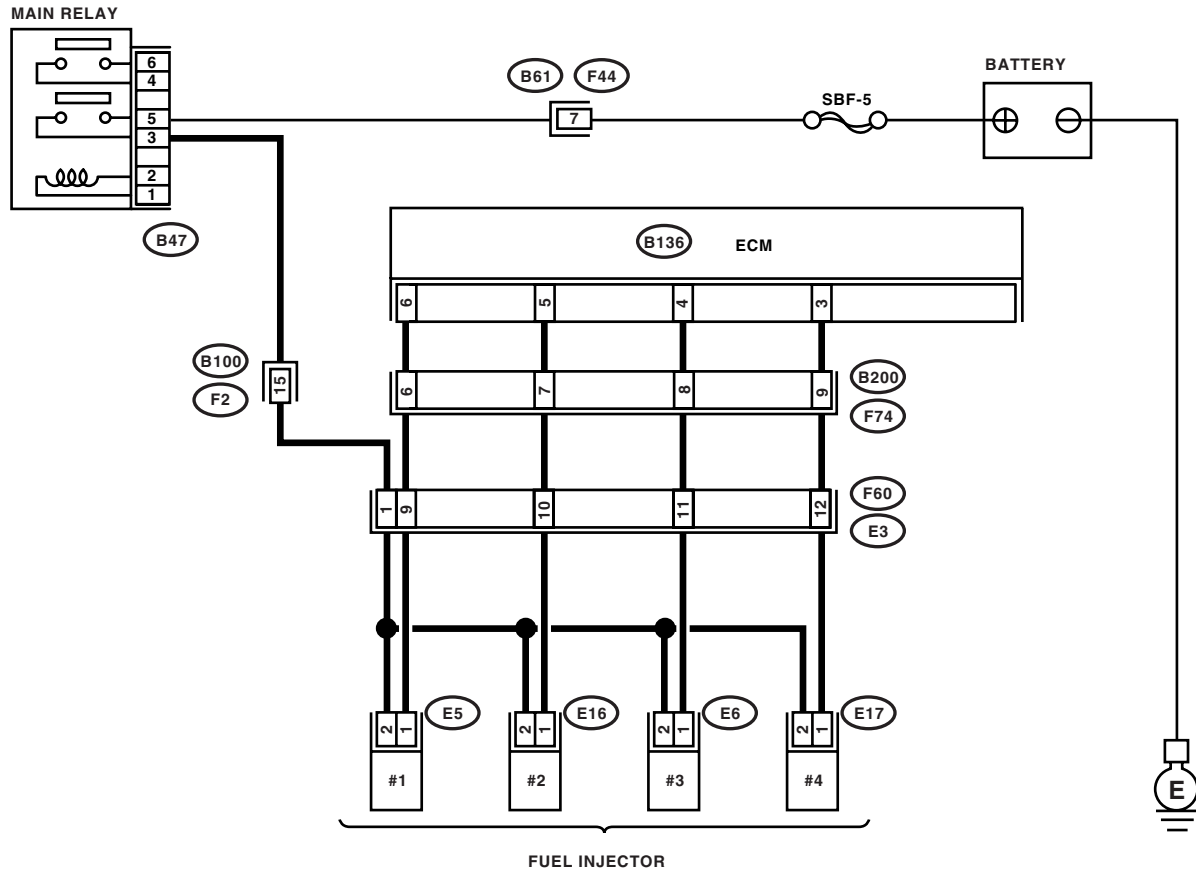

EN-02019

DIAGNOSTIC PROCEDURE WITH DIAGNOSTIC TROUBLE CODE (DTC)

ENGINE (DIAGNOSTICS)

Step	Check	Yes	No
<p>1</p> <p>CHECK ANY OTHER DTC ON DISPLAY.</p>	<p>Is any other DTC displayed?</p>	<p>Inspect the relevant DTC using "List of Diagnostic Trouble Code (DTC)". <Ref. to EN(H4DOTC)-68, List of Diagnostic Trouble Code (DTC).></p>	<p>Go to step 2.</p>
<p>2</p> <p>CHECK OUTPUT SIGNAL FROM ECM.</p> <p>1) Turn the ignition switch to ON. 2) Measure the voltage between ECM connector and chassis ground on faulty cylinders.</p> <p>Connector & terminal</p> <p>#1 (B136) No. 6 (+) — Chassis ground (-): #2 (B136) No. 5 (+) — Chassis ground (-): #3 (B136) No. 4 (+) — Chassis ground (-): #4 (B136) No. 3 (+) — Chassis ground (-):</p>	<p>Is the voltage more than 10 V?</p>	<p>Go to step 7.</p>	<p>Go to step 3.</p>
<p>3</p> <p>CHECK HARNESS BETWEEN FUEL INJECTOR AND ECM CONNECTOR.</p> <p>1) Turn the ignition switch to OFF. 2) Disconnect the connector from fuel injector on faulty cylinders. 3) Disconnect the connector from ECM. 4) Measure the resistance between ECM connector and engine ground on faulty cylinders.</p> <p>Connector & terminal</p> <p>#1 (E5) No. 1 — Engine ground: #2 (E16) No. 1 — Engine ground: #3 (E6) No. 1 — Engine ground: #4 (E17) No. 1 — Engine ground:</p>	<p>Is the resistance more than 1 MΩ?</p>	<p>Go to step 4.</p>	<p>Repair the ground short circuit in harness between fuel injector and ECM connector.</p>
<p>4</p> <p>CHECK HARNESS BETWEEN FUEL INJECTOR AND ECM CONNECTOR.</p> <p>Measure the resistance of harness connector between ECM connector and fuel injector on faulty cylinders.</p> <p>Connector & terminal</p> <p>#1 (B136) No. 6 — (E5) No. 1: #2 (B136) No. 5 — (E16) No. 1: #3 (B136) No. 4 — (E6) No. 1: #4 (B136) No. 3 — (E17) No. 1:</p>	<p>Is the resistance less than 1 Ω?</p>	<p>Go to step 5.</p>	<p>Repair the harness and connector.</p> <p>NOTE: In this case, repair the following:</p> <ul style="list-style-type: none"> • Open circuit in harness between ECM and fuel injector connector • Poor contact in coupling connector
<p>5</p> <p>CHECK FUEL INJECTOR.</p> <p>Measure the resistance between fuel injector terminals on faulty cylinder.</p> <p>Terminals</p> <p>No. 1 — No. 2:</p>	<p>Is the resistance 5 — 20 Ω?</p>	<p>Go to step 6.</p>	<p>Replace the faulty fuel injector. <Ref. to FU(H4DOTC)-32, Fuel Injector.></p>

DIAGNOSTIC PROCEDURE WITH DIAGNOSTIC TROUBLE CODE (DTC)

ENGINE (DIAGNOSTICS)

Step	Check	Yes	No
6 CHECK POWER SUPPLY LINE. 1) Turn the ignition switch to ON. 2) Measure the voltage between fuel injector and engine ground on faulty cylinders. Connector & terminal #1 (E5) No. 2 (+) — Engine ground (-): #2 (E16) No. 2 (+) — Engine ground (-): #3 (E6) No. 2 (+) — Engine ground (-): #4 (E17) No. 2 (+) — Engine ground (-):	Is the voltage more than 10 V?	Repair the poor contact in all connectors in fuel injector circuit.	Repair the harness and connector. NOTE: In this case, repair the following: <ul style="list-style-type: none"> • Open circuit in harness between main relay and fuel injector connector on faulty cylinders • Poor contact in coupling connector • Poor contact in main relay connector • Poor contact in fuel injector connector on faulty cylinders
7 CHECK HARNESS BETWEEN FUEL INJECTOR AND ECM CONNECTOR. 1) Turn the ignition switch to OFF. 2) Disconnect the connector from fuel injector on faulty cylinder. 3) Turn the ignition switch to ON. 4) Measure the voltage between ECM connector and chassis ground on faulty cylinders. Connector & terminal #1 (B136) No. 6 (+) — Chassis ground (-): #2 (B136) No. 5 (+) — Chassis ground (-): #3 (B136) No. 4 (+) — Chassis ground (-): #4 (B136) No. 3 (+) — Chassis ground (-):	Is the voltage more than 10 V?	Repair the battery short circuit in harness between ECM and fuel injector. After repair, replace the ECM. <Ref. to FU(H4DOTC)-42, Engine Control Module (ECM).>	Go to step 8.
8 CHECK FUEL INJECTOR. 1) Turn the ignition switch to OFF. 2) Measure the resistance between fuel injector terminals on faulty cylinder. Terminals No. 1 — No. 2:	Is the resistance less than 1 Ω ?	Replace the faulty fuel injector <Ref. to FU(H4DOTC)-32, Fuel Injector.> and ECM <Ref. to FU(H4DOTC)-42, Engine Control Module (ECM).>	Go to step 9.
9 CHECK INSTALLATION OF CAMSHAFT POSITION SENSOR/CRANKSHAFT POSITION SENSOR.	Is the camshaft position sensor or crankshaft position sensor loosely installed?	Tighten the camshaft position sensor or crankshaft position sensor.	Go to step 10.
10 CHECK CRANK SPROCKET. Remove the timing belt cover.	Is the crank sprocket rusted or does it have broken teeth?	Replace the crank sprocket. <Ref. to ME(H4DOTC)-60, Crank Sprocket.>	Go to step 11.
11 CHECK INSTALLATION CONDITION OF TIMING BELT. Turn the crankshaft, and align alignment mark on crank sprocket with alignment mark on cylinder block.	Is the timing belt dislocated from its proper position?	Repair the installation condition of timing belt. <Ref. to ME(H4DOTC)-50, Timing Belt Assembly.>	Go to step 12.

DIAGNOSTIC PROCEDURE WITH DIAGNOSTIC TROUBLE CODE (DTC)

ENGINE (DIAGNOSTICS)

Step	Check	Yes	No
12	CHECK FUEL LEVEL.	Go to step 13 .	Replenish the fuel so fuel meter indication is higher than the "Lower" level. After replenishing fuel; Go to step 13 .
13	CHECK STATUS OF MALFUNCTION INDICATOR LIGHT. 1) Clear the memory using Subaru Select Monitor. <Ref. to EN(H4DOTC)-44, Clear Memory Mode.> 2) Start the engine, and drive the vehicle more than 10 minutes.	Go to step 15 .	Go to step 14 .
14	CHECK CAUSE OF MISFIRE DIAGNOSED.	Finish the diagnostics operation, if the engine has no abnormality.	Repair the poor contact. NOTE: In this case, repair the following: <ul style="list-style-type: none"> • Poor contact in ignition coil connector • Poor contact in fuel injector connector on faulty cylinders • Poor contact in ECM connector • Poor contact in coupling connector
15	CHECK AIR INTAKE SYSTEM.	Repair the air intake system. NOTE: Check the following items: <ul style="list-style-type: none"> • Are there air leaks or air suction caused by loose or dislocated nuts and bolts? • Are there cracks or any disconnection of hoses? 	Go to step 16 .
16	CHECK CYLINDER.	Repair or replace the faulty parts. NOTE: Check the following items. <ul style="list-style-type: none"> • Spark plug • Fuel injector • Compression pressure 	Go to DTC P0171 and P0172. <Ref. to EN(H4DOTC)-141, DTC P0171 — SYSTEM TOO LEAN (BANK 1) —, Diagnostic Procedure with Diagnostic Trouble Code (DTC).>

DIAGNOSTIC PROCEDURE WITH DIAGNOSTIC TROUBLE CODE (DTC)

ENGINE (DIAGNOSTICS)

AT:DTC P0327 — KNOCK SENSOR 1 CIRCUIT LOW INPUT (BANK 1 OR SINGLE SENSOR) —

DTC DETECTING CONDITION:

- Immediately at fault recognition
- GENERAL DESCRIPTION <Ref. to GD(H4DOTC)-103, DTC P0327 — KNOCK SENSOR 1 CIRCUIT LOW INPUT (BANK 1 OR SINGLE SENSOR) —, Diagnostic Trouble Code (DTC) Detecting Criteria.>

TROUBLE SYMPTOM:

- Poor driving performance
- Knocking occurs.

CAUTION:

After repair or replacement of faulty parts, conduct Clear Memory Mode <Ref. to EN(H4DOTC)-44, OPERATION, Clear Memory Mode.> and Inspection Mode <Ref. to EN(H4DOTC)-36, OPERATION, Inspection Mode.>.

WIRING DIAGRAM:

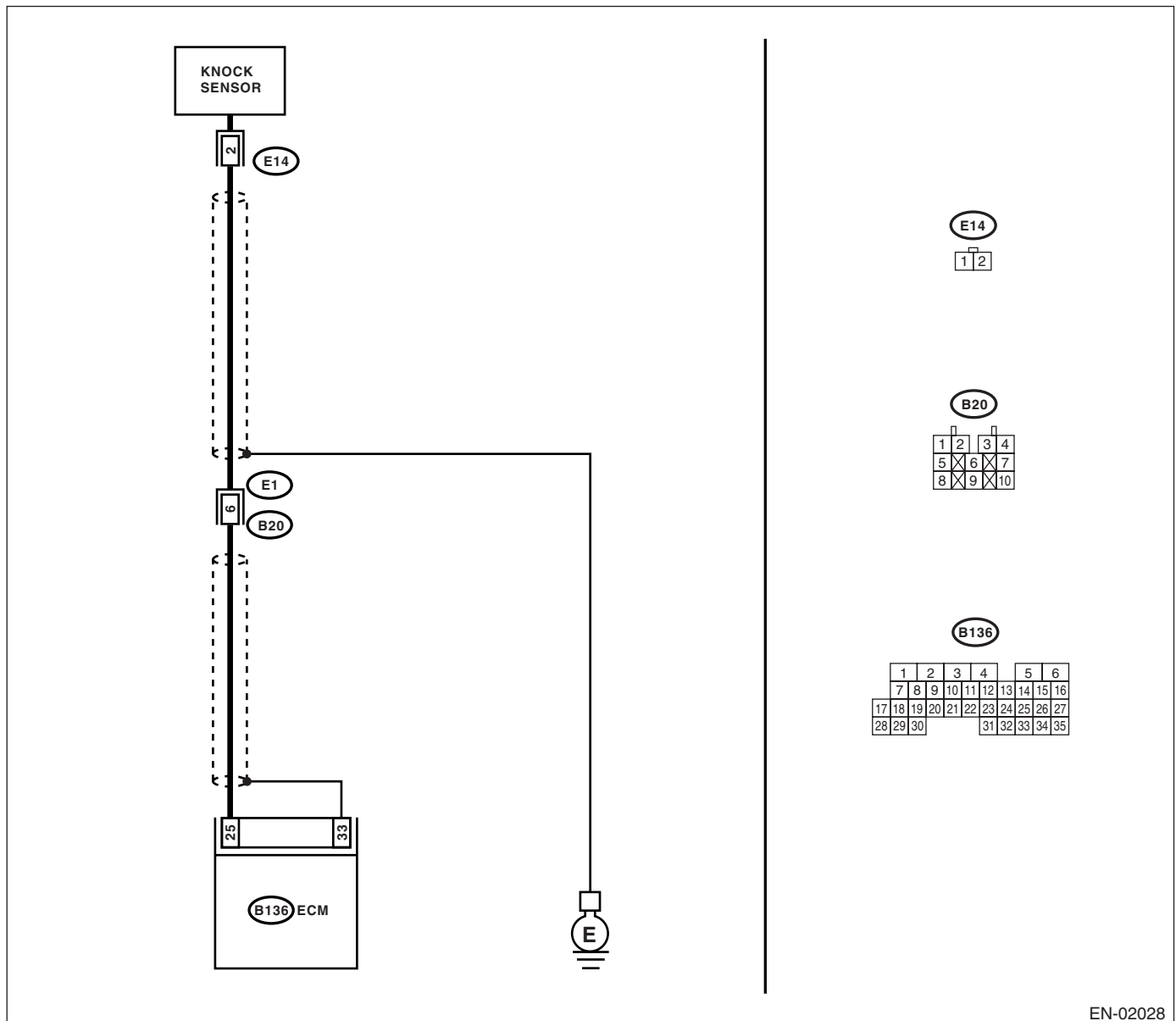

EN-02028

DIAGNOSTIC PROCEDURE WITH DIAGNOSTIC TROUBLE CODE (DTC)

ENGINE (DIAGNOSTICS)

Step	Check	Yes	No
<p>1</p> <p>CHECK HARNESS BETWEEN KNOCK SENSOR AND ECM CONNECTOR.</p> <p>1) Turn the ignition switch to OFF. 2) Disconnect the connector from ECM. 3) Measure the resistance between ECM harness connector and chassis ground.</p> <p>Connector & terminal (B136) No. 25 — Chassis ground:</p>	<p>Is the resistance more than 700 kΩ?</p>	<p>Go to step 2.</p>	<p>Repair the harness and connector.</p> <p>NOTE: In this case, repair the following:</p> <ul style="list-style-type: none"> • Open circuit in harness between knock sensor and ECM connector • Poor contact in knock sensor connector • Poor contact in coupling connector
<p>2</p> <p>CHECK KNOCK SENSOR.</p> <p>1) Disconnect the connector from knock sensor. 2) Measure the resistance between knock sensor connector terminal and engine ground.</p> <p>Terminals No. 2 — Engine ground:</p>	<p>Is the resistance more than 700 kΩ?</p>	<p>Go to step 3.</p>	<p>Repair the harness and connector.</p> <p>NOTE: In this case, repair the following:</p> <ul style="list-style-type: none"> • Poor contact in knock sensor connector • Poor contact in coupling connector
<p>3</p> <p>CHECK CONDITION OF KNOCK SENSOR INSTALLATION.</p>	<p>Is the knock sensor installation bolt tightened securely?</p>	<p>Replace the knock sensor. <Ref. to FU(H4DOTC)-29, Knock Sensor.></p>	<p>Tighten the knock sensor installation bolt securely.</p>

DIAGNOSTIC PROCEDURE WITH DIAGNOSTIC TROUBLE CODE (DTC)

ENGINE (DIAGNOSTICS)

AU:DTC P0328 — KNOCK SENSOR 1 CIRCUIT HIGH INPUT (BANK 1 OR SINGLE SENSOR) —

DTC DETECTING CONDITION:

- Immediately at fault recognition
- GENERAL DESCRIPTION <Ref. to GD(H4DOTC)-105, DTC P0328 — KNOCK SENSOR 1 CIRCUIT HIGH INPUT (BANK 1 OR SINGLE SENSOR) —, Diagnostic Trouble Code (DTC) Detecting Criteria.>

TROUBLE SYMPTOM:

- Poor driving performance
- Knocking occurs.

CAUTION:

After repair or replacement of faulty parts, conduct Clear Memory Mode <Ref. to EN(H4DOTC)-44, OPERATION, Clear Memory Mode.> and Inspection Mode <Ref. to EN(H4DOTC)-36, OPERATION, Inspection Mode.>.

WIRING DIAGRAM:

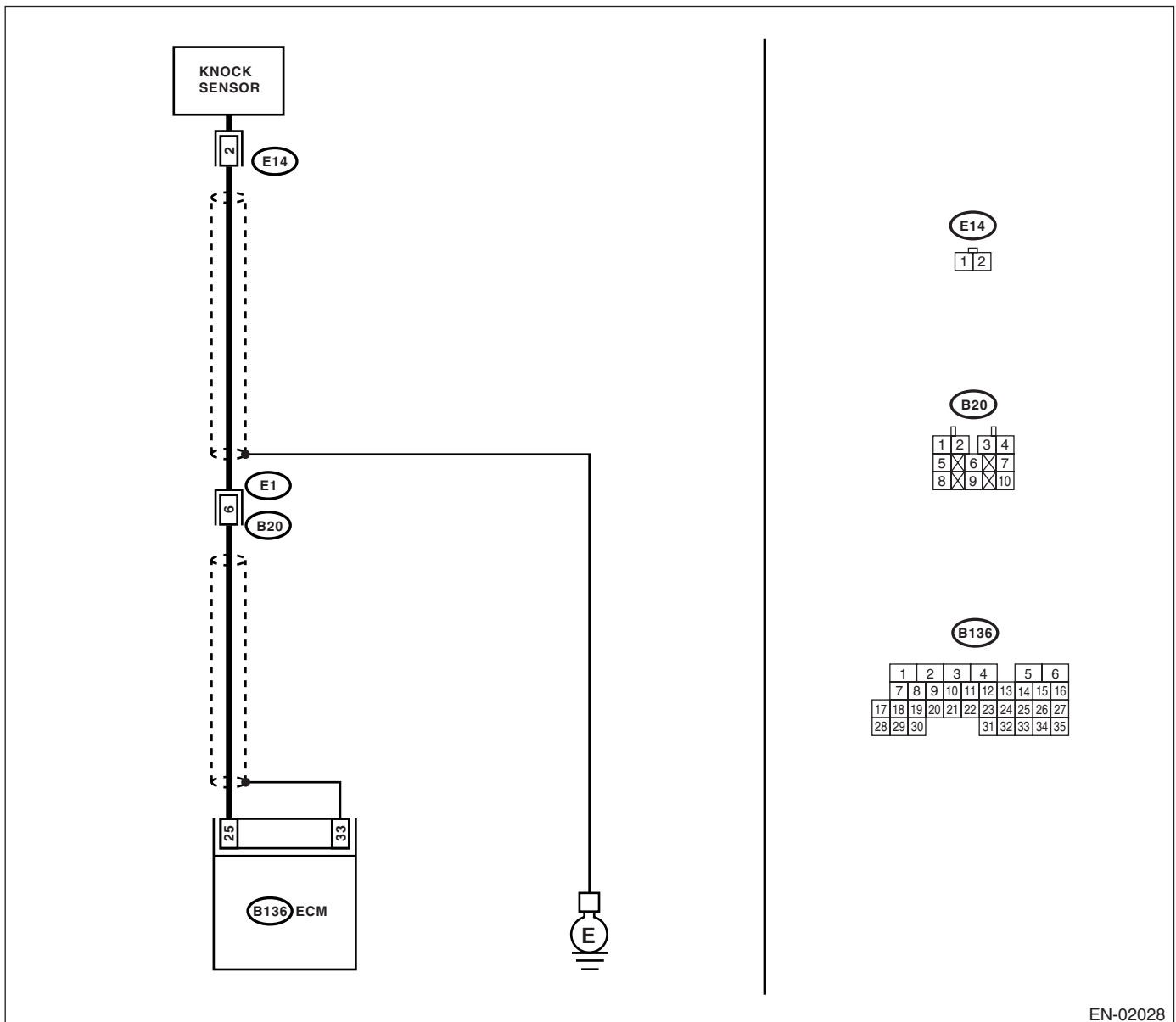

EN-02028

DIAGNOSTIC PROCEDURE WITH DIAGNOSTIC TROUBLE CODE (DTC)

ENGINE (DIAGNOSTICS)

Step	Check	Yes	No
1 CHECK HARNESS BETWEEN KNOCK SENSOR AND ECM CONNECTOR. Measure the resistance of harness between ECM connector and chassis ground. <i>Connector & terminal</i> <i>(B136) No. 25 — Chassis ground:</i>	Is the resistance less than 400 k Ω ?	Go to step 2.	Go to step 3.
2 CHECK KNOCK SENSOR. 1) Disconnect the connector from knock sensor. 2) Measure the resistance between knock sensor connector terminal and engine ground. <i>Terminals</i> <i>No. 2 — Engine ground:</i>	Is the resistance less than 400 k Ω ?	Replace the knock sensor. <Ref. to FU(H4DOTC)-29, Knock Sensor.>	Repair the ground short circuit in harness between knock sensor connector and ECM connector. NOTE: The harness between both connectors is shielded. Repair the short circuit of harness together with shield.
3 CHECK INPUT SIGNAL FOR ECM. 1) Connect the connectors to ECM and knock sensor. 2) Turn the ignition switch to ON. 3) Measure the voltage between ECM and chassis ground. <i>Connector & terminal</i> <i>(B136) No. 25 (+) — Chassis ground (-):</i>	Is the voltage more than 2 V?	Even if malfunction indicator light lights up, the circuit has returned to a normal condition at this time. (However, the possibility of poor contact still remains.) NOTE: In this case, repair the following: <ul style="list-style-type: none"> • Poor contact in knock sensor connector • Poor contact in ECM connector • Poor contact in coupling connector 	Repair the poor contact in ECM connector.

DIAGNOSTIC PROCEDURE WITH DIAGNOSTIC TROUBLE CODE (DTC)

ENGINE (DIAGNOSTICS)

AV:DTC P0335 — CRANKSHAFT POSITION SENSOR “A” CIRCUIT —

DTC DETECTING CONDITION:

- Immediately at fault recognition
- GENERAL DESCRIPTION <Ref. to GD(H4DOTC)-107, DTC P0335 — CRANKSHAFT POSITION SENSOR “A” CIRCUIT —, Diagnostic Trouble Code (DTC) Detecting Criteria.>

TROUBLE SYMPTOM:

- Engine stalls.
- Failure of engine to start

CAUTION:

After repair or replacement of faulty parts, conduct Clear Memory Mode <Ref. to EN(H4DOTC)-44, OPERATION, Clear Memory Mode.> and Inspection Mode <Ref. to EN(H4DOTC)-36, OPERATION, Inspection Mode.>.

WIRING DIAGRAM:

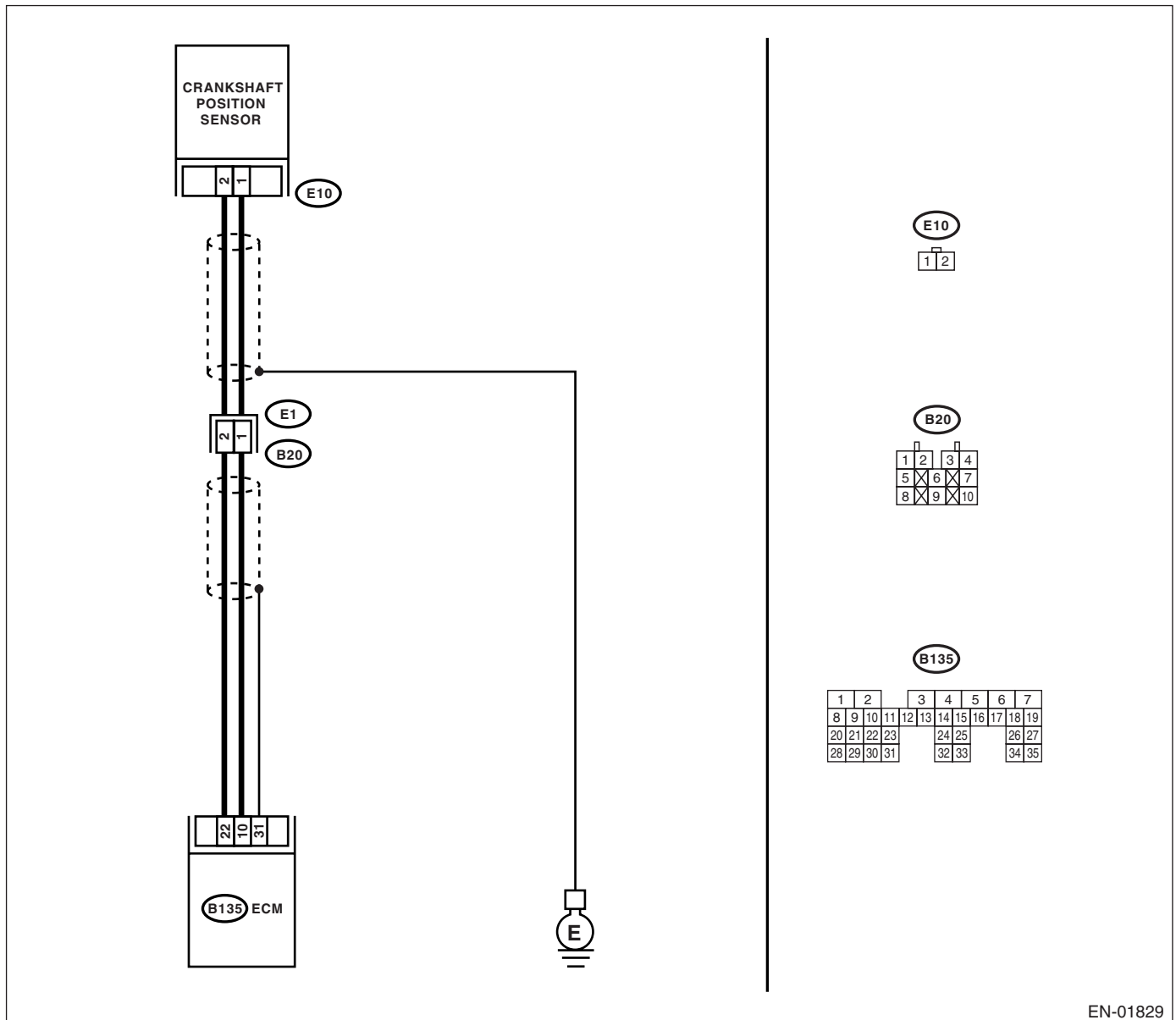

EN-01829

DIAGNOSTIC PROCEDURE WITH DIAGNOSTIC TROUBLE CODE (DTC)

ENGINE (DIAGNOSTICS)

Step	Check	Yes	No
<p>1</p> <p>CHECK HARNESS BETWEEN CRANKSHAFT POSITION SENSOR AND ECM CONNECTOR.</p> <p>1) Turn the ignition switch to OFF. 2) Disconnect the connector from crankshaft position sensor. 3) Measure the resistance of harness between crankshaft position sensor connector and engine ground.</p> <p>Connector & terminal (E10) No. 1 — Engine ground:</p>	<p>Is the resistance more than 100 kΩ?</p>	<p>Repair the harness and connector.</p> <p>NOTE: In this case, repair the following:</p> <ul style="list-style-type: none"> • Open circuit in harness between crankshaft position sensor and ECM connector • Poor contact in ECM connector • Poor contact in coupling connector 	<p>Go to step 2.</p>
<p>2</p> <p>CHECK HARNESS BETWEEN CRANKSHAFT POSITION SENSOR AND ECM CONNECTOR.</p> <p>Measure the resistance of harness between crankshaft position sensor connector and engine ground.</p> <p>Connector & terminal (E10) No. 1 — Engine ground:</p>	<p>Is the resistance more than 1 MΩ?</p>	<p>Go to step 3.</p>	<p>Repair the ground short circuit in harness between crankshaft position sensor and ECM connector.</p> <p>NOTE: The harness between both connectors are shielded. Repair ground short circuit in harness together with shield.</p>
<p>3</p> <p>CHECK HARNESS BETWEEN CRANKSHAFT POSITION SENSOR AND ECM CONNECTOR.</p> <p>Measure the resistance of harness between crankshaft position sensor connector and engine ground.</p> <p>Connector & terminal (E10) No. 2 — Engine ground:</p>	<p>Is the resistance less than 5 Ω?</p>	<p>Go to step 4.</p>	<p>Repair the harness and connector.</p> <p>NOTE: In this case, repair the following:</p> <ul style="list-style-type: none"> • Open circuit in harness between crankshaft position sensor and ECM connector • Poor contact in ECM connector • Poor contact in coupling connector
<p>4</p> <p>CHECK CONDITION OF CRANKSHAFT POSITION SENSOR.</p>	<p>Is the crankshaft position sensor installation bolt tightened securely?</p>	<p>Go to step 5.</p>	<p>Tighten the crankshaft position sensor installation bolt securely.</p>
<p>5</p> <p>CHECK CRANKSHAFT POSITION SENSOR.</p> <p>1) Remove the crankshaft position sensor. 2) Measure the resistance between connector terminals of crankshaft position sensor.</p> <p>Terminals No. 1 — No. 2:</p>	<p>Is the resistance 1 — 4 kΩ?</p>	<p>Repair the poor contact in crankshaft position sensor connector.</p>	<p>Replace the crankshaft position sensor. <Ref. to FU(H4DOTC)-27, Crankshaft Position Sensor.></p>

DIAGNOSTIC PROCEDURE WITH DIAGNOSTIC TROUBLE CODE (DTC)

ENGINE (DIAGNOSTICS)

AW:DTC P0336 — CRANKSHAFT POSITION SENSOR “A” CIRCUIT RANGE/ PERFORMANCE —

DTC DETECTING CONDITION:

- Two consecutive driving cycles with fault
- GENERAL DESCRIPTION <Ref. to GD(H4DOTC)-109, DTC P0336 — CRANKSHAFT POSITION SENSOR “A” CIRCUIT RANGE/PERFORMANCE —, Diagnostic Trouble Code (DTC) Detecting Criteria.>

TROUBLE SYMPTOM:

- Engine stalls.
- Failure of engine to start

CAUTION:

After repair or replacement of faulty parts, conduct Clear Memory Mode <Ref. to EN(H4DOTC)-44, OPERATION, Clear Memory Mode.> and Inspection Mode <Ref. to EN(H4DOTC)-36, OPERATION, Inspection Mode.>.

WIRING DIAGRAM:

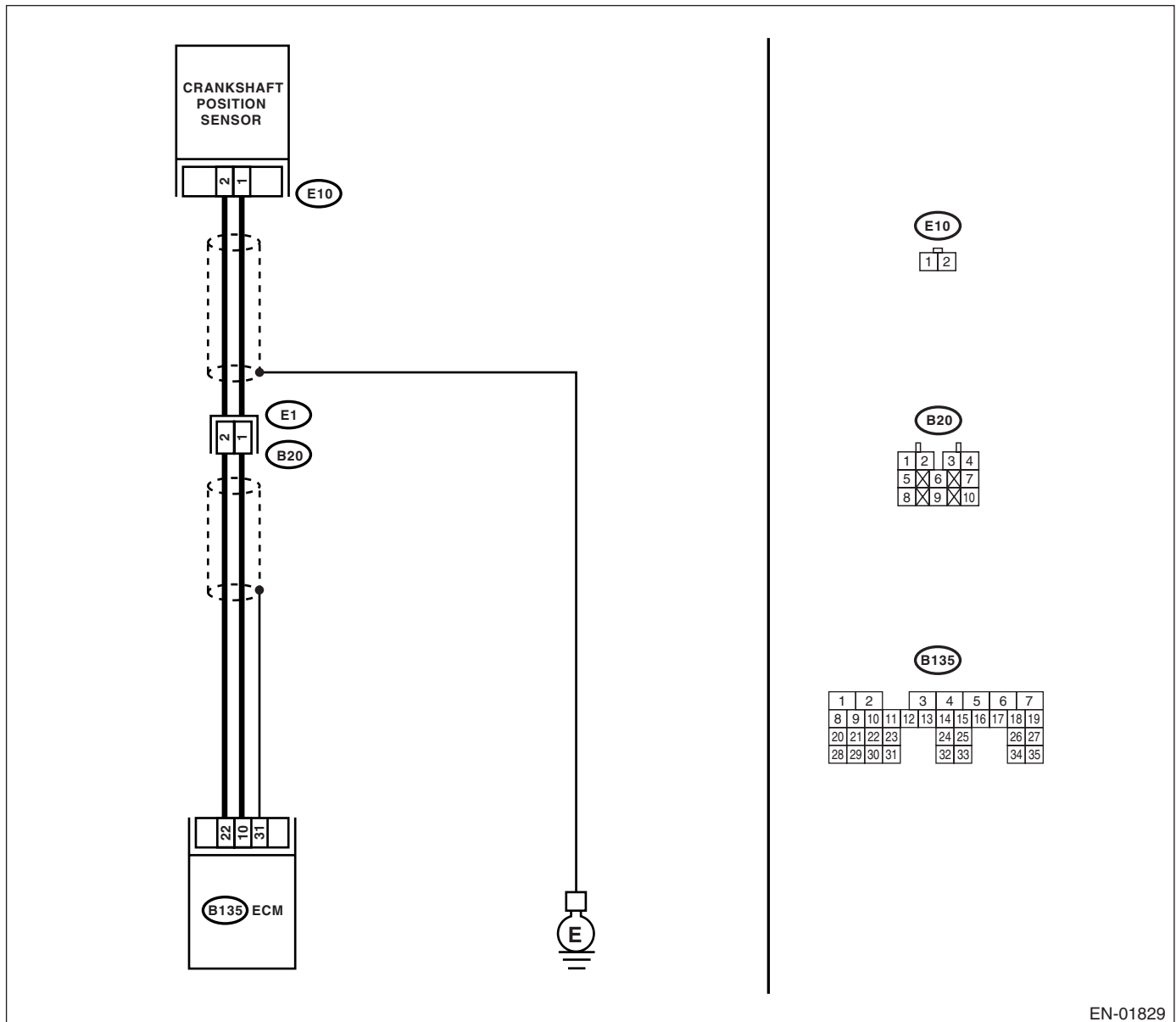

EN-01829

DIAGNOSTIC PROCEDURE WITH DIAGNOSTIC TROUBLE CODE (DTC)

ENGINE (DIAGNOSTICS)

Step	Check	Yes	No	
1	CHECK ANY OTHER DTC ON DISPLAY.	Is any other DTC displayed?	Inspect the relevant DTC using "List of Diagnostic Trouble Code (DTC)". <Ref. to EN(H4DOTC)-68, List of Diagnostic Trouble Code (DTC).>	Go to step 2.
2	CHECK CONDITION OF CRANKSHAFT POSITION SENSOR. Turn the ignition switch to OFF.	Is the crankshaft position sensor installation bolt tightened securely?	Go to step 3.	Tighten the crankshaft position sensor installation bolt securely.
3	CHECK CRANK SPROCKET. Remove the front belt cover.	Are the crank sprocket teeth cracked or damaged?	Replace the crank sprocket. <Ref. to FU(H4DOTC)-27, Crankshaft Position Sensor.>	Go to step 4.
4	CHECK INSTALLATION CONDITION OF TIMING BELT. Turn the crankshaft, and align alignment mark on crank sprocket with alignment mark on cylinder block.	Is the timing belt dislocated from its proper position?	Repair the installation condition of timing belt. <Ref. to ME(H4DOTC)-50, Timing Belt Assembly.>	Replace the crankshaft position sensor. <Ref. to FU(H4DOTC)-27, Crankshaft Position Sensor.>

DIAGNOSTIC PROCEDURE WITH DIAGNOSTIC TROUBLE CODE (DTC)

ENGINE (DIAGNOSTICS)

AX:DTC P0340 — CAMSHAFT POSITION SENSOR “A” CIRCUIT (BANK 1 OR SINGLE SENSOR) —

DTC DETECTING CONDITION:

- Immediately at fault recognition
- GENERAL DESCRIPTION <Ref. to GD(H4DOTC)-111, DTC P0340 — CAMSHAFT POSITION SENSOR “A” CIRCUIT (BANK 1 OR SINGLE SENSOR) —, Diagnostic Trouble Code (DTC) Detecting Criteria.>

TROUBLE SYMPTOM:

- Engine stalls.
- Failure of engine to start

CAUTION:

After repair or replacement of faulty parts, conduct Clear Memory Mode <Ref. to EN(H4DOTC)-44, OPERATION, Clear Memory Mode.> and Inspection Mode <Ref. to EN(H4DOTC)-36, OPERATION, Inspection Mode.>.

WIRING DIAGRAM:

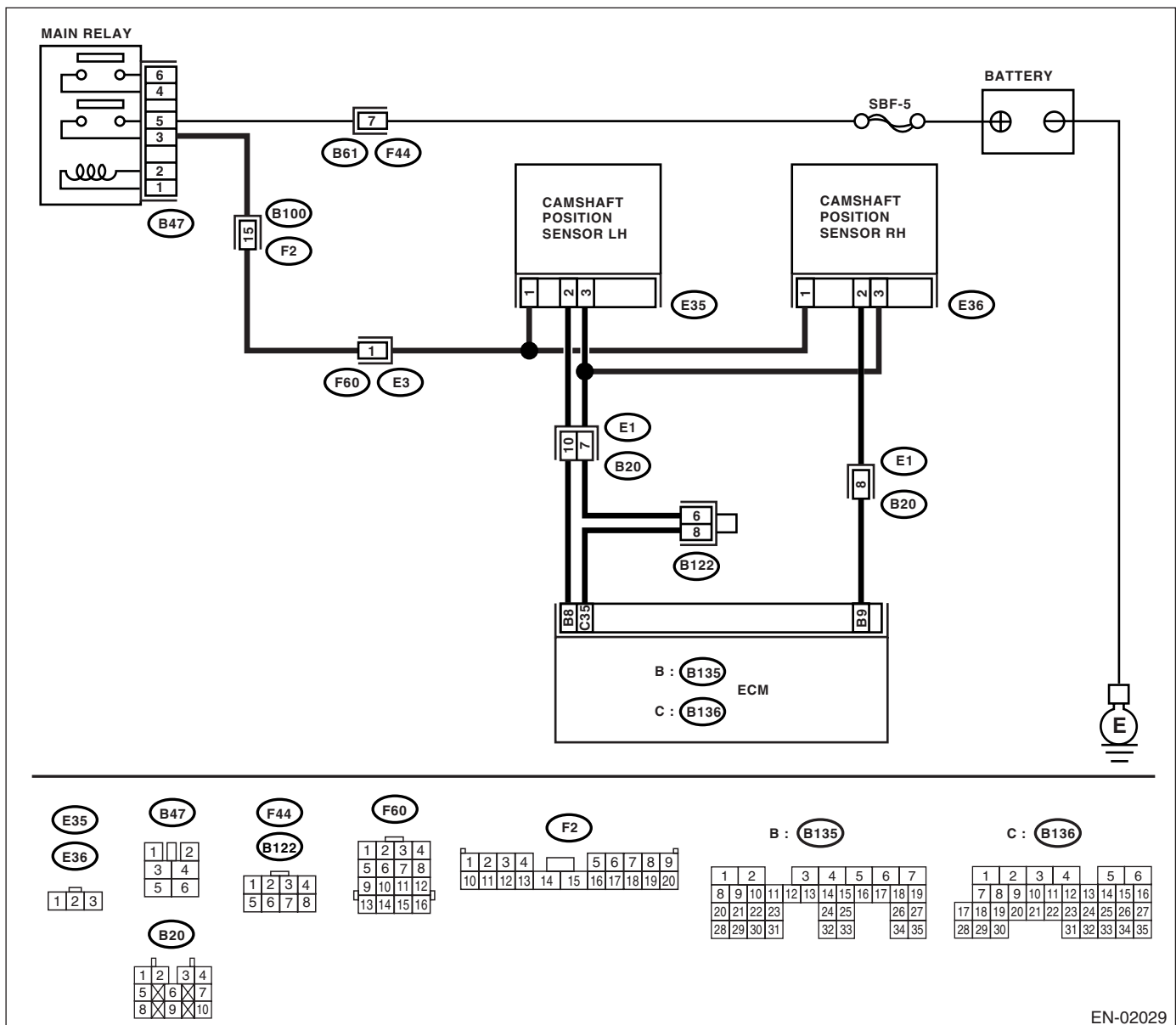

EN-02029

DIAGNOSTIC PROCEDURE WITH DIAGNOSTIC TROUBLE CODE (DTC)

ENGINE (DIAGNOSTICS)

Step	Check	Yes	No
1 CHECK POWER SUPPLY TO CAMSHAFT POSITION SENSOR. 1) Turn the ignition switch to OFF. 2) Disconnect the connector from camshaft position sensor. 3) Measure the voltage between camshaft position sensor and engine ground. <i>Connector & terminal</i> <i>(E36) No. 1 (+) — Engine ground (-):</i>	Is the voltage more than 10 V?	Repair the ground short circuit between main relay connector and camshaft position sensor connector.	Go to step 2.
2 CHECK POWER SUPPLY TO CAMSHAFT POSITION SENSOR. 1) Turn the ignition switch to ON. 2) Measure the voltage between camshaft position sensor and engine ground. <i>Connector & terminal</i> <i>(E36) No. 1 (+) — Engine ground (-):</i>	Is the voltage more than 10 V?	Go to step 3.	Repair the open or ground short circuit between main relay connector and camshaft position sensor connector.
3 CHECK HARNESS BETWEEN CAMSHAFT POSITION SENSOR AND ECM. 1) Turn the ignition switch to OFF. 2) Disconnect the connector from ECM. 3) Measure the resistance between camshaft position sensor and ECM. <i>Connector & terminal</i> <i>(E36) No. 2 — (B135) No. 9:</i> <i>(E35) No. 3 — (B136) No. 35:</i>	Is the resistance less than 1 Ω ?	Go to step 4.	Repair the open circuit between camshaft position sensor and ECM.
4 CHECK HARNESS BETWEEN CAMSHAFT POSITION SENSOR AND ECM. Measure the resistance between camshaft position sensor and engine ground. <i>Connector & terminal</i> <i>(E36) No. 2 — Engine ground:</i> <i>(E35) No. 3 — Engine ground:</i>	Is the resistance more than 1 M Ω ?	Go to step 5.	Repair the ground short circuit between camshaft position sensor and ECM.
5 CHECK CONDITION OF CAMSHAFT POSITION SENSOR.	Is the camshaft position sensor installation bolt tightened securely?	Go to step 6.	Tighten the camshaft position sensor installation bolt securely.
6 CHECK CAMSHAFT POSITION SENSOR. Check the camshaft position sensor waveform. <Ref. to EN(H4DOTC)-19, Engine Control Module (ECM) I/O Signal.>	Is any abnormality found in waveform?	Replace the camshaft position sensor. <Ref. to FU(H4DOTC)-28, Camshaft Position Sensor.>	Go to step 7.
7 CHECK POOR CONTACT. Check poor contact in ECM connector.	Is there poor contact in ECM connector?	Repair the poor contact in ECM connector.	Replace the ECM. <Ref. to FU(H4DOTC)-42, Engine Control Module (ECM).>

DIAGNOSTIC PROCEDURE WITH DIAGNOSTIC TROUBLE CODE (DTC)

ENGINE (DIAGNOSTICS)

AY:DTC P0345 — CAMSHAFT POSITION SENSOR “A” CIRCUIT (BANK 2) —

DTC DETECTING CONDITION:

- Immediately at fault recognition
- GENERAL DESCRIPTION <Ref. to GD(H4DOTC)-113, DTC P0345 — CAMSHAFT POSITION SENSOR “A” CIRCUIT (BANK 2) —, Diagnostic Trouble Code (DTC) Detecting Criteria.>

TROUBLE SYMPTOM:

- Engine stalls.
- Failure of engine to start

CAUTION:

After repair or replacement of faulty parts, conduct Clear Memory Mode <Ref. to EN(H4DOTC)-44, OPERATION, Clear Memory Mode.> and Inspection Mode <Ref. to EN(H4DOTC)-36, OPERATION, Inspection Mode.>.

WIRING DIAGRAM:

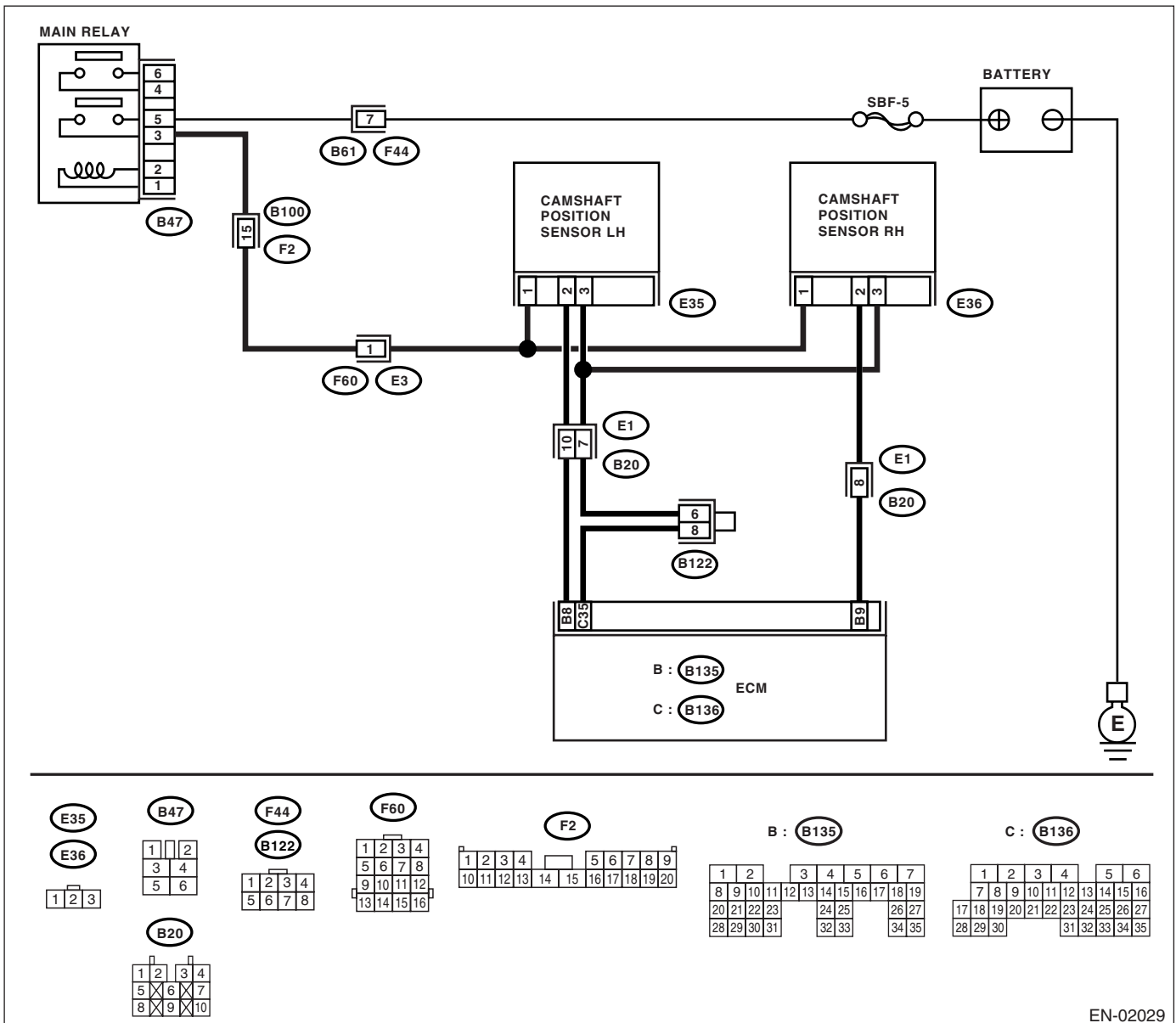

EN-02029

DIAGNOSTIC PROCEDURE WITH DIAGNOSTIC TROUBLE CODE (DTC)

ENGINE (DIAGNOSTICS)

Step	Check	Yes	No
1 CHECK POWER SUPPLY TO CAMSHAFT POSITION SENSOR. 1) Turn the ignition switch to OFF. 2) Disconnect the connector from camshaft position sensor. 3) Measure the voltage between camshaft position sensor and engine ground. <i>Connector & terminal</i> <i>(E35) No. 1 (+) — Engine ground (-):</i>	Is the voltage more than 10 V?	Repair the battery short circuit between main relay connector and camshaft position sensor connector.	Go to step 2.
2 CHECK POWER SUPPLY TO CAMSHAFT POSITION SENSOR. 1) Turn the ignition switch to ON. 2) Measure the voltage between camshaft position sensor and engine ground. <i>Connector & terminal</i> <i>(E35) No. 1 (+) — Engine ground (-):</i>	Is the voltage more than 10 V?	Go to step 3.	Repair the open or ground short circuit between main relay connector and camshaft position sensor connector.
3 CHECK HARNESS BETWEEN CAMSHAFT POSITION SENSOR AND ECM. 1) Turn the ignition switch to OFF. 2) Disconnect the connector from ECM. 3) Measure the resistance between camshaft position sensor and ECM. <i>Connector & terminal</i> <i>(E35) No. 2 — (B135) No. 8:</i> <i>(E35) No. 3 — (B136) No. 35:</i>	Is the resistance less than 1 Ω ?	Go to step 4.	Repair the open circuit between camshaft position sensor and ECM.
4 CHECK HARNESS BETWEEN CAMSHAFT POSITION SENSOR AND ECM. Measure the resistance between camshaft position sensor and engine ground. <i>Connector & terminal</i> <i>(E35) No. 2 — Engine ground:</i> <i>(E35) No. 3 — Engine ground:</i>	Is the resistance more than 1 M Ω ?	Go to step 5.	Repair the ground short circuit between camshaft position sensor and ECM.
5 CHECK CONDITION OF CAMSHAFT POSITION SENSOR.	Is the camshaft position sensor installation bolt tightened securely?	Go to step 6.	Tighten the camshaft position sensor installation bolt securely.
6 CHECK CAMSHAFT POSITION SENSOR. Check the camshaft position sensor waveform. <Ref. to EN(H4DOTC)-19, Engine Control Module (ECM) I/O Signal.>	Is any abnormality found in waveform?	Replace the camshaft position sensor. <Ref. to FU(H4DOTC)-28, Camshaft Position Sensor.>	Go to step 7.
7 CHECK POOR CONTACT. Check poor contact in ECM connector.	Is there poor contact in ECM connector?	Repair the poor contact in ECM connector.	Replace the ECM. <Ref. to FU(H4DOTC)-42, Engine Control Module (ECM).>

DIAGNOSTIC PROCEDURE WITH DIAGNOSTIC TROUBLE CODE (DTC)

ENGINE (DIAGNOSTICS)

AZ:DTC P0420 — CATALYST SYSTEM EFFICIENCY BELOW THRESHOLD (BANK 1) —

DTC DETECTING CONDITION:

- Two consecutive driving cycles with fault
- GENERAL DESCRIPTION <Ref. to GD(H4DOTC)-114, DTC P0420 — CATALYST SYSTEM EFFICIENCY BELOW THRESHOLD (BANK 1) —, Diagnostic Trouble Code (DTC) Detecting Criteria.>

TROUBLE SYMPTOM:

- Engine stalls.
- Idle mixture is out of specifications.

CAUTION:

After repair or replacement of faulty parts, conduct Clear Memory Mode <Ref. to EN(H4DOTC)-44, OPERATION, Clear Memory Mode.> and Inspection Mode <Ref. to EN(H4DOTC)-36, OPERATION, Inspection Mode.>.

WIRING DIAGRAM:

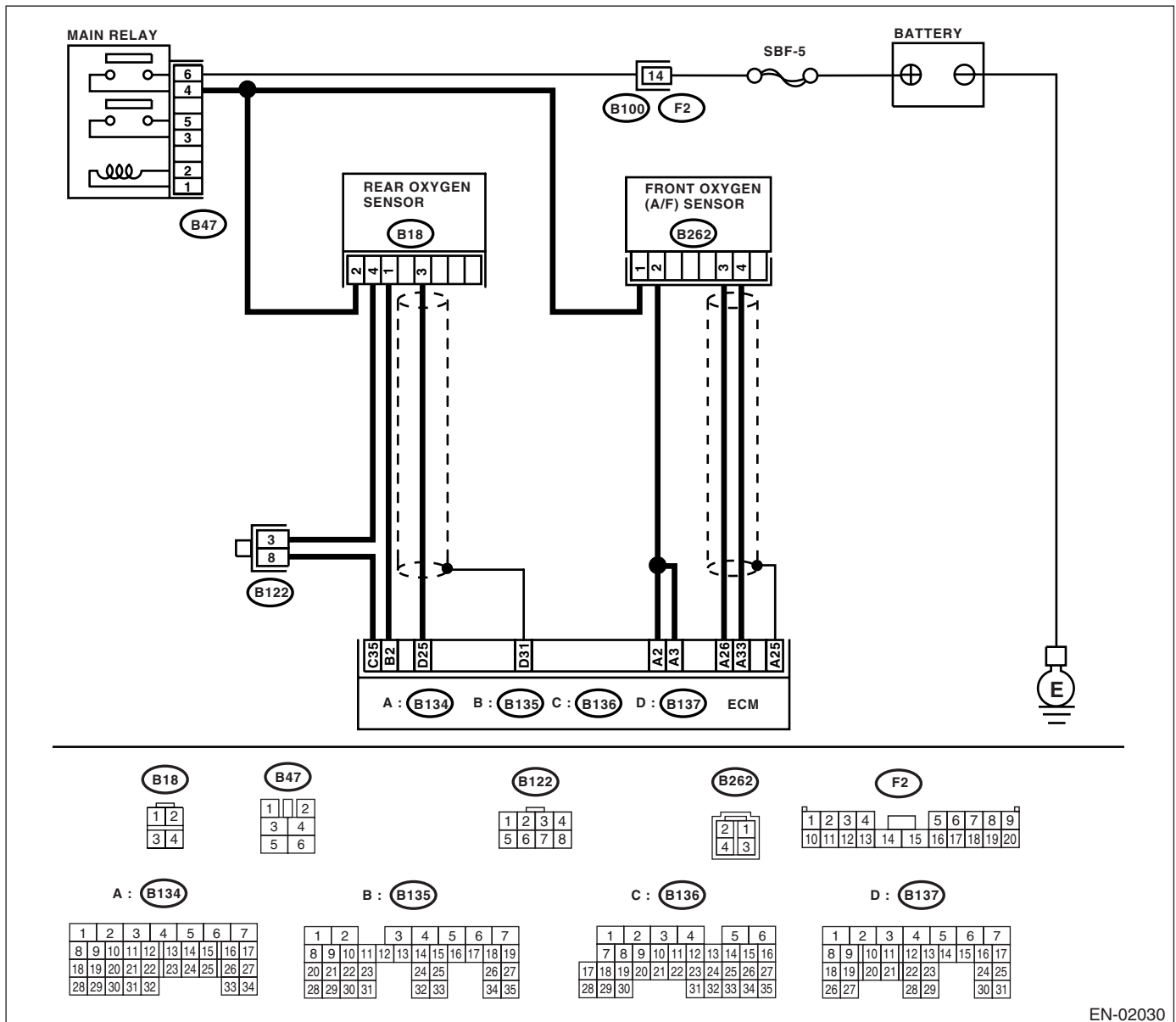

EN-02030

DIAGNOSTIC PROCEDURE WITH DIAGNOSTIC TROUBLE CODE (DTC)

ENGINE (DIAGNOSTICS)

Step	Check	Yes	No
1	CHECK ANY OTHER DTC ON DISPLAY.	Is any other DTC displayed?	Inspect the relevant DTC using "List of Diagnostic Trouble Code (DTC)". <Ref. to EN(H4DOTC)-68, List of Diagnostic Trouble Code (DTC).> NOTE: In this case, it is not necessary to inspect DTC P0420.
2	CHECK EXHAUST SYSTEM. Check for gas leaks or air suction caused by loose or dislocated nuts and bolts, and open hole at exhaust pipes. NOTE: Check the following positions. <ul style="list-style-type: none"> • Between cylinder head and front exhaust pipe • Between front exhaust pipe and front catalytic converter • Between front catalytic converter and rear catalytic converter 	Is there a fault in exhaust system?	Repair or replace the exhaust system. <Ref. to EX(H4DOTC)-2, General Description.>
3	CHECK REAR CATALYTIC CONVERTER. Separate the rear catalytic converter from rear exhaust pipe.	Is there damage at rear face of rear catalyst?	Replace the front catalytic converter. <Ref. to EC(H4DOTC)-3, Front Catalytic Converter.> and rear catalytic converter <Ref. to EC(H4DOTC)-4, Rear Catalytic Converter.>
4	CHECK FRONT CATALYTIC CONVERTER. Remove the front catalytic converter.	Is there damage at rear face or front face of front catalyst?	Replace the front catalytic converter. <Ref. to EC(H4DOTC)-3, Front Catalytic Converter.> NOTE: Inspection by DTM is required, because probable cause is deterioration of multiple parts.

DIAGNOSTIC PROCEDURE WITH DIAGNOSTIC TROUBLE CODE (DTC)

ENGINE (DIAGNOSTICS)

BA:DTC P0442 — EVAPORATIVE EMISSION CONTROL SYSTEM LEAK DETECTED (SMALL LEAK) —

DTC DETECTING CONDITION:

- Two consecutive driving cycles with fault
- GENERAL DESCRIPTION <Ref. to GD(H4DOTC)-117, DTC P0442 — EVAPORATIVE EMISSION CONTROL SYSTEM LEAK DETECTED (SMALL LEAK) —, Diagnostic Trouble Code (DTC) Detecting Criteria.>

TROUBLE SYMPTOM:

- Fuel odor
- There is a hole of more than 1.0 mm (0.04 in) dia. in evaporation system or fuel tank.

CAUTION:

After repair or replacement of faulty parts, conduct Clear Memory Mode <Ref. to EN(H4DOTC)-44, OPERATION, Clear Memory Mode.> and Inspection Mode <Ref. to EN(H4DOTC)-36, OPERATION, Inspection Mode.>.

DIAGNOSTIC PROCEDURE WITH DIAGNOSTIC TROUBLE CODE (DTC)

ENGINE (DIAGNOSTICS)

WIRING DIAGRAM:

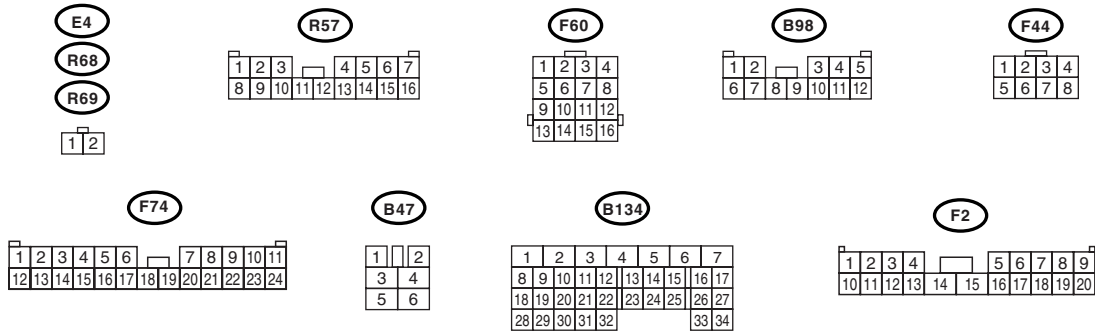
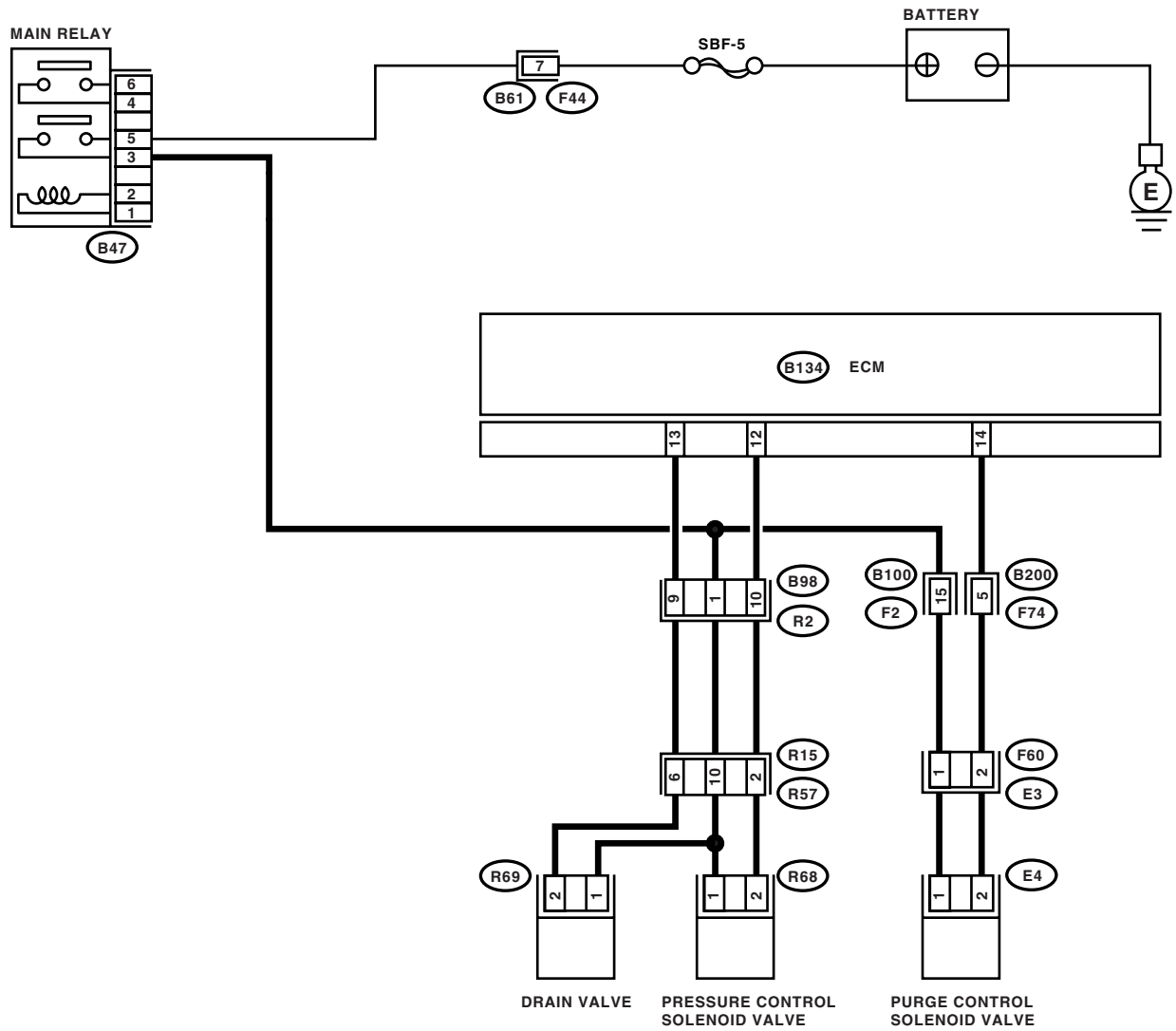

EN-02031

DIAGNOSTIC PROCEDURE WITH DIAGNOSTIC TROUBLE CODE (DTC)

ENGINE (DIAGNOSTICS)

Step	Check	Yes	No
1	CHECK FOR OTHER DTC ON DISPLAY.	Is any other DTC displayed?	Inspect the relevant DTC using "List of Diagnostic Trouble Code (DTC)". <Ref. to EN(H4DOTC)-68, List of Diagnostic Trouble Code (DTC).>
2	CHECK FUEL FILLER CAP. 1) Turn ignition switch to OFF. 2) Check the fuel filler cap. NOTE: The DTC is stored in memory if fuel filler cap is or was loose or if the cap chain was caught while tightening.	Is the fuel filler cap tightened securely?	Go to step 3. Tighten fuel filler cap securely.
3	CHECK FUEL FILLER CAP.	Is the fuel filler cap SUBARU genuine?	Go to step 4. Replace with a SUBARU genuine fuel filler cap.
4	CHECK FUEL FILLER PIPE PACKING.	Is there any damage to the seal between fuel filler cap and fuel filler pipe?	Repair or replace the fuel filler cap and fuel filler pipe. <Ref. to FU(H4DOTC)-50, Fuel Filler Pipe.>
5	CHECK DRAIN VALVE. 1) Connect the test mode connector. 2) Turn ignition switch to ON. 3) Operate the drain valve. NOTE: Drain valve operation can also be executed using Subaru Select Monitor. For the procedure, refer to "Compulsory Valve Operation Check Mode". <Ref. to EN(H4DOTC)-45, Compulsory Valve Operation Check Mode.>	Does the drain valve operate?	Go to step 6. Replace the drain valve. <Ref. to EC(H4DOTC)-19, Drain Valve.>
6	CHECK PURGE CONTROL SOLENOID VALVE. Operate the purge control solenoid valve. NOTE: Purge control solenoid valve operation can also be executed using Subaru Select Monitor. For the procedure, refer to "Compulsory Valve Operation Check Mode". <Ref. to EN(H4DOTC)-45, Compulsory Valve Operation Check Mode.>	Does the purge control solenoid valve operate?	Go to step 7. Replace the purge control solenoid valve. <Ref. to EC(H4DOTC)-7, Purge Control Solenoid Valve.>
7	CHECK PRESSURE CONTROL SOLENOID VALVE. Operate the pressure control solenoid valve. NOTE: Pressure control solenoid valve operation can also be executed using Subaru Select Monitor. For the procedure, refer to "Compulsory Valve Operation Check Mode". <Ref. to EN(H4DOTC)-45, Compulsory Valve Operation Check Mode.>	Does the pressure control solenoid valve operate?	Go to step 8. Replace the pressure control solenoid valve. <Ref. to EC(H4DOTC)-13, Pressure Control Solenoid Valve.>

DIAGNOSTIC PROCEDURE WITH DIAGNOSTIC TROUBLE CODE (DTC)

ENGINE (DIAGNOSTICS)

Step	Check	Yes	No	
8	CHECK EVAPORATIVE EMISSION CONTROL SYSTEM LINE. Turn ignition switch to OFF.	Is there a hole of more than 1.0 mm (0.04 in) dia. on evaporation line?	Repair or replace the evaporation line. <Ref. to FU(H4DOTC)-63, Fuel Delivery, Return and Evaporation Lines.>	Go to step 9 .
9	CHECK CANISTER.	Is the canister damaged or is there a hole of more than 1.0 mm (0.04 in) dia. in it?	Repair or replace the canister. <Ref. to EC(H4DOTC)-6, Canister.>	Go to step 10 .
10	CHECK FUEL TANK. Remove the fuel tank. <Ref. to FU(H4DOTC)-47, Fuel Tank.>	Is the fuel tank damaged or is there a hole of more than 1.0 mm (0.04 in) dia. in it?	Repair or replace the fuel tank. <Ref. to FU(H4DOTC)-47, Fuel Tank.>	Go to step 11 .
11	CHECK ANY OTHER MECHANICAL TROUBLE IN EVAPORATIVE EMISSION CONTROL SYSTEM.	Are there holes of more than 1.0 mm (0.04 in) dia., cracks, clogging, or disconnections, bend, misconnection of hoses or pipes in evaporative emission control system?	Repair or replace the hoses or pipes.	Contact with SOA Service Center. NOTE: Inspection by DTM is required, because probable cause is deterioration of multiple parts.

DIAGNOSTIC PROCEDURE WITH DIAGNOSTIC TROUBLE CODE (DTC)

ENGINE (DIAGNOSTICS)

BB:DTC P0447 — EVAPORATIVE EMISSION CONTROL SYSTEM VENT CONTROL CIRCUIT OPEN —

DTC DETECTING CONDITION:

- Two consecutive driving cycles with fault
- GENERAL DESCRIPTION <Ref. to GD(H4DOTC)-142, DTC P0447 — EVAPORATIVE EMISSION CONTROL SYSTEM VENT CONTROL CIRCUIT OPEN —, Diagnostic Trouble Code (DTC) Detecting Criteria.>

CAUTION:

After repair or replacement of faulty parts, conduct Clear Memory Mode <Ref. to EN(H4DOTC)-44, OPERATION, Clear Memory Mode.> and Inspection Mode <Ref. to EN(H4DOTC)-36, OPERATION, Inspection Mode.>.

WIRING DIAGRAM:

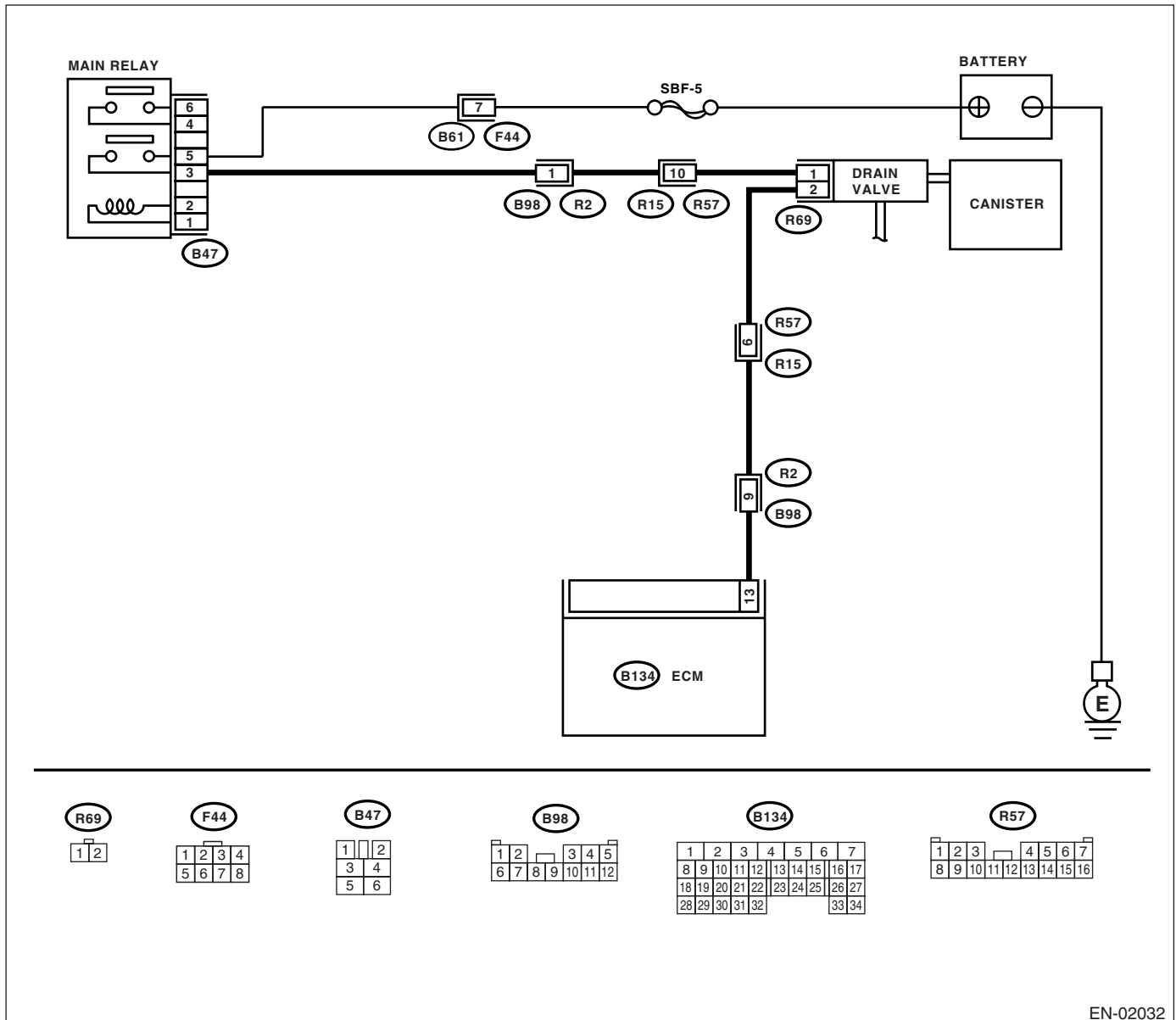

EN-02032

DIAGNOSTIC PROCEDURE WITH DIAGNOSTIC TROUBLE CODE (DTC)

ENGINE (DIAGNOSTICS)

Step	Check	Yes	No
1 CHECK OUTPUT SIGNAL FROM ECM. 1) Turn ignition switch to ON. 2) Measure the voltage between ECM and chassis ground. <i>Connector & terminal</i> <i>(B134) No. 13 (+) — Chassis ground (-):</i>	Is the voltage more than 10 V?	Go to step 2.	Go to step 3.
2 CHECK FOR POOR CONTACT. Check for poor contact in ECM connector.	Is there poor contact in ECM connector?	Repair poor contact in ECM connector.	The malfunction indicator light may light up, however, the circuit is returned to the normal status at the moment. (However, the possibility of poor contact still remains.) NOTE: In this case, repair the following: <ul style="list-style-type: none"> • Poor contact in drain valve connector • Poor contact in ECM connector • Poor contact in coupling connector
3 CHECK HARNESS BETWEEN DRAIN VALVE AND ECM CONNECTOR. 1) Turn ignition switch to OFF. 2) Disconnect the connectors from drain valve and ECM. 3) Measure the resistance of harness between drain valve connector and chassis ground. <i>Connector & terminal</i> <i>(R69) No. 2 — Chassis ground:</i>	Is the resistance more than 1 M Ω ?	Go to step 4.	Repair short circuit to ground in harness between ECM and drain valve connector.
4 CHECK HARNESS BETWEEN DRAIN VALVE AND ECM CONNECTOR. Measure the resistance of harness between ECM and drain valve connector. <i>Connector & terminal</i> <i>(B134) No. 13 — (R69) No. 2:</i>	Is the resistance less than 1 Ω ?	Go to step 5.	Repair harness and connector. NOTE: In this case, repair the following: <ul style="list-style-type: none"> • Open circuit in harness between ECM and drain valve connector • Poor contact in coupling connector
5 CHECK DRAIN VALVE. Measure the resistance between drain valve terminals. <i>Terminals</i> <i>No. 1 — No. 2:</i>	Is the resistance 10 — 100 Ω ?	Go to step 6.	Replace the drain valve. <Ref. to EC(H4DOTC)-19, Drain Valve.>

DIAGNOSTIC PROCEDURE WITH DIAGNOSTIC TROUBLE CODE (DTC)

ENGINE (DIAGNOSTICS)

Step	Check	Yes	No
<p>6 CHECK POWER SUPPLY TO DRAIN VALVE. 1) Turn ignition switch to ON. 2) Measure the voltage between drain valve and chassis ground. Connector & terminal (R69) No. 1 (+) — Chassis ground (-):</p>	<p>Is the voltage more than 10 V?</p>	<p>Go to step 7.</p>	<p>Repair harness and connector. NOTE: In this case, repair the following:</p> <ul style="list-style-type: none"> • Open circuit in harness between main relay and drain valve • Poor contact in coupling connector • Poor contact in main relay connector
<p>7 CHECK FOR POOR CONTACT. Check for poor contact in drain valve connector.</p>	<p>Is there poor contact in drain valve connector?</p>	<p>Repair poor contact in drain valve connector.</p>	<p>Contact with SOA Service Center. NOTE: Inspection by DTM is required, because probable cause is deterioration of multiple parts.</p>

BC:DTC P0448 — EVAPORATIVE EMISSION CONTROL SYSTEM VENT CONTROL CIRCUIT SHORTED —

DTC DETECTING CONDITION:

- Two consecutive driving cycles with fault
- GENERAL DESCRIPTION <Ref. to GD(H4DOTC)-144, DTC P0448 — EVAPORATIVE EMISSION CONTROL SYSTEM VENT CONTROL CIRCUIT SHORTED —, Diagnostic Trouble Code (DTC) Detecting Criteria.>

CAUTION:

After repair or replacement of faulty parts, conduct Clear Memory Mode <Ref. to EN(H4DOTC)-44, OPERATION, Clear Memory Mode.> and Inspection Mode <Ref. to EN(H4DOTC)-36, OPERATION, Inspection Mode.>

WIRING DIAGRAM:

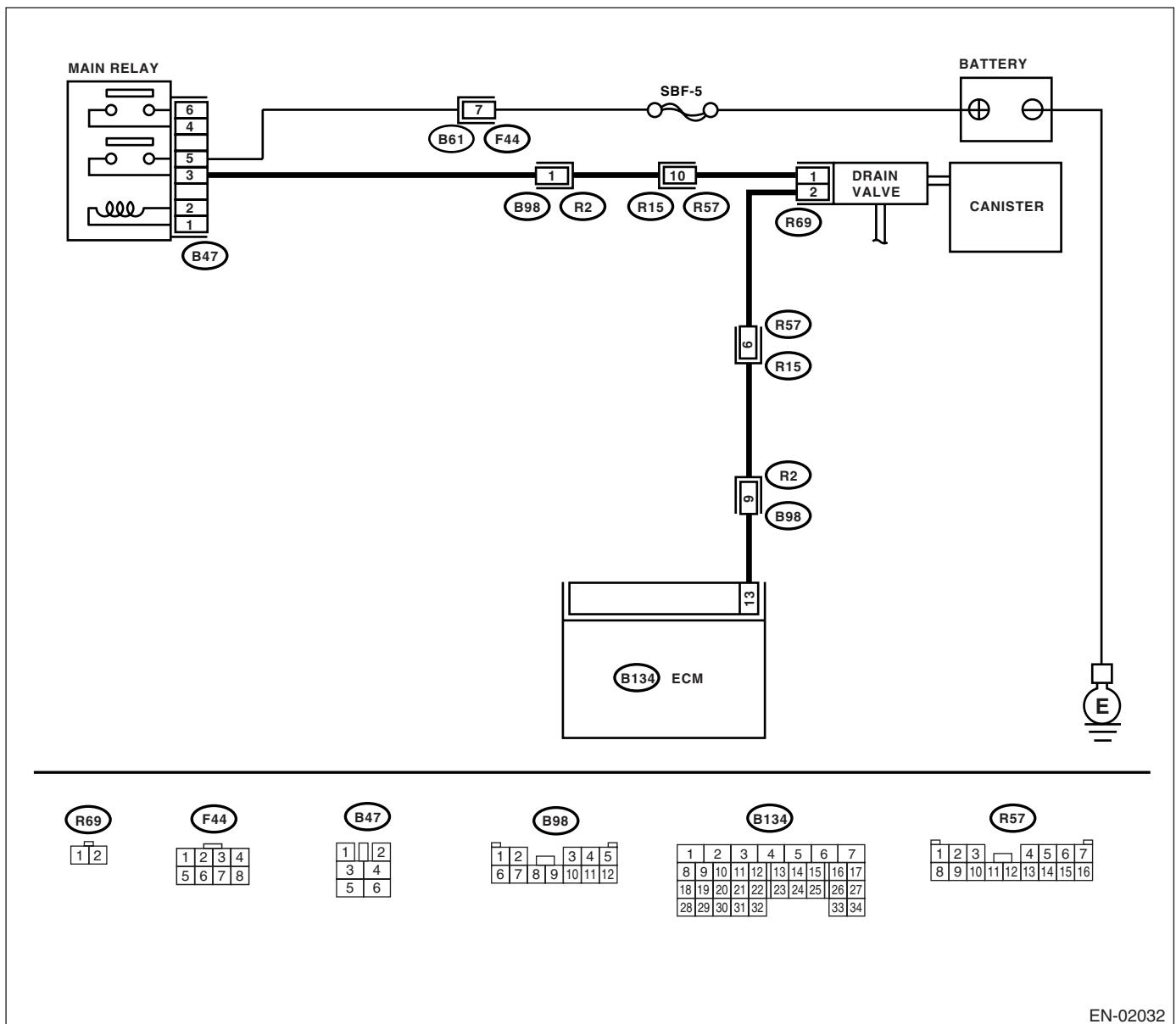

EN-02032

DIAGNOSTIC PROCEDURE WITH DIAGNOSTIC TROUBLE CODE (DTC)

ENGINE (DIAGNOSTICS)

Step	Check	Yes	No
1 CHECK INPUT SIGNAL FOR ECM. 1) Turn ignition switch to OFF. 2) Connect the test mode connector at the lower portion of instrument panel (on the driver's side). 3) Turn ignition switch to ON. 4) While operating the drain valve, measure voltage between ECM and chassis ground. NOTE: Drain valve operation can be executed using Subaru Select Monitor. For the procedure, refer to "Compulsory Valve Operation Check Mode". <Ref. to EN(H4DOTC)-45, Compulsory Valve Operation Check Mode.> Connector & terminal (B134) No. 13 (+) — Chassis ground (-):	Is the voltage 0 — 10 V?	Go to step 2.	The malfunction indicator light may light up, however, the circuit is returned to the normal status at the moment. In this case, repair poor contact in ECM connector.
2 CHECK INPUT SIGNAL FOR ECM. 1) Turn ignition switch to ON. 2) Measure the voltage between ECM and chassis ground. Connector & terminal (B134) No. 13 (+) — Chassis ground (-):	Is the voltage more than 10 V?	Go to step 4.	Go to step 3.
3 CHECK FOR POOR CONTACT. Check for poor contact in ECM connector.	Is there poor contact in ECM connector?	Repair poor contact in ECM connector.	Replace the ECM. <Ref. to FU(H4DOTC)-42, Engine Control Module (ECM).>
4 CHECK HARNESS BETWEEN DRAIN VALVE AND ECM CONNECTOR. 1) Turn ignition switch to OFF. 2) Disconnect the connector from drain valve. 3) Turn ignition switch to ON. 4) Measure the voltage between ECM and chassis ground. Connector & terminal (B134) No. 13 (+) — Chassis ground (-):	Is the voltage more than 10 V?	Repair short circuit to battery in harness between ECM and drain valve connector. After repair, replace the ECM. <Ref. to FU(H4DOTC)-42, Engine Control Module (ECM).>	Go to step 5.
5 CHECK DRAIN VALVE. 1) Turn ignition switch to OFF. 2) Measure the resistance between drain valve terminals. Terminals No. 1 — No. 2:	Is the resistance less than 1 Ω ?	Replace the drain valve <Ref. to EC(H4DOTC)-19, Drain Valve.> and ECM <Ref. to FU(H4DOTC)-42, Engine Control Module (ECM).>.	Go to step 6.
6 CHECK FOR POOR CONTACT. Check for poor contact in ECM connector.	Is there poor contact in ECM connector?	Repair poor contact in ECM connector.	Replace the ECM. <Ref. to FU(H4DOTC)-42, Engine Control Module (ECM).>

BD:DTC P0451 — EVAPORATIVE EMISSION CONTROL SYSTEM PRESSURE SENSOR RANGE/PERFORMANCE —

DTC DETECTING CONDITION:

- Two consecutive driving cycles with fault
- GENERAL DESCRIPTION <Ref. to GD(H4DOTC)-146, DTC P0451 — EVAPORATIVE EMISSION CONTROL SYSTEM PRESSURE SENSOR RANGE/PERFORMANCE —, Diagnostic Trouble Code (DTC) Detecting Criteria.>

CAUTION:

After repair or replacement of faulty parts, conduct Clear Memory Mode <Ref. to EN(H4DOTC)-44, OPERATION, Clear Memory Mode.> and Inspection Mode <Ref. to EN(H4DOTC)-36, OPERATION, Inspection Mode.>.

WIRING DIAGRAM:

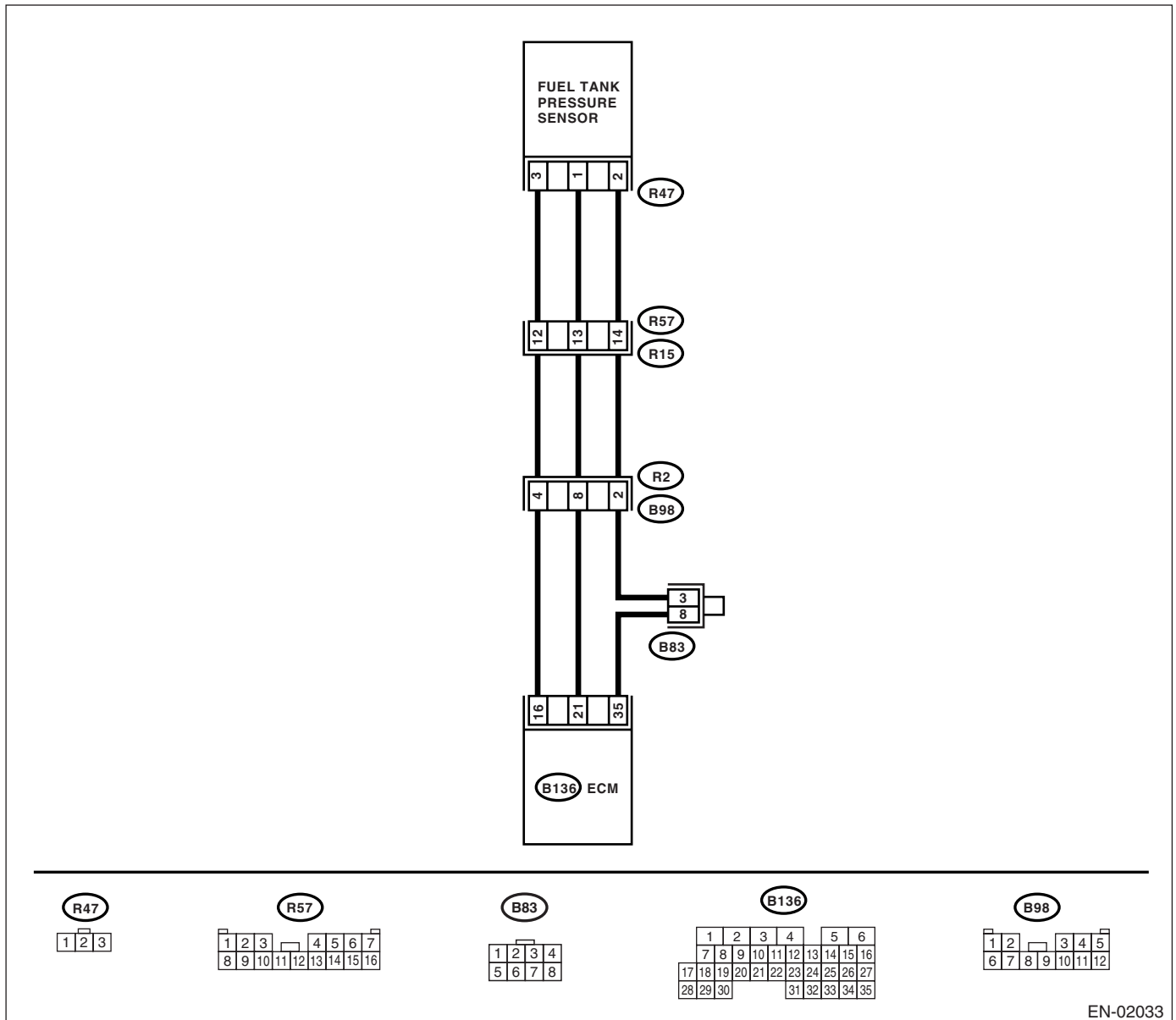

EN-02033

DIAGNOSTIC PROCEDURE WITH DIAGNOSTIC TROUBLE CODE (DTC)

ENGINE (DIAGNOSTICS)

Step	Check	Yes	No
1 CHECK FOR OTHER DTC ON DISPLAY.	Is any other DTC displayed?	Inspect the relevant DTC using "List of Diagnostic Trouble Code (DTC)". <Ref. to EN(H4DOTC)-68, List of Diagnostic Trouble Code (DTC).>	Go to step 2.
2 CHECK FUEL FILLER CAP. 1) Turn ignition switch to OFF. 2) Open the fuel flap.	Is the fuel filler cap tightened securely?	Go to step 3.	Tighten fuel filler cap securely.
3 CHECK PRESSURE/VACUUM LINE. NOTE: Check the following items. <ul style="list-style-type: none">• Disconnection, leakage and clogging of the vacuum hoses and pipes between fuel tank pressure sensor and fuel tank• Disconnection, leakage and clogging of air ventilation hoses and pipes between fuel filler pipe and fuel tank	Is there a fault in pressure/vacuum line?	Repair or replace the hoses and pipes.	Replace the fuel tank pressure sensor. <Ref. to EC(H4DOTC)-11, Fuel Tank Pressure Sensor.>

BE:DTC P0452 — EVAPORATIVE EMISSION CONTROL SYSTEM PRESSURE SENSOR LOW INPUT —

DTC DETECTING CONDITION:

- Two consecutive driving cycles with fault
- GENERAL DESCRIPTION <Ref. to GD(H4DOTC)-148, DTC P0452 — EVAPORATIVE EMISSION CONTROL SYSTEM PRESSURE SENSOR LOW INPUT —, Diagnostic Trouble Code (DTC) Detecting Criteria.>

CAUTION:

After repair or replacement of faulty parts, conduct Clear Memory Mode <Ref. to EN(H4DOTC)-44, OPERATION, Clear Memory Mode.> and Inspection Mode <Ref. to EN(H4DOTC)-36, OPERATION, Inspection Mode.>.

WIRING DIAGRAM:

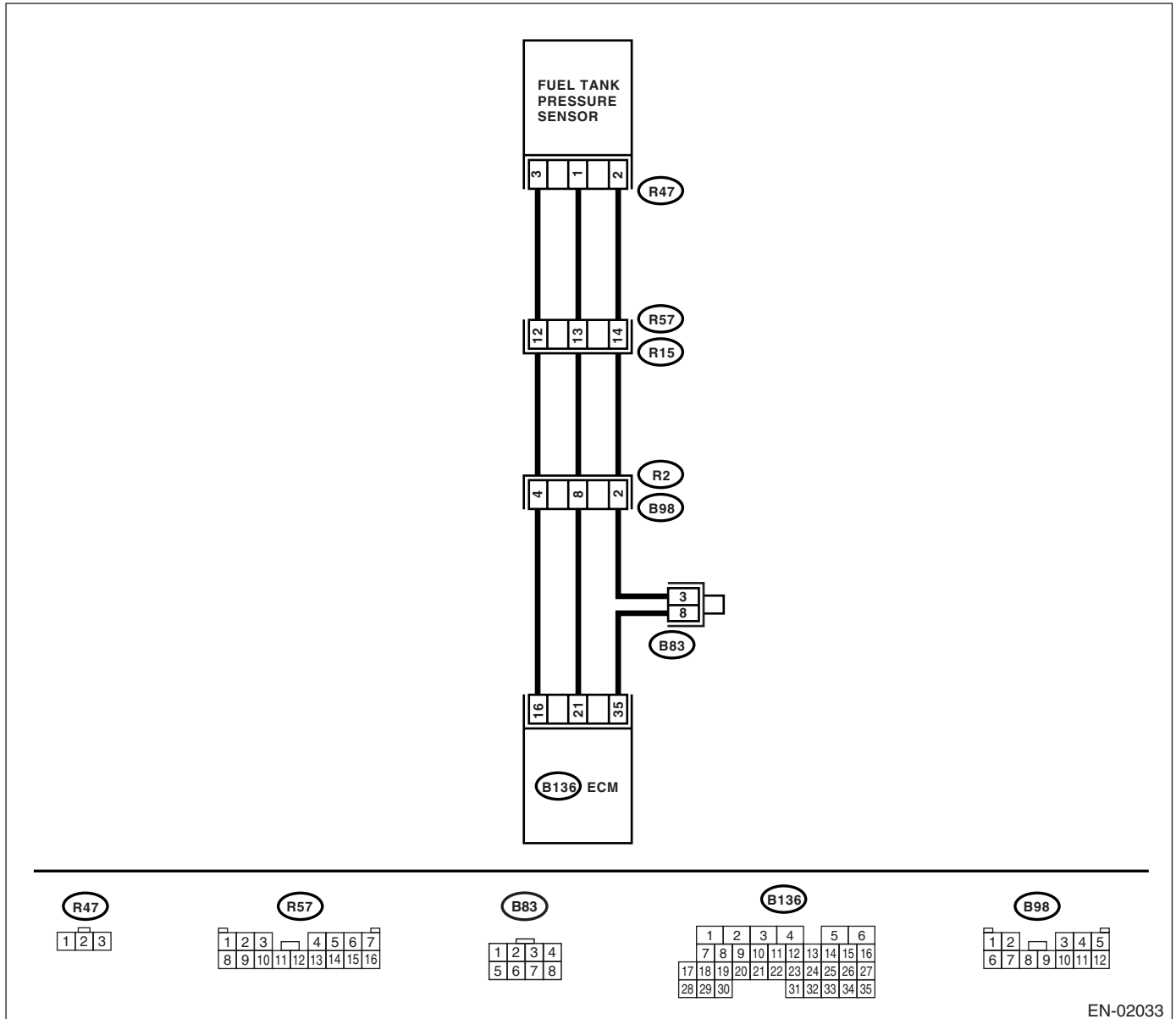

EN-02033

DIAGNOSTIC PROCEDURE WITH DIAGNOSTIC TROUBLE CODE (DTC)

ENGINE (DIAGNOSTICS)

Step	Check	Yes	No
<p>1 CHECK CURRENT DATA.</p> <ol style="list-style-type: none"> 1) Turn ignition switch to OFF. 2) Remove the fuel filler cap. 3) Install the fuel filler cap. 4) Turn ignition switch to ON. 5) Read the data of fuel tank pressure sensor signal using Subaru Select Monitor or the OBD-II general scan tool. <p>NOTE:</p> <ul style="list-style-type: none"> • Subaru Select Monitor <p>For detailed operation procedures, refer to "READ CURRENT DATA FOR ENGINE". <Ref. to EN(H4DOTC)-29, Subaru Select Monitor.></p> <ul style="list-style-type: none"> • OBD-II general scan tool <p>For detailed operation procedures, refer to the OBD-II General Scan Tool Instruction Manual.</p>	<p>Is the measured value less than -2.8 kPa (-21.0 mmHg, -0.827 inHg)?</p>	Go to step 2.	The malfunction indicator light may light up, however, the circuit is returned to the normal status at the moment.
<p>2 CHECK POWER SUPPLY TO FUEL TANK PRESSURE SENSOR.</p> <p>Measure the voltage between ECM connector and chassis ground.</p> <p>Connector & terminal (B136) No. 16 (+) — Chassis ground (-):</p>	Is the voltage more than 4.5 V?	Go to step 4.	Go to step 3.
<p>3 CHECK POWER SUPPLY TO FUEL TANK PRESSURE SENSOR.</p> <p>Measure the voltage between ECM connector and chassis ground.</p> <p>Connector & terminal (B136) No. 16 (+) — Chassis ground (-):</p>	Is the voltage more than 4.5 V?	Repair poor contact in ECM connector.	Contact with SOA Service Center. NOTE: Inspection by DTM is required, because probable cause is deterioration of multiple parts.
<p>4 CHECK INPUT SIGNAL FOR ECM.</p> <p>Measure the voltage between ECM and chassis ground.</p> <p>Connector & terminal (B136) No. 21 (+) — Chassis ground (-):</p>	Is the voltage less than 0.2 V?	Go to step 6.	Go to step 5.
<p>5 CHECK INPUT SIGNAL FOR ECM. (USING SUBARU SELECT MONITOR.)</p> <p>Read the data of fuel tank pressure sensor signal using Subaru Select Monitor.</p> <p>NOTE:</p> <ul style="list-style-type: none"> • Subaru Select Monitor <p>For detailed operation procedures, refer to "READ CURRENT DATA FOR ENGINE". <Ref. to EN(H4DOTC)-29, Subaru Select Monitor.></p>	Does the measured value exceed the specified value by shaking the ECM harness and connector?	Repair poor contact in ECM connector.	Go to step 6.
<p>6 CHECK HARNESS BETWEEN ECM AND COUPLING CONNECTOR IN REAR WIRING HARNESS.</p> <ol style="list-style-type: none"> 1) Turn ignition switch to OFF. 2) Remove the rear seat cushion. 3) Separate rear wiring harness and fuel tank cord. 4) Turn ignition switch to ON. 5) Measure the voltage between rear wiring harness connector and chassis ground. <p>Connector & terminal (R15) No. 12 (+) — Chassis ground (-):</p>	Is the voltage more than 4.5 V?	Go to step 7.	Repair harness and connector. NOTE: In this case, repair the following: • Open circuit in harness between ECM and rear wiring harness connector • Poor contact in coupling connector

DIAGNOSTIC PROCEDURE WITH DIAGNOSTIC TROUBLE CODE (DTC)

ENGINE (DIAGNOSTICS)

Step	Check	Yes	No
<p>7</p> <p>CHECK HARNESS BETWEEN ECM AND COUPLING CONNECTOR IN REAR WIRING HARNESS. 1) Turn ignition switch to OFF. 2) Disconnect the connector from ECM. 3) Measure the resistance of harness between ECM and rear wiring harness connector.</p> <p>Connector & terminal (B136) No. 35 — (R15) No. 14:</p>	<p>Is the resistance less than 1 Ω?</p>	<p>Go to step 8.</p>	<p>Repair harness and connector.</p> <p>NOTE: In this case, repair the following:</p> <ul style="list-style-type: none"> • Open circuit in harness between ECM and rear wiring harness connector • Poor contact in coupling connector • Poor contact in joint connector
<p>8</p> <p>CHECK HARNESS BETWEEN ECM AND COUPLING CONNECTOR IN REAR WIRING HARNESS. Measure the resistance of harness between rear wiring harness connector and chassis ground.</p> <p>Connector & terminal (R15) No. 14 — Chassis ground:</p>	<p>Is the resistance more than 1 $M\Omega$?</p>	<p>Go to step 9.</p>	<p>Repair short circuit to ground in harness between ECM and rear wiring harness connector.</p>
<p>9</p> <p>CHECK FUEL TANK CORD. 1) Disconnect the connector from fuel tank pressure sensor. 2) Measure the resistance of fuel tank cord.</p> <p>Connector & terminal (R57) No. 12 — (R47) No. 3:</p>	<p>Is the resistance less than 1 Ω?</p>	<p>Go to step 10.</p>	<p>Repair open circuit in fuel tank cord.</p>
<p>10</p> <p>CHECK FUEL TANK CORD. Measure the resistance of fuel tank cord.</p> <p>Connector & terminal (R57) No. 14 — (R47) No. 2:</p>	<p>Is the resistance less than 1 Ω?</p>	<p>Go to step 11.</p>	<p>Repair open circuit in fuel tank cord.</p>
<p>11</p> <p>CHECK FUEL TANK CORD. Measure the resistance of harness between fuel tank pressure sensor connector and engine ground.</p> <p>Connector & terminal (R47) No. 1 — Chassis ground:</p>	<p>Is the resistance more than 1 $M\Omega$?</p>	<p>Go to step 12.</p>	<p>Repair short circuit to ground in fuel tank cord.</p>
<p>12</p> <p>CHECK FOR POOR CONTACT. Check for poor contact in fuel tank pressure sensor connector.</p>	<p>Is there poor contact in fuel tank pressure sensor connector?</p>	<p>Repair poor contact in fuel tank pressure sensor connector.</p>	<p>Replace the fuel tank pressure sensor. <Ref. to EC(H4DOTC)-11, Fuel Tank Pressure Sensor.></p>

DIAGNOSTIC PROCEDURE WITH DIAGNOSTIC TROUBLE CODE (DTC)

ENGINE (DIAGNOSTICS)

BF:DTC P0453 — EVAPORATIVE EMISSION CONTROL SYSTEM PRESSURE SENSOR HIGH INPUT —

DTC DETECTING CONDITION:

- Two consecutive driving cycles with fault
- GENERAL DESCRIPTION <Ref. to GD(H4DOTC)-150, DTC P0453 — EVAPORATIVE EMISSION CONTROL SYSTEM PRESSURE SENSOR HIGH INPUT —, Diagnostic Trouble Code (DTC) Detecting Criteria.>

CAUTION:

After repair or replacement of faulty parts, conduct Clear Memory Mode <Ref. to EN(H4DOTC)-44, OPERATION, Clear Memory Mode.> and Inspection Mode <Ref. to EN(H4DOTC)-36, OPERATION, Inspection Mode.>.

WIRING DIAGRAM:

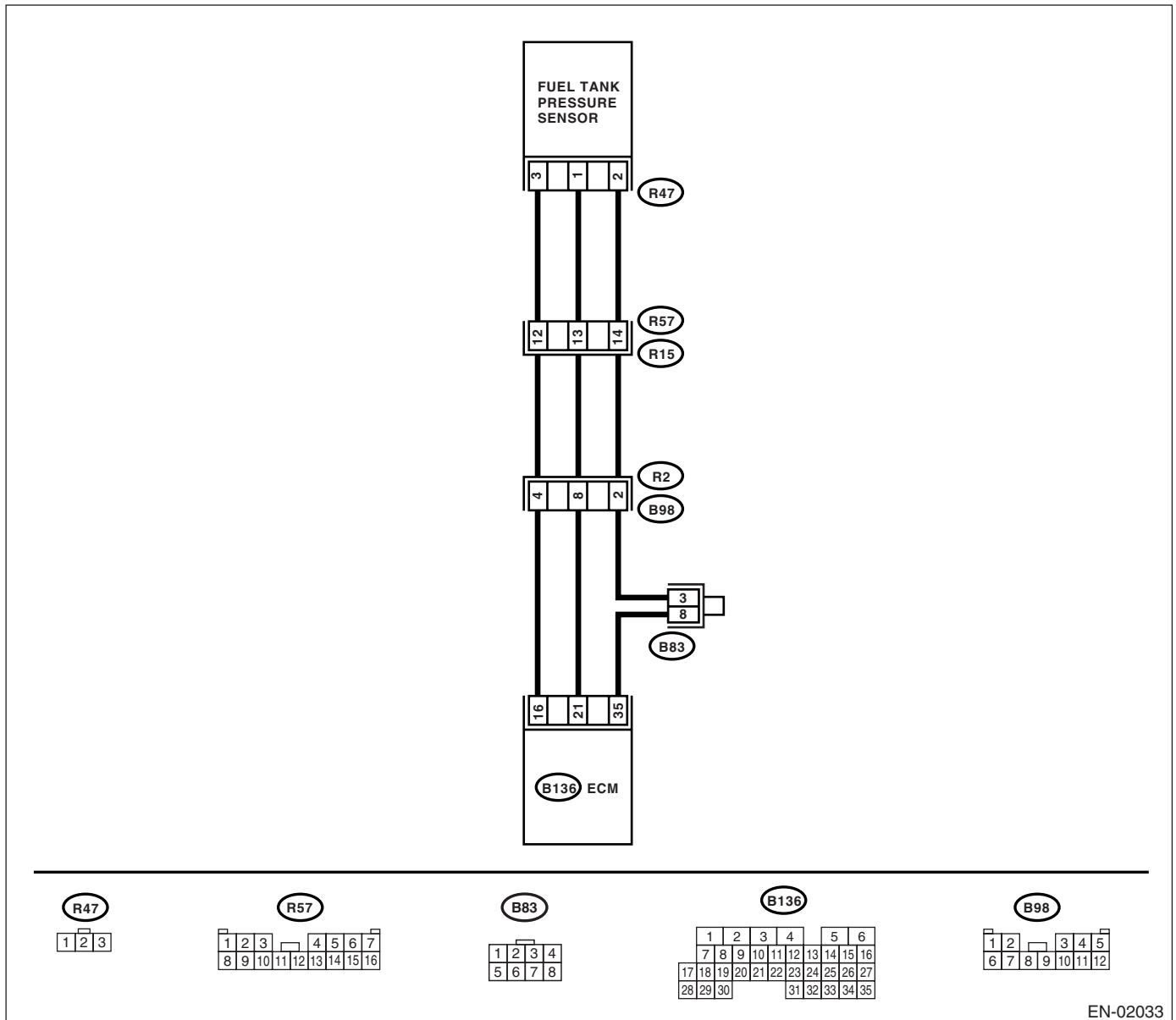

EN-02033

DIAGNOSTIC PROCEDURE WITH DIAGNOSTIC TROUBLE CODE (DTC)

ENGINE (DIAGNOSTICS)

Step	Check	Yes	No
1 CHECK CURRENT DATA. 1) Turn ignition switch to OFF. 2) Remove the fuel filler cap. 3) Install the fuel filler cap. 4) Turn ignition switch to ON. 5) Read the data of fuel tank pressure sensor signal using Subaru Select Monitor or the OBD-II general scan tool. NOTE: • Subaru Select Monitor For detailed operation procedures, refer to "READ CURRENT DATA FOR ENGINE". <Ref. to EN(H4DOTC)-29, Subaru Select Monitor.> • OBD-II general scan tool For detailed operation procedures, refer to the OBD-II General Scan Tool Instruction Manual.	Is the measured value more than 2.8 kPa (21.0 mmHg, 0.827 inHg)	Go to step 11.	Go to step 2.
2 CHECK POWER SUPPLY TO FUEL TANK PRESSURE SENSOR. Measure the voltage between ECM connector and chassis ground. <i>Connector & terminal</i> <i>(B136) No. 16 (+) — Chassis ground (-):</i>	Is the voltage more than 4.5 V?	Go to step 4.	Go to step 3.
3 CHECK POWER SUPPLY TO FUEL TANK PRESSURE SENSOR. Measure the voltage between ECM connector and chassis ground. <i>Connector & terminal</i> <i>(B136) No. 16 (+) — Chassis ground (-):</i>	Does the measured value exceed the specified value by shaking the ECM harness and connector?	Repair poor contact in ECM connector.	Replace the ECM. <Ref. to FU(H4DOTC)-42, Engine Control Module (ECM).>
4 CHECK INPUT SIGNAL FOR ECM. Measure the voltage between ECM and chassis ground. <i>Connector & terminal</i> <i>(B136) No. 21 (+) — Chassis ground (-):</i>	Is the voltage less than 0.2 V?	Go to step 6.	Go to step 5.
5 CHECK INPUT SIGNAL FOR ECM. (USING SUBARU SELECT MONITOR.) Read the data of fuel tank pressure sensor signal using Subaru Select Monitor. NOTE: • Subaru Select Monitor For detailed operation procedures, refer to "READ CURRENT DATA FOR ENGINE". <Ref. to EN(H4DOTC)-29, Subaru Select Monitor.>	Does the measured value exceed -2.8 kPa (-21.0 mmHg, -0.827 inHg) by shaking the ECM harness and connector?	Repair poor contact in ECM connector.	Go to step 6.
6 CHECK HARNESS BETWEEN ECM AND COUPLING CONNECTOR IN REAR WIRING HARNESS. 1) Turn ignition switch to OFF. 2) Remove the rear seat cushion. 3) Separate rear wiring harness and fuel tank cord. 4) Turn ignition switch to ON. 5) Measure the voltage between rear wiring harness connector and chassis ground. <i>Connector & terminal</i> <i>(R15) No. 12 (+) — Chassis ground (-):</i>	Is the voltage more than 4.5 V?	Go to step 7.	Repair harness and connector. NOTE: In this case, repair the following: • Open circuit in harness between ECM and rear wiring harness connector • Poor contact in coupling connector

DIAGNOSTIC PROCEDURE WITH DIAGNOSTIC TROUBLE CODE (DTC)

ENGINE (DIAGNOSTICS)

Step	Check	Yes	No
7 CHECK HARNESS BETWEEN ECM AND COUPLING CONNECTOR IN REAR WIRING HARNESS. 1) Turn ignition switch to OFF. 2) Disconnect the connector from ECM. 3) Measure the resistance of harness between ECM and rear wiring harness connector. Connector & terminal (B136) No. 21 — (R15) No. 13: (B136) No. 35 — (R15) No. 14:	Is the resistance less than 1 Ω ?	Go to step 8 .	Repair harness and connector. NOTE: In this case, repair the following: <ul style="list-style-type: none"> • Open circuit in harness between ECM and rear wiring harness connector • Poor contact in coupling connector
8 CHECK FUEL TANK CORD. 1) Disconnect the connector from fuel tank pressure sensor. 2) Measure the resistance of fuel tank cord. Connector & terminal (R57) No. 13 — (R47) No. 1:	Is the resistance less than 1 Ω ?	Go to step 9 .	Repair open circuit in fuel tank cord.
9 CHECK FUEL TANK CORD. Measure the resistance of fuel tank cord. Connector & terminal (R57) No. 14 — (R47) No. 2:	Is the resistance less than 1 Ω ?	Go to step 10 .	Repair open circuit in fuel tank cord.
10 CHECK FOR POOR CONTACT. Check for poor contact in fuel tank pressure sensor connector.	Is there poor contact in fuel tank pressure sensor connector?	Repair poor contact in fuel tank pressure sensor connector.	Replace the fuel tank pressure sensor. <Ref. to EC(H4DOTC)-11, Fuel Tank Pressure Sensor.>
11 CHECK HARNESS BETWEEN ECM AND FUEL TANK PRESSURE SENSOR CONNECTOR. 1) Turn ignition switch to OFF. 2) Disconnect the connector from fuel tank pressure sensor. 3) Turn ignition switch to ON. 4) Read the data of fuel tank pressure sensor signal using Subaru Select Monitor or the OBD-II general scan tool. NOTE: <ul style="list-style-type: none"> • Subaru Select Monitor For detailed operation procedures, refer to "READ CURRENT DATA FOR ENGINE". <Ref. to EN(H4DOTC)-29, Subaru Select Monitor.> <ul style="list-style-type: none"> • OBD-II general scan tool For detailed operation procedures, refer to the OBD-II General Scan Tool Instruction Manual.	Is the measured value more than 2.8 kPa (21.0 mmHg, 0.827 inHg)?	Repair short circuit to battery in harness between ECM and fuel tank pressure sensor connector.	Replace the fuel tank pressure sensor. <Ref. to EC(H4DOTC)-11, Fuel Tank Pressure Sensor.>

BG:DTC P0456 — EVAPORATIVE EMISSION CONTROL SYSTEM LEAK DETECTED (VERY SMALL LEAK) —

DTC DETECTING CONDITION:

- Two consecutive driving cycles with fault
- GENERAL DESCRIPTION <Ref. to GD(H4DOTC)-152, DTC P0456 — EVAPORATIVE EMISSION CONTROL SYSTEM LEAK DETECTED (VERY SMALL LEAK) —, Diagnostic Trouble Code (DTC) Detecting Criteria.>

TROUBLE SYMPTOM:

- Fuel odor
- There is a hole of more than 0.5 mm (0.020 in) dia. in evaporation system or fuel tank.

CAUTION:

After repair or replacement of faulty parts, conduct Clear Memory Mode <Ref. to EN(H4DOTC)-44, OPERATION, Clear Memory Mode.> and Inspection Mode <Ref. to EN(H4DOTC)-36, OPERATION, Inspection Mode.>.

DIAGNOSTIC PROCEDURE WITH DIAGNOSTIC TROUBLE CODE (DTC) ENGINE (DIAGNOSTICS)

WIRING DIAGRAM:

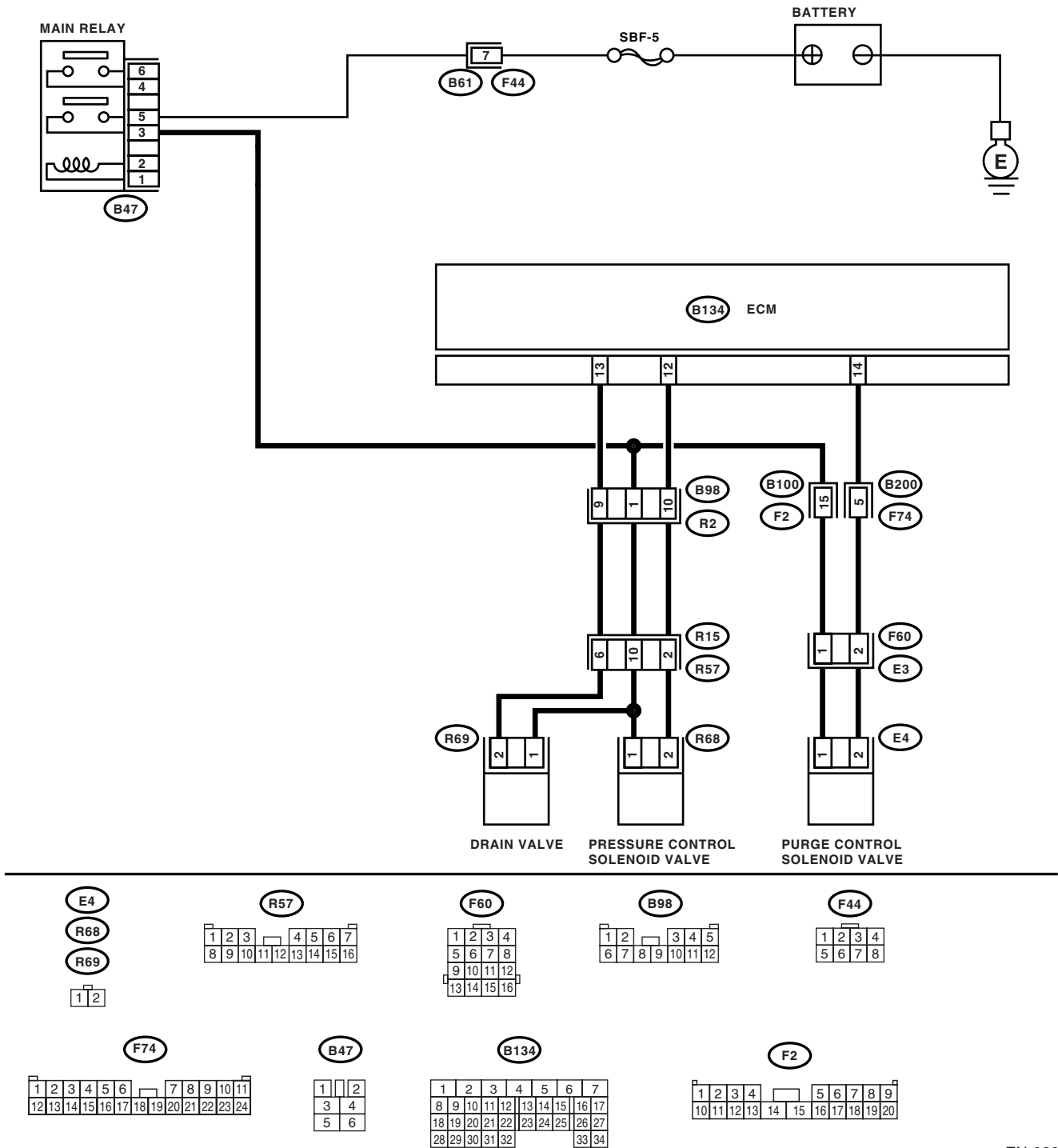

EN-02031

DIAGNOSTIC PROCEDURE WITH DIAGNOSTIC TROUBLE CODE (DTC)

ENGINE (DIAGNOSTICS)

Step	Check	Yes	No	
1	CHECK FOR OTHER DTC ON DISPLAY.	Is any other DTC displayed?	Inspect the relevant DTC using "List of Diagnostic Trouble Code (DTC)". <Ref. to EN(H4DOTC)-68, List of Diagnostic Trouble Code (DTC).>	Go to step 2.
2	CHECK FUEL FILLER CAP. 1) Turn ignition switch to OFF. 2) Check the fuel filler cap. NOTE: The DTC is stored in memory if fuel filler cap is or was loose or if the cap chain was caught while tightening.	Is the fuel filler cap tightened securely?	Go to step 3.	Tighten fuel filler cap securely.
3	CHECK FUEL FILLER CAP.	Is the fuel filler cap SUBARU genuine?	Go to step 4.	Replace with a SUBARU genuine fuel filler cap.
4	CHECK FUEL FILLER PIPE PACKING.	Is there any damage to the seal between fuel filler cap and fuel filler pipe?	Repair or replace the fuel filler cap and fuel filler pipe. <Ref. to FU(H4DOTC)-50, Fuel Filler Pipe.>	Go to step 5.
5	CHECK DRAIN VALVE. 1) Connect the test mode connector. 2) Turn ignition switch to ON. 3) Operate the drain valve. NOTE: Drain valve operation can also be executed using Subaru Select Monitor. For the procedure, refer to "Compulsory Valve Operation Check Mode". <Ref. to EN(H4DOTC)-45, Compulsory Valve Operation Check Mode.>	Does the drain valve operate?	Go to step 6.	Replace the drain valve. <Ref. to EC(H4DOTC)-19, Drain Valve.>
6	CHECK PURGE CONTROL SOLENOID VALVE. Operate the purge control solenoid valve. NOTE: Purge control solenoid valve operation can also be executed using Subaru Select Monitor. For the procedure, refer to "Compulsory Valve Operation Check Mode". <Ref. to EN(H4DOTC)-45, Compulsory Valve Operation Check Mode.>	Does the purge control solenoid valve operate?	Go to step 7.	Replace the purge control solenoid valve. <Ref. to EC(H4DOTC)-7, Purge Control Solenoid Valve.>
7	CHECK PRESSURE CONTROL SOLENOID VALVE. Operate the pressure control solenoid valve. NOTE: Pressure control solenoid valve operation can also be executed using Subaru Select Monitor. For the procedure, refer to "Compulsory Valve Operation Check Mode". <Ref. to EN(H4DOTC)-45, Compulsory Valve Operation Check Mode.>	Does the pressure control solenoid valve operate?	Go to step 8.	Replace the pressure control solenoid valve. <Ref. to EC(H4DOTC)-7, Purge Control Solenoid Valve.>

DIAGNOSTIC PROCEDURE WITH DIAGNOSTIC TROUBLE CODE (DTC)

ENGINE (DIAGNOSTICS)

Step	Check	Yes	No	
8	CHECK EVAPORATIVE EMISSION CONTROL SYSTEM LINE. Turn ignition switch to OFF.	Is there a hole of more than 0.5 mm (0.020 in) dia. on evaporation line?	Repair or replace the evaporation line. <Ref. to FU(H4DOTC)-63, Fuel Delivery, Return and Evaporation Lines.>	Go to step 9 .
9	CHECK CANISTER.	Is the canister damaged or is there a hole of more than 0.5 mm (0.020 in) dia. in it?	Repair or replace the canister. <Ref. to EC(H4DOTC)-6, Canister.>	Go to step 10 .
10	CHECK FUEL TANK. Remove the fuel tank. <Ref. to FU(H4DOTC)-47, Fuel Tank.>	Is the fuel tank damaged or is there a hole of more than 0.5 mm (0.020 in) dia. in it?	Repair or replace the fuel tank. <Ref. to FU(H4DOTC)-47, Fuel Tank.>	Go to step 11 .
11	CHECK ANY OTHER MECHANICAL TROUBLE IN EVAPORATIVE EMISSION CONTROL SYSTEM.	Are there holes of more than 0.5 mm (0.020 in) dia., cracks, clogging, or disconnections, bend, misconnection of hoses or pipes in evaporative emission control system?	Repair or replace the hoses or pipes.	Contact with SOA Service Center. NOTE: Inspection by DTM is required, because probable cause is deterioration of multiple parts.

BH:DTC P0457 — EVAPORATIVE EMISSION CONTROL SYSTEM LEAK DETECTED (FUEL CAP LOOSE/OFF) —

DTC DETECTING CONDITION:

- Two consecutive driving cycles with fault
- GENERAL DESCRIPTION <Ref. to GD(H4DOTC)-152, DTC P0457 — EVAPORATIVE EMISSION CONTROL SYSTEM LEAK DETECTED (FUEL CAP LOOSE/OFF) —, Diagnostic Trouble Code (DTC) Detecting Criteria.>

TROUBLE SYMPTOM:

- Fuel odor
- Fuel filler cap is loose or not installed.

CAUTION:

After repair or replacement of faulty parts, conduct Clear Memory Mode <Ref. to EN(H4DOTC)-44, OPERATION, Clear Memory Mode.> and Inspection Mode <Ref. to EN(H4DOTC)-36, OPERATION, Inspection Mode.>.

DIAGNOSTIC PROCEDURE WITH DIAGNOSTIC TROUBLE CODE (DTC) ENGINE (DIAGNOSTICS)

WIRING DIAGRAM:

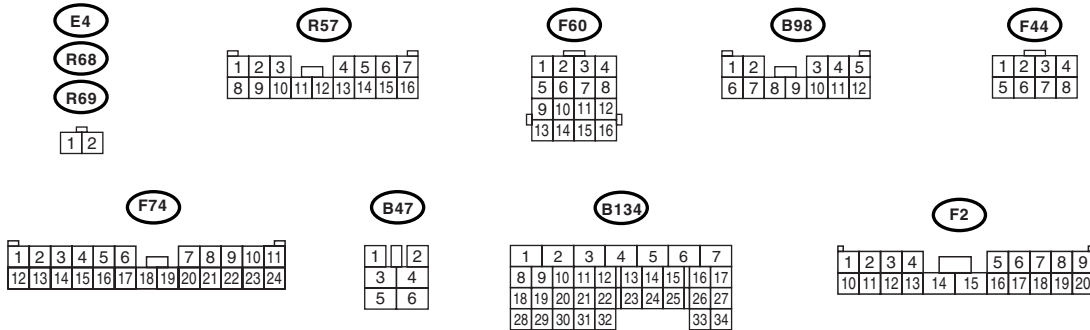
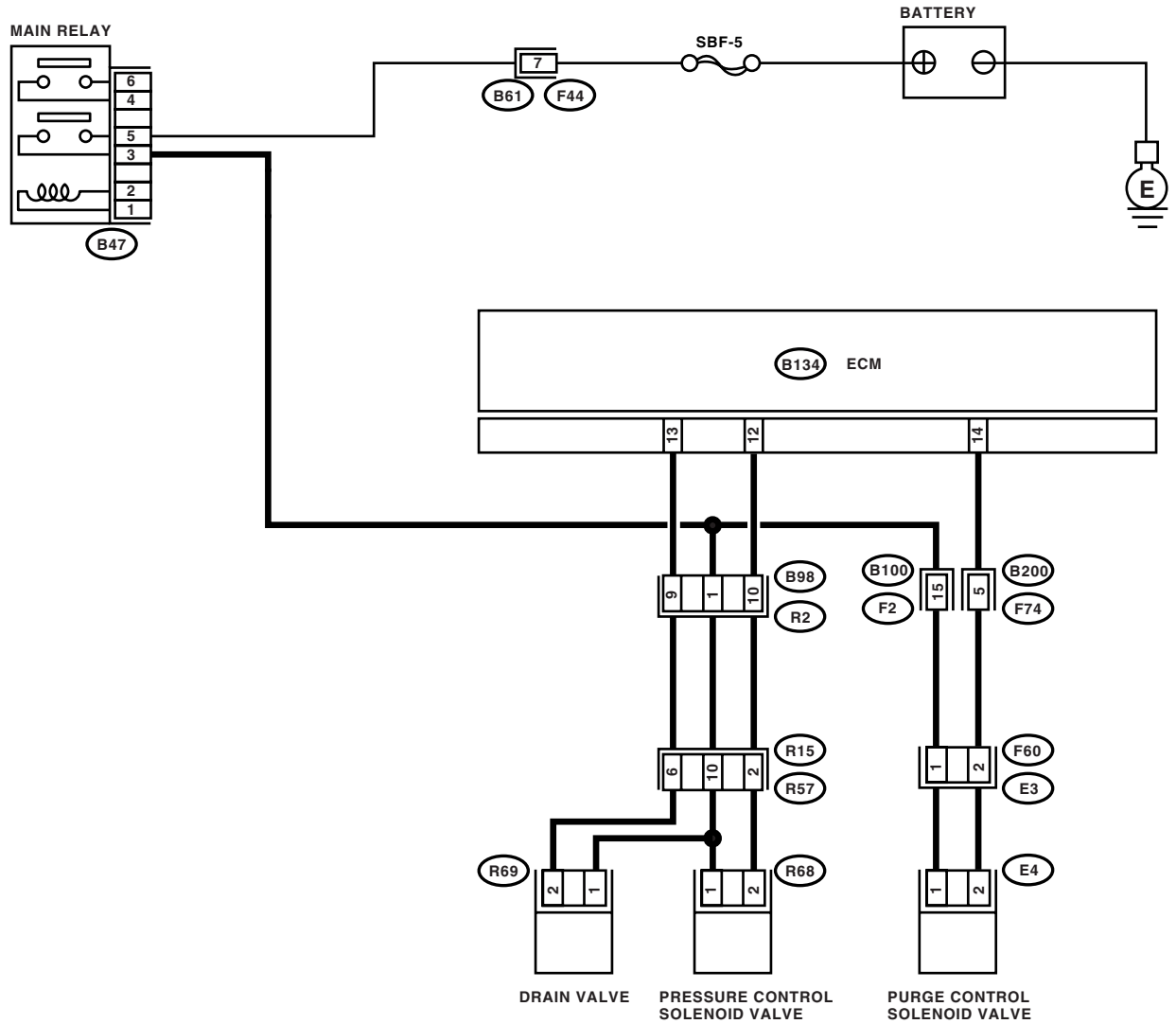

EN-02031

DIAGNOSTIC PROCEDURE WITH DIAGNOSTIC TROUBLE CODE (DTC)

ENGINE (DIAGNOSTICS)

Step	Check	Yes	No
1	CHECK FOR OTHER DTC ON DISPLAY.	Is any other DTC displayed?	Inspect the relevant DTC using "List of Diagnostic Trouble Code (DTC)". <Ref. to EN(H4DOTC)-68, List of Diagnostic Trouble Code (DTC).>
2	CHECK FUEL FILLER CAP. 1) Turn ignition switch to OFF. 2) Check the fuel filler cap. NOTE: The DTC is stored in memory if fuel filler cap is or was loose or if the cap chain was caught while tightening.	Is the fuel filler cap tightened securely?	Go to step 3. Tighten fuel filler cap securely.
3	CHECK FUEL FILLER CAP.	Is the fuel filler cap SUBARU genuine?	Go to step 4. Replace with a SUBARU genuine fuel filler cap.
4	CHECK FUEL FILLER PIPE PACKING.	Is there any damage to the seal between fuel filler cap and fuel filler pipe?	Repair or replace the fuel filler cap and fuel filler pipe. <Ref. to FU(H4DOTC)-50, Fuel Filler Pipe.> Go to step 5.
5	CHECK DRAIN VALVE. 1) Connect the test mode connector. 2) Turn ignition switch to ON. 3) Operate the drain valve. NOTE: Drain valve operation can also be executed using Subaru Select Monitor. For the procedure, refer to "Compulsory Valve Operation Check Mode". <Ref. to EN(H4DOTC)-45, Compulsory Valve Operation Check Mode.>	Does the drain valve operate?	Go to step 6. Replace the drain valve. <Ref. to EC(H4DOTC)-7, Purge Control Solenoid Valve.>
6	CHECK PURGE CONTROL SOLENOID VALVE. Operate the purge control solenoid valve. NOTE: Purge control solenoid valve operation can also be executed using Subaru Select Monitor. For the procedure, refer to "Compulsory Valve Operation Check Mode". <Ref. to EN(H4DOTC)-68, List of Diagnostic Trouble Code (DTC).>	Does the purge control solenoid valve operate?	Go to step 7. Replace the purge control solenoid valve. <Ref. to EC(H4DOTC)-7, Purge Control Solenoid Valve.>
7	CHECK PRESSURE CONTROL SOLENOID VALVE. Operate the pressure control solenoid valve. NOTE: Pressure control solenoid valve operation can also be executed using Subaru Select Monitor. For the procedure, refer to "Compulsory Valve Operation Check Mode". <Ref. to EN(H4DOTC)-45, Compulsory Valve Operation Check Mode.>	Does the pressure control solenoid valve operate?	Go to step 8. Replace the pressure control solenoid valve. <Ref. to EC(H4DOTC)-7, Purge Control Solenoid Valve.>
8	CHECK CANISTER.	Is the canister damaged?	Repair or replace the canister. <Ref. to EC(H4DOTC)-6, Canister.> Go to step 9.

DIAGNOSTIC PROCEDURE WITH DIAGNOSTIC TROUBLE CODE (DTC)

ENGINE (DIAGNOSTICS)

Step	Check	Yes	No
9 CHECK FUEL TANK. Remove the fuel tank. <Ref. to FU(H4DOTC)-47, Fuel Tank.>	Is the fuel tank damaged?	Repair or replace the fuel tank. <Ref. to FU(H4DOTC)-47, Fuel Tank.>	Go to step 10 .
10 CHECK ANY OTHER MECHANICAL TROUBLE IN EVAPORATIVE EMISSION CONTROL SYSTEM.	Are there holes of more than 0.5 mm (0.020 in) dia., cracks, clogging, or disconnections, misconnection of hoses or pipes in evaporative emission control system?	Repair or replace the hoses or pipes.	Contact with SOA Service Center. NOTE: Inspection by DTM is required, because probable cause is deterioration of multiple parts.

DIAGNOSTIC PROCEDURE WITH DIAGNOSTIC TROUBLE CODE (DTC)

ENGINE (DIAGNOSTICS)

BI: DTC P0458 — EVAPORATIVE EMISSION CONTROL SYSTEM PURGE CONTROL VALVE CIRCUIT LOW —

DTC DETECTING CONDITION:

- Two consecutive driving cycles with fault
- GENERAL DESCRIPTION <Ref. to GD(H4DOTC)-153, DTC P0458 — EVAPORATIVE EMISSION CONTROL SYSTEM PURGE CONTROL VALVE CIRCUIT LOW —, Diagnostic Trouble Code (DTC) Detecting Criteria.>

TROUBLE SYMPTOM:

Erroneous idling

CAUTION:

After repair or replacement of faulty parts, conduct Clear Memory Mode <Ref. to EN(H4DOTC)-44, OPERATION, Clear Memory Mode.> and Inspection Mode <Ref. to EN(H4DOTC)-36, OPERATION, Inspection Mode.>.

WIRING DIAGRAM:

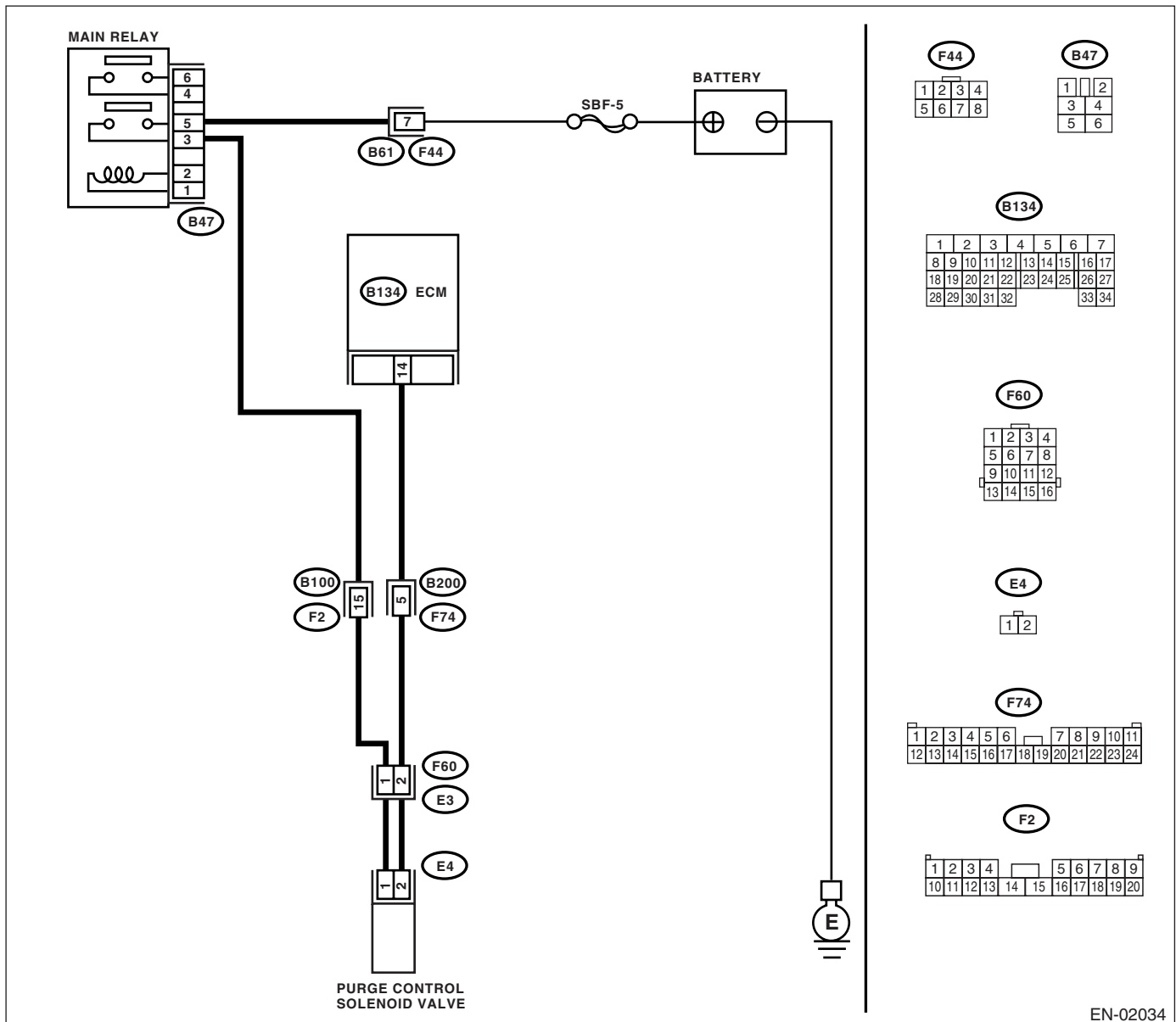

EN-02034

DIAGNOSTIC PROCEDURE WITH DIAGNOSTIC TROUBLE CODE (DTC)

ENGINE (DIAGNOSTICS)

Step	Check	Yes	No
1 CHECK OUTPUT SIGNAL FROM ECM. 1) Turn the ignition switch to ON. 2) Measure the voltage between ECM and chassis ground. <i>Connector & terminal</i> <i>(B134) No. 14 (+) — Chassis ground (-):</i>	Is the voltage more than 10 V?	Even if malfunction indicator light lights up, the circuit has returned to a normal condition at this time.	Go to step 2.
2 CHECK HARNESS BETWEEN PURGE CONTROL SOLENOID VALVE AND ECM CONNECTOR. 1) Turn the ignition switch to OFF. 2) Disconnect the connectors from purge control solenoid valve and ECM. 3) Measure the resistance of harness between purge control solenoid valve connector and engine ground. <i>Connector & terminal</i> <i>(E4) No. 2 — Engine ground:</i>	Is the resistance more than 1 M Ω ?	Go to step 3.	Repair the ground short circuit in harness between ECM and purge control solenoid valve connector.
3 CHECK HARNESS BETWEEN PURGE CONTROL SOLENOID VALVE AND ECM CONNECTOR. Measure the resistance of harness between ECM and purge control solenoid valve of harness connector. <i>Connector & terminal</i> <i>(B134) No. 14 — (E4) No. 2:</i>	Is the resistance less than 1 Ω ?	Go to step 4.	Repair the open circuit in harness between ECM and purge control solenoid valve connector. NOTE: In this case, repair the following: <ul style="list-style-type: none"> • Open circuit in harness between ECM and purge control solenoid valve connector • Poor contact in coupling connector
4 CHECK PURGE CONTROL SOLENOID VALVE. 1) Remove the purge control solenoid valve. 2) Measure the resistance between purge control solenoid valve terminals. <i>Terminals</i> <i>No. 1 — No. 2:</i>	Is the resistance 10 — 100 Ω ?	Go to step 5.	Replace the purge control solenoid valve. <Ref. to EC(H4DOTC)-7, Purge Control Solenoid Valve.>
5 CHECK POWER SUPPLY TO PURGE CONTROL SOLENOID VALVE. 1) Turn the ignition switch to ON. 2) Measure the voltage between purge control solenoid valve and engine ground. <i>Connector & terminal</i> <i>(E4) No. 1 (+) — Engine ground (-):</i>	Is the voltage more than 10 V?	Go to step 6.	Repair the open circuit in harness between main relay and purge control solenoid valve connector.
6 CHECK POOR CONTACT. Check poor contact in purge control solenoid valve connector.	Is there poor contact in purge control solenoid valve connector?	Repair the poor contact in purge control solenoid valve connector.	Contact your SOA Service Center. NOTE: Inspection by DTM is required, because probable cause is deterioration of multiple parts.

DIAGNOSTIC PROCEDURE WITH DIAGNOSTIC TROUBLE CODE (DTC)

ENGINE (DIAGNOSTICS)

BJ:DTC P0459 — EVAPORATIVE EMISSION CONTROL SYSTEM PURGE CONTROL VALVE CIRCUIT HIGH —

DTC DETECTING CONDITION:

- Two consecutive driving cycles with fault
- GENERAL DESCRIPTION <Ref. to GD(H4DOTC)-155, DTC P0459 — EVAPORATIVE EMISSION CONTROL SYSTEM PURGE CONTROL VALVE CIRCUIT HIGH —, Diagnostic Trouble Code (DTC) Detecting Criteria.>

TROUBLE SYMPTOM:

Erroneous idling

CAUTION:

After repair or replacement of faulty parts, conduct Clear Memory Mode <Ref. to EN(H4DOTC)-44, OPERATION, Clear Memory Mode.> and Inspection Mode <Ref. to EN(H4DOTC)-36, OPERATION, Inspection Mode.>.

WIRING DIAGRAM:

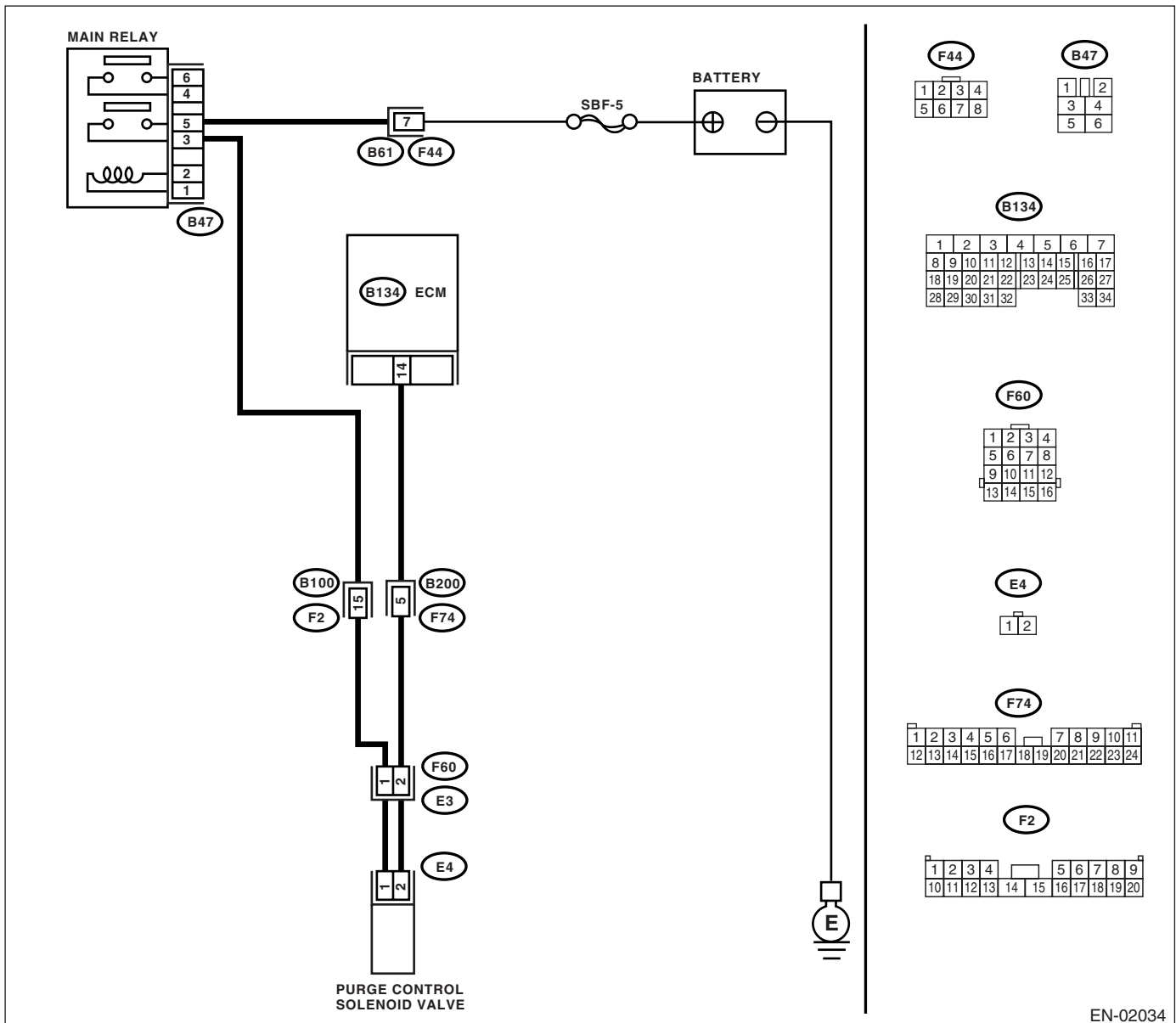

EN-02034

DIAGNOSTIC PROCEDURE WITH DIAGNOSTIC TROUBLE CODE (DTC)

ENGINE (DIAGNOSTICS)

Step	Check	Yes	No
1 CHECK OUTPUT SIGNAL FROM ECM. 1) Turn the ignition switch to OFF. 2) Connect the test mode connector at the lower portion of instrument panel (on the driver's side). 3) Turn the ignition switch to ON. 4) While operating the purge control solenoid valve, measure the voltage between ECM and chassis ground. NOTE: Purge control solenoid valve operation can be executed using the Subaru Select Monitor. For procedure, refer to "Compulsory Valve Operation Check Mode". <Ref. to EN(H4DOTC)-45, Compulsory Valve Operation Check Mode.> Connector & terminal (B134) No. 14 (+) — Chassis ground (-):	Is the voltage 0 — 13 V?	Go to step 2.	Even if malfunction indicator light lights up, the circuit has returned to a normal condition at this time. In this case, repair the poor contact in ECM connector.
2 CHECK OUTPUT SIGNAL FROM ECM. 1) Turn the ignition switch to ON. 2) Measure the voltage between ECM and chassis ground. Connector & terminal (B134) No. 14 (+) — Chassis ground (-):	Is the voltage more than 10 V?	Go to step 4.	Go to step 3.
3 CHECK POOR CONTACT. Check the poor contact in ECM connector.	Is there poor contact in ECM connector?	Repair the poor contact in ECM connector.	Replace the ECM. <Ref. to FU(H4DOTC)-42, Engine Control Module (ECM).>
4 CHECK HARNESS BETWEEN PURGE CONTROL SOLENOID VALVE AND ECM CONNECTOR. 1) Turn the ignition switch to OFF. 2) Disconnect the connector from purge control solenoid valve. 3) Turn the ignition switch to ON. 4) Measure the voltage between ECM and chassis ground. Connector & terminal (B134) No. 14 (+) — Chassis ground (-):	Is the voltage more than 10 V?	Repair the battery short circuit in harness between ECM and purge control solenoid valve connector. After repair, replace the ECM. <Ref. to FU(H4DOTC)-42, Engine Control Module (ECM).>	Go to step 5.
5 CHECK PURGE CONTROL SOLENOID VALVE. 1) Turn the ignition switch to OFF. 2) Measure the resistance between purge control solenoid valve terminals. Terminals No. 1 — No. 2:	Is the resistance less than 1 Ω ?	Replace the purge control solenoid valve <Ref. to EC(H4DOTC)-7, Purge Control Solenoid Valve.> and ECM <Ref. to FU(H4DOTC)-42, Engine Control Module (ECM).>	Go to step 6.
6 CHECK POOR CONTACT. Check poor contact in ECM connector.	Is there poor contact in ECM connector?	Repair the poor contact in ECM connector.	Replace the ECM. <Ref. to FU(H4DOTC)-42, Engine Control Module (ECM).>

**BK:DTC P0461 — FUEL LEVEL SENSOR CIRCUIT RANGE/PERFORMANCE —
DTC DETECTING CONDITION:**

- Two consecutive driving cycles with fault
- GENERAL DESCRIPTION <Ref. to GD(H4DOTC)-157, DTC P0461 — FUEL LEVEL SENSOR CIRCUIT RANGE/PERFORMANCE —, Diagnostic Trouble Code (DTC) Detecting Criteria.>

CAUTION:

After repair or replacement of faulty parts, conduct Clear Memory Mode <Ref. to EN(H4DOTC)-44, OPERATION, Clear Memory Mode.> and Inspection Mode <Ref. to EN(H4DOTC)-36, OPERATION, Inspection Mode.>.

DIAGNOSTIC PROCEDURE WITH DIAGNOSTIC TROUBLE CODE (DTC)

ENGINE (DIAGNOSTICS)

WIRING DIAGRAM:

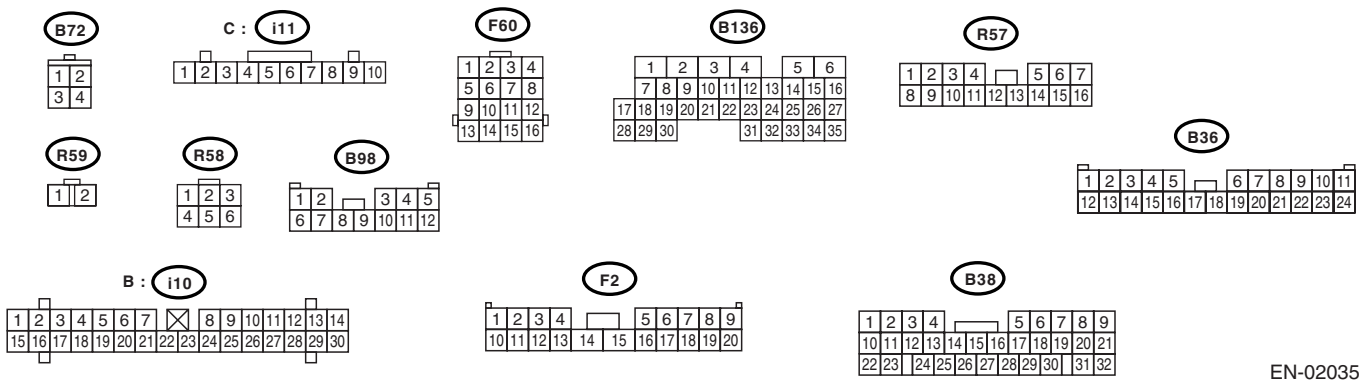
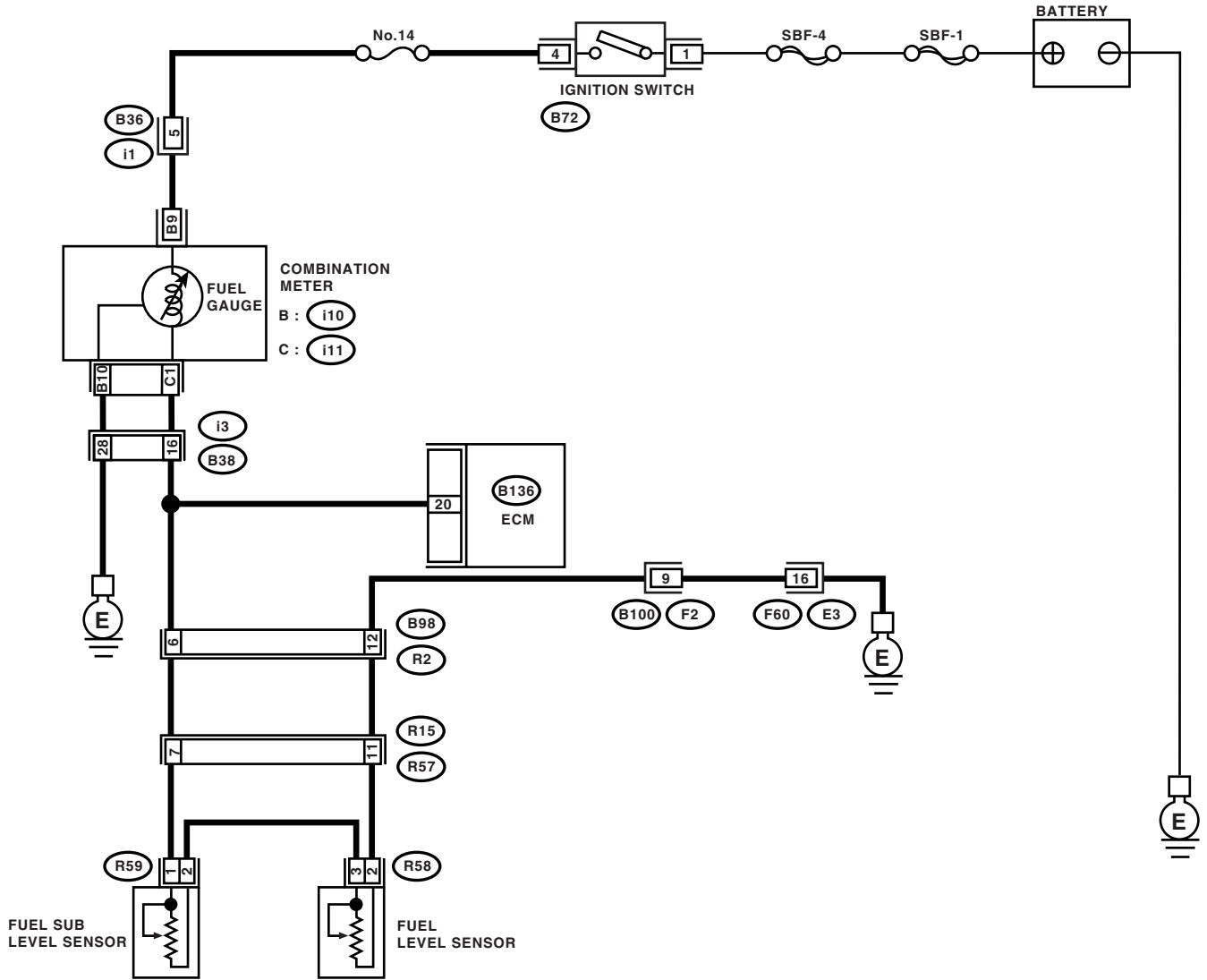

EN-02035

DIAGNOSTIC PROCEDURE WITH DIAGNOSTIC TROUBLE CODE (DTC)

ENGINE (DIAGNOSTICS)

Step	Check	Yes	No
1 CHECK ANY OTHER DTC ON DISPLAY.	Is any other DTC displayed?	Inspect the relevant DTC using "List of Diagnostic Trouble Code (DTC)". <Ref. to EN(H4DOTC)-68, List of Diagnostic Trouble Code (DTC).> NOTE: In this case, it is not necessary to inspect DTC P0461.	Replace the fuel level sensor. <Ref. to FU(H4DOTC)-57, Fuel Level Sensor.> and fuel sub level sensor<Ref. to FU(H4DOTC)-58, Fuel Sub Level Sensor.>

DIAGNOSTIC PROCEDURE WITH DIAGNOSTIC TROUBLE CODE (DTC)

ENGINE (DIAGNOSTICS)

BL:DTC P0462 — FUEL LEVEL SENSOR CIRCUIT LOW INPUT —

DTC DETECTING CONDITION:

- Two consecutive driving cycles with fault
- GENERAL DESCRIPTION <Ref. to GD(H4DOTC)-159, DTC P0462 — FUEL LEVEL SENSOR CIRCUIT LOW INPUT —, Diagnostic Trouble Code (DTC) Detecting Criteria.>

CAUTION:

After repair or replacement of faulty parts, conduct Clear Memory Mode <Ref. to EN(H4DOTC)-44, OPERATION, Clear Memory Mode.> and Inspection Mode <Ref. to EN(H4DOTC)-36, OPERATION, Inspection Mode.>.

DIAGNOSTIC PROCEDURE WITH DIAGNOSTIC TROUBLE CODE (DTC)

ENGINE (DIAGNOSTICS)

WIRING DIAGRAM:

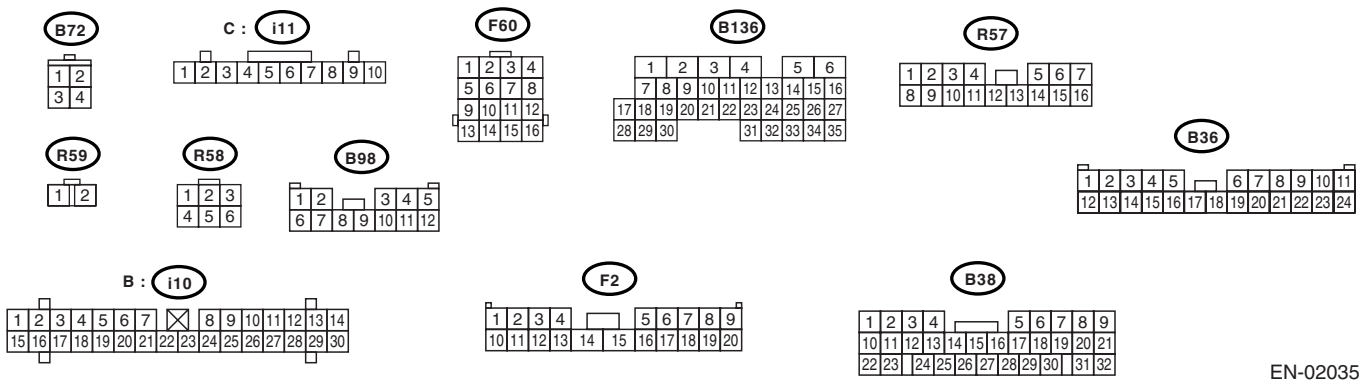
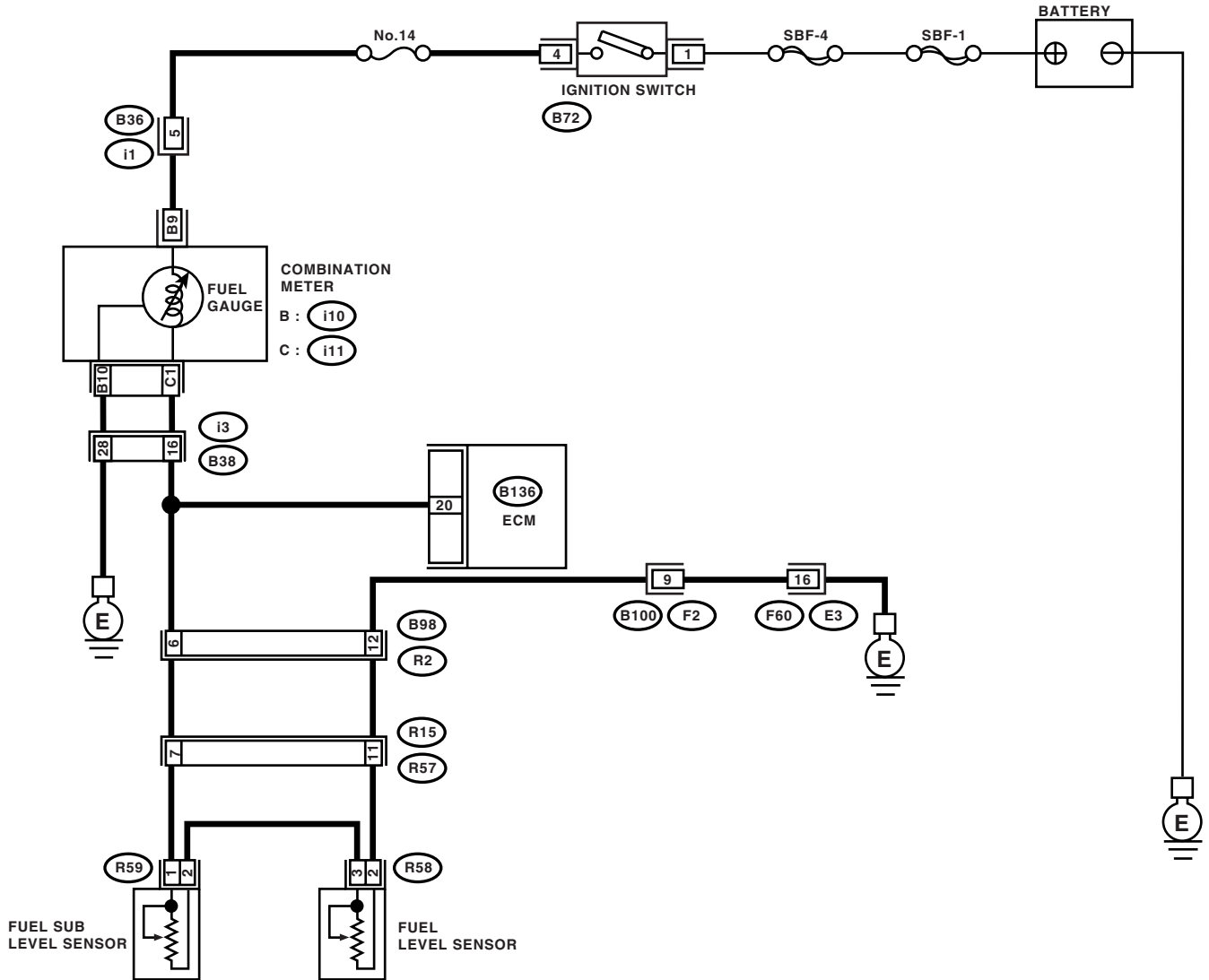

EN-02035

DIAGNOSTIC PROCEDURE WITH DIAGNOSTIC TROUBLE CODE (DTC)

ENGINE (DIAGNOSTICS)

Step	Check	Yes	No
1	CHECK SPEEDOMETER AND TACHOMETER OPERATION IN COMBINATION METER.	Go to step 2.	Repair or replace the combination meter. <Ref. to IDI-3, Combination Meter System.>
2	CHECK INPUT SIGNAL FOR ECM. 1) Turn the ignition switch to ON. (engine OFF) 2) Measure the voltage between ECM connector and chassis ground. Connector & terminal (B136) No. 20 (+) — Chassis ground (-):	Go to step 4.	Go to step 3.
3	CHECK INPUT SIGNAL FOR ECM. (USING SUBARU SELECT MONITOR) Read the data of fuel level sensor signal using Subaru Select Monitor. NOTE: • Subaru Select Monitor For detailed operation procedure, refer to the "READ CURRENT DATA FOR ENGINE". <Ref. to EN(H4DOTC)-29, Subaru Select Monitor.>	Repair the poor contact in ECM connector.	Even if malfunction indicator light lights up, the circuit has returned to a normal condition at this time. A temporary poor contact of the connector may be the cause. NOTE: In this case, repair the following: • Poor contact in combination meter connector • Poor contact in ECM connector • Poor contact in coupling connectors
4	CHECK INPUT VOLTAGE OF ECM. 1) Turn the ignition switch to OFF. 2) Separate the fuel tank cord connector (R57) and rear wiring harness connector (R15). 3) Turn the ignition switch to ON. 4) Measure the voltage of harness between ECM connector and chassis ground. Connector & terminal (B136) No. 20 (+) — Chassis ground (-):	Go to step 5.	Go to step 6.
5	CHECK HARNESS BETWEEN ECM AND COMBINATION METER. 1) Turn the ignition switch to OFF. 2) Disconnect the connector from connector (i11), (i12) and ECM connector. 3) Measure the resistance between ECM and chassis ground. Connector & terminal (B136) No. 20 — Chassis ground:	Go to step 7.	Repair the ground short circuit in harness between ECM and combination meter connector.

DIAGNOSTIC PROCEDURE WITH DIAGNOSTIC TROUBLE CODE (DTC)

ENGINE (DIAGNOSTICS)

Step	Check	Yes	No
6 CHECK HARNESS BETWEEN ECM AND COMBINATION METER. Measure the resistance between ECM and combination meter connector. <i>Connector & terminal</i> <i>(B136) No. 20 — (i11) No. 1:</i>	Is the resistance less than 10 Ω ?	Repair or replace the combination meter. <Ref. to IDI-3, Combination Meter System.>	Repair the open circuit between ECM and combination meter connector. NOTE: In this case, repair the following: Poor contact in coupling connector
7 CHECK FUEL TANK CORD. 1) Turn the ignition switch to OFF. 2) Disconnect the connector from fuel sub level sensor. 3) Measure the resistance between fuel sub level sensor and chassis ground. <i>Connector & terminal</i> <i>(R59) No. 1 — Chassis ground:</i>	Is the resistance more than 1 M Ω ?	Go to step 8.	Repair the ground short circuit in fuel tank cord.
8 CHECK FUEL TANK CORD. 1) Disconnect the connector from fuel pump assembly. 2) Measure the resistance between fuel pump assembly and chassis ground. <i>Connector & terminal</i> <i>(R59) No. 2 — Chassis ground:</i>	Is the resistance more than 1 M Ω ?	Go to step 9.	Repair the ground short circuit in fuel tank cord.
9 CHECK FUEL LEVEL SENSOR. 1) Remove the fuel pump assembly. <Ref. to FU(H4DOTC)-55, Fuel Pump.> 2) Measure the resistance between fuel level sensor and terminals with its float set to the full position. <i>Terminals</i> <i>No. 2 — No. 3:</i>	Is the resistance 0.5 — 2.5 Ω ?	Go to step 10.	Replace the fuel level sensor.
10 CHECK FUEL SUB LEVEL SENSOR. 1) Remove the fuel sub level sensor. <Ref. to FU(H4DOTC)-58, Fuel Sub Level Sensor.> 2) Measure the resistance between fuel sub level sensor and terminals with its float set to the full position. <i>Terminals</i> <i>No. 1 — No. 2:</i>	Is the resistance 0.5 — 2.5 Ω ?	Repair the poor contact in harness between ECM and combination meter connector.	Replace the fuel sub level sensor.

DIAGNOSTIC PROCEDURE WITH DIAGNOSTIC TROUBLE CODE (DTC)

ENGINE (DIAGNOSTICS)

BM:DTC P0463 — FUEL LEVEL SENSOR CIRCUIT HIGH INPUT —

DTC DETECTING CONDITION:

- Two consecutive driving cycles with fault
- GENERAL DESCRIPTION <Ref. to GD(H4DOTC)-161, DTC P0463 — FUEL LEVEL SENSOR CIRCUIT HIGH INPUT —, Diagnostic Trouble Code (DTC) Detecting Criteria.>

CAUTION:

After repair or replacement of faulty parts, conduct Clear Memory Mode <Ref. to EN(H4DOTC)-44, OPERATION, Clear Memory Mode.> and Inspection Mode <Ref. to EN(H4DOTC)-36, OPERATION, Inspection Mode.>.

DIAGNOSTIC PROCEDURE WITH DIAGNOSTIC TROUBLE CODE (DTC)

ENGINE (DIAGNOSTICS)

WIRING DIAGRAM:

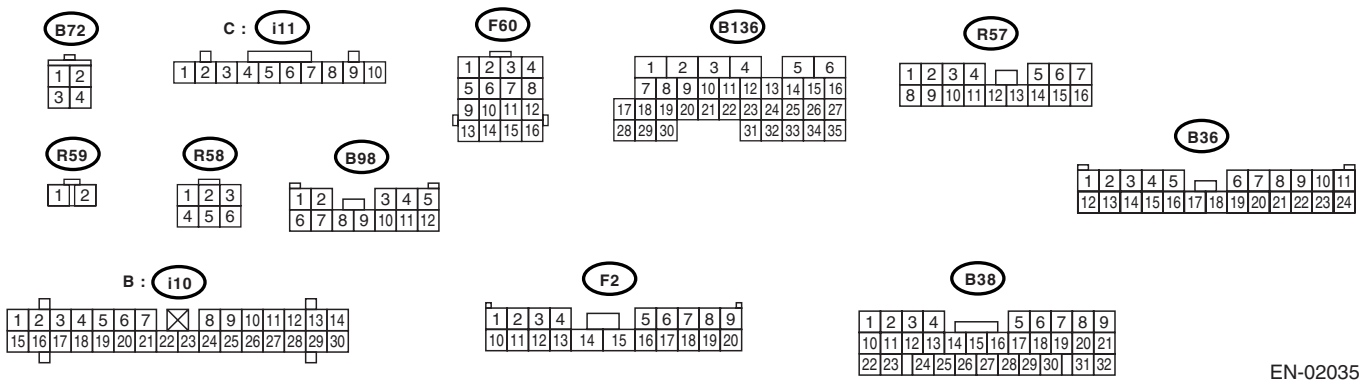
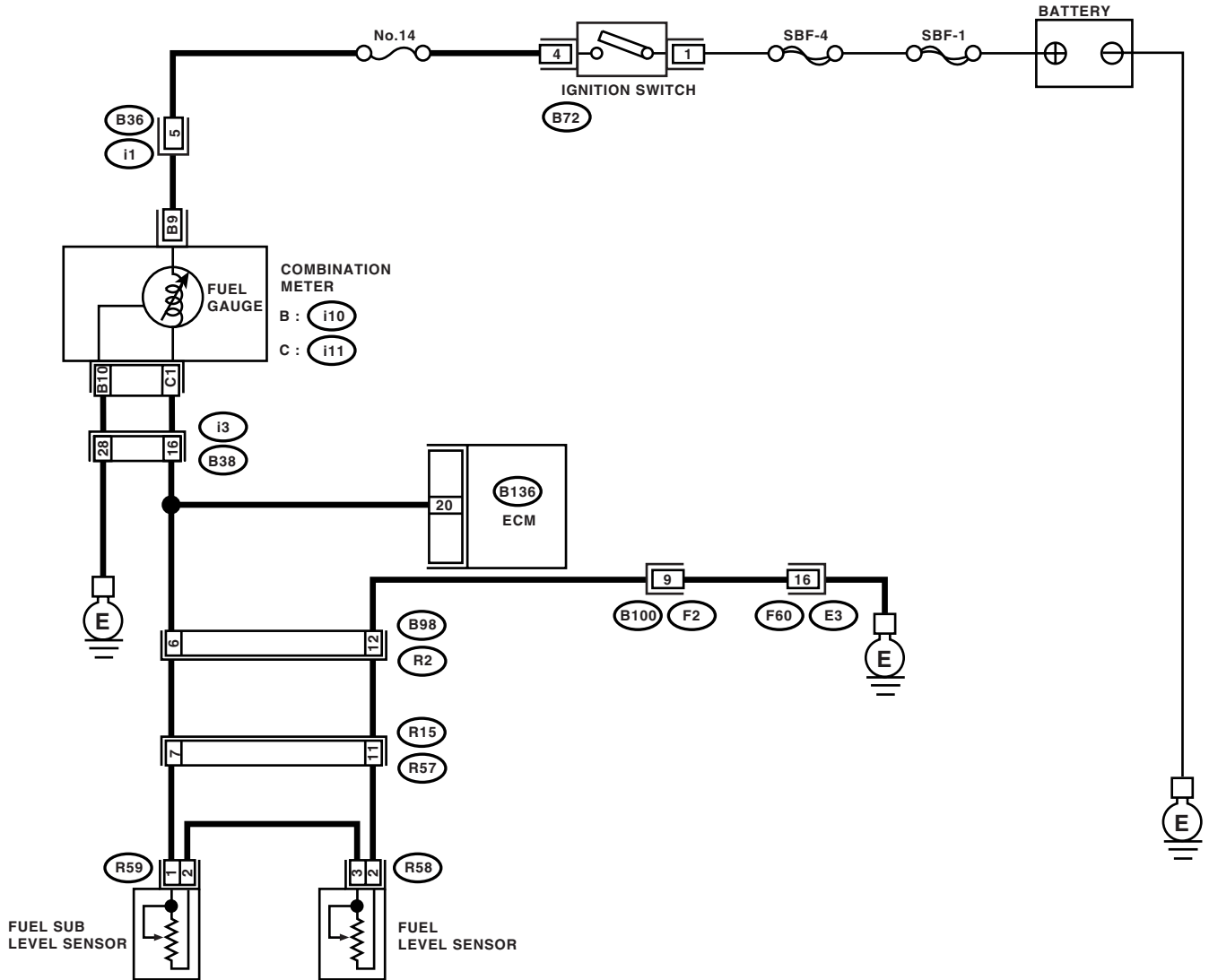

EN-02035

DIAGNOSTIC PROCEDURE WITH DIAGNOSTIC TROUBLE CODE (DTC)

ENGINE (DIAGNOSTICS)

Step	Check	Yes	No
1	CHECK SPEEDOMETER AND TACHOMETER OPERATION IN COMBINATION METER.	Go to step 2.	Repair or replace the combination meter. <Ref. to IDI-3, Combination Meter System.>
2	CHECK INPUT SIGNAL FOR ECM. 1) Turn the ignition switch to ON. (engine OFF) 2) Measure the voltage between ECM connector and chassis ground. Connector & terminal (B136) No. 20 (+) — Chassis ground (-):	Go to step 3.	Even if malfunction indicator light lights up, the circuit has returned to a normal condition at this time. A temporary poor contact of the connector may be the cause. NOTE: In this case, repair the following: <ul style="list-style-type: none"> • Poor contact in fuel pump connector • Poor contact in coupling connector
3	CHECK INPUT VOLTAGE OF ECM. 1) Turn the ignition switch to OFF. 2) Disconnect the combination meter connector (i11) and ECM connector. 3) Turn the ignition switch to ON. 4) Measure the voltage of harness between ECM and chassis ground. Connector & terminal (B136) No. 20 (+) — Chassis ground (-):	Go to step 4.	Repair the battery short circuit between ECM and combination meter connector.
4	CHECK HARNESS BETWEEN ECM AND FUEL TANK CORD. 1) Turn the ignition switch to OFF. 2) Separate the fuel tank cord connector (R57) and rear wiring harness connector (R15). 3) Measure the resistance between ECM and fuel tank cord. Connector & terminal (B136) No. 20 — (R15) No. 7:	Go to step 5.	Repair the open circuit between ECM and fuel tank cord.
5	CHECK HARNESS BETWEEN FUEL TANK CORD AND CHASSIS GROUND. Measure the resistance between fuel tank cord and chassis ground. Connector & terminal (R15) No. 11 — Chassis ground:	Go to step 6.	Repair the open circuit between fuel tank cord and chassis ground. NOTE: In this case, repair the following: Poor contact in coupling connectors
6	CHECK FUEL TANK CORD. 1) Disconnect the connector from fuel level sensor. 2) Measure the resistance between fuel level sensor and coupling connector. Connector & terminal (R57) No. 11 — (R58) No. 2:	Go to step 7.	Repair the open circuit between coupling connector and fuel level sensor.

DIAGNOSTIC PROCEDURE WITH DIAGNOSTIC TROUBLE CODE (DTC)

ENGINE (DIAGNOSTICS)

Step	Check	Yes	No
7 CHECK FUEL TANK CORD. 1) Disconnect the connector from fuel sub level sensor. 2) Measure the resistance between fuel level sensor and fuel sub level sensor. Connector & terminal (R58) No. 3 — (R59) No. 2:	Is the resistance less than 10 Ω ?	Go to step 8 .	Repair the open circuit between fuel level sensor and fuel sub level sensor.
8 CHECK FUEL TANK CORD. Measure the resistance between fuel sub level sensor and coupling connector. Connector & terminal (R57) No. 7 — (R59) No. 1:	Is the resistance less than 10 Ω ?	Go to step 9 .	Repair the open circuit between coupling connector and fuel sub level sensor.
9 CHECK FUEL LEVEL SENSOR. 1) Remove the fuel pump assembly. <Ref. to FU(H4DOTC)-55, Fuel Pump.> 2) While moving the fuel level sensor float up and down, measure the resistance between fuel level sensor terminals. Terminals No. 2 — No. 3:	Is the resistance more than 53 Ω ?	Replace the fuel level sensor. <Ref. to FU(H4DOTC)-57, Fuel Level Sensor.>	Go to step 10 .
10 CHECK FUEL SUB LEVEL SENSOR. 1) Remove the fuel sub level sensor. <Ref. to FU(H4DOTC)-58, Fuel Sub Level Sensor.> 2) While moving the fuel sub level sensor float up and down, measure the resistance between fuel sub level sensor terminals. Terminals No. 1 — No. 2:	Is the resistance more than 45 Ω ?	Replace the fuel sub level sensor. <Ref. to FU(H4DOTC)-58, Fuel Sub Level Sensor.>	Replace the combination meter. <Ref. to IDI-10, Combination Meter Assembly.>

DIAGNOSTIC PROCEDURE WITH DIAGNOSTIC TROUBLE CODE (DTC)

ENGINE (DIAGNOSTICS)

BN:DTC P0464 — FUEL LEVEL SENSOR CIRCUIT INTERMITTENT —

DTC DETECTING CONDITION:

- Two consecutive driving cycles with fault
- GENERAL DESCRIPTION <Ref. to GD(H4DOTC)-163, DTC P0464 — FUEL LEVEL SENSOR CIRCUIT INTERMITTENT —, Diagnostic Trouble Code (DTC) Detecting Criteria.>

CAUTION:

After repair or replacement of faulty parts, conduct Clear Memory Mode <Ref. to EN(H4DOTC)-44, OPERATION, Clear Memory Mode.> and Inspection Mode <Ref. to EN(H4DOTC)-36, OPERATION, Inspection Mode.>.

DIAGNOSTIC PROCEDURE WITH DIAGNOSTIC TROUBLE CODE (DTC)

ENGINE (DIAGNOSTICS)

WIRING DIAGRAM:

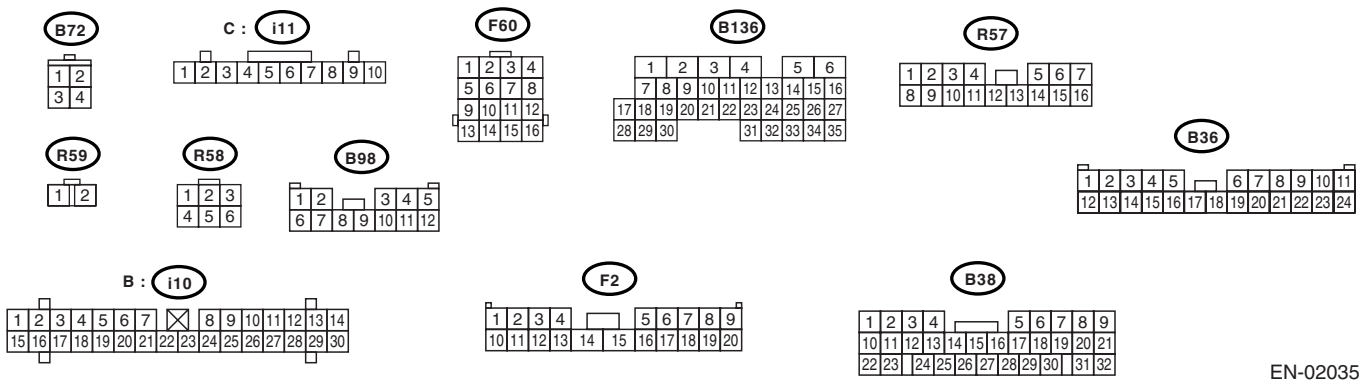
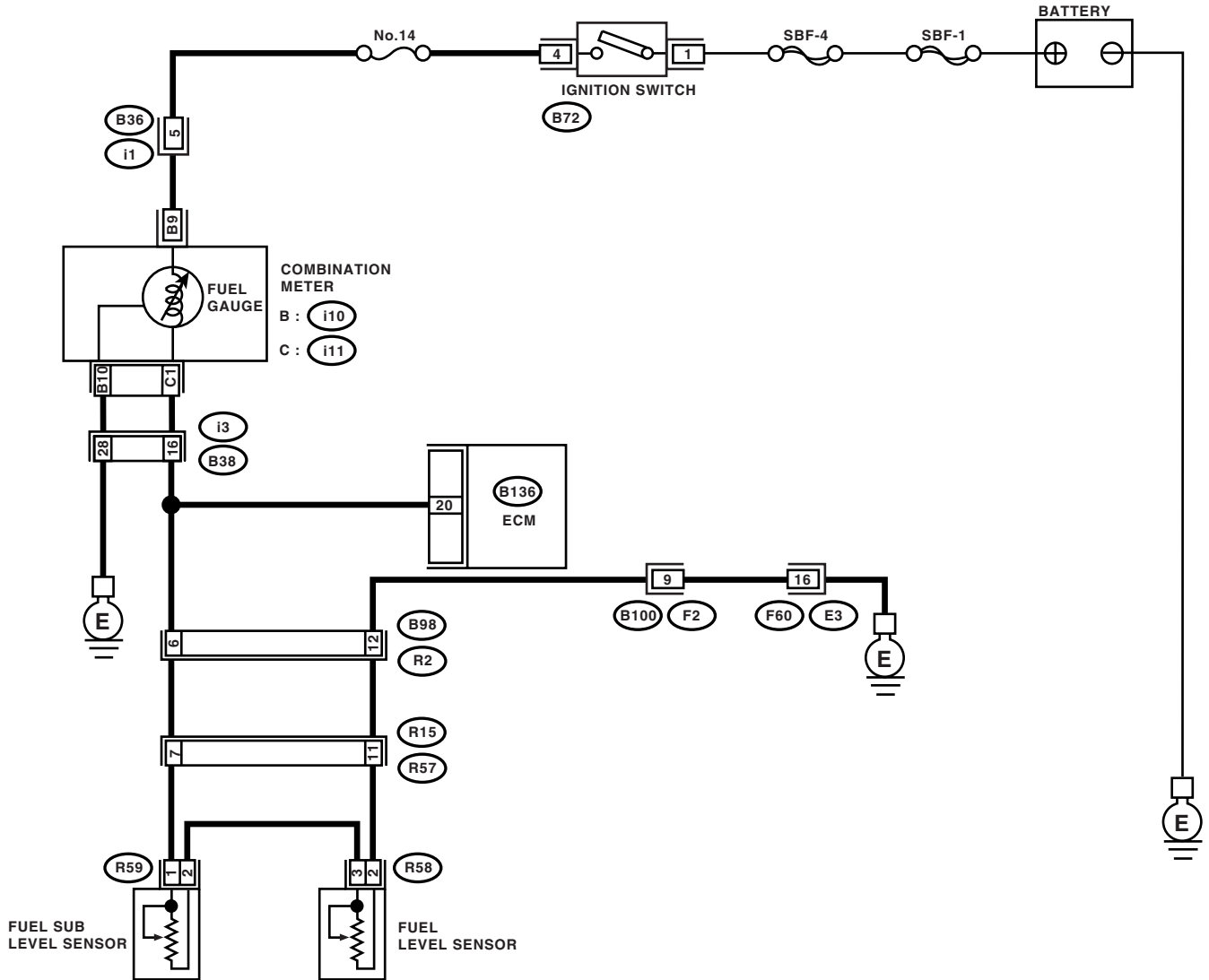

EN-02035

DIAGNOSTIC PROCEDURE WITH DIAGNOSTIC TROUBLE CODE (DTC)

ENGINE (DIAGNOSTICS)

Step	Check	Yes	No
1 CHECK ANY OTHER DTC ON DISPLAY.	Is any other DTC displayed?	Inspect the relevant DTC using "List of Diagnostic Trouble Code (DTC)". <Ref. to EN(H4DOTC)-68, List of Diagnostic Trouble Code (DTC).>	Go to step 2.
2 CHECK FUEL LEVEL SENSOR. 1) Remove the fuel pump assembly. <Ref. to FU(H4DOTC)-55, Fuel Pump.> 2) While moving the fuel level sensor float up and down, make sure that the resistance between fuel level sensor terminals changes smoothly. Terminals No. 3 — No. 2:	Does the resistance change smoothly?	Go to step 3.	Replace the fuel level sensor. <Ref. to FU(H4DOTC)-57, Fuel Level Sensor.>
3 CHECK FUEL SUB LEVEL SENSOR. 1) Remove the fuel sub level sensor. <Ref. to FU(H4DOTC)-58, Fuel Sub Level Sensor.> 2) While moving the fuel sub level sensor float up and down, make sure that the resistance between fuel level sensor terminals changes smoothly. Terminals No. 1 — No. 2:	Does the resistance change smoothly?	Repair the poor contact in ECM, combination meter and coupling connectors.	Replace the fuel sub level sensor. <Ref. to FU(H4DOTC)-58, Fuel Sub Level Sensor.>

BO:DTC P0483 — COOLING FAN RATIONALITY CHECK —

DTC DETECTING CONDITION:

- Two consecutive driving cycles with fault
- GENERAL DESCRIPTION<Ref. to GD(H4DOTC)-166, DTC P0483 — COOLING FAN RATIONALITY CHECK —, Diagnostic Trouble Code (DTC) Detecting Criteria.>

TROUBLE SYMPTOM:

- Occurrence of noise
- Overheating

CAUTION:

After repair or replacement of faulty parts, conduct Clear Memory Mode <Ref. to EN(H4DOTC)-44, OPERATION, Clear Memory Mode.> and Inspection Mode <Ref. to EN(H4DOTC)-36, OPERATION, Inspection Mode.>.

NOTE:

If the vehicle, with the engine idling, is placed very close to a wall or another vehicle, preventing normal cooling function, the OBD system may detect malfunction.

DIAGNOSTIC PROCEDURE WITH DIAGNOSTIC TROUBLE CODE (DTC) ENGINE (DIAGNOSTICS)

WIRING DIAGRAM:

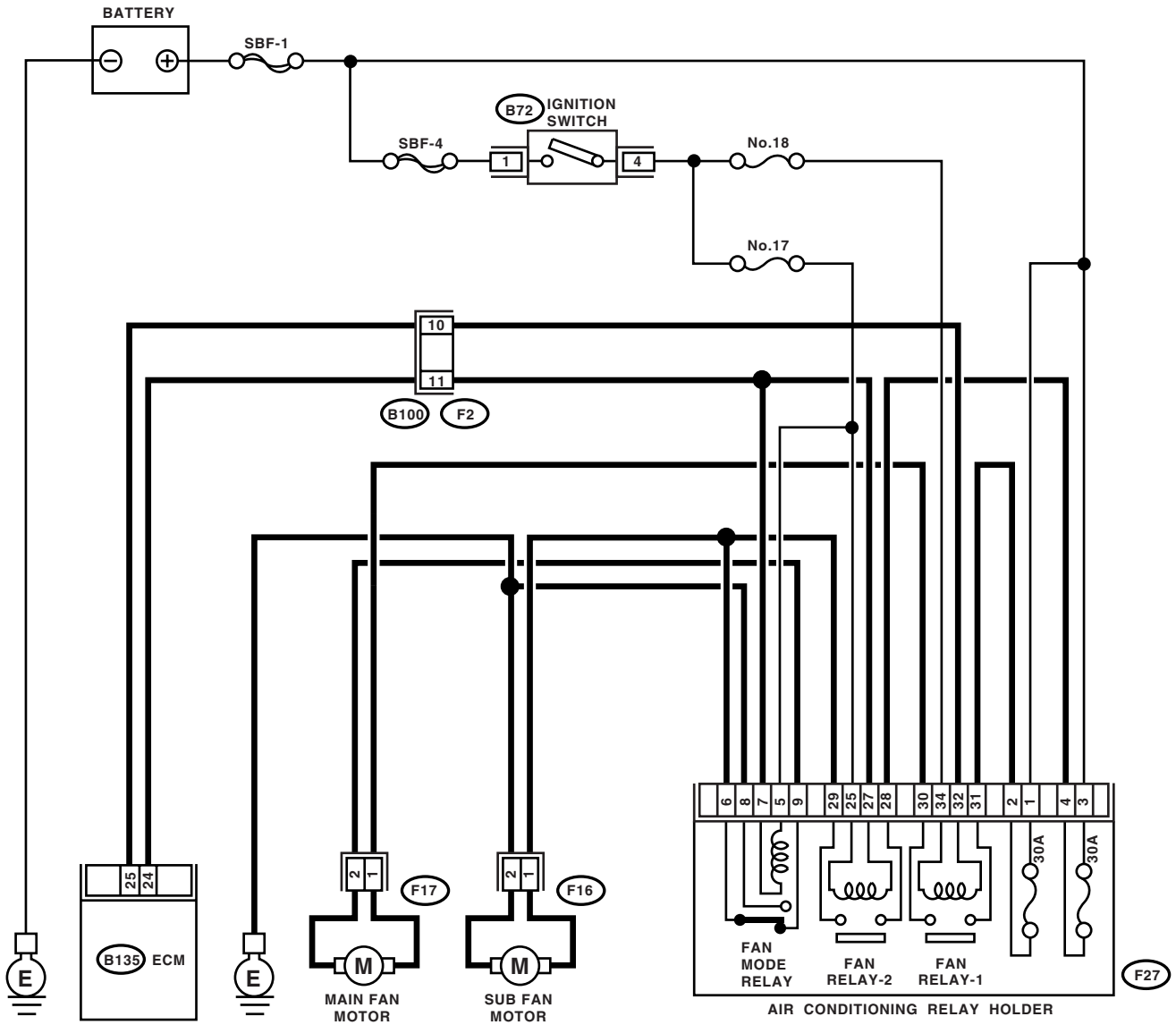

F16

F17



B135

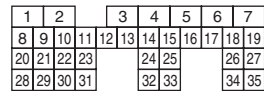

B72



F2

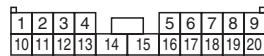

F27

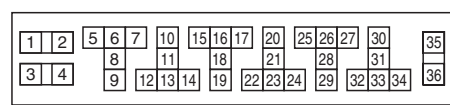

EN-02036

DIAGNOSTIC PROCEDURE WITH DIAGNOSTIC TROUBLE CODE (DTC)

ENGINE (DIAGNOSTICS)

Step	Check	Yes	No
1 CHECK ANY OTHER DTC ON DISPLAY.	Is any other DTC displayed?	Inspect the relevant DTC using "List of Diagnostic Trouble Code (DTC)". <Ref. to EN(H4DOTC)-68, List of Diagnostic Trouble Code (DTC).>	Check the radiator fan, fan motor and thermostat. <Ref. to CO(H4SO)-33, Radiator Main Fan and Fan Motor.> and <Ref. to CO(H4SO)-39, Radiator Sub Fan and Fan Motor.> If thermostat is stuck, replace thermostat.

DIAGNOSTIC PROCEDURE WITH DIAGNOSTIC TROUBLE CODE (DTC)

ENGINE (DIAGNOSTICS)

BP:DTC P0502 — VEHICLE SPEED SENSOR CIRCUIT LOW INPUT —

DTC DETECTING CONDITION:

- Immediately at fault recognition
- GENERAL DESCRIPTION <Ref. to GD(H4DOTC)-167, DTC P0502 — VEHICLE SPEED SENSOR CIRCUIT LOW INPUT —, Diagnostic Trouble Code (DTC) Detecting Criteria.>

CAUTION:

After repair or replacement of faulty parts, conduct Clear Memory Mode <Ref. to EN(H4DOTC)-44, OPERATION, Clear Memory Mode.> and Inspection Mode <Ref. to EN(H4DOTC)-36, OPERATION, Inspection Mode.>.

WIRING DIAGRAM:

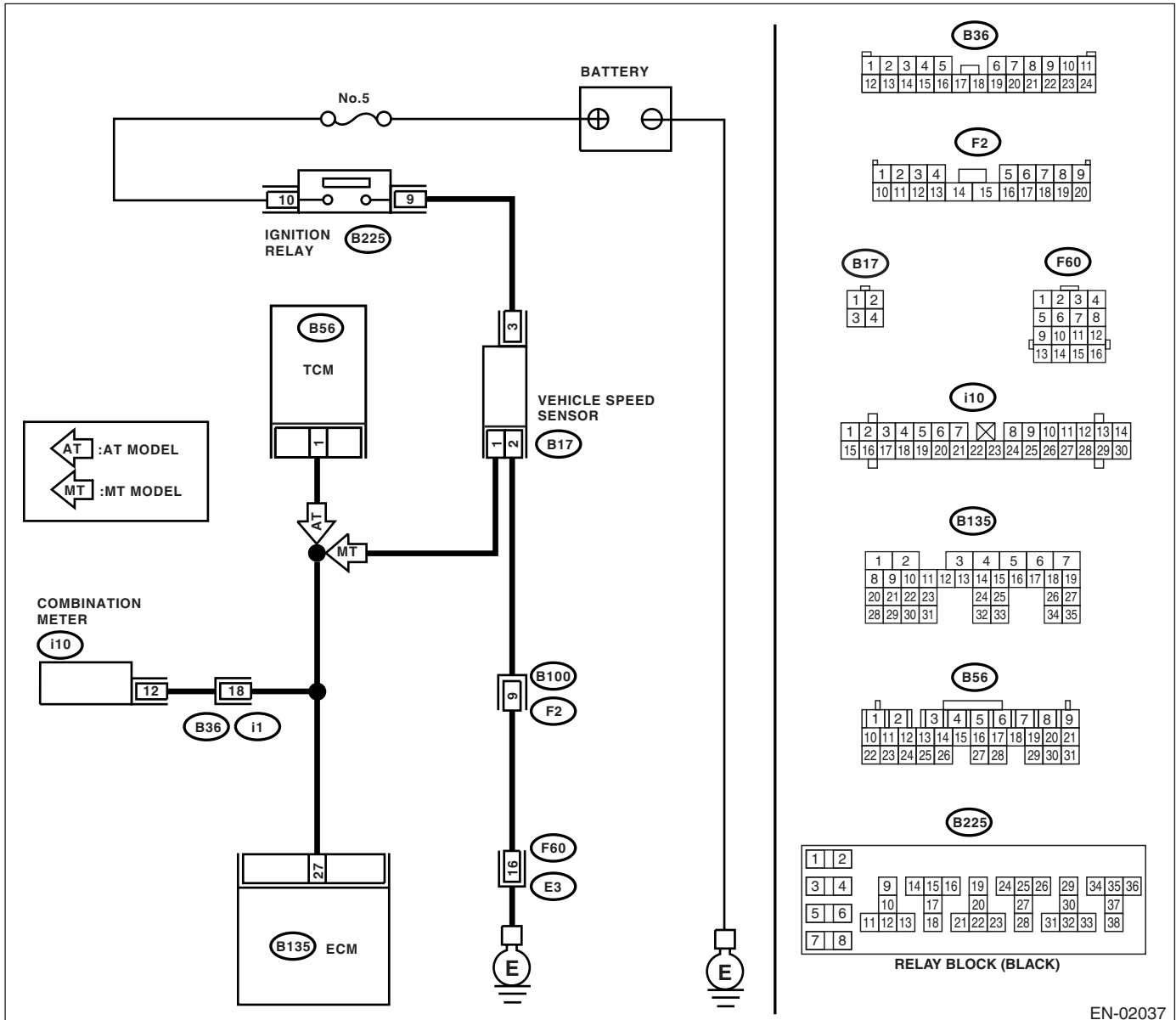

EN-02037

DIAGNOSTIC PROCEDURE WITH DIAGNOSTIC TROUBLE CODE (DTC)

ENGINE (DIAGNOSTICS)

Step	Check	Yes	No
1 CHECK HARENESS BETWEEN VEHICLE SPEED SENSOR AND ECM CONNECTOR. 1) Turn the ignition switch to OFF. 2) Disconnect the connectors from vehicle speed sensor and ECM. 3) Measure the resistance of harness between vehicle speed sensor connector and chassis ground. Connector & terminal (B17) No. 1 — Chassis ground:	Is the resistance more than 1 MΩ?	Go to step 2.	Repair the ground short circuit in harness between vehicle speed sensor and ECM connector.
2 CHECK POOR CONTACT. Check poor contact in the vehicle speed sensor connector.	Is there poor contact in the vehicle speed sensor connector?	Repair poor contact in the vehicle speed sensor connector.	Replace the vehicle speed sensor. <Ref. to 5MT-40, Vehicle Speed Sensor.>

DIAGNOSTIC PROCEDURE WITH DIAGNOSTIC TROUBLE CODE (DTC)

ENGINE (DIAGNOSTICS)

BQ:DTC P0503 — VEHICLE SPEED SENSOR INTERMITTENT/ERRATIC/HIGH — DTC DETECTING CONDITION:

- Immediately at fault recognition
- GENERAL DESCRIPTION <Ref. to GD(H4DOTC)-169, DTC P0503 — VEHICLE SPEED SENSOR INTERMITTENT/ERRATIC/HIGH —, Diagnostic Trouble Code (DTC) Detecting Criteria.>

CAUTION:

After repair or replacement of faulty parts, conduct Clear Memory Mode <Ref. to EN(H4DOTC)-44, OPERATION, Clear Memory Mode.> and Inspection Mode <Ref. to EN(H4DOTC)-36, OPERATION, Inspection Mode.>.

WIRING DIAGRAM:

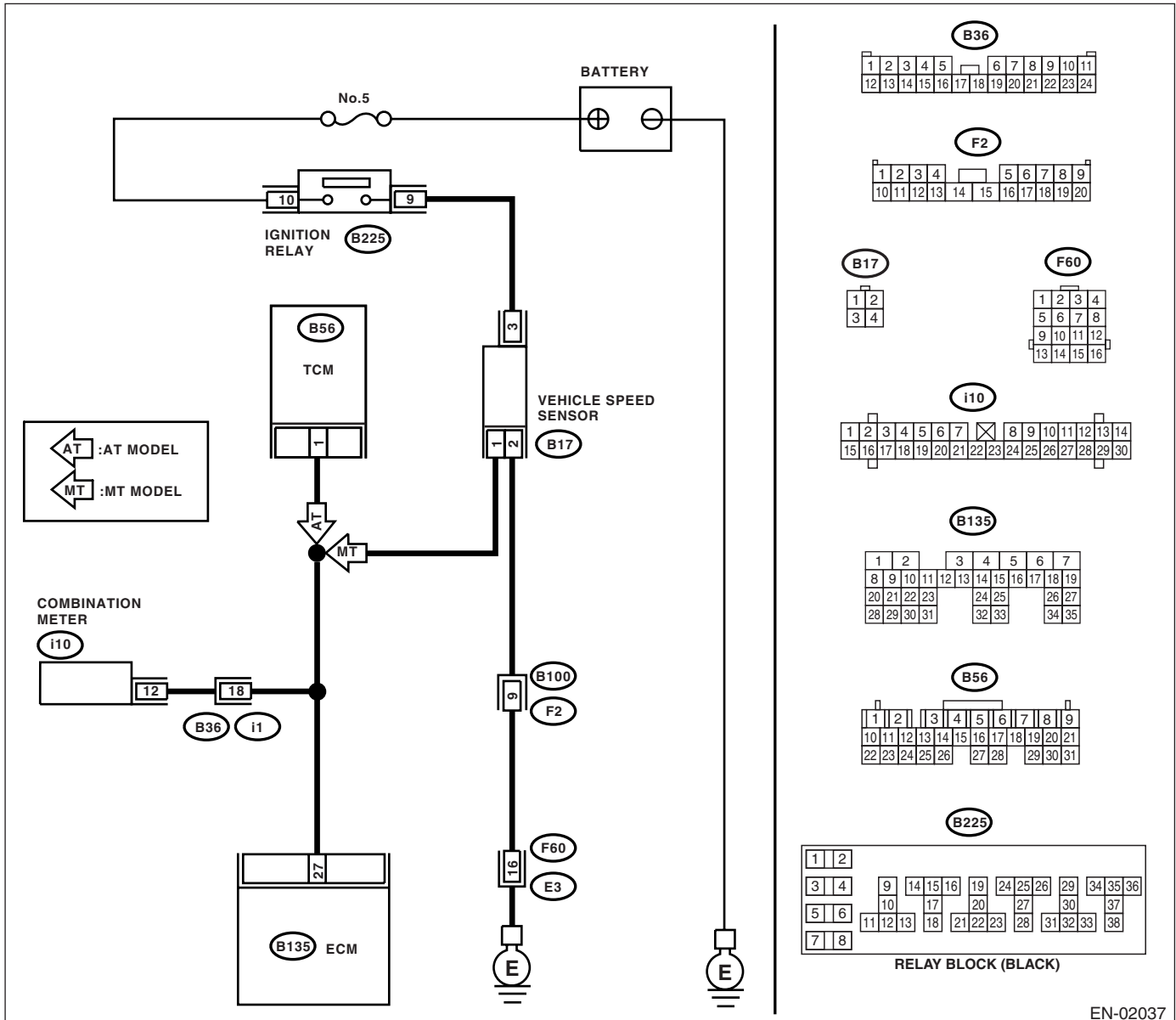

EN-02037

DIAGNOSTIC PROCEDURE WITH DIAGNOSTIC TROUBLE CODE (DTC)

ENGINE (DIAGNOSTICS)

Step	Check	Yes	No
1 CHECK SPEEDOMETER OPERATION IN COMBINATION METER.	Does the speedometer operate normally?	Go to step 2.	Check the speedometer. <Ref. to IDI-12, Speedometer.>
2 CHECK HARNESS BETWEEN ECM AND COMBINATION METER CONNECTOR. 1) Turn the ignition switch to OFF. 2) Disconnect the connector from combination meter. 3) Measure the resistance between ECM and combination meter. Connector & terminal (B135) No. 27 — (i10) No. 12:	Is the resistance less than 10 Ω ?	Repair the poor contact in ECM connector.	Repair the harness and connector. NOTE: In this case, repair the following: <ul style="list-style-type: none">• Open circuit in harness between ECM and combination meter connector• Poor contact in ECM connector• Poor contact in combination meter connector• Poor contact in coupling connector

DIAGNOSTIC PROCEDURE WITH DIAGNOSTIC TROUBLE CODE (DTC)

ENGINE (DIAGNOSTICS)

BR:DTC P0506 — IDLE CONTROL SYSTEM RPM LOWER THAN EXPECTED — DTC DETECTING CONDITION:

- Two consecutive driving cycles with fault
- GENERAL DESCRIPTION <Ref. to GD(H4DOTC)-171, DTC P0506 — IDLE CONTROL SYSTEM RPM LOWER THAN EXPECTED —, Diagnostic Trouble Code (DTC) Detecting Criteria.>

TROUBLE SYMPTOM:

- Engine is difficult to start.
- Engine does not start.
- Erroneous idling
- Engine stalls.

CAUTION:

After repair or replacement of faulty parts, conduct Clear Memory Mode <Ref. to EN(H4DOTC)-44, OPERATION, Clear Memory Mode.> and Inspection Mode <Ref. to EN(H4DOTC)-36, OPERATION, Inspection Mode.>.

DIAGNOSTIC PROCEDURE WITH DIAGNOSTIC TROUBLE CODE (DTC) ENGINE (DIAGNOSTICS)

WIRING DIAGRAM:

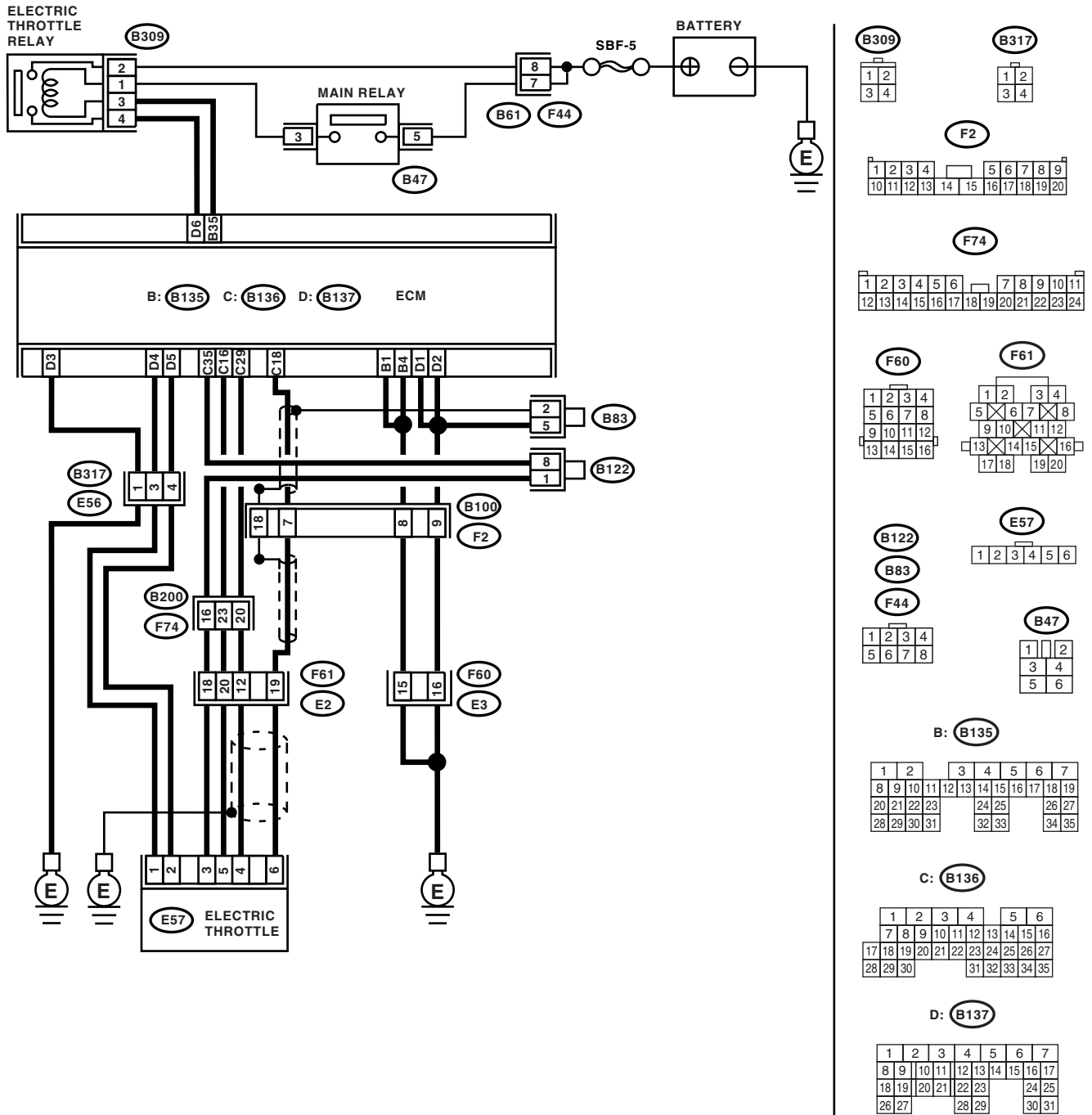

EN-02025

DIAGNOSTIC PROCEDURE WITH DIAGNOSTIC TROUBLE CODE (DTC)

ENGINE (DIAGNOSTICS)

Step	Check	Yes	No
1 CHECK ANY OTHER DTC ON DISPLAY.	Is any other DTC displayed?	Inspect the relevant DTC using "List of Diagnostic Trouble Code (DTC)". <Ref. to EN(H4DOTC)-68, List of Diagnostic Trouble Code (DTC).> NOTE: In this case, it is not necessary to inspect DTC P0506.	Go to step 2.
2 CHECK AIR CLEANER ELEMENT. 1) Turn the ignition switch to OFF. 2) Check air cleaner element.	Is there excessive clogging on air cleaner element.	Replace the air cleaner element.<Ref. to IN(H4DOTC)-7, Air Cleaner.>	Go to step 3.
3 CHECK ELECTRIC THROTTLE. 1) Turn the ignition switch to OFF. 2) Remove the electric throttle. 3) Check the electric throttle.	Are there foreign particles in electric throttle?	Remove the foreign particles from electric throttle.	Perform the diagnosis of DTC P2101.

BS:DTC P0507 — IDLE CONTROL SYSTEM RPM HIGHER THAN EXPECTED — DTC DETECTING CONDITION:

- Two consecutive driving cycles with fault
- GENERAL DESCRIPTION <Ref. to GD(H4DOTC)-173, DTC P0507 — IDLE CONTROL SYSTEM RPM HIGHER THAN EXPECTED —, Diagnostic Trouble Code (DTC) Detecting Criteria.>

TROUBLE SYMPTOM:

Engine keeps running at higher revolution than specified idling revolution.

CAUTION:

After repair or replacement of faulty parts, conduct Clear Memory Mode <Ref. to EN(H4DOTC)-44, OPERATION, Clear Memory Mode.> and Inspection Mode <Ref. to EN(H4DOTC)-36, OPERATION, Inspection Mode.>.

DIAGNOSTIC PROCEDURE WITH DIAGNOSTIC TROUBLE CODE (DTC) ENGINE (DIAGNOSTICS)

WIRING DIAGRAM:

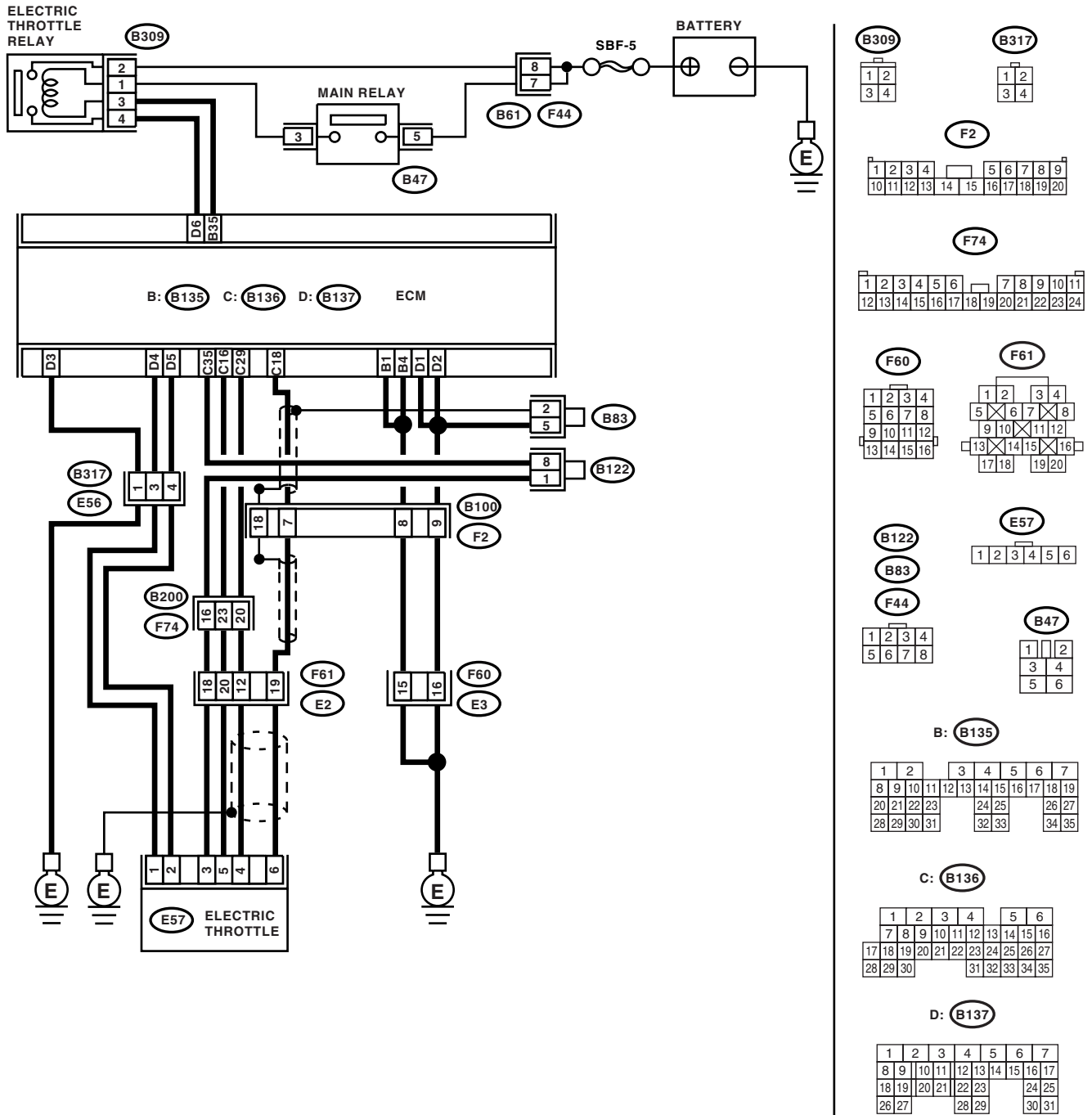

EN-02025

DIAGNOSTIC PROCEDURE WITH DIAGNOSTIC TROUBLE CODE (DTC)

ENGINE (DIAGNOSTICS)

Step	Check	Yes	No
1 CHECK ANY OTHER DTC ON DISPLAY.	Is any other DTC displayed?	Inspect the relevant DTC using "List of Diagnostic Trouble Code (DTC)". <Ref. to EN(H4DOTC)-68, List of Diagnostic Trouble Code (DTC).> NOTE: In this case, it is not necessary to inspect DTC P0507.	Go to step 2.
2 CHECK AIR INTAKE SYSTEM. 1) Turn the ignition switch to ON. 2) Start the engine, and idle it. 3) Check the following items. <ul style="list-style-type: none">• Loose installation of intake manifold and throttle body• Cracks of intake manifold gasket and throttle body gasket• Disconnections of vacuum hoses	Is there a fault in air intake system?	Repair the air suction and leaks.	Go to step 3.
3 CHECK ELECTRIC THROTTLE. 1) Turn the ignition switch to OFF. 2) Remove the electric throttle. 3) Check the electric throttle.	Are there foreign particles in electric throttle?	Remove the foreign particles from electric throttle.	Perform the diagnosis of DTC P2102.

DIAGNOSTIC PROCEDURE WITH DIAGNOSTIC TROUBLE CODE (DTC)

ENGINE (DIAGNOSTICS)

BT:DTC P0512 — STARTER REQUEST CIRCUIT —

DTC DETECTING CONDITION:

- Immediately at fault recognition
- GENERAL DESCRIPTION <Ref. to GD(H4DOTC)-175, DTC P0512 — STARTER REQUEST CIRCUIT —, Diagnostic Trouble Code (DTC) Detecting Criteria.>

TROUBLE SYMPTOM:

Failure of engine to start

CAUTION:

After repair or replacement of faulty parts, conduct Clear Memory Mode <Ref. to EN(H4DOTC)-44, OPERATION, Clear Memory Mode.> and Inspection Mode <Ref. to EN(H4DOTC)-36, OPERATION, Inspection Mode.>.

DIAGNOSTIC PROCEDURE WITH DIAGNOSTIC TROUBLE CODE (DTC)

ENGINE (DIAGNOSTICS)

WIRING DIAGRAM:

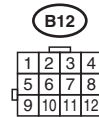
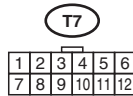
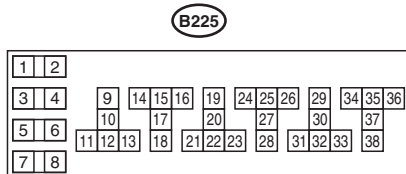
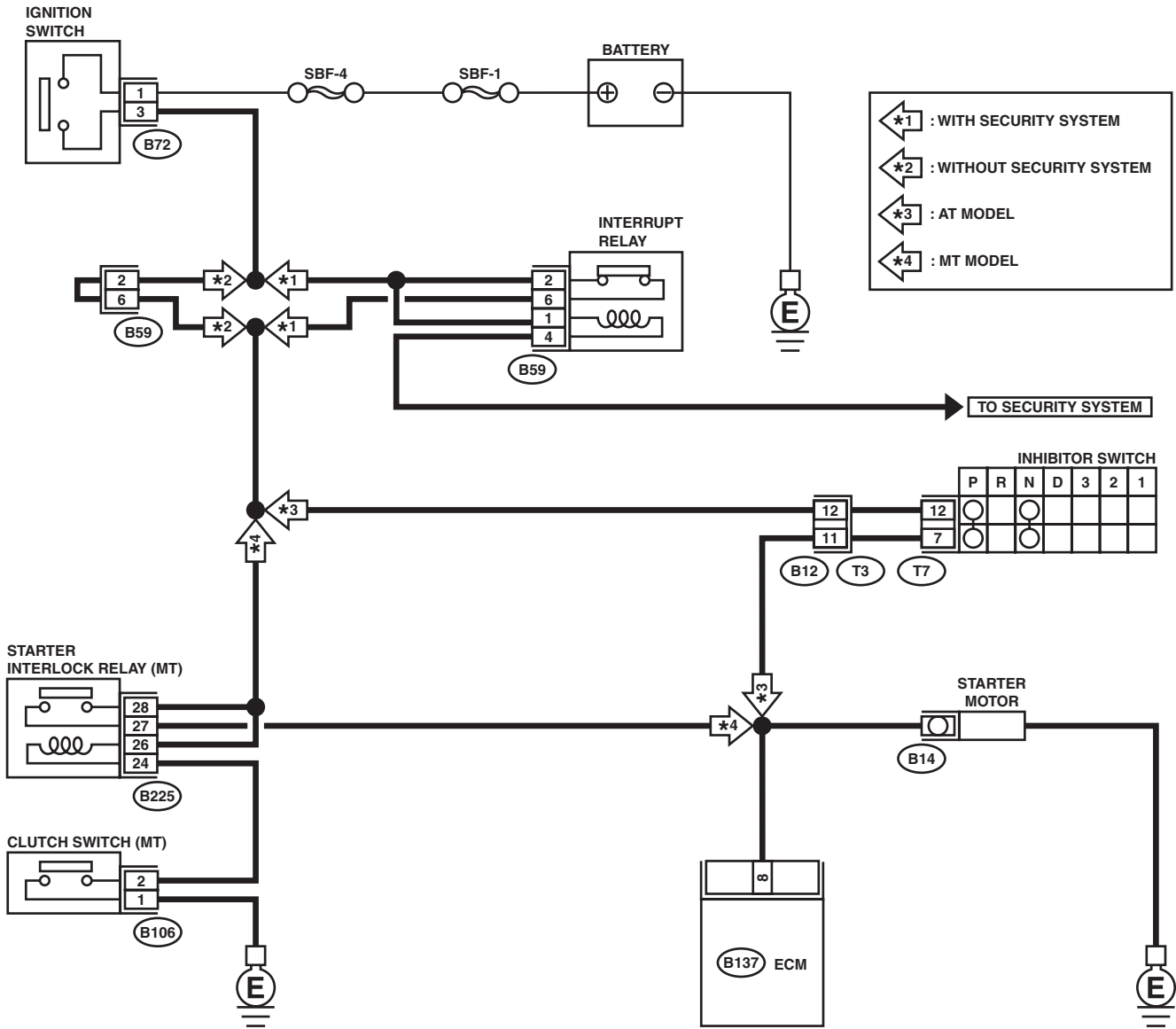

EN-02015

DIAGNOSTIC PROCEDURE WITH DIAGNOSTIC TROUBLE CODE (DTC)

ENGINE (DIAGNOSTICS)

Step	Check	Yes	No
1 CHECK OPERATION OF STARTER MOTOR.	Does the starter motor operate when ignition switch is turned to ON?	Repair the battery short circuit in starter motor circuit. After repair, replace the ECM. <Ref. to FU(H4DOTC)-42, Engine Control Module (ECM).>	Check the starter motor circuit. <Ref. to EN(H4DOTC)-57, STARTER MOTOR CIRCUIT, Diagnostics for Engine Starting Failure.>

BU:DTC P0519 — IDLE CONTROL SYSTEM MALFUNCTION (FAIL-SAFE) —

DTC DETECTING CONDITION:

- Immediately at fault recognition
- GENERAL DESCRIPTION <Ref. to GD(H4DOTC)-176, DTC P0519 — IDLE CONTROL SYSTEM MALFUNCTION (FAIL-SAFE) —, Diagnostic Trouble Code (DTC) Detecting Criteria.>

TROUBLE SYMPTOM:

- Engine keeps running at higher revolution than specified idling revolution.
- Fuel is cut according to fail-safe function.

CAUTION:

After repair or replacement of faulty parts, conduct Clear Memory Mode <Ref. to EN(H4DOTC)-44, OPERATION, Clear Memory Mode.> and Inspection Mode <Ref. to EN(H4DOTC)-36, OPERATION, Inspection Mode.>.

DIAGNOSTIC PROCEDURE WITH DIAGNOSTIC TROUBLE CODE (DTC)

ENGINE (DIAGNOSTICS)

	Step	Check	Yes	No
1	CHECK ANY OTHER DTC ON DISPLAY.	Is any other DTC displayed?	Inspect the relevant DTC using "List of Diagnostic Trouble Code (DTC)". <Ref. to EN(H4DOTC)-68, List of Diagnostic Trouble Code (DTC).> NOTE: In this case, it is not necessary to inspect DTC P0519.	Go to step 2.
2	CHECK AIR INTAKE SYSTEM. 1) Turn the ignition switch to ON. 2) Start the engine, and idle it. 3) Check the following items. <ul style="list-style-type: none">• Loose installation of intake manifold and throttle body• Cracks of intake manifold gasket and throttle body gasket• Disconnections of vacuum hoses	Is there a fault in air intake system?	Repair the air suction and leaks.	Go to step 3.
3	CHECK ELECTRIC THROTTLE. 1) Turn the ignition switch to OFF. 2) Remove the electric throttle. 3) Check the electric throttle.	Are there foreign particles in electric throttle?	Remove the foreign particles from electric throttle.	Perform the diagnosis of DTC P2102.

DIAGNOSTIC PROCEDURE WITH DIAGNOSTIC TROUBLE CODE (DTC)

ENGINE (DIAGNOSTICS)

BV:DTC P0545 — EXHAUST GAS TEMPERATURE SENSOR CIRCUIT LOW-BANK 1 —

DTC DETECTING CONDITION:

- Immediately at fault recognition
- GENERAL DESCRIPTION <Ref. to GD(H4DOTC)-177, DTC P0545 — EXHAUST GAS TEMPERATURE SENSOR CIRCUIT LOW-BANK 1 —, Diagnostic Trouble Code (DTC) Detecting Criteria.>

TROUBLE SYMPTOM:

- Hard to start
- Erroneous idling
- Poor driving performance

CAUTION:

After repair or replacement of faulty parts, conduct Clear Memory Mode <Ref. to EN(H4DOTC)-44, OPERATION, Clear Memory Mode.> and Inspection Mode <Ref. to EN(H4DOTC)-36, OPERATION, Inspection Mode.>.

WIRING DIAGRAM:

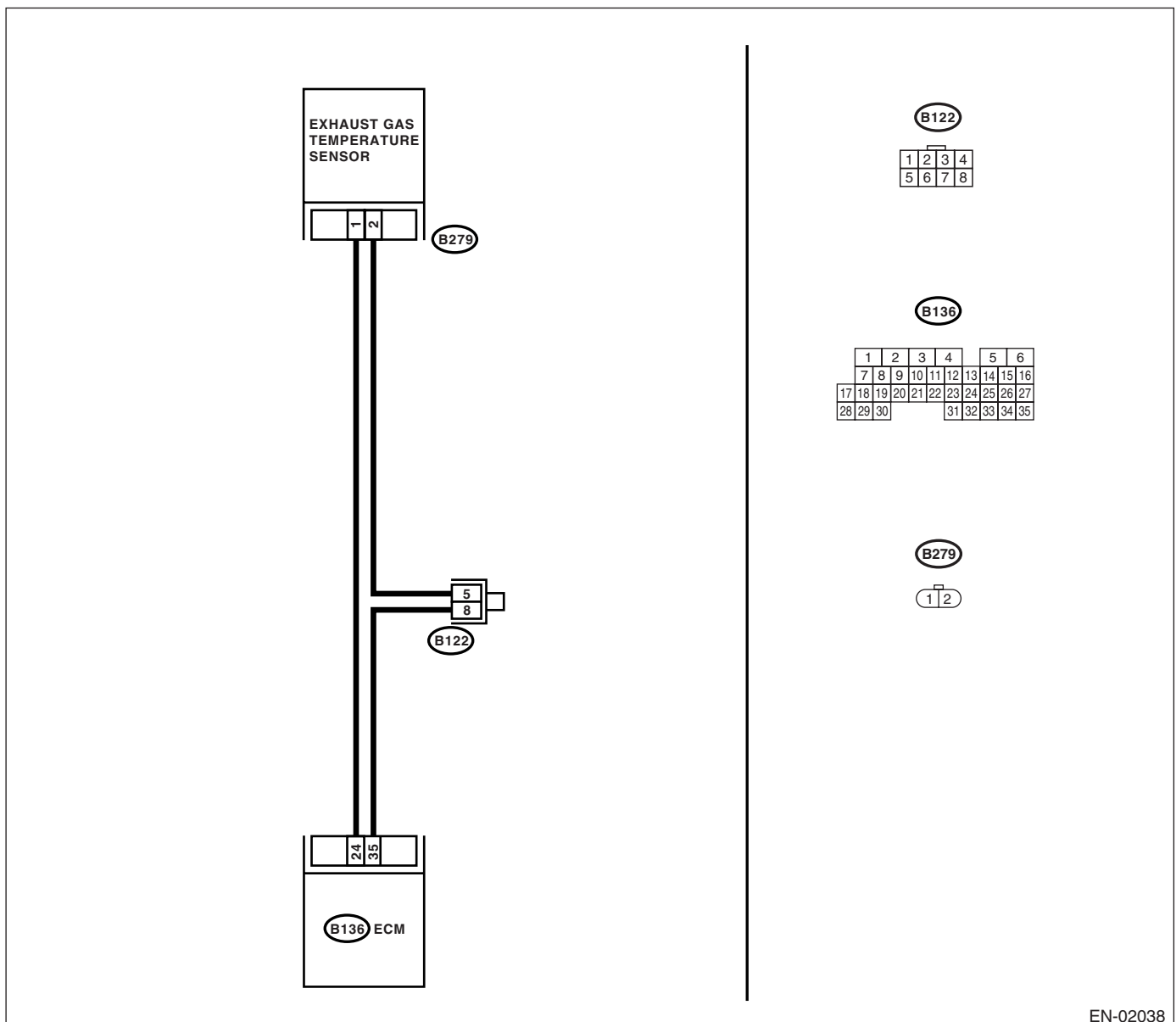

EN-02038

DIAGNOSTIC PROCEDURE WITH DIAGNOSTIC TROUBLE CODE (DTC)

ENGINE (DIAGNOSTICS)

Step	Check	Yes	No
1 CHECK CURRENT DATA. 1) Start the engine. 2) Read the data of exhaust gas temperature sensor signal using Subaru Select Monitor or OBD-II general scan tool. NOTE: • Subaru Select Monitor For detailed operation procedure, refer to the "READ CURRENT DATA FOR ENGINE". <Ref. to EN(H4DOTC)-29, Subaru Select Monitor.> • OBD-II general scan tool For detailed operation procedures, refer to the OBD-II General Scan Tool Instruction Manual.	Is the temperature more than 1200°C (2192°F)?	Go to step 2.	Repair the poor contact. NOTE: In this case, repair the following: • Poor contact in exhaust gas temperature sensor • Poor contact in ECM • Poor contact in joint connector
2 CHECK HARNESS BETWEEN EXHAUST GAS TEMPERATURE SENSOR AND ECM CONNECTOR. 1) Turn the ignition switch to OFF. 2) Disconnect the connector from exhaust gas temperature sensor. 3) Turn the ignition switch to ON. 4) Read the data of exhaust gas temperature sensor signal using Subaru Select Monitor or OBD-II general scan tool. NOTE: • Subaru Select Monitor For detailed operation procedure, refer to the "READ CURRENT DATA FOR ENGINE". <Ref. to EN(H4DOTC)-29, Subaru Select Monitor.> • OBD-II general scan tool For detailed operation procedures, refer to the OBD-II General Scan Tool Instruction Manual.	Is the temperature less than 372°C (702°F)?	Replace the exhaust gas temperature sensor. <Ref. to FU(H4DOTC)-41, Exhaust Temperature Sensor.>	Repair the ground short circuit in harness between exhaust gas temperature sensor and ECM connector.

DIAGNOSTIC PROCEDURE WITH DIAGNOSTIC TROUBLE CODE (DTC)

ENGINE (DIAGNOSTICS)

BW:DTC P0546 — EXHAUST GAS TEMPERATURE SENSOR CIRCUIT HIGH-BANK 1 —

DTC DETECTING CONDITION:

- Immediately at fault recognition
- GENERAL DESCRIPTION <Ref. to GD(H4DOTC)-179, DTC P0546 — EXHAUST GAS TEMPERATURE SENSOR CIRCUIT HIGH-BANK 1 —, Diagnostic Trouble Code (DTC) Detecting Criteria.>

TROUBLE SYMPTOM:

- Hard to start
- Erroneous idling
- Poor driving performance

CAUTION:

After repair or replacement of faulty parts, conduct Clear Memory Mode <Ref. to EN(H4DOTC)-44, OPERATION, Clear Memory Mode.> and Inspection Mode <Ref. to EN(H4DOTC)-36, OPERATION, Inspection Mode.>.

WIRING DIAGRAM:

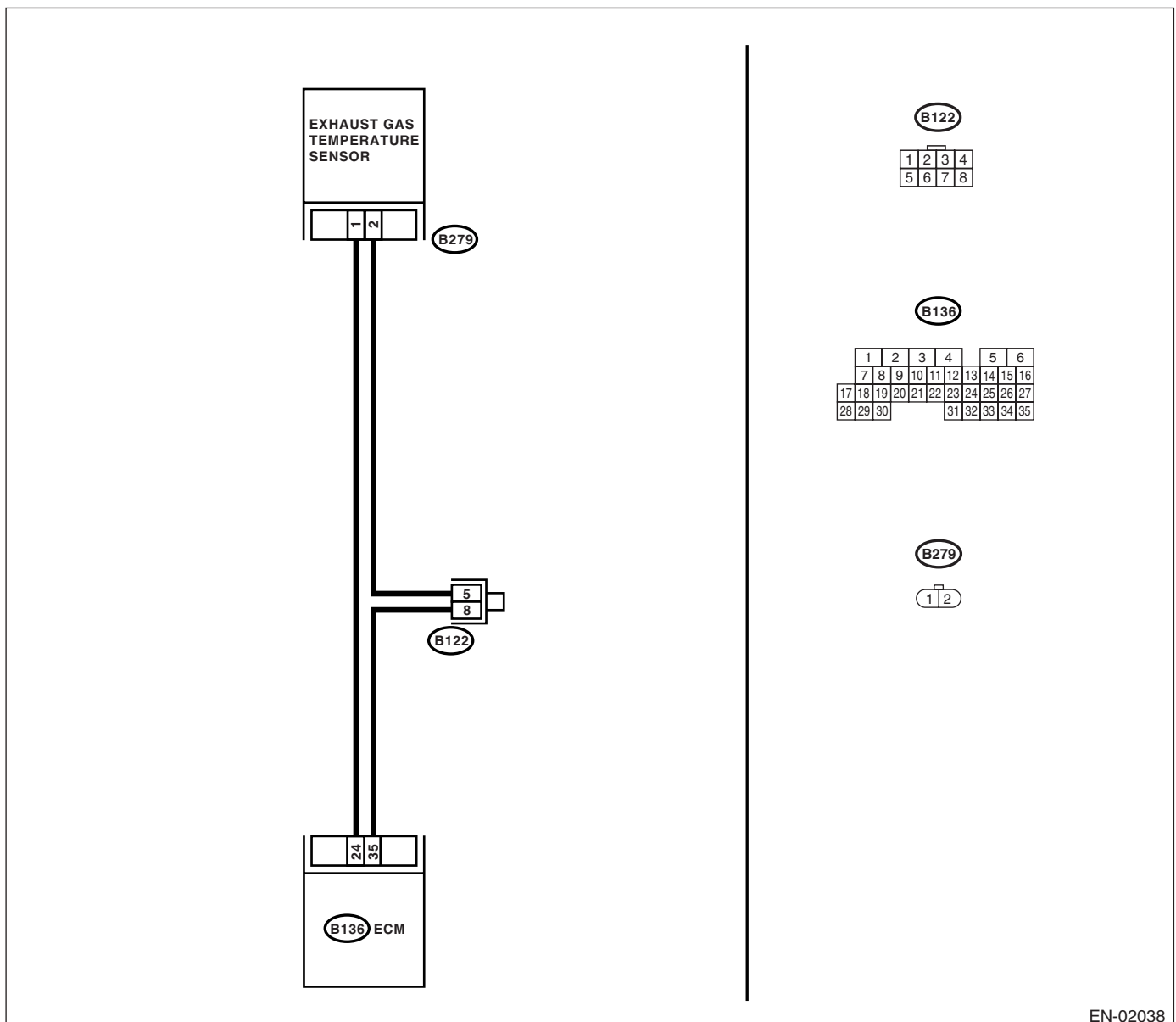

EN-02038

DIAGNOSTIC PROCEDURE WITH DIAGNOSTIC TROUBLE CODE (DTC)

ENGINE (DIAGNOSTICS)

Step	Check	Yes	No
<p>1</p> <p>CHECK CURRENT DATA.</p> <p>1) Start the engine.</p> <p>2) Read the data of exhaust gas temperature sensor signal using Subaru Select Monitor or OBD-II general scan tool.</p> <p>NOTE:</p> <ul style="list-style-type: none"> • Subaru Select Monitor <p>For detailed operation procedure, refer to the "READ CURRENT DATA FOR ENGINE". <Ref. to EN(H4DOTC)-29, Subaru Select Monitor.></p> <ul style="list-style-type: none"> • OBD-II general scan tool <p>For detailed operation procedures, refer to the OBD-II General Scan Tool Instruction Manual.</p>	<p>Is the temperature less than 372°C (702°F)?</p>	<p>Go to step 2.</p>	<p>Repair the poor contact.</p> <p>NOTE:</p> <p>In this case, repair the following:</p> <ul style="list-style-type: none"> • Poor contact in exhaust gas temperature sensor • Poor contact in ECM • Poor contact in joint connector
<p>2</p> <p>CHECK HARNESS BETWEEN EXHAUST GAS TEMPERATURE SENSOR AND ECM CONNECTOR.</p> <p>1) Turn the ignition switch to OFF.</p> <p>2) Disconnect the connector from exhaust gas temperature sensor.</p> <p>3) Measure the voltage between exhaust gas temperature sensor connector and engine ground.</p> <p>Connector & terminal (B279) No. 1 (+) — Engine ground (-):</p>	<p>Is the voltage more than 10 V?</p>	<p>Repair the battery short circuit in harness between ECM and exhaust gas temperature sensor connector.</p>	<p>Go to step 3.</p>
<p>3</p> <p>CHECK HARNESS BETWEEN EXHAUST GAS TEMPERATURE SENSOR AND ECM CONNECTOR.</p> <p>1) Turn the ignition switch to ON.</p> <p>2) Measure the voltage between exhaust gas temperature sensor connector and engine ground.</p> <p>Connector & terminal (B279) No. 1 (+) — Engine ground (-):</p>	<p>Is the voltage more than 10 V?</p>	<p>Repair the battery short circuit in harness between ECM and exhaust gas temperature sensor connector.</p>	<p>Go to step 4.</p>
<p>4</p> <p>CHECK HARNESS BETWEEN EXHAUST GAS TEMPERATURE SENSOR AND ECM CONNECTOR.</p> <p>Measure the voltage between exhaust gas temperature sensor connector and engine ground.</p> <p>Connector & terminal (B279) No. 1 (+) — Engine ground (-):</p>	<p>Is the voltage more than 4 V?</p>	<p>Go to step 5.</p>	<p>Repair the harness and connector.</p> <p>NOTE:</p> <p>In this case, repair the following:</p> <ul style="list-style-type: none"> • Open circuit in harness between ECM and exhaust gas temperature sensor connector • Poor contact in exhaust gas temperature sensor connector • Poor contact in ECM connector • Poor contact in joint connector

DIAGNOSTIC PROCEDURE WITH DIAGNOSTIC TROUBLE CODE (DTC)

ENGINE (DIAGNOSTICS)

Step	Check	Yes	No
<p>5</p> <p>CHECK HARNESS BETWEEN EXHAUST GAS TEMPERATURE SENSOR AND ECM CONNECTOR.</p> <p>1) Turn the ignition switch to OFF.</p> <p>2) Measure the resistance of harness between exhaust gas temperature sensor connector and engine ground.</p> <p>Connector & terminal (B279) No. 2 — Engine ground:</p>	<p>Is the resistance less than 5 Ω?</p>	<p>Replace the exhaust gas temperature sensor. <Ref. to FU(H4DOTC)-41, Exhaust Temperature Sensor.></p>	<p>Repair the harness and connector.</p> <p>NOTE: In this case, repair the following:</p> <ul style="list-style-type: none">• Open circuit in harness between ECM and exhaust gas temperature sensor connector• Poor contact in exhaust gas temperature sensor connector• Poor contact in ECM connector• Poor contact in joint connector

BX:DTC P0600 — IMPROPER CAN COMMUNICATION —

DTC DETECTING CONDITION:

Immediately at fault recognition

CAUTION:

After repair or replacement of faulty parts, conduct Clear Memory Mode <Ref. to EN(H4DOTC)-44, OPERATION, Clear Memory Mode.> and Inspection Mode <Ref. to EN(H4DOTC)-36, Inspection Mode.>.

WIRING DIAGRAM:

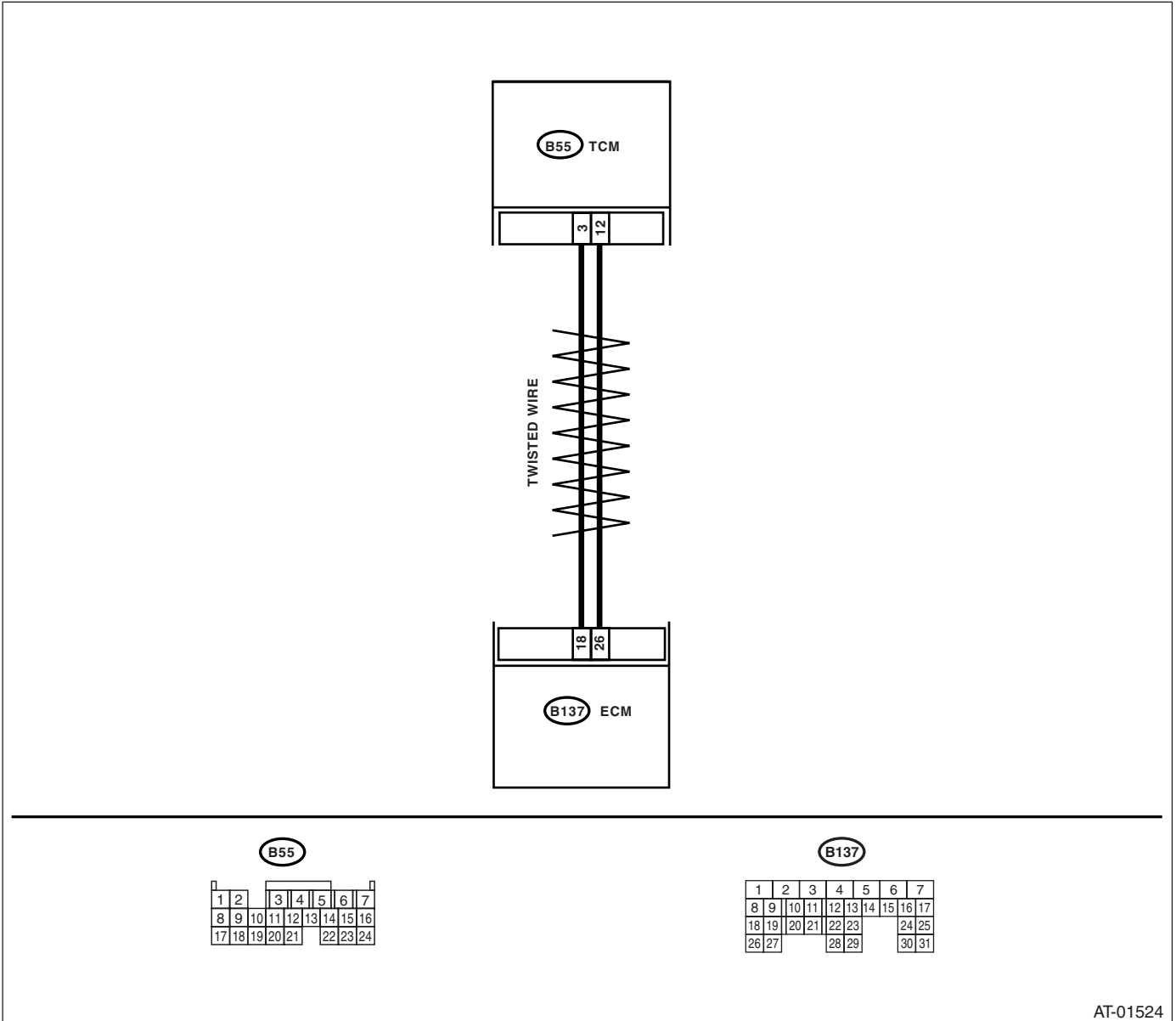

AT-01524

DIAGNOSTIC PROCEDURE WITH DIAGNOSTIC TROUBLE CODE (DTC)

ENGINE (DIAGNOSTICS)

	Step	Check	Yes	No
1	CHECK HARNESS BETWEEN ECM AND TCM. 1) Turn the ignition switch to OFF. 2) Disconnect the connector from ECM. 3) Disconnect the connector from TCM. 4) Measure the resistance between connectors of ECM and TCM. <i>Connector & terminal</i> (B137) No. 18 — (B55) No. 3: (B137) No. 26 — (B54) No. 12:	Is the resistance less than 1 Ω ?	Go to step 2.	Repair the harness connector.
2	CHECK HARNESS BETWEEN ECM AND TCM. Measure the resistance between ECM connector and chassis ground. <i>Connector & terminal</i> (B137) No. 18 — Chassis ground: (B137) No. 26 — Chassis ground:	Is the resistance more than 1 M Ω ?	Go to step 3.	Repair the harness connector.
3	CHECK HARNESS BETWEEN ECM AND TCM. Measure the resistance of ECM connectors. <i>Connector & terminal</i> (B137) No. 18 — (B137) No. 26:	Is the resistance more than 1 M Ω ?	Go to step 4.	Repair the harness connector.
4	CHECK AT SYSTEM STATUS. Check the AT using Subaru Select Monitor.	Does the Subaru Select Monitor display DTC P1718?	Inspect the AT system.	Replace the ECM. <Ref. to FU(H4DOTC)-42, Engine Control Module (ECM).>

BY:DTC P0604 — INTERNAL CONTROL MODULE RANDOM ACCESS MEMORY (RAM) ERROR —

DTC DETECTING CONDITION:

- Immediately at fault recognition
- GENERAL DESCRIPTION <Ref. to GD(H4DOTC)-182, DTC P0604 — INTERNAL CONTROL MODULE RANDOM ACCESS MEMORY (RAM) ERROR —, Diagnostic Trouble Code (DTC) Detecting Criteria.>

TROUBLE SYMPTOM:

- Engine does not start.
- Engine stalls.

CAUTION:

After repair or replacement of faulty parts, conduct Clear Memory Mode <Ref. to EN(H4DOTC)-44, OPERATION, Clear Memory Mode.> and Inspection Mode <Ref. to EN(H4DOTC)-36, OPERATION, Inspection Mode.>.

DIAGNOSTIC PROCEDURE WITH DIAGNOSTIC TROUBLE CODE (DTC) ENGINE (DIAGNOSTICS)

WIRING DIAGRAM:

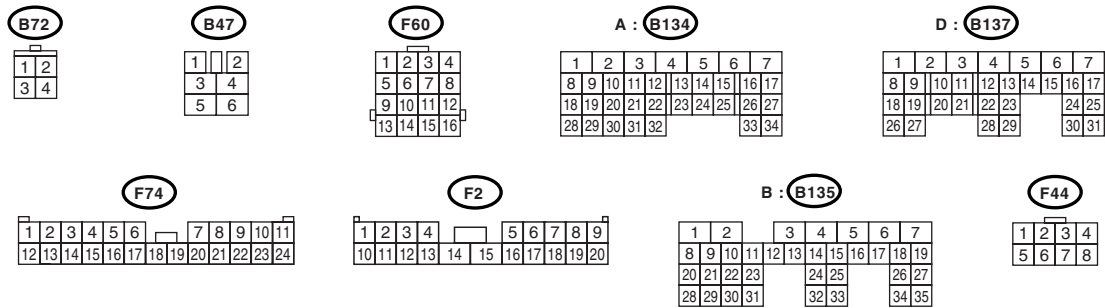
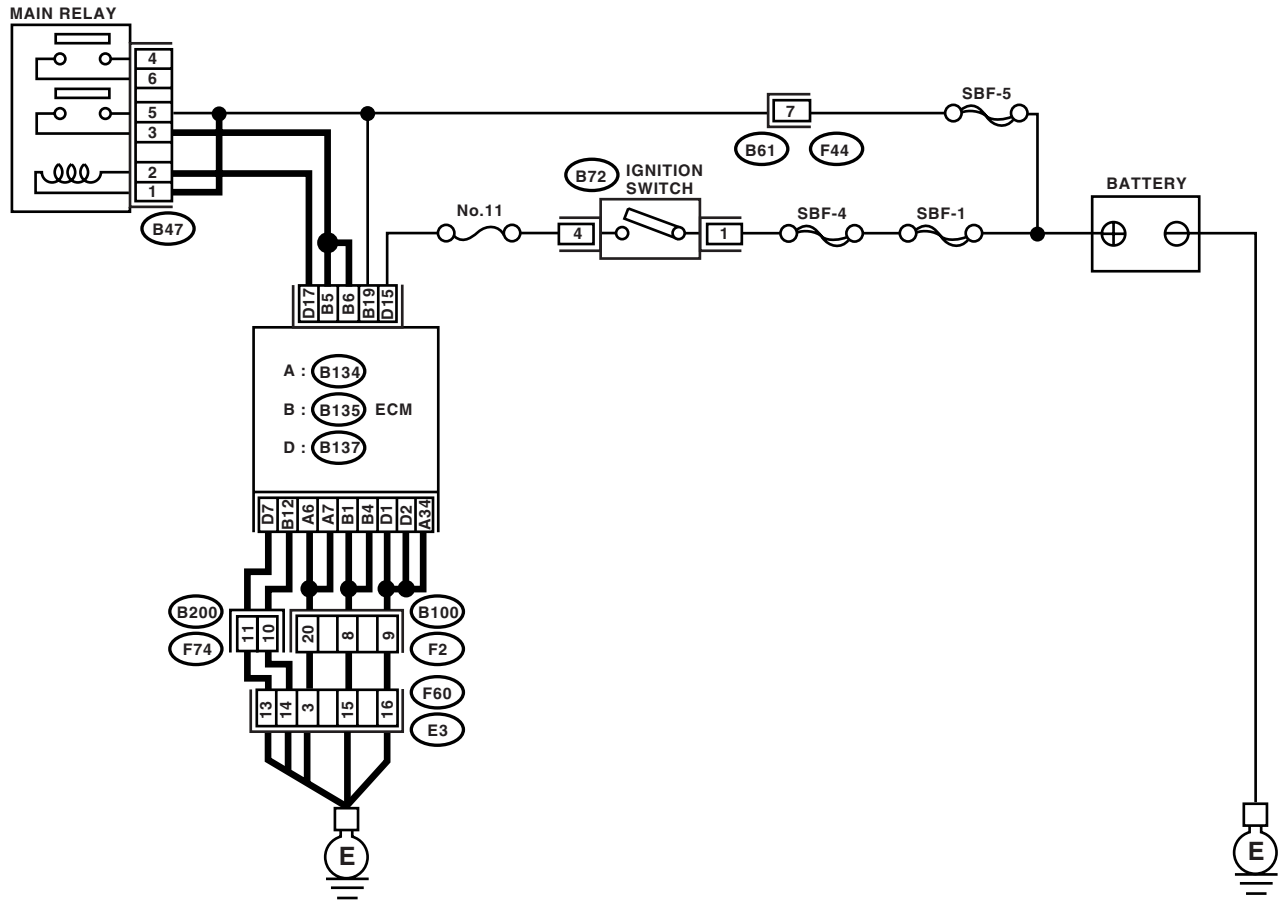

EN-02016

Step	Check	Yes	No
1	CHECK ANY OTHER DTC ON DISPLAY. Does the Subaru Select Monitor or OBD-II general scan tool indicate DTC P0604?	Replace the ECM. <Ref. to FU(H4DOTC)-42, Engine Control Module (ECM).>	A temporary poor contact.

**BZ:DTC P0605 — INTERNAL CONTROL MODULE READ ONLY MEMORY (ROM)
ERROR —**

NOTE:

For the diagnostic procedure, refer to DTC P0607. <Ref. to EN(H4DOTC)-260, DTC P0607 — CONTROL MODULE PERFORMANCE —, Diagnostic Procedure with Diagnostic Trouble Code (DTC).>

DIAGNOSTIC PROCEDURE WITH DIAGNOSTIC TROUBLE CODE (DTC)

ENGINE (DIAGNOSTICS)

CA:DTC P0607 — CONTROL MODULE PERFORMANCE —

DTC DETECTING CONDITION:

- Immediately at fault recognition
- GENERAL DESCRIPTION <Ref. to GD(H4DOTC)-183, DTC P0605 — INTERNAL CONTROL MODULE READ ONLY MEMORY (ROM) ERROR —, Diagnostic Trouble Code (DTC) Detecting Criteria.> <Ref. to GD(H4DOTC)-184, DTC P0607 — CONTROL MODULE PERFORMANCE —, Diagnostic Trouble Code (DTC) Detecting Criteria.>

TROUBLE SYMPTOM:

- Erroneous idling
- Poor driving performance

CAUTION:

After repair or replacement of faulty parts, conduct Clear Memory Mode <Ref. to EN(H4DOTC)-44, OPERATION, Clear Memory Mode.> and Inspection Mode <Ref. to EN(H4DOTC)-36, OPERATION, Inspection Mode.>.

DIAGNOSTIC PROCEDURE WITH DIAGNOSTIC TROUBLE CODE (DTC)

ENGINE (DIAGNOSTICS)

WIRING DIAGRAM:

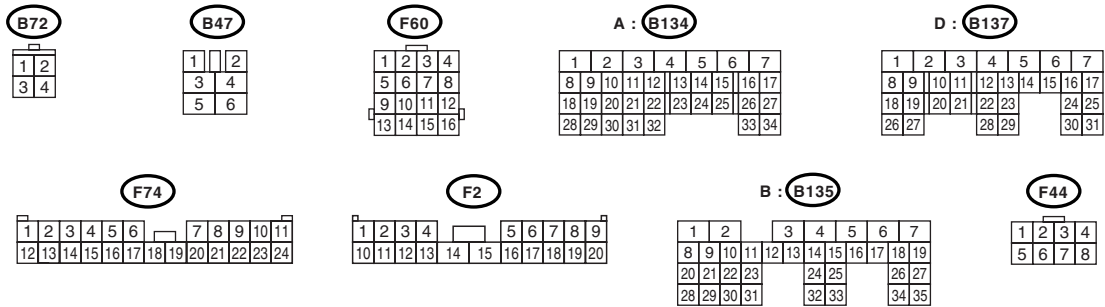
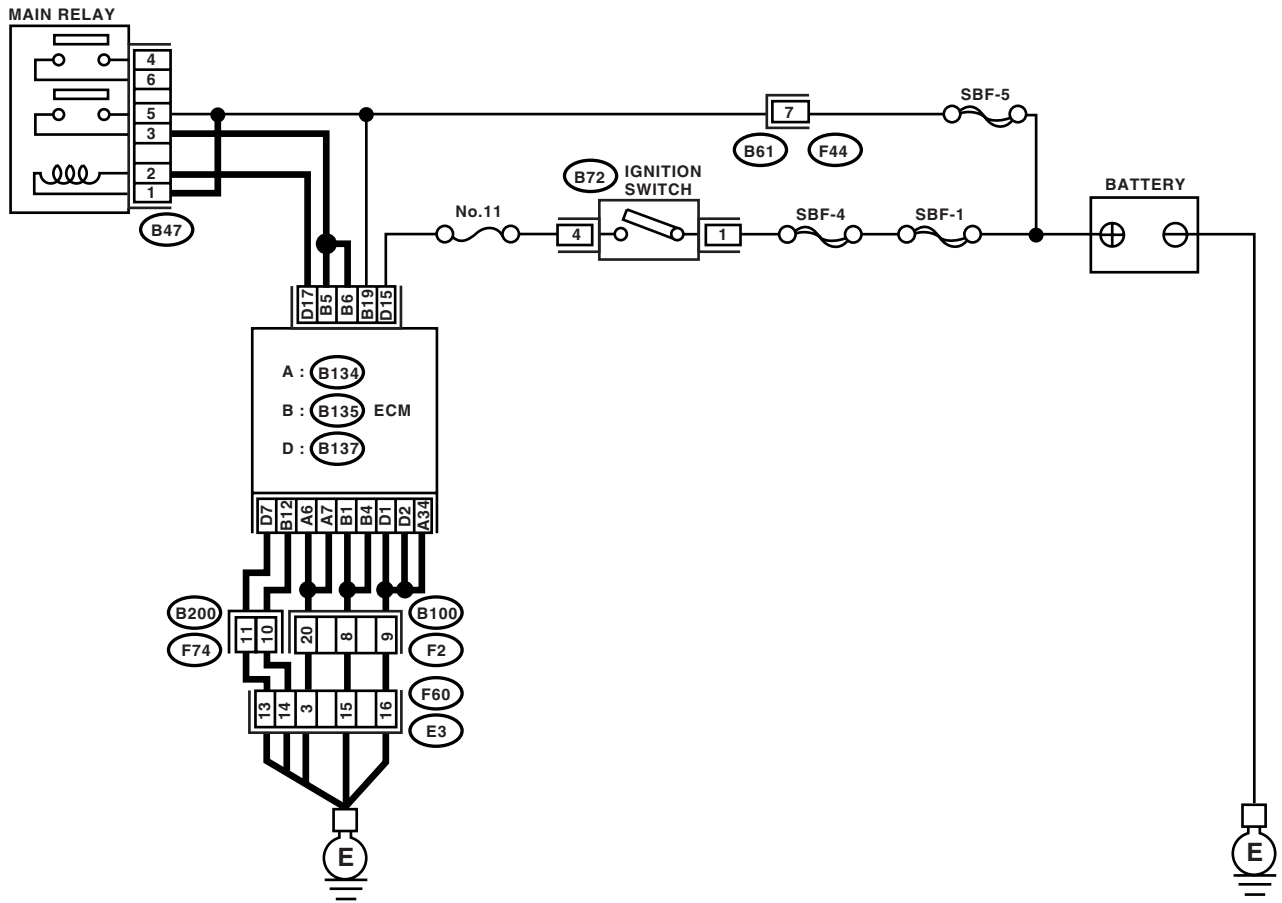

EN-02016

DIAGNOSTIC PROCEDURE WITH DIAGNOSTIC TROUBLE CODE (DTC)

ENGINE (DIAGNOSTICS)

Step	Check	Yes	No
1 CHECK INPUT VOLTAGE OF ECM. 1) Turn the ignition switch to ON. 2) Measure the voltage between ECM connector and ground. Connector & terminal (B135) No. 5 (+) — Chassis ground (-): (B135) No. 6 (+) — Chassis ground (-):	Is the voltage 10 — 13 V?	Go to step 2.	Repair the open circuit or ground short of power supply circuit.
2 CHECK INPUT VOLTAGE OF ECM. 1) Start the engine. 2) Measure the voltage between ECM connector and ground. Connector & terminal (B135) No. 5 (+) — Chassis ground (-): (B135) No. 6 (+) — Chassis ground (-):	Is the voltage 13 — 15 V?	Go to step 3.	Repair the open circuit or ground short of power supply circuit.
3 CHECK GROUND HARNESS OF ECM. Measure the voltage between ECM connector and ground. Connector & terminal (B137) No. 1 (+) — Chassis ground (-): (B137) No. 2 (+) — Chassis ground (-):	Is the voltage less than 1 V?	Repair poor contact of ECM connector. If poor contact occur, replace the ECM.	Retighten the engine ground terminal.

**CB:DTC P0638 — THROTTLE ACTUATOR CONTROL RANGE/PERFORMANCE
(BANK 1) —**

NOTE:

For the diagnostic procedure, refer to DTC P2101. <Ref. to EN(H4DOTC)-348, DTC P2101 — THROTTLE ACTUATOR CONTROL MOTOR CIRCUIT RANGE/PERFORMANCE —, Diagnostic Procedure with Diagnostic Trouble Code (DTC).>

DIAGNOSTIC PROCEDURE WITH DIAGNOSTIC TROUBLE CODE (DTC)

ENGINE (DIAGNOSTICS)

CC:DTC P0691 — COOLING FAN 1 CONTROL CIRCUIT LOW —

DTC DETECTING CONDITION:

- Two consecutive driving cycles with fault
- GENERAL DESCRIPTION <Ref. to GD(H4DOTC)-190, DTC P0691 — COOLING FAN 1 CONTROL CIRCUIT LOW —, Diagnostic Trouble Code (DTC) Detecting Criteria.>

TROUBLE SYMPTOM:

- Radiator fan does not operate properly.
- Overheating

CAUTION:

After repair or replacement of faulty parts, conduct Clear Memory Mode <Ref. to EN(H4DOTC)-44, OPERATION, Clear Memory Mode.> and Inspection Mode <Ref. to EN(H4DOTC)-36, OPERATION, Inspection Mode.>.

DIAGNOSTIC PROCEDURE WITH DIAGNOSTIC TROUBLE CODE (DTC)

ENGINE (DIAGNOSTICS)

WIRING DIAGRAM:

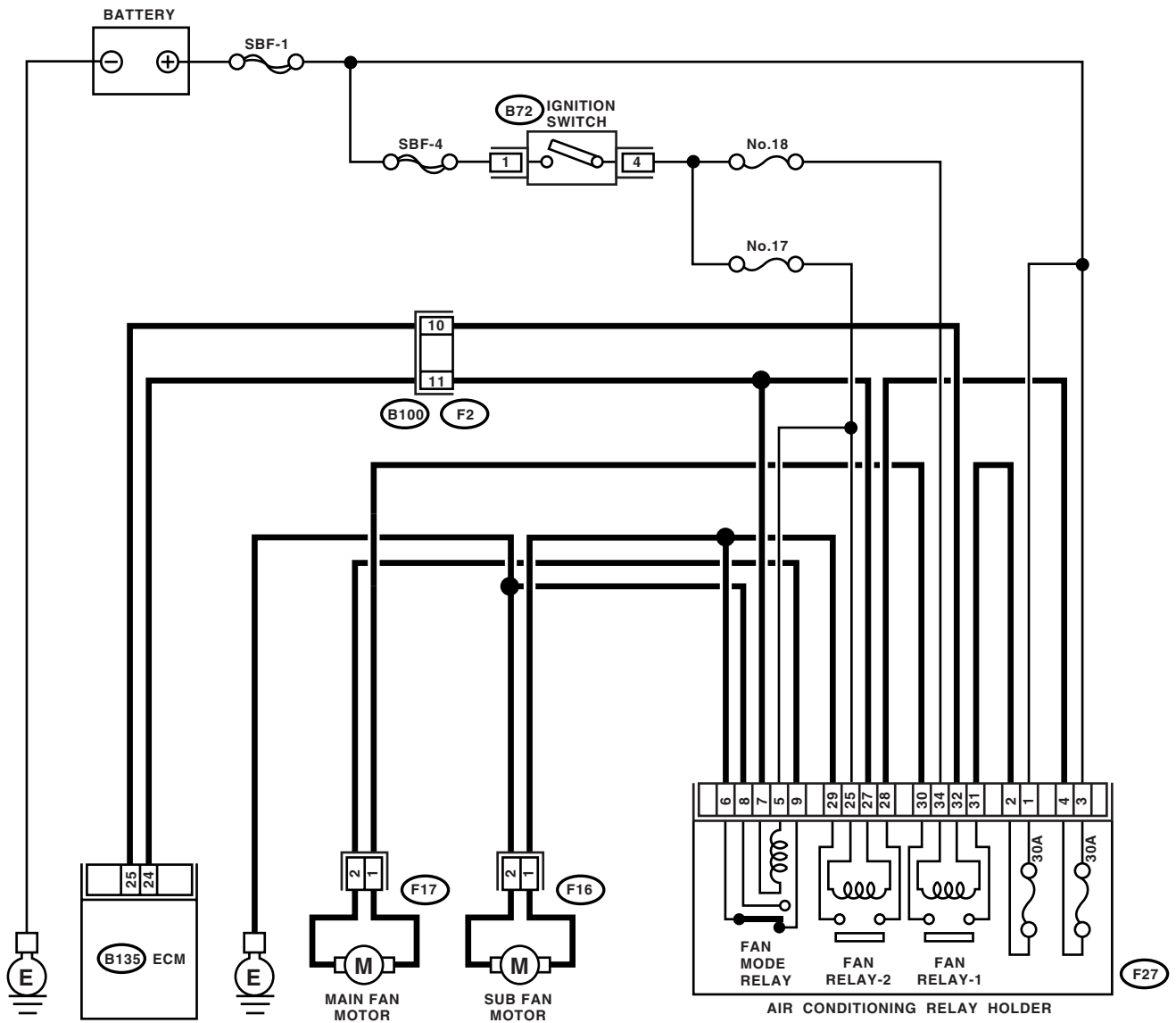

F16

F17



B72



B135

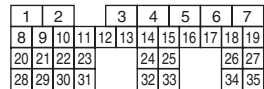

F2

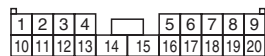

F27

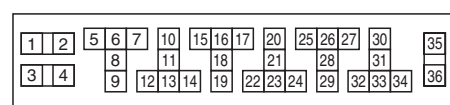

EN-02036

DIAGNOSTIC PROCEDURE WITH DIAGNOSTIC TROUBLE CODE (DTC)

ENGINE (DIAGNOSTICS)

Step	Check	Yes	No
1 CHECK OUTPUT SIGNAL FROM ECM. 1) Turn the ignition switch to OFF. 2) Connect the test mode connector. 3) Turn the ignition switch to ON. 4) While operating the radiator fan relay, measure voltage between ECM terminal and ground. NOTE: Radiator fan relay operation can be executed using Subaru Select Monitor. For procedure, refer to "Compulsory Valve Operation Check Mode". <Ref. to EN(H4DOTC)-29, Subaru Select Monitor.> Connector & terminal (B135) No. 25 (+) — Chassis ground (-): (B135) No. 24 (+) — Chassis ground (-):	Does the voltage change 0 — 10 V?	Repair poor contact in ECM connector.	Go to step 2.
2 CHECK GROUND SHORT CIRCUIT IN RADIATOR FAN RELAY CONTROL CIRCUIT. 1) Turn the ignition switch to OFF. 2) Disconnect the connectors from ECM. 3) Measure the resistance of harness between ECM connector and chassis ground. Connector & terminal (B135) No. 25 — Chassis ground: (B135) No. 24 — Chassis ground:	Is the resistance more than 1 M Ω ?	Go to step 3.	Repair ground short circuit in radiator fan relay control circuit.
3 CHECK POWER SUPPLY FOR RELAY. 1) Remove the fan relay 1 and fan relay 2 from A/C relay holder. 2) Turn the ignition switch to ON. 3) Measure the voltage between fuse and relay box (F/B) connector and chassis ground. Connector & terminal (F27) No. 27 (+) — Chassis ground (-): (F27) No. 32 (+) — Chassis ground (-):	Is the voltage more than 10 V?	Go to step 4.	Repair open circuit in harness between ignition switch and fuse and relay box (F/B) connector.
4 CHECK FAN RELAY. 1) Turn the ignition switch to OFF. 2) Measure the resistance between main fan relay terminals. Terminals No. 32 — No. 34: (Fan relay 1) No. 25 — No. 27: (Fan relay 2)	Is the resistance 87 — 107 Ω ?	Go to step 5.	Replace the fan relay.
5 CHECK OPEN CIRCUIT IN MAIN FAN RELAY CONTROL CIRCUIT. Measure the resistance of harness between ECM and fan relay connector. Connector & terminal (B135) No. 25 — (F27) No. 32: (B135) No. 24 — (F27) No. 27:	Is the resistance less than 1 Ω ?	Go to step 6.	Repair harness and connector. NOTE: In this case, repair the following: • Open circuit in harness between ECM and fan relay connector • Poor contact in coupling connector
6 CHECK POOR CONTACT. Check poor contact in ECM or fan relay connector.	Is there poor contact in ECM or fan relay connector?	Repair poor contact in ECM or fan relay connector.	Contact your SOA Service Center.

CD:DTC P0692 — COOLING FAN 1 CONTROL CIRCUIT HIGH —

DTC DETECTING CONDITION:

- Two consecutive driving cycles with fault
- GENERAL DESCRIPTION <Ref. to GD(H4DOTC)-191, DTC P0692 — COOLING FAN 1 CONTROL CIRCUIT HIGH —, Diagnostic Trouble Code (DTC) Detecting Criteria.>

TROUBLE SYMPTOM:

- Radiator fan does not operate properly.
- Overheating

CAUTION:

After repair or replacement of faulty parts, conduct Clear Memory Mode <Ref. to EN(H4DOTC)-44, OPERATION, Clear Memory Mode.> and Inspection Mode <Ref. to EN(H4DOTC)-36, OPERATION, Inspection Mode.>.

DIAGNOSTIC PROCEDURE WITH DIAGNOSTIC TROUBLE CODE (DTC) ENGINE (DIAGNOSTICS)

WIRING DIAGRAM:

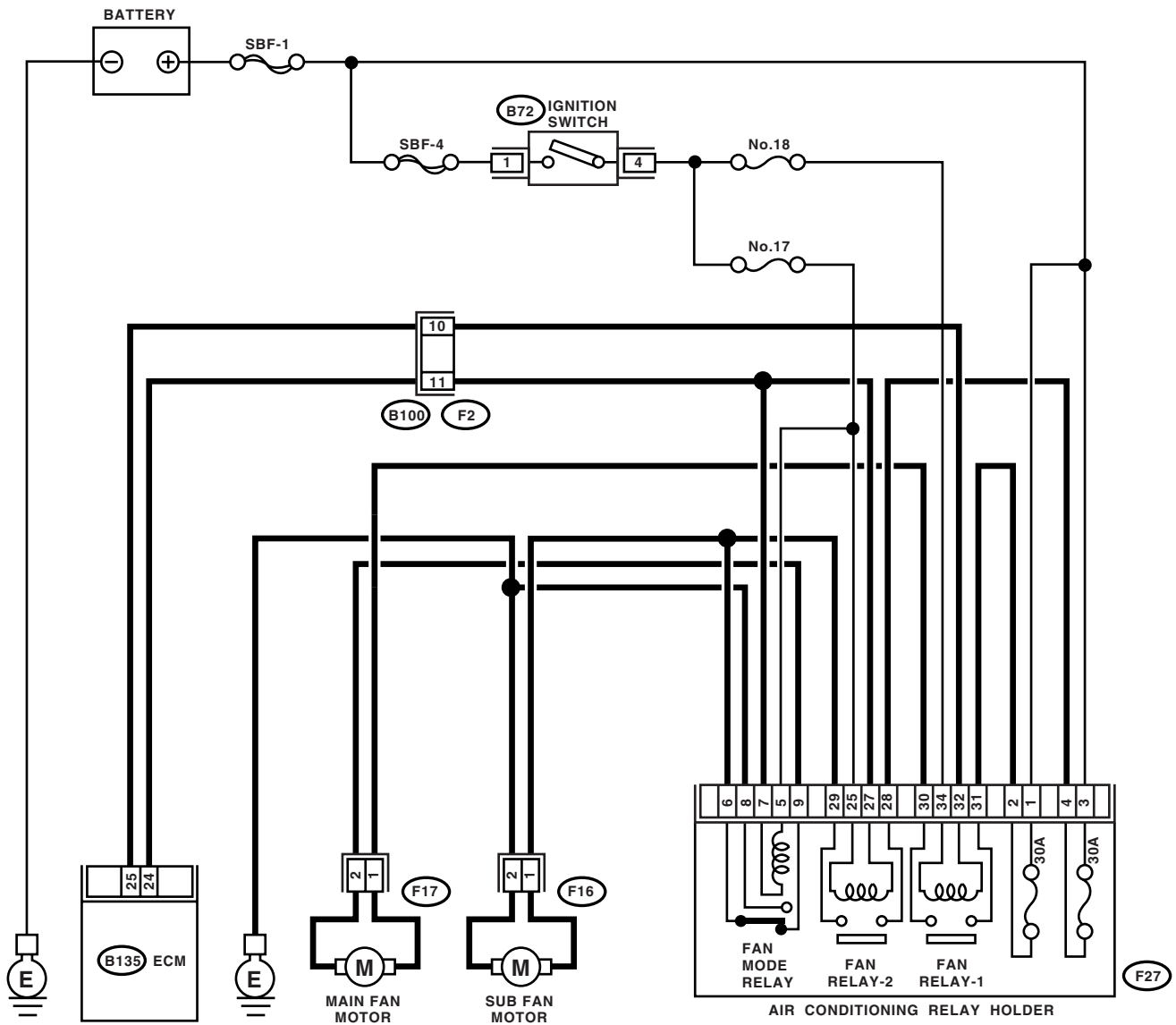

(F16)

(F17)

1	2
---	---

(B72)

1	2
3	4

1	2
---	---

(B135)

1	2	3	4	5	6	7					
8	9	10	11	12	13	14	15	16	17	18	19
20	21	22	23	24	25	26	27				
28	29	30	31	32	33	34	35				

(F2)

1	2	3	4	5	6	7	8	9		
10	11	12	13	14	15	16	17	18	19	20

(F27)

1	2	5	6	7	10	15	16	17	20	25	26	27	30	35
3	4	8	11	18	21	28	31							
9	12	13	14	19	22	23	24	29	32	33	34	36		

EN-02036

DIAGNOSTIC PROCEDURE WITH DIAGNOSTIC TROUBLE CODE (DTC)

ENGINE (DIAGNOSTICS)

Step	Check	Yes	No
<p>1 CHECK OUTPUT SIGNAL FROM ECM.</p> <p>1) Turn the ignition switch to OFF. 2) Connect the test mode connector. 3) Turn the ignition switch to ON. 4) While operating the radiator fan relay, measure the voltage between ECM and chassis ground.</p> <p>NOTE: Radiator fan relay operation can be executed using the Subaru Select Monitor. For procedure, refer to "Compulsory Valve Operation Check Mode". <Ref. to EN(H4DOTC)-45, Compulsory Valve Operation Check Mode.></p> <p>Connector & terminal (B135) No. 25 (+) — Chassis ground (-): (B135) No. 24 (+) — Chassis ground (-):</p>	<p>Does the voltage change 0 — 10 V?</p>	<p>Even if malfunction indicator light lights up, the circuit has returned to a normal condition at this time. In this case, repair the poor contact in ECM connector.</p>	<p>Go to step 2.</p>
<p>2 CHECK SHORT CIRCUIT IN RADIATOR FAN RELAY CONTROL CIRCUIT.</p> <p>1) Turn the ignition switch to OFF. 2) Remove the fan relay 1, fan relay 2 and fan mode relay. 3) Disconnect the test mode connector. 4) Turn the ignition switch to ON. 5) Measure the voltage between ECM and chassis ground.</p> <p>Connector & terminal (B135) No. 25 (+) — Chassis ground (-): (B135) No. 24 (+) — Chassis ground (-):</p>	<p>Is the voltage more than 10 V?</p>	<p>Repair the battery short circuit in radiator fan relay control circuit. After repair, replace the ECM. <Ref. to FU(H4DOTC)-42, Engine Control Module (ECM).></p>	<p>Go to step 3.</p>
<p>3 CHECK FAN RELAY.</p> <p>1) Turn the ignition switch to OFF. 2) Remove the fan relay. 3) Measure the resistance between fan relay terminals.</p> <p>Terminals No. 30 — No. 31: (Fan relay 1) No. 28 — No. 29: (Fan relay 2)</p>	<p>Is the resistance less than 1 Ω?</p>	<p>Replace the fan relay and ECM. <Ref. to FU(H4DOTC)-42, Engine Control Module (ECM).></p>	<p>Go to step 4.</p>
<p>4 CHECK FAN MODE RELAY.</p> <p>1) Remove the fan mode relay. 2) Measure the resistance between fan mode relay terminals.</p> <p>Terminals No. 8 — No. 9: (Fan mode relay)</p>	<p>Is the resistance less than 1 Ω?</p>	<p>Replace the fan mode relay and ECM. <Ref. to FU(H4DOTC)-42, Engine Control Module (ECM).></p>	<p>Go to step 5.</p>
<p>5 CHECK POOR CONTACT.</p> <p>Check poor contact in ECM connector.</p>	<p>Is there poor contact in ECM connector?</p>	<p>Repair the poor contact in ECM connector.</p>	<p>Replace the ECM. <Ref. to FU(H4DOTC)-42, Engine Control Module (ECM).></p>

DIAGNOSTIC PROCEDURE WITH DIAGNOSTIC TROUBLE CODE (DTC)

ENGINE (DIAGNOSTICS)

CE:DTC P0700 — REQUEST AT MIL ON —

GENERAL DESCRIPTION <Ref. to GD(H4DOTC)-192, DTC P0700 — REQUEST AT MIL ON —, Diagnostic Trouble Code (DTC) Detecting Criteria.>

NOTE:

Refer to AT-section for diagnostic procedure. <Ref. to 4AT(H4SO)-2, PROCEDURE, Basic Diagnostic Procedure.>

CF:DTC P0851 — NEUTRAL SWITCH INPUT CIRCUIT LOW —

DTC DETECTING CONDITION:

- Two consecutive driving cycles with fault
- GENERAL DESCRIPTION <Ref. to GD(H4DOTC)-194, DTC P0851 — NEUTRAL SWITCH INPUT CIRCUIT LOW (MT MODEL) —, Diagnostic Trouble Code (DTC) Detecting Criteria.>

TROUBLE SYMPTOM:

Erroneous idling

CAUTION:

After repair or replacement of faulty parts, conduct Clear Memory Mode <Ref. to EN(H4DOTC)-44, OPERATION, Clear Memory Mode.> and Inspection Mode <Ref. to EN(H4DOTC)-36, OPERATION, Inspection Mode.>.

WIRING DIAGRAM:

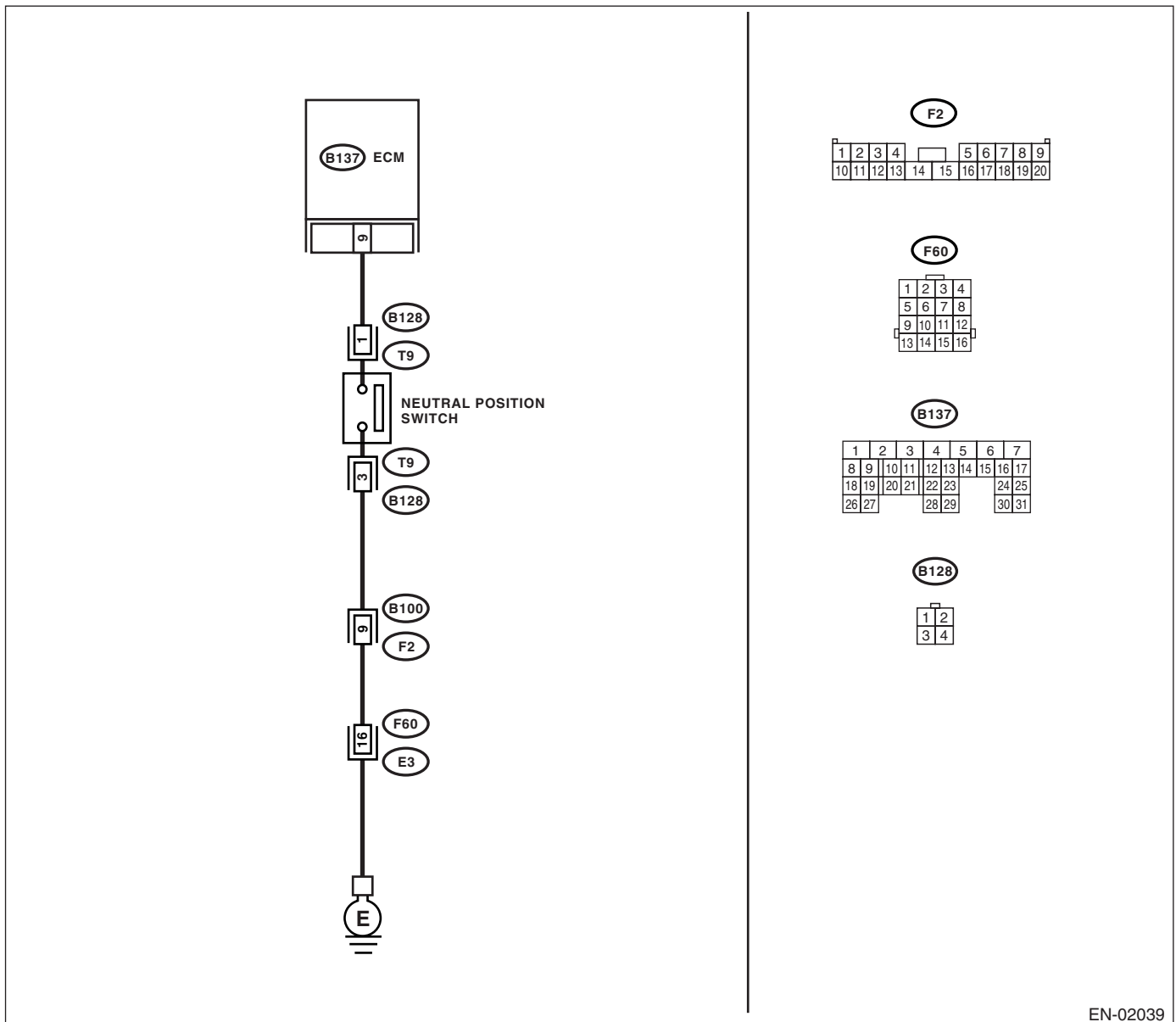

EN-02039

DIAGNOSTIC PROCEDURE WITH DIAGNOSTIC TROUBLE CODE (DTC)

ENGINE (DIAGNOSTICS)

Step	Check	Yes	No
1 CHECK INPUT SIGNAL FOR ECM. 1) Turn the ignition switch to ON. 2) Place the shift lever in neutral. 3) Measure the voltage between ECM and chassis ground. <i>Connector & terminal</i> <i>(B137) No. 9 (+) — Chassis ground (-):</i>	Is the voltage more than 10 V?	Go to step 2.	Go to step 4.
2 CHECK INPUT SIGNAL FOR ECM. 1) Place the shift lever in a position except for neutral. 2) Measure the voltage between ECM and chassis ground. <i>Connector & terminal</i> <i>(B137) No. 9 (+) — Chassis ground (-):</i>	Is the voltage less than 1 V?	Go to step 3.	Go to step 4.
3 CHECK POOR CONTACT. Check poor contact in ECM connector.	Is there poor contact in ECM connector?	Repair poor contact in ECM connector.	Contact your SOA Service Center.
4 CHECK NEUTRAL POSITION SWITCH. 1) Turn the ignition switch to OFF. 2) Disconnect the connector from transmission harness. 3) Place the shift lever in neutral. 4) Measure the resistance between transmission harness and connector terminals. <i>Connector & terminal</i> <i>(T9) No. 1 — No. 3:</i>	Is the resistance more than 1 M Ω ?	Go to step 5.	Repair short circuit in transmission harness or replace neutral position switch.
5 CHECK NEUTRAL POSITION SWITCH. 1) Place the shift lever in a position except for neutral. 2) Measure the resistance between transmission harness connector terminals.	Is the resistance less than 1 Ω ?	Go to step 6.	Repair short circuit in transmission harness or replace neutral position switch.
6 CHECK HARNESS BETWEEN ECM AND NEUTRAL POSITION SWITCH CONNECTOR. Measure the resistance between ECM and chassis ground. <i>Connector & terminal</i> <i>(B137) No. 9 — Chassis ground:</i>	Is the resistance more than 1 M Ω ?	Go to step 7.	Repair ground short circuit in harness between ECM and transmission harness connector.
7 CHECK HARNESS BETWEEN ECM AND NEUTRAL POSITION SWITCH CONNECTOR. 1) Disconnect the connector from ECM. 2) Measure the resistance of harness between ECM and transmission harness connector. <i>Connector & terminal</i> <i>(B137) No. 9 — (B128) No. 1:</i>	Is the resistance less than 1 Ω ?	Go to step 8.	Repair open circuit in harness between ECM and transmission harness connector.
8 CHECK HARNESS BETWEEN ECM AND NEUTRAL POSITION SWITCH CONNECTOR. Measure the resistance of harness between transmission harness connector and engine ground. <i>Connector & terminal</i> <i>(B128) No. 1 — Engine ground:</i>	Is the resistance less than 5 Ω ?	Go to step 9.	Repair open circuit between transmission harness connector and engine ground terminal.
9 CHECK POOR CONTACT. Check poor contact in transmission harness connector.	Is there poor contact in transmission harness connector?	Repair poor contact in transmission harness connector.	Contact your SOA Service Center.

CG:DTC P0852 — NEUTRAL SWITCH INPUT CIRCUIT HIGH —

DTC DETECTING CONDITION:

- Two consecutive driving cycles with fault
- GENERAL DESCRIPTION <Ref. to GD(H4DOTC)-195, DTC P0852 — NEUTRAL SWITCH INPUT CIRCUIT HIGH (AT MODEL) —, Diagnostic Trouble Code (DTC) Detecting Criteria.>

TROUBLE SYMPTOM:

Erroneous idling

CAUTION:

After repair or replacement of faulty parts, conduct Clear Memory Mode <Ref. to EN(H4DOTC)-44, OPERATION, Clear Memory Mode.> and Inspection Mode <Ref. to EN(H4DOTC)-36, OPERATION, Inspection Mode.>.

WIRING DIAGRAM:

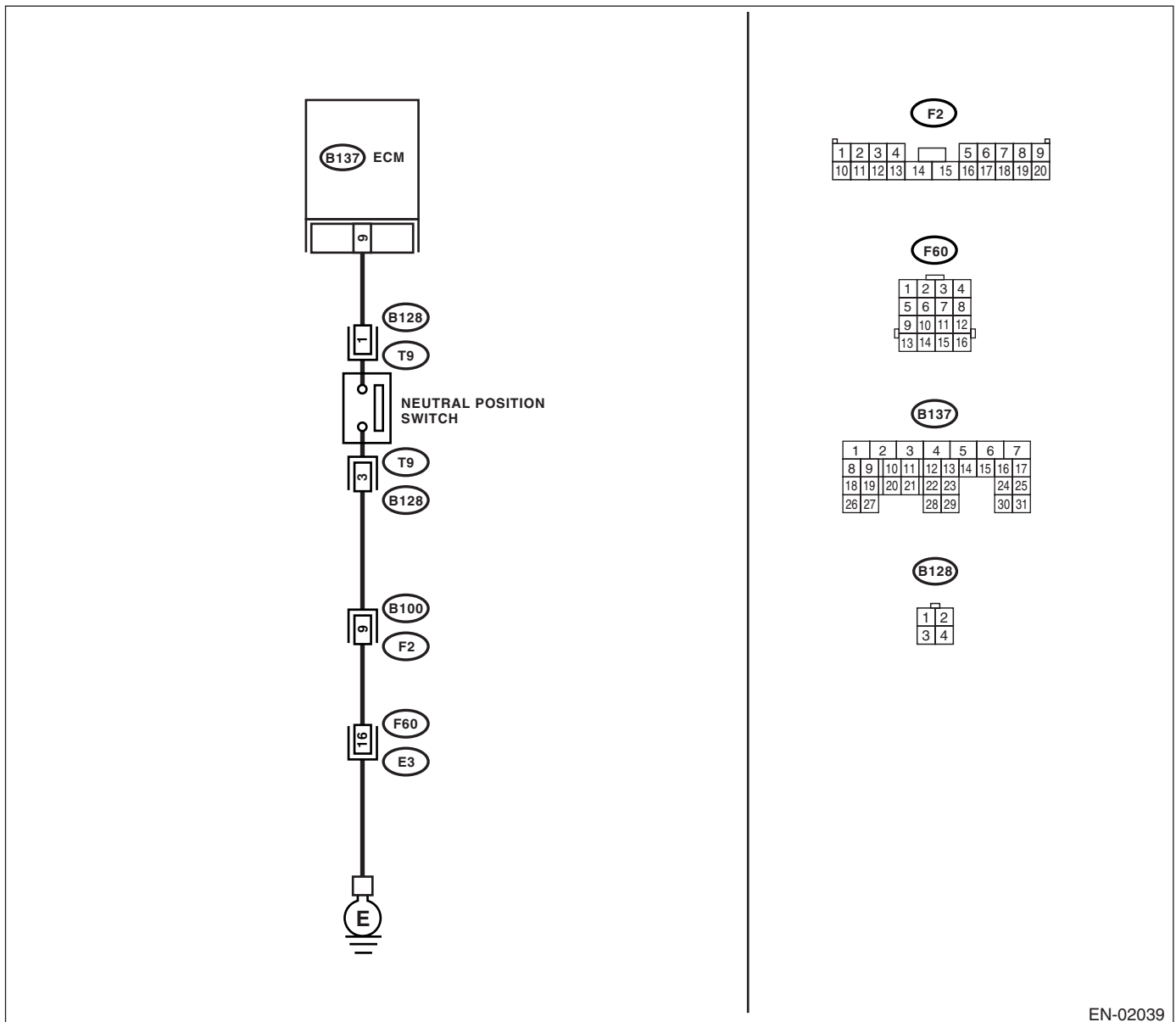

EN-02039

DIAGNOSTIC PROCEDURE WITH DIAGNOSTIC TROUBLE CODE (DTC)

ENGINE (DIAGNOSTICS)

Step	Check	Yes	No
1 CHECK INPUT SIGNAL FOR ECM. 1) Turn the ignition switch to ON. 2) Set the shift lever to except neutral position. 3) Measure the voltage between ECM and chassis ground. Connector & terminal (B137) No. 9 (+) — Chassis ground (-):	Is the voltage less than 1 V?	Go to step 2.	Go to step 4.
2 CHECK INPUT SIGNAL FOR ECM. 1) Set the shift lever to neutral position. 2) Measure the voltage between ECM and chassis ground. Connector & terminal (B137) No. 9 (+) — Chassis ground (-):	Is the voltage more than 10 V?	Go to step 3.	Go to step 4.
3 CHECK POOR CONTACT. Check poor contact in ECM connector.	Is there poor contact in ECM connector?	Repair the poor contact in ECM connector.	Contact your SOA Service Center.
4 CHECK INPUT SIGNAL FOR ECM. 1) Disconnect ECM connector from ECM. 2) Measure the voltage between ECM and chassis ground. Connector & terminal (B137) No. 9 (+) — Chassis ground (-):	Is the voltage more than 10 V?	Repair the battery short circuit in harness between ECM and transmission connector.	Go to step 5.
5 CHECK HARNESS BETWEEN ECM AND TRANSMISSION HARNESS CONNECTOR. 1) Turn the ignition switch to OFF. 2) Disconnect the connectors from ECM and transmission harness connector (T9). 3) Measure the resistance of harness between ECM and neutral switch connector. Connector & terminal (B137) No. 9 — (B128) No. 1:	Is the resistance less than 1 Ω ?	Go to step 6.	Repair the harness and connector. NOTE: In this case, repair the following: <ul style="list-style-type: none"> • Open circuit in harness between ECM and transmission harness • Poor contact in transmission harness connector • Poor contact in ECM connector
6 CHECK NEUTRAL POSITION SWITCH GROUND LINE. Measure the resistance of harness between transmission harness connector and engine ground. Connector & terminal (B128) No. 3 — Engine ground:	Is the resistance less than 5 Ω ?	Go to step 7.	Repair the open circuit in harness of neutral position switch ground line.
7 CHECK NEUTRAL POSITION SWITCH. 1) Set the shift lever to except neutral position. 2) Measure the resistance between transmission harness connector receptacle's terminals. Terminals No. 1 — No. 3:	Is the resistance less than 1 Ω ?	Go to step 8.	Replace the neutral position switch.
8 CHECK POOR CONTACT. Check poor contact in the transmission harness connector.	Is there poor contact in the transmission harness connector?	Repair poor contact in transmission harness connector.	Contact your SOA Service Center.

CH: DTC P1086 — TUMBLE GENERATED VALVE POSITION SENSOR 2 CIRCUIT LOW —

DTC DETECTING CONDITION:

- Immediately at fault recognition
- GENERAL DESCRIPTION <Ref. to GD(H4DOTC)-197, DTC P1086 — TUMBLE GENERATED VALVE POSITION SENSOR 2 CIRCUIT LOW —, Diagnostic Trouble Code (DTC) Detecting Criteria.>

TROUBLE SYMPTOM:

- Erroneous idling
- Engine stalls.
- Poor driving performance

CAUTION:

After repair or replacement of faulty parts, conduct Clear Memory Mode <Ref. to EN(H4DOTC)-44, OPERATION, Clear Memory Mode.> and Inspection Mode <Ref. to EN(H4DOTC)-36, OPERATION, Inspection Mode.>.

WIRING DIAGRAM:

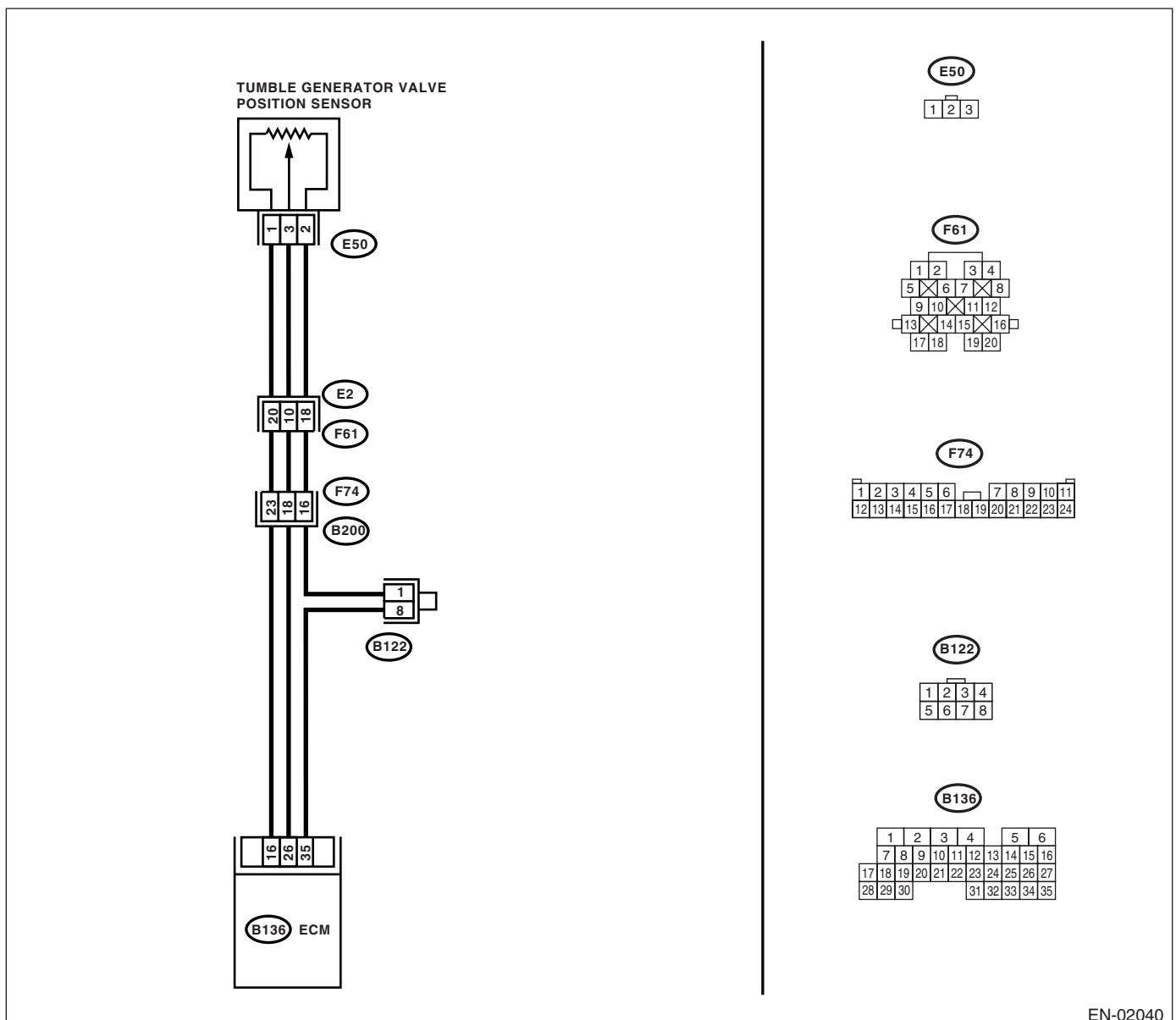

EN-02040

DIAGNOSTIC PROCEDURE WITH DIAGNOSTIC TROUBLE CODE (DTC)

ENGINE (DIAGNOSTICS)

Step	Check	Yes	No
1 CHECK CURRENT DATA. 1) Start the engine. 2) Read the data of throttle position sensor signal using Subaru Select Monitor or OBD-II general scan tool. NOTE: <ul style="list-style-type: none"> Subaru Select Monitor For detailed operation procedure, refer to the "READ CURRENT DATA FOR ENGINE". <Ref. to EN(H4DOTC)-29, Subaru Select Monitor.> <ul style="list-style-type: none"> OBD-II general scan tool For detailed operation procedures, refer to the OBD-II General Scan Tool Instruction Manual.	Is the voltage less than 0.1 V?	Go to step 2.	Even if malfunction indicator light lights up, the circuit has returned to a normal condition at this time. A temporary poor contact of the connector may be the cause. NOTE: In this case, repair the following: <ul style="list-style-type: none"> Poor contact in throttle position sensor connector Poor contact in ECM connector Poor contact in coupling connector
2 CHECK INPUT SIGNAL FOR ECM. Measure the voltage between ECM connector and chassis ground while tumble generator valve is fully closed. Connector & terminal (B136) No. 16 (+) — Chassis ground (-):	Is the voltage more than 4.5 V?	Go to step 4.	Go to step 3.
3 CHECK INPUT SIGNAL FOR ECM. Measure the voltage between ECM connector and chassis ground. Connector & terminal (B136) No. 16 (+) — Chassis ground (-):	Shake the ECM harness and connector, while monitoring value of voltage meter. Does the voltage change?	Repair the poor contact in ECM connector.	Contact your SOA Service Center. NOTE: Inspection by DTM is required, because probable cause is deterioration of multiple parts.
4 CHECK INPUT SIGNAL FOR ECM. Measure the voltage between ECM connector and chassis ground. Connector & terminal (B136) No. 26 (+) — Chassis ground (-):	Is the voltage less than 0.1 V?	Go to step 6.	Go to step 5.
5 CHECK INPUT SIGNAL FOR ECM. (USING SUBARU SELECT MONITOR) Measure the voltage between ECM connector and chassis ground.	Shake the ECM harness and connector, while monitoring value of Subaru Select Monitor. Does the voltage change?	Repair the poor contact in ECM connector.	Go to step 6.

DIAGNOSTIC PROCEDURE WITH DIAGNOSTIC TROUBLE CODE (DTC)

ENGINE (DIAGNOSTICS)

Step	Check	Yes	No
<p>6</p> <p>CHECK HARNESS BETWEEN ECM AND TUMBLE GENERATOR VALVE POSITION SENSOR CONNECTOR.</p> <p>1) Turn the ignition switch to OFF. 2) Disconnect the connectors from tumble generator valve position sensor. 3) Turn the ignition switch to ON. 4) Measure the voltage between tumble generator valve position sensor connector and engine ground.</p> <p>Connector & terminal (E50) No. 1 (+) — Engine ground (-):</p>	<p>Is the voltage more than 4.5 V?</p>	<p>Go to step 7.</p>	<p>Repair the harness and connector.</p> <p>NOTE: In this case, repair the following:</p> <ul style="list-style-type: none"> • Open circuit in harness between tumble generator valve position sensor and ECM connector • Poor contact in tumble generator valve position sensor connector • Poor contact in ECM connector • Poor contact in coupling connector • Poor contact in joint connector
<p>7</p> <p>CHECK HARNESS BETWEEN ECM AND TUMBLE GENERATOR VALVE POSITION SENSOR CONNECTOR.</p> <p>1) Turn the ignition switch to OFF. 2) Measure the resistance of harness between ECM connector and tumble generator valve position sensor connector.</p> <p>Connector & terminal (B136) No. 26 — (E50) No. 3:</p>	<p>Is the resistance less than 1 Ω?</p>	<p>Go to step 8.</p>	<p>Repair the harness and connector.</p> <p>NOTE: In this case, repair the following:</p> <ul style="list-style-type: none"> • Open circuit in harness between tumble generator valve position sensor and ECM connector • Poor contact in ECM connector • Poor contact in tumble generator valve position sensor connector • Poor contact in coupling connector
<p>8</p> <p>CHECK HARNESS BETWEEN ECM AND TUMBLE GENERATOR VALVE POSITION SENSOR CONNECTOR.</p> <p>Measure the resistance of harness between tumble generator valve position sensor connector and engine ground.</p> <p>Connector & terminal (E50) No. 3 — Engine ground:</p>	<p>Is the resistance more than 1 MΩ?</p>	<p>Go to step 9.</p>	<p>Repair the ground short circuit in harness between tumble generator valve position sensor and ECM connector.</p>
<p>9</p> <p>CHECK POOR CONTACT.</p> <p>Check poor contact in tumble generator valve position sensor connector.</p>	<p>Is there poor contact in tumble generator valve position sensor connector?</p>	<p>Repair the poor contact in tumble generator valve position sensor connector.</p>	<p>Replace the tumble generator valve assembly. <Ref. to FU(H4DOTC)-34, Tumble Generator Valve Assembly.></p>

DIAGNOSTIC PROCEDURE WITH DIAGNOSTIC TROUBLE CODE (DTC)

ENGINE (DIAGNOSTICS)

CI: DTC P1087 — TUMBLE GENERATED VALVE POSITION SENSOR 2 CIRCUIT HIGH —

DTC DETECTING CONDITION:

- Immediately at fault recognition
- GENERAL DESCRIPTION <Ref. to GD(H4DOTC)-199, DTC P1087 — TUMBLE GENERATED VALVE POSITION SENSOR 2 CIRCUIT HIGH —, Diagnostic Trouble Code (DTC) Detecting Criteria.>

TROUBLE SYMPTOM:

- Erroneous idling
- Engine stalls.
- Poor driving performance

CAUTION:

After repair or replacement of faulty parts, conduct Clear Memory Mode <Ref. to EN(H4DOTC)-44, OPERATION, Clear Memory Mode.> and Inspection Mode <Ref. to EN(H4DOTC)-36, OPERATION, Inspection Mode.>.

WIRING DIAGRAM:

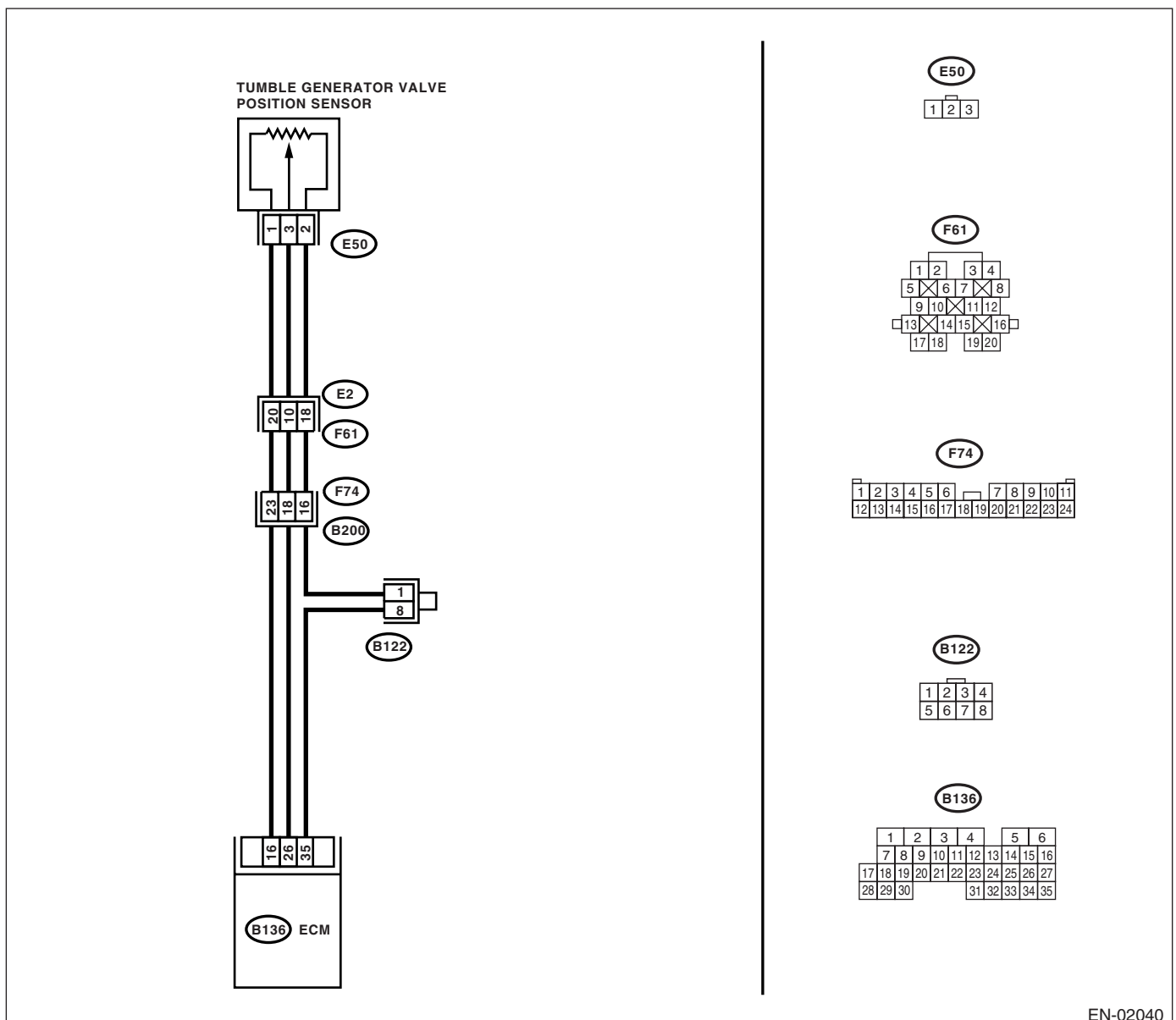

EN-02040

DIAGNOSTIC PROCEDURE WITH DIAGNOSTIC TROUBLE CODE (DTC)

ENGINE (DIAGNOSTICS)

Step	Check	Yes	No
<p>1</p> <p>CHECK CURRENT DATA.</p> <p>1) Start the engine.</p> <p>2) Read the data of throttle position sensor signal using Subaru Select Monitor or OBD-II general scan tool.</p> <p>NOTE:</p> <ul style="list-style-type: none"> • Subaru Select Monitor <p>For detailed operation procedure, refer to the "READ CURRENT DATA FOR ENGINE". <Ref. to EN(H4DOTC)-29, Subaru Select Monitor.></p> <ul style="list-style-type: none"> • OBD-II general scan tool <p>For detailed operation procedures, refer to the OBD-II General Scan Tool Instruction Manual.</p>	<p>Is the voltage more than 4.9 V?</p>	<p>Go to step 2.</p>	<p>Even if malfunction indicator light lights up, the circuit has returned to a normal condition at this time. A temporary poor contact of the connector may be the cause.</p> <p>NOTE:</p> <p>In this case, repair the following:</p> <ul style="list-style-type: none"> • Poor contact in tumble generator valve position sensor connector • Poor contact in ECM connector • Poor contact in coupling connector
<p>2</p> <p>CHECK HARNESS BETWEEN TUMBLE GENERATOR VALVE POSITION SENSOR AND ECM CONNECTOR.</p> <p>1) Turn the ignition switch to OFF.</p> <p>2) Disconnect the connector from throttle position sensor.</p> <p>3) Measure the resistance of harness between throttle position sensor connector and engine ground.</p> <p>Connector & terminal (E50) No. 2 — Engine ground:</p>	<p>Is the resistance less than 5 Ω?</p>	<p>Go to step 3.</p>	<p>Repair the harness and connector.</p> <p>NOTE:</p> <p>In this case, repair the following:</p> <ul style="list-style-type: none"> • Open circuit in harness between tumble generator valve position sensor and ECM connector • Poor contact in coupling connector • Poor contact in joint connector
<p>3</p> <p>CHECK HARNESS BETWEEN THROTTLE POSITION SENSOR AND ECM CONNECTOR.</p> <p>1) Turn the ignition switch to ON.</p> <p>2) Measure the voltage between throttle position sensor connector and engine ground.</p> <p>Connector & terminal (E50) No. 3 (+) — Engine ground (-):</p>	<p>Is the voltage more than 4.9 V?</p>	<p>Repair the battery short circuit in harness between tumble generator valve position sensor and ECM connector. After repair, replace the ECM. <Ref. to FU(H4DOTC)-42, Engine Control Module (ECM).></p>	<p>Replace the tumble generator valve assembly. <Ref. to FU(H4DOTC)-34, Tumble Generator Valve Assembly.></p>

DIAGNOSTIC PROCEDURE WITH DIAGNOSTIC TROUBLE CODE (DTC)

ENGINE (DIAGNOSTICS)

CJ: DTC P1088 — TUMBLE GENERATED VALVE POSITION SENSOR 1 CIRCUIT LOW —

DTC DETECTING CONDITION:

- Immediately at fault recognition
- GENERAL DESCRIPTION <Ref. to GD(H4DOTC)-201, DTC P1088 — TUMBLE GENERATED VALVE POSITION SENSOR 1 CIRCUIT LOW —, Diagnostic Trouble Code (DTC) Detecting Criteria.>

TROUBLE SYMPTOM:

- Erroneous idling
- Engine stalls.
- Poor driving performance

CAUTION:

After repair or replacement of faulty parts, conduct Clear Memory Mode <Ref. to EN(H4DOTC)-44, OPERATION, Clear Memory Mode.> and Inspection Mode <Ref. to EN(H4DOTC)-36, OPERATION, Inspection Mode.>.

WIRING DIAGRAM:

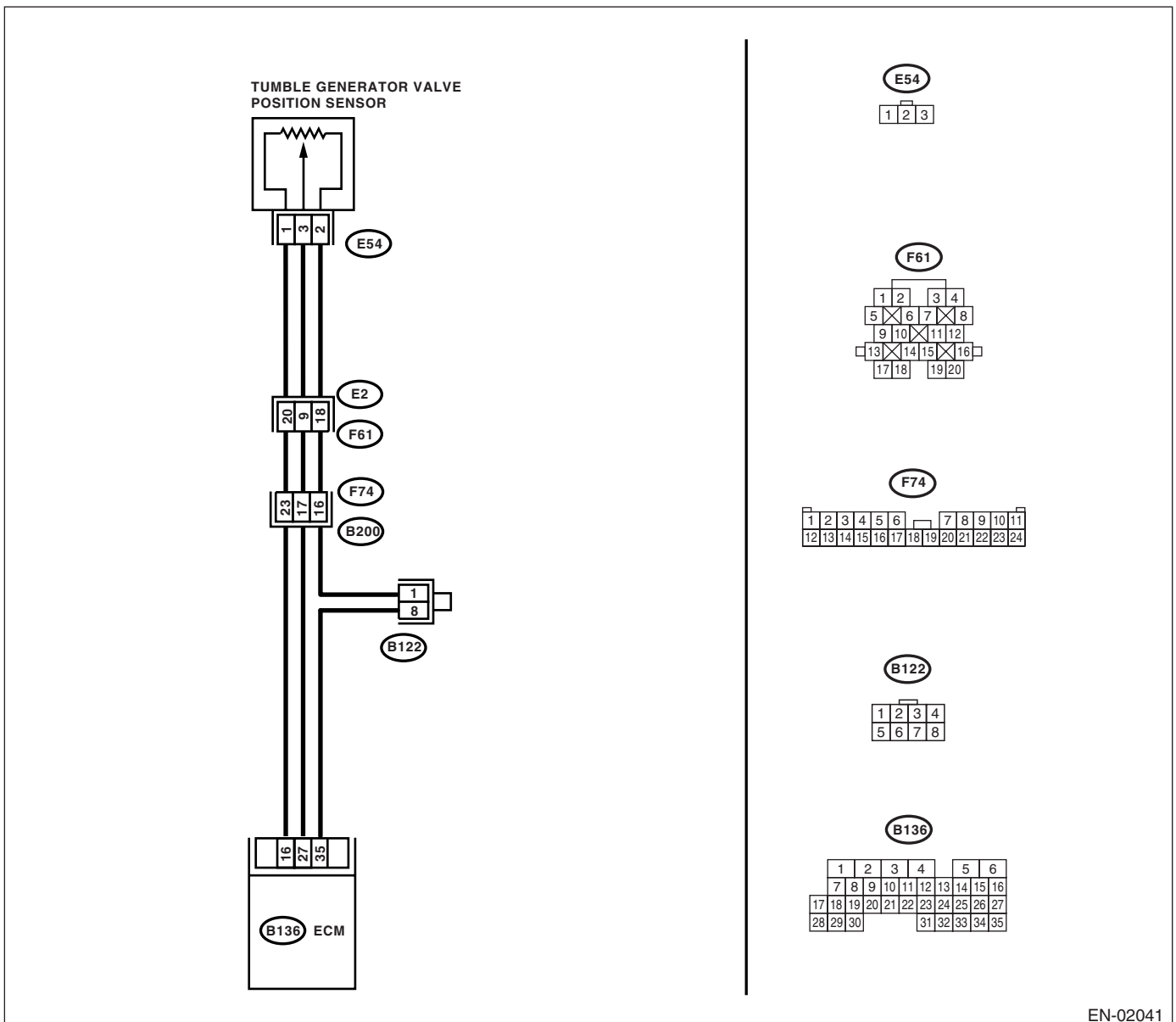

EN-02041

DIAGNOSTIC PROCEDURE WITH DIAGNOSTIC TROUBLE CODE (DTC)

ENGINE (DIAGNOSTICS)

Step	Check	Yes	No
1 CHECK CURRENT DATA. 1) Start the engine. 2) Read the data of tumble generator valve position sensor signal using Subaru Select Monitor or OBD-II general scan tool. NOTE: • Subaru Select Monitor For detailed operation procedure, refer to the "READ CURRENT DATA FOR ENGINE". <Ref. to EN(H4DOTC)-29, Subaru Select Monitor.> • OBD-II general scan tool For detailed operation procedures, refer to the OBD-II General Scan Tool Instruction Manual.	Is the voltage less than 0.1 V?	Go to step 2.	Even if malfunction indicator light lights up, the circuit has returned to a normal condition at this time. A temporary poor contact of the connector may be the cause. NOTE: In this case, repair the following: • Poor contact in tumble generator valve position sensor connector • Poor contact in ECM connector • Poor contact in coupling connector
2 CHECK INPUT SIGNAL FOR ECM. Measure the voltage between ECM connector and chassis ground while throttle valve is fully closed. Connector & terminal (B136) No. 16 (+) — Chassis ground (-):	Is the voltage more than 4.5 V?	Go to step 4.	Go to step 3.
3 CHECK INPUT SIGNAL FOR ECM. Measure the voltage between ECM connector and chassis ground. Connector & terminal (B136) No. 16 (+) — Chassis ground (-):	Shake the ECM harness and connector, while monitoring value of voltage meter. Does the voltage change?	Repair the poor contact in ECM connector.	Contact your SOA Service Center. NOTE: Inspection by DTM is required, because probable cause is deterioration of multiple parts.
4 CHECK INPUT SIGNAL FOR ECM. Measure the voltage between ECM connector and chassis ground. Connector & terminal (B136) No. 27 (+) — Chassis ground (-):	Is the voltage less than 0.1 V?	Go to step 6.	Go to step 5.
5 CHECK INPUT SIGNAL FOR ECM. (USING SUBARU SELECT MONITOR) Measure the voltage between ECM connector and chassis ground.	Shake the ECM harness and connector, while monitoring value of Subaru Select Monitor. Does the voltage change?	Repair the poor contact in ECM connector.	Go to step 6.

DIAGNOSTIC PROCEDURE WITH DIAGNOSTIC TROUBLE CODE (DTC)

ENGINE (DIAGNOSTICS)

Step	Check	Yes	No
<p>6 CHECK HARNESS BETWEEN ECM AND TUMBLE GENERATOR VALVE POSITION SENSOR CONNECTOR. 1) Turn the ignition switch to OFF. 2) Disconnect the connectors from throttle position sensor. 3) Turn the ignition switch to ON. 4) Measure the voltage between throttle position sensor connector and engine ground. Connector & terminal (E54) No. 1 (+) — Engine ground (-):</p>	Is the voltage more than 4.5 V?	Go to step 7.	Repair the harness and connector. NOTE: In this case, repair the following: <ul style="list-style-type: none"> • Open circuit in harness between tumble generator valve position sensor and ECM connector • Poor contact in throttle position sensor connector • Poor contact in ECM connector • Poor contact in coupling connector • Poor contact in joint connector
<p>7 CHECK HARNESS BETWEEN ECM AND TUMBLE GENERATOR VALVE POSITION SENSOR CONNECTOR. 1) Turn the ignition switch to OFF. 2) Measure the resistance of harness between ECM connector and throttle position sensor connector. Connector & terminal (B136) No. 27 — (E54) No. 3:</p>	Is the resistance less than 1 Ω ?	Go to step 8.	Repair the harness and connector. NOTE: In this case, repair the following: <ul style="list-style-type: none"> • Open circuit in harness between tumble generator valve position sensor and ECM connector • Poor contact in ECM connector • Poor contact in tumble generator valve position sensor connector • Poor contact in coupling connector
<p>8 CHECK HARNESS BETWEEN ECM AND THROTTLE POSITION SENSOR CONNECTOR. Measure the resistance of harness between tumble generator valve position sensor connector and engine ground. Connector & terminal (E54) No. 3 — Engine ground:</p>	Is the resistance more than 1 M Ω ?	Go to step 9.	Repair the ground short circuit in harness between tumble generator valve position sensor and ECM connector.
<p>9 CHECK POOR CONTACT. Check poor contact in tumble generator valve position sensor connector.</p>	Is there poor contact in tumble generator valve position sensor connector?	Repair the poor contact in tumble generator valve position sensor connector.	Replace the tumble generator valve assembly. <Ref. to FU(H4DOTC)-34, Tumble Generator Valve Assembly.>

CK:DTC P1089 — TUMBLE GENERATED VALVE POSITION SENSOR 1 CIRCUIT HIGH —

DTC DETECTING CONDITION:

- Immediately at fault recognition
- GENERAL DESCRIPTION <Ref. to GD(H4DOTC)-203, DTC P1089 — TUMBLE GENERATED VALVE POSITION SENSOR 1 CIRCUIT HIGH —, Diagnostic Trouble Code (DTC) Detecting Criteria.>

TROUBLE SYMPTOM:

- Erroneous idling
- Engine stalls.
- Poor driving performance

CAUTION:

After repair or replacement of faulty parts, conduct Clear Memory Mode <Ref. to EN(H4DOTC)-44, OPERATION, Clear Memory Mode.> and Inspection Mode <Ref. to EN(H4DOTC)-36, OPERATION, Inspection Mode.>.

WIRING DIAGRAM:

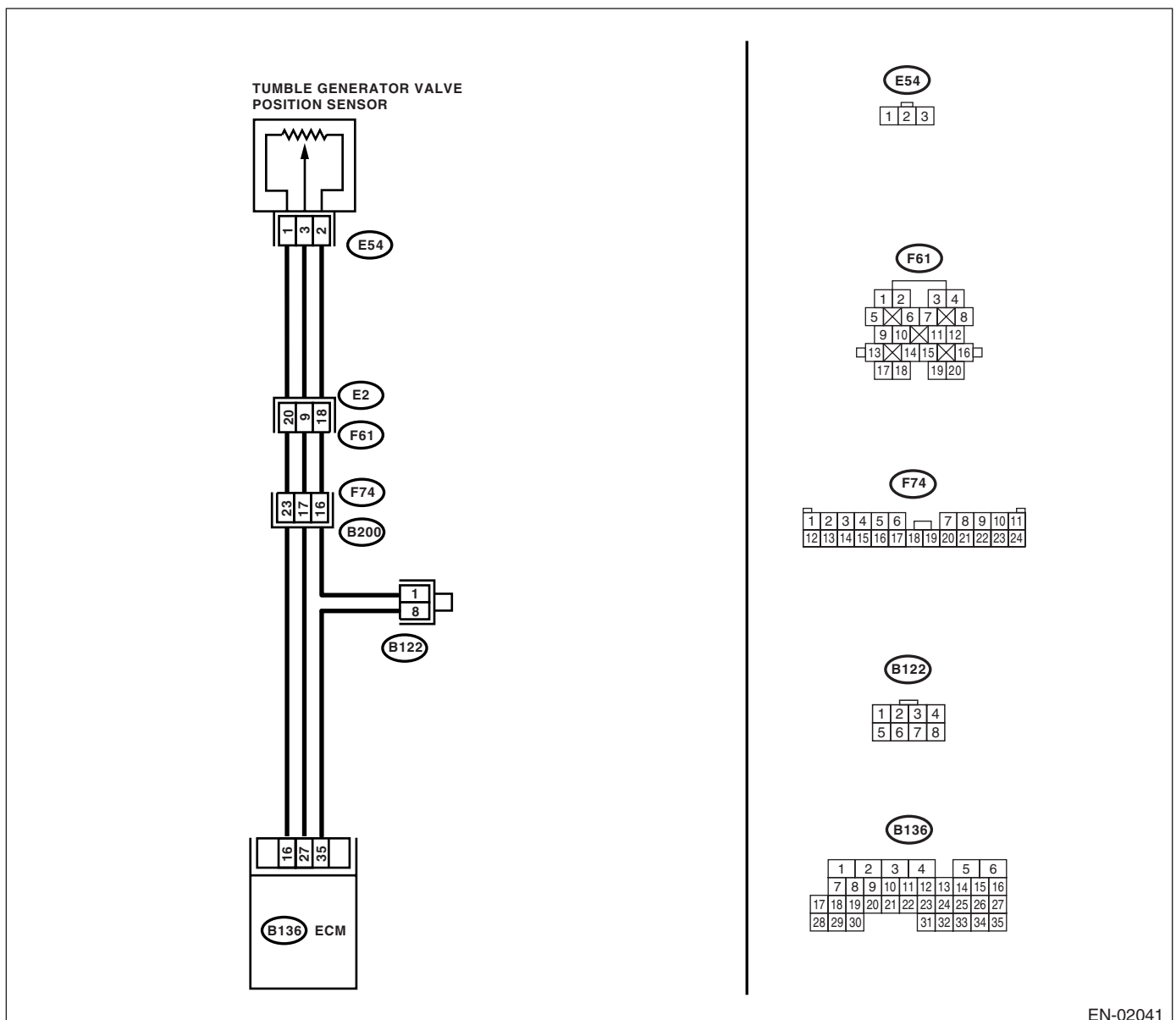

EN-02041

DIAGNOSTIC PROCEDURE WITH DIAGNOSTIC TROUBLE CODE (DTC)

ENGINE (DIAGNOSTICS)

Step	Check	Yes	No
<p>1</p> <p>CHECK CURRENT DATA.</p> <p>1) Start the engine.</p> <p>2) Read the data of tumble generator valve position sensor signal using Subaru Select Monitor or OBD-II general scan tool.</p> <p>NOTE:</p> <ul style="list-style-type: none"> Subaru Select Monitor <p>For detailed operation procedure, refer to the "READ CURRENT DATA FOR ENGINE". <Ref. to EN(H4DOTC)-29, Subaru Select Monitor.></p> <ul style="list-style-type: none"> OBD-II general scan tool <p>For detailed operation procedures, refer to the OBD-II General Scan Tool Instruction Manual.</p>	<p>Is the voltage more than 4.9 V?</p>	<p>Go to step 2.</p>	<p>Even if malfunction indicator light lights up, the circuit has returned to a normal condition at this time. A temporary poor contact of the connector may be the cause.</p> <p>NOTE:</p> <p>In this case, repair the following:</p> <ul style="list-style-type: none"> Poor contact in tumble generator valve position sensor connector Poor contact in ECM connector Poor contact in coupling connector
<p>2</p> <p>CHECK HARNESS BETWEEN TUMBLE GENERATOR VALVE POSITION SENSOR AND ECM CONNECTOR.</p> <p>1) Turn the ignition switch to OFF.</p> <p>2) Disconnect the connector from throttle position sensor.</p> <p>3) Measure the resistance of harness between tumble generator valve position sensor connector and engine ground.</p> <p>Connector & terminal (E54) No. 2 — Engine ground:</p>	<p>Is the resistance less than 5 Ω?</p>	<p>Go to step 3.</p>	<p>Repair the harness and connector.</p> <p>NOTE:</p> <p>In this case, repair the following:</p> <ul style="list-style-type: none"> Open circuit in harness between tumble generator valve position sensor and ECM connector Poor contact in coupling connector Poor contact in joint connector
<p>3</p> <p>CHECK HARNESS BETWEEN TUMBLE GENERATOR VALVE POSITION SENSOR AND ECM CONNECTOR.</p> <p>1) Turn the ignition switch to ON.</p> <p>2) Measure the voltage between throttle position sensor connector and engine ground.</p> <p>Connector & terminal (E54) No. 3 (+) — Engine ground (-):</p>	<p>Is the voltage more than 4.9 V?</p>	<p>Repair the battery short circuit in harness between tumble generator valve position sensor and ECM connector. After repair, replace the ECM. <Ref. to FU(H4DOTC)-42, Engine Control Module (ECM).></p>	<p>Replace the tumble generator valve assembly. <Ref. to FU(H4DOTC)-34, Tumble Generator Valve Assembly.></p>

DIAGNOSTIC PROCEDURE WITH DIAGNOSTIC TROUBLE CODE (DTC) —

ENGINE (DIAGNOSTICS)

CL:DTC P1090 — TUMBLE GENERATED VALVE SYSTEM 1 (VALVE OPEN) —

DTC DETECTING CONDITION:

- Immediately at fault recognition
- GENERAL DESCRIPTION <Ref. to GD(H4DOTC)-205, DTC P1090 — TUMBLE GENERATED VALVE SYSTEM 1 (VALVE OPEN) —, Diagnostic Trouble Code (DTC) Detecting Criteria.>

CAUTION:

After repair or replacement of faulty parts, conduct Clear Memory Mode <Ref. to EN(H4DOTC)-44, OPERATION, Clear Memory Mode.> and Inspection Mode <Ref. to EN(H4DOTC)-36, OPERATION, Inspection Mode.>.

Step	Check	Yes	No
1 CHECK ANY OTHER DTC ON DISPLAY.	Is any other DTC displayed?	Inspect the relevant DTC using "List of Diagnostic Trouble Code (DTC)". <Ref. to EN(H4DOTC)-68, List of Diagnostic Trouble Code (DTC).>	Go to step 2.
2 CHECK TUMBLE GENERATOR VALVE RH. 1) Remove the tumble generator valve assembly. 2) Check the tumble generator valve body.	Does the tumble generator valve move smoothly? (No dirt or foreign materials clogged)	Replace the tumble generator valve assembly. <Ref. to FU(H4DOTC)-34, Tumble Generator Valve Assembly.>	Clean the tumble generator valve.

DIAGNOSTIC PROCEDURE WITH DIAGNOSTIC TROUBLE CODE (DTC)

ENGINE (DIAGNOSTICS)

CM:DTC P1091 — TUMBLE GENERATED VALVE SYSTEM 1 (VALVE CLOSE) — DTC DETECTING CONDITION:

- Immediately at fault recognition
- GENERAL DESCRIPTION <Ref. to GD(H4DOTC)-206, DTC P1091 — TUMBLE GENERATED VALVE SYSTEM 1 (VALVE CLOSE) —, Diagnostic Trouble Code (DTC) Detecting Criteria.>

CAUTION:

After repair or replacement of faulty parts, conduct Clear Memory Mode <Ref. to EN(H4DOTC)-44, OPERATION, Clear Memory Mode.> and Inspection Mode <Ref. to EN(H4DOTC)-36, OPERATION, Inspection Mode.>.

Step	Check	Yes	No
1 CHECK ANY OTHER DTC ON DISPLAY.	Is any other DTC displayed?	Inspect the relevant DTC using "List of Diagnostic Trouble Code (DTC)" <Ref. to EN(H4DOTC)-68, List of Diagnostic Trouble Code (DTC).>	Go to step 2.
2 CHECK TUMBLE GENERATOR VALVE RH. 1) Remove the tumble generator valve assembly. 2) Check the tumble generator valve body.	Does the tumble generator valve move smoothly? (No dirt or foreign materials clogged)	Replace the tumble generator valve assembly. <Ref. to FU(H4DOTC)-34, Tumble Generator Valve Assembly.>	Clean the tumble generator valve.

DIAGNOSTIC PROCEDURE WITH DIAGNOSTIC TROUBLE CODE (DTC) —

ENGINE (DIAGNOSTICS)

CN:DTC P1092 — TUMBLE GENERATED VALVE SYSTEM 2 (VALVE OPEN) —

DTC DETECTING CONDITION:

- Immediately at fault recognition
- GENERAL DESCRIPTION <Ref. to GD(H4DOTC)-207, DTC P1092 — TUMBLE GENERATED VALVE SYSTEM 2 (VALVE OPEN) —, Diagnostic Trouble Code (DTC) Detecting Criteria.>

CAUTION:

After repair or replacement of faulty parts, conduct Clear Memory Mode <Ref. to EN(H4DOTC)-44, OPERATION, Clear Memory Mode.> and Inspection Mode <Ref. to EN(H4DOTC)-36, OPERATION, Inspection Mode.>.

Step	Check	Yes	No
1 CHECK ANY OTHER DTC ON DISPLAY.	Is any other DTC displayed?	Inspect the relevant DTC using "List of Diagnostic Trouble Code (DTC)". <Ref. to EN(H4DOTC)-68, List of Diagnostic Trouble Code (DTC).>	Go to step 2.
2 CHECK TUMBLE GENERATOR VALVE RH. 1) Remove the tumble generator valve assembly. 2) Check the tumble generator valve body.	Does the tumble generator valve move smoothly? (No dirt or foreign materials clogged)	Replace the tumble generator valve assembly. <Ref. to FU(H4DOTC)-34, Tumble Generator Valve Assembly.>	Clean the tumble generator valve.

DIAGNOSTIC PROCEDURE WITH DIAGNOSTIC TROUBLE CODE (DTC)

ENGINE (DIAGNOSTICS)

CO:DTC P1093 — TUMBLE GENERATED VALVE SYSTEM 2 (VALVE CLOSE) — DTC DETECTING CONDITION:

- Immediately at fault recognition
- GENERAL DESCRIPTION <Ref. to GD(H4DOTC)-208, DTC P1093 — TUMBLE GENERATED VALVE SYSTEM 2 (VALVE CLOSE) —, Diagnostic Trouble Code (DTC) Detecting Criteria.>

CAUTION:

After repair or replacement of faulty parts, conduct Clear Memory Mode <Ref. to EN(H4DOTC)-44, OPERATION, Clear Memory Mode.> and Inspection Mode <Ref. to EN(H4DOTC)-36, OPERATION, Inspection Mode.>.

Step	Check	Yes	No
1 CHECK ANY OTHER DTC ON DISPLAY.	Is any other DTC displayed?	Inspect the relevant DTC using "List of Diagnostic Trouble Code (DTC)". <Ref. to EN(H4DOTC)-68, List of Diagnostic Trouble Code (DTC).>	Go to step 2.
2 CHECK TUMBLE GENERATOR VALVE RH. 1) Remove the tumble generator valve assembly. 2) Check the tumble generator valve body.	Does the tumble generator valve move smoothly? (No dirt or foreign materials clogged)	Replace the tumble generator valve assembly. <Ref. to FU(H4DOTC)-34, Tumble Generator Valve Assembly.>	Clean the tumble generator valve.

CP:DTC P1094 — TUMBLE GENERATED VALVE SIGNAL 1 CIRCUIT MALFUNCTION (OPEN) —

DTC DETECTING CONDITION:

- Immediately at fault recognition
- GENERAL DESCRIPTION <Ref. to GD(H4DOTC)-209, DTC P1094 — TUMBLE GENERATED VALVE SIGNAL 1 CIRCUIT MALFUNCTION (OPEN) —, Diagnostic Trouble Code (DTC) Detecting Criteria.>

CAUTION:

After repair or replacement of faulty parts, conduct Clear Memory Mode <Ref. to EN(H4DOTC)-44, OPERATION, Clear Memory Mode.> and Inspection Mode <Ref. to EN(H4DOTC)-36, OPERATION, Inspection Mode.>.

WIRING DIAGRAM:

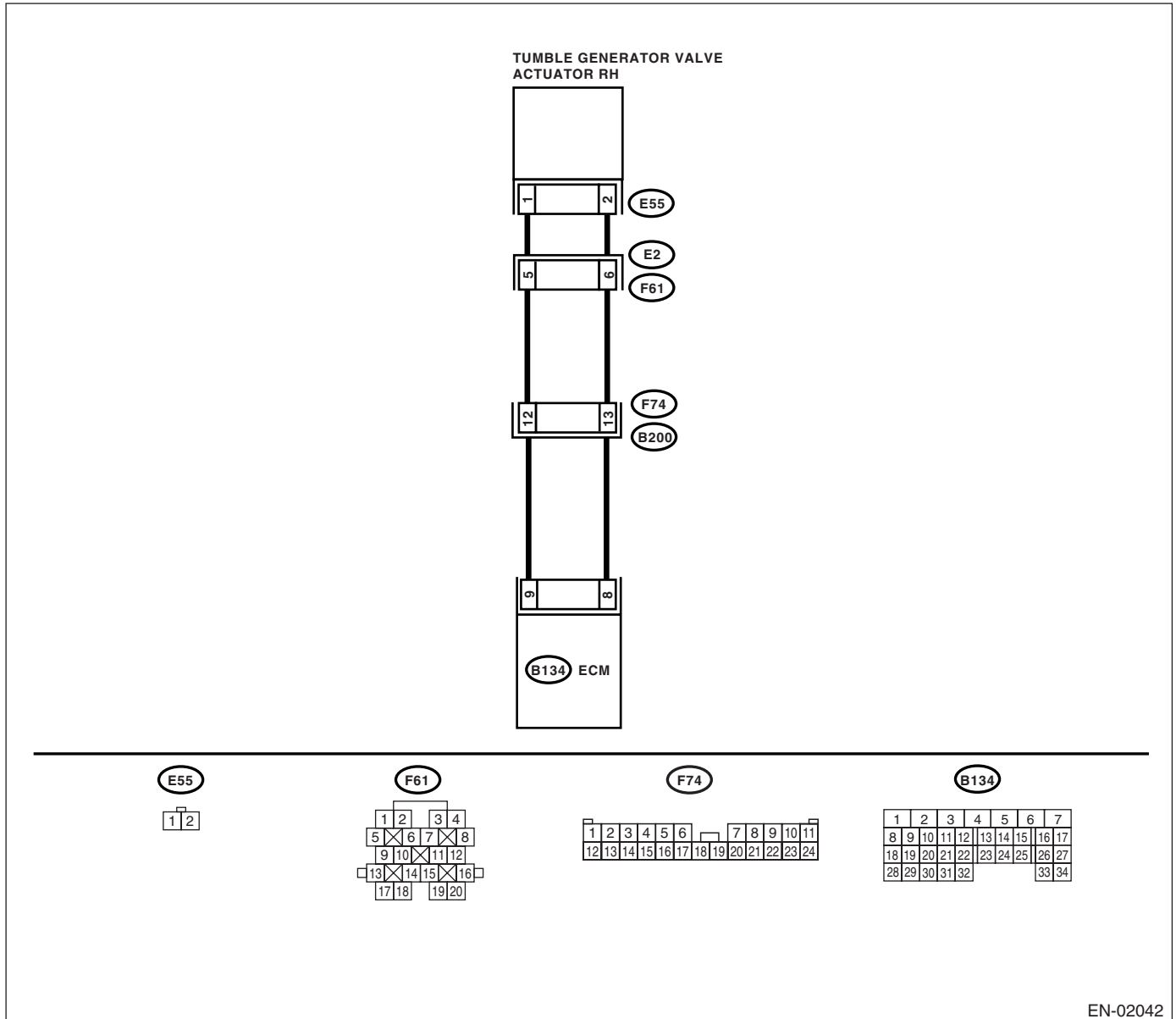

EN-02042

DIAGNOSTIC PROCEDURE WITH DIAGNOSTIC TROUBLE CODE (DTC)

ENGINE (DIAGNOSTICS)

Step	Check	Yes	No
<p>1</p> <p>CHECK HARNESS BETWEEN ECM AND TUMBLE GENERATOR VALVE ACTUATOR CONNECTOR.</p> <p>1) Turn the ignition switch to OFF. 2) Disconnect the connector from tumble generator valve and ECM connector. 3) Measure the resistance between tumble generator valve actuator and ECM connector.</p> <p>Connector & terminal (E55) No. 1 — (B134) No. 9: (E55) No. 2 — (B134) No. 8:</p>	<p>Is the resistance less than 1 Ω?</p>	<p>Go to step 2.</p>	<p>Repair the open circuit between ECM and tumble generator valve connector.</p> <p>NOTE: In this case, repair the following:</p> <ul style="list-style-type: none"> • Open circuit in harness between ECM and tumble generator valve actuator connector. • Poor contact in coupling connector.
<p>2</p> <p>CHECK POOR CONTACT. Check poor contact in tumble generator valve actuator connector.</p>	<p>Is there poor contact in tumble generator valve actuator connector?</p>	<p>Repair the poor contact in tumble generator valve actuator connector.</p>	<p>Replace the tumble generator valve assembly. <Ref. to FU(H4DOTC)-34, Tumble Generator Valve Assembly.></p>

CQ:DTC P1095 — TUMBLE GENERATED VALVE SIGNAL 1 CIRCUIT MALFUNCTION (SHORT) —

DTC DETECTING CONDITION:

- Immediately at fault recognition
- GENERAL DESCRIPTION <Ref. to GD(H4DOTC)-211, DTC P1095 — TUMBLE GENERATED VALVE SIGNAL 1 CIRCUIT MALFUNCTION (SHORT) —, Diagnostic Trouble Code (DTC) Detecting Criteria.>

CAUTION:

After repair or replacement of faulty parts, conduct Clear Memory Mode <Ref. to EN(H4DOTC)-44, OPERATION, Clear Memory Mode.> and Inspection Mode <Ref. to EN(H4DOTC)-36, OPERATION, Inspection Mode.>.

WIRING DIAGRAM:

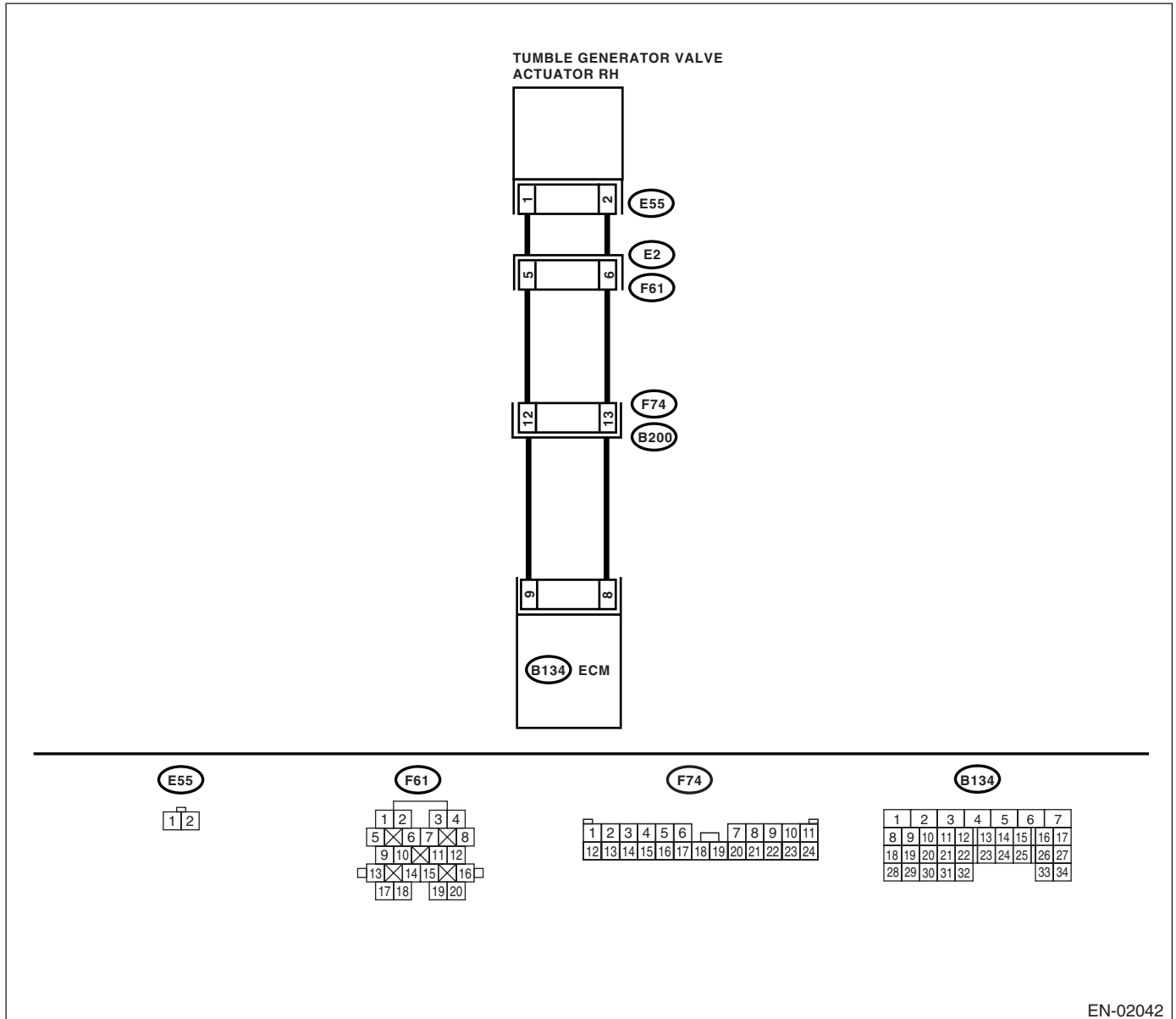

DIAGNOSTIC PROCEDURE WITH DIAGNOSTIC TROUBLE CODE (DTC)

ENGINE (DIAGNOSTICS)

Step	Check	Yes	No
<p>1</p> <p>CHECK HARNESS BETWEEN ECM AND TUMBLE GENERATOR VALVE ACTUATOR CONNECTOR.</p> <p>1) Turn the ignition switch to OFF. 2) Disconnect the connector from tumble generator valve connector. 3) Measure the voltage between tumble generator valve actuator and chassis ground.</p> <p>Connector & terminal (E55) No. 1 (+) — Chassis ground (-): (E55) No. 2 (+) — Chassis ground (-):</p>	Is the voltage less than 5 V?	Replace the tumble generator valve assembly. <Ref. to FU(H4DOTC)-34, Tumble Generator Valve Assembly.>	Repair the battery short circuit between ECM and tumble generator valve actuator.

CR:DTC P1096 — TUMBLE GENERATED VALVE SIGNAL 2 CIRCUIT MALFUNCTION (OPEN) —

DTC DETECTING CONDITION:

- Immediately at fault recognition
- GENERAL DESCRIPTION <Ref. to GD(H4DOTC)-213, DTC P1096 — TUMBLE GENERATED VALVE SIGNAL 2 CIRCUIT MALFUNCTION (OPEN) —, Diagnostic Trouble Code (DTC) Detecting Criteria.>

CAUTION:

After repair or replacement of faulty parts, conduct Clear Memory Mode <Ref. to EN(H4DOTC)-44, OPERATION, Clear Memory Mode.> and Inspection Mode <Ref. to EN(H4DOTC)-36, OPERATION, Inspection Mode.>.

WIRING DIAGRAM:

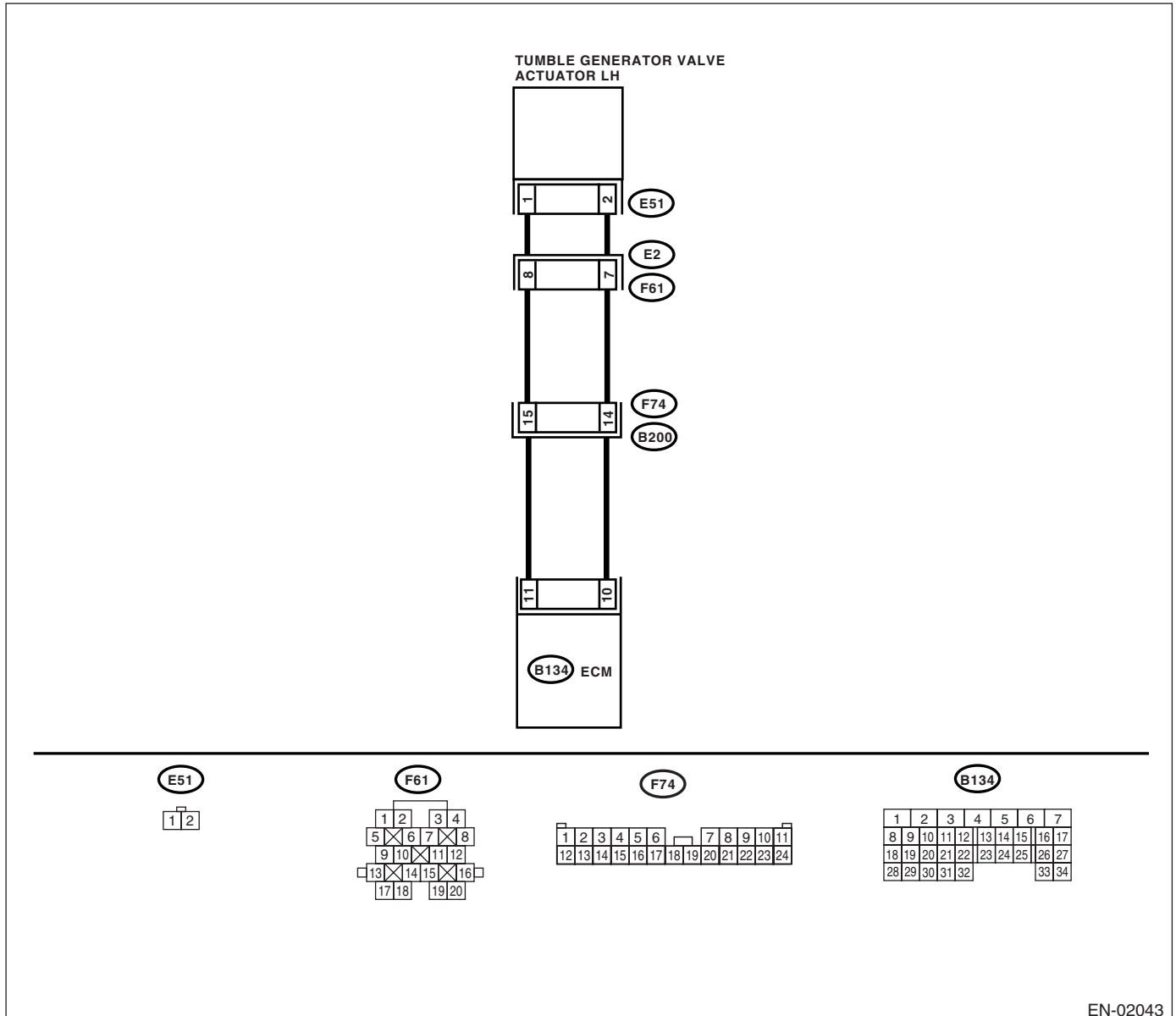

DIAGNOSTIC PROCEDURE WITH DIAGNOSTIC TROUBLE CODE (DTC)

ENGINE (DIAGNOSTICS)

	Step	Check	Yes	No
1	<p>CHECK HARNESS BETWEEN ECM AND TUMBLE GENERATOR VALVE ACTUATOR CONNECTOR.</p> <p>1) Turn the ignition switch to OFF. 2) Disconnect the connector from tumble generator valve and ECM connector. 3) Measure the resistance between tumble generator valve actuator and ECM connector.</p> <p>Connector & terminal (E51) No. 1 — (B134) No. 11: (E51) No. 2 — (B134) No. 10:</p>	<p>Is the resistance less than 1 Ω?</p>	<p>Go to step 2.</p>	<p>Repair the open circuit between ECM and tumble generator valve connector.</p> <p>NOTE: In this case, repair the following:</p> <ul style="list-style-type: none"> • Open circuit in harness between ECM and tumble generator valve actuator connector. • Poor contact in coupling connector.
2	<p>CHECK POOR CONTACT.</p> <p>Check poor contact in tumble generator valve actuator connector.</p>	<p>Is there poor contact in tumble generator valve actuator connector?</p>	<p>Repair the poor contact in tumble generator valve actuator connector.</p>	<p>Replace the tumble generator valve assembly. <Ref. to FU(H4DOTC)-34, Tumble Generator Valve Assembly.></p>

CS:DTC P1097 — TUMBLE GENERATED VALVE SIGNAL 2 CIRCUIT MALFUNCTION (SHORT) —

DTC DETECTING CONDITION:

- Immediately at fault recognition
- GENERAL DESCRIPTION <Ref. to GD(H4DOTC)-215, DTC P1097 — TUMBLE GENERATED VALVE SIGNAL 2 CIRCUIT MALFUNCTION (SHORT) —, Diagnostic Trouble Code (DTC) Detecting Criteria.>

CAUTION:

After repair or replacement of faulty parts, conduct Clear Memory Mode <Ref. to EN(H4DOTC)-44, OPERATION, Clear Memory Mode.> and Inspection Mode <Ref. to EN(H4DOTC)-36, OPERATION, Inspection Mode.>.

WIRING DIAGRAM:

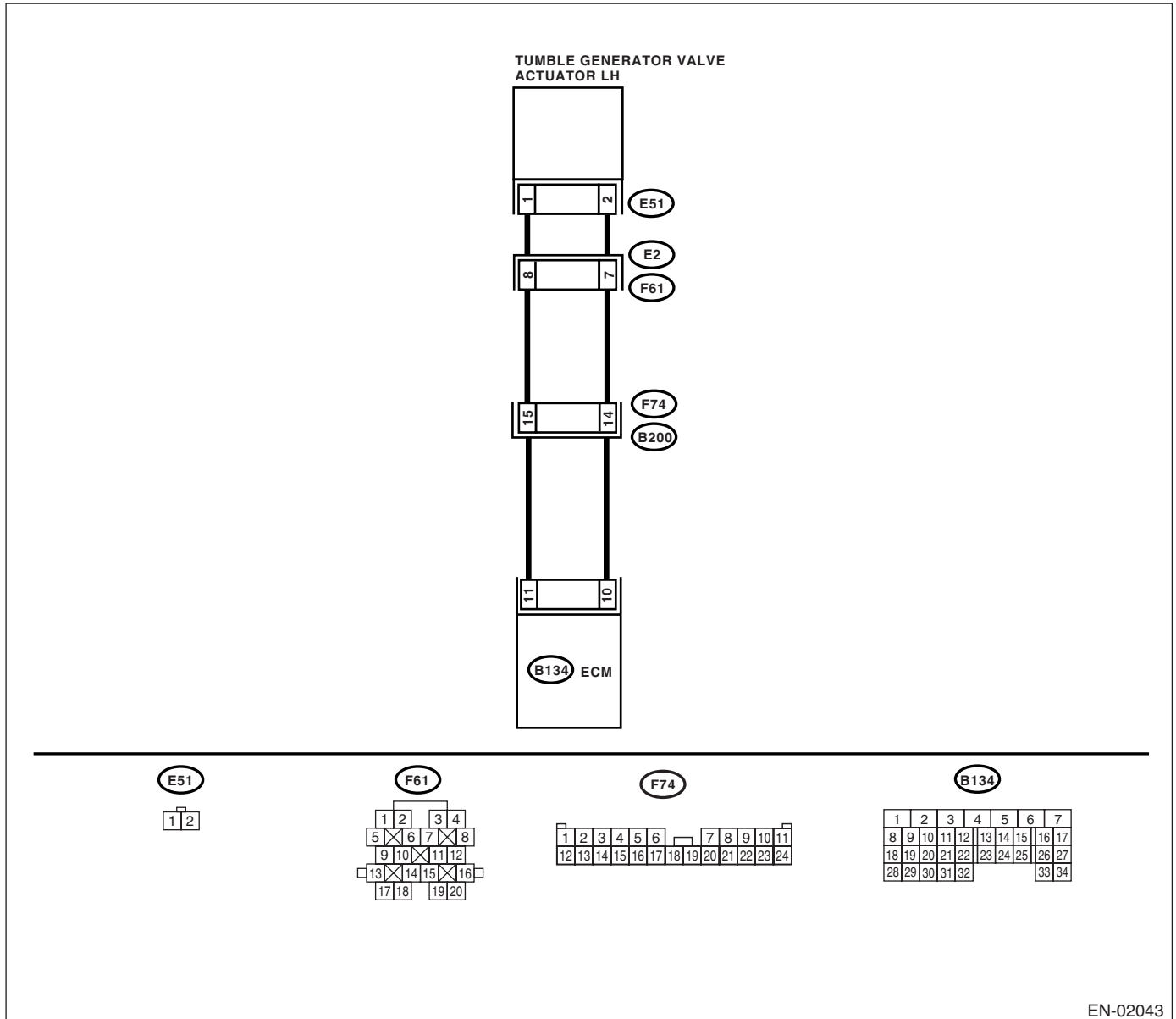

EN-02043

DIAGNOSTIC PROCEDURE WITH DIAGNOSTIC TROUBLE CODE (DTC)

ENGINE (DIAGNOSTICS)

Step	Check	Yes	No
<p>1</p> <p>CHECK HARNESS BETWEEN ECM AND TUMBLE GENERATOR VALVE ACTUATOR CONNECTOR.</p> <p>1) Turn the ignition switch to OFF. 2) Disconnect the connector from tumble generator valve connector. 3) Measure the voltage between tumble generator valve actuator and chassis ground.</p> <p>Connector & terminal (E51) No. 1 (+) — Chassis ground (-): (E51) No. 2 (+) — Chassis ground (-):</p>	<p>Is the voltage less than 5 V?</p>	<p>Replace the tumble generator valve assembly. <Ref. to FU(H4DOTC)-34, Tumble Generator Valve Assembly.></p>	<p>Repair the battery short circuit between ECM and tumble generator valve actuator.</p>

DIAGNOSTIC PROCEDURE WITH DIAGNOSTIC TROUBLE CODE (DTC)

ENGINE (DIAGNOSTICS)

CT:DTC P1110 — ATMOSPHERIC PRESSURE SENSOR CIRCUIT MALFUNCTION (LOW INPUT) —

DTC DETECTING CONDITION:

- Immediately at fault recognition
- GENERAL DESCRIPTION <Ref. to GD(H4DOTC)-217, DTC P1110 — ATMOSPHERIC PRESSURE SENSOR CIRCUIT MALFUNCTION (LOW INPUT) —, Diagnostic Trouble Code (DTC) Detecting Criteria.>

CAUTION:

After repair or replacement of faulty parts, conduct Clear Memory Mode <Ref. to EN(H4DOTC)-44, OPERATION, Clear Memory Mode.> and Inspection Mode <Ref. to EN(H4DOTC)-36, OPERATION, Inspection Mode.>.

Step	Check	Yes	No	
1	CHECK ANY OTHER DTC ON DISPLAY.	Does the Subaru Select Monitor or OBD-II general scan tool indicate DTC P1110?	Replace the ECM. <Ref. to FU(H4DOTC)-42, Engine Control Module (ECM).> NOTE: Atmospheric pressure sensor is built into ECM.	A temporary poor contact.

CU:DTC P1111 — ATMOSPHERIC PRESSURE SENSOR CIRCUIT MALFUNCTION (HIGH INPUT) —

DTC DETECTING CONDITION:

- Immediately at fault recognition
- GENERAL DESCRIPTION <Ref. to GD(H4DOTC)-218, DTC P1111 — ATMOSPHERIC PRESSURE SENSOR CIRCUIT MALFUNCTION (HIGH INPUT) —, Diagnostic Trouble Code (DTC) Detecting Criteria.>

CAUTION:

After repair or replacement of faulty parts, conduct Clear Memory Mode <Ref. to EN(H4DOTC)-44, OPERATION, Clear Memory Mode.> and Inspection Mode <Ref. to EN(H4DOTC)-36, OPERATION, Inspection Mode.>.

Step	Check	Yes	No	
1	CHECK ANY OTHER DTC ON DISPLAY.	Does the Subaru Select Monitor or OBD-II general scan tool indicate DTC P1111?	Replace the ECM. <Ref. to FU(H4DOTC)-42, Engine Control Module (ECM).> NOTE: Atmospheric pressure sensor is built into ECM.	A temporary poor contact.

DIAGNOSTIC PROCEDURE WITH DIAGNOSTIC TROUBLE CODE (DTC)

ENGINE (DIAGNOSTICS)

CV:DTC P1152 — O₂ SENSOR CIRCUIT RANGE/PERFORMANCE (LOW) (BANK 1 SENSOR 1) —

NOTE:

For the diagnostic procedure, refer to DTC P1153. <Ref. to EN(H4DOTC)-299, DTC P1153 — O₂ SENSOR CIRCUIT RANGE/PERFORMANCE (HIGH) (BANK1 SENSOR1) —, Diagnostic Procedure with Diagnostic Trouble Code (DTC).>

**CW: DTC P1153 — O₂ SENSOR CIRCUIT RANGE/PERFORMANCE (HIGH)
(BANK1 SENSOR1) —**

DTC DETECTING CONDITION:

- Two consecutive driving cycles with fault
- GENERAL DESCRIPTION <Ref. to GD(H4DOTC)-222, DTC P1153 — O₂ SENSOR CIRCUIT RANGE/PERFORMANCE (HIGH) (BANK1 SENSOR1) —, Diagnostic Trouble Code (DTC) Detecting Criteria.>

CAUTION:

After repair or replacement of faulty parts, conduct Clear Memory Mode <Ref. to EN(H4DOTC)-44, OPERATION, Clear Memory Mode.> and Inspection Mode <Ref. to EN(H4DOTC)-36, OPERATION, Inspection Mode.>.

WIRING DIAGRAM:

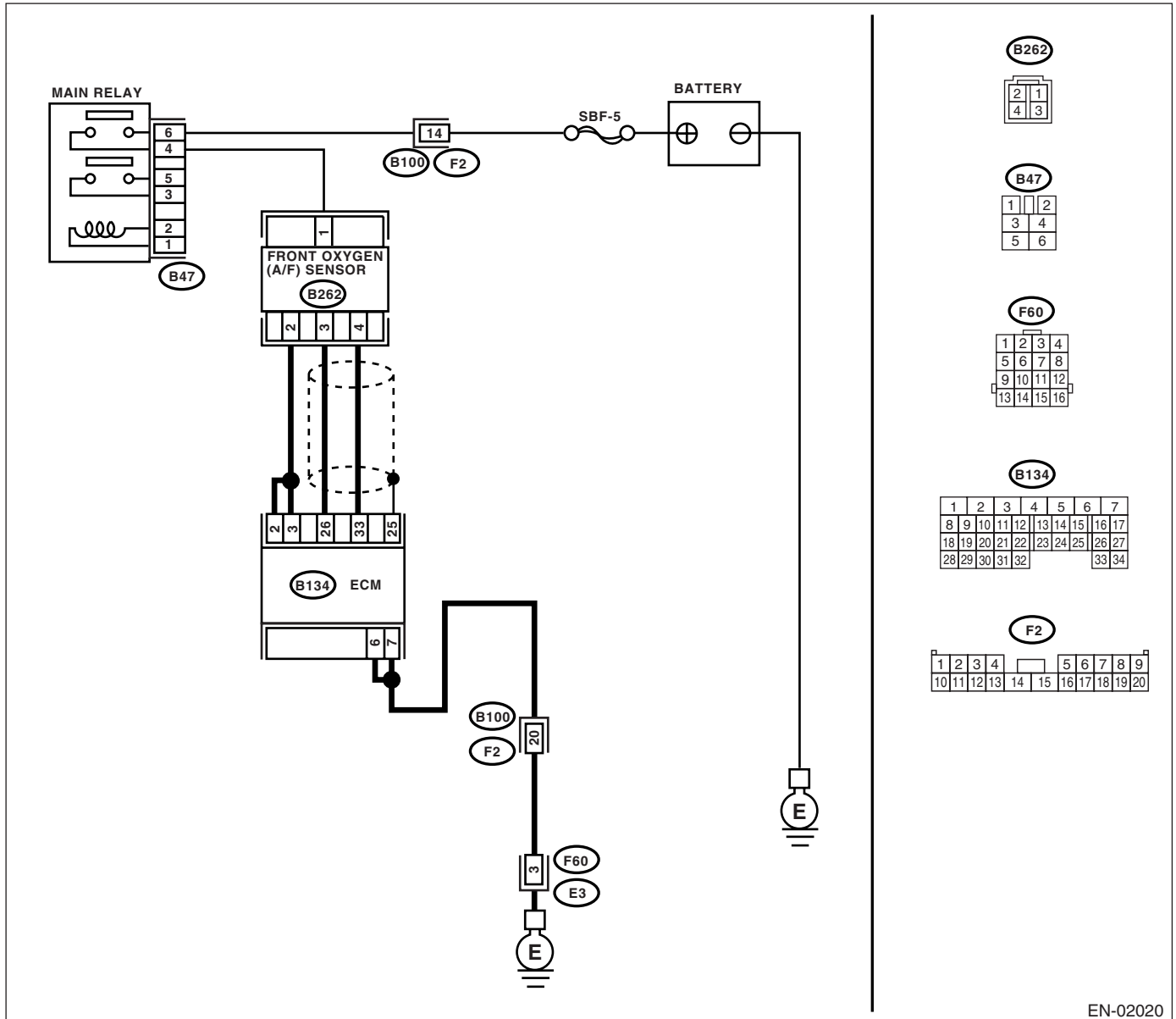

EN-02020

DIAGNOSTIC PROCEDURE WITH DIAGNOSTIC TROUBLE CODE (DTC)

ENGINE (DIAGNOSTICS)

Step	Check	Yes	No	
1	CHECK ANY OTHER DTC ON DISPLAY.	Is any other DTC displayed?	Inspect the relevant DTC using "List of Diagnostic Trouble Code (DTC)". <Ref. to EN(H4DOTC)-68, List of Diagnostic Trouble Code (DTC).>	
2	CHECK FRONT (A/F) OXYGEN SENSOR DATA. 1) Start engine. 2) While observing the Subaru Select Monitor or OBD-II general scan tool screen, warm-up the engine until coolant temperature is above 75°C (167°F). If the engine is already warmed-up, operate at idle speed for at least 1 minute. 3) Read data of front oxygen (A/F) sensor signal using Subaru Select Monitor or OBD-II general scan tool. NOTE: <ul style="list-style-type: none"> • Subaru Select Monitor For detailed operation procedure, refer to the "READ CURRENT DATA FOR ENGINE". <Ref. to EN(H4DOTC)-29, Subaru Select Monitor.> <ul style="list-style-type: none"> • OBD-II general scan tool For detailed operation procedures, refer to the OBD-II General Scan Tool Instruction Manual.	Is the measured value within 0.86 — 1.15 at idle?	Go to step 3.	Go to step 4.
3	CHECK REAR OXYGEN SENSOR SIGNAL. 1) Race engine at speeds from idling to 5,000 rpm for a total of 5 cycles. NOTE: To increase engine speed to 5,000 rpm, slowly depress accelerator pedal, taking approximately 5 seconds, and quickly release accelerator pedal to decrease engine speed. 2) Operate the LED operation mode for engine. NOTE: <ul style="list-style-type: none"> • Subaru Select Monitor For detailed operation procedure, refer to the "LED OPERATION MODE FOR ENGINE". <Ref. to EN(H4DOTC)-29, Subaru Select Monitor.>	Does the LED of {Rear O ₂ Rich Signal} blink?	Check front oxygen (A/F) sensor circuit.	Check rear oxygen sensor circuit. <Ref. to FU(H4DOTC)-39, Rear Oxygen Sensor.>
4	CHECK EXHAUST SYSTEM. Check exhaust system parts. NOTE: Check the following items. <ul style="list-style-type: none"> • Loose installation of portions • Damage (crack, hole etc.) of parts • Looseness of front oxygen (A/F) sensor • Looseness and ill fitting of parts between front oxygen (A/F) sensor and rear oxygen sensor 	Is there a fault in exhaust system?	Repair or replace faulty parts.	Replace front oxygen (A/F) sensor. <Ref. to FU(H4DOTC)-37, Front Oxygen (A/F) Sensor.>

CX:DTC P1160 — RETURN SPRING FAILURE —

NOTE:

For the diagnostic procedure, refer to DTC P2101. <Ref. to EN(H4DOTC)-348, DTC P2101 — THROTTLE ACTUATOR CONTROL MOTOR CIRCUIT RANGE/PERFORMANCE —, Diagnostic Procedure with Diagnostic Trouble Code (DTC).>

DIAGNOSTIC PROCEDURE WITH DIAGNOSTIC TROUBLE CODE (DTC)

ENGINE (DIAGNOSTICS)

CY:DTC P1301 — MISFIRE DETECTED (HIGH TEMPERATURE EXHAUST GAS)

DTC DETECTING CONDITION:

- Immediately at fault recognition
- GENERAL DESCRIPTION <Ref. to GD(H4DOTC)-227, DTC P1301 — MISFIRE DETECTED (HIGH TEMPERATURE EXHAUST GAS) —, Diagnostic Trouble Code (DTC) Detecting Criteria.>

TROUBLE SYMPTOM:

- Erroneous idling
- Engine stalls.
- Poor driving performance

CAUTION:

After repair or replacement of faulty parts, conduct Clear Memory Mode <Ref. to EN(H4DOTC)-44, OPERATION, Clear Memory Mode.> and Inspection Mode <Ref. to EN(H4DOTC)-36, OPERATION, Inspection Mode.>.

WIRING DIAGRAM:

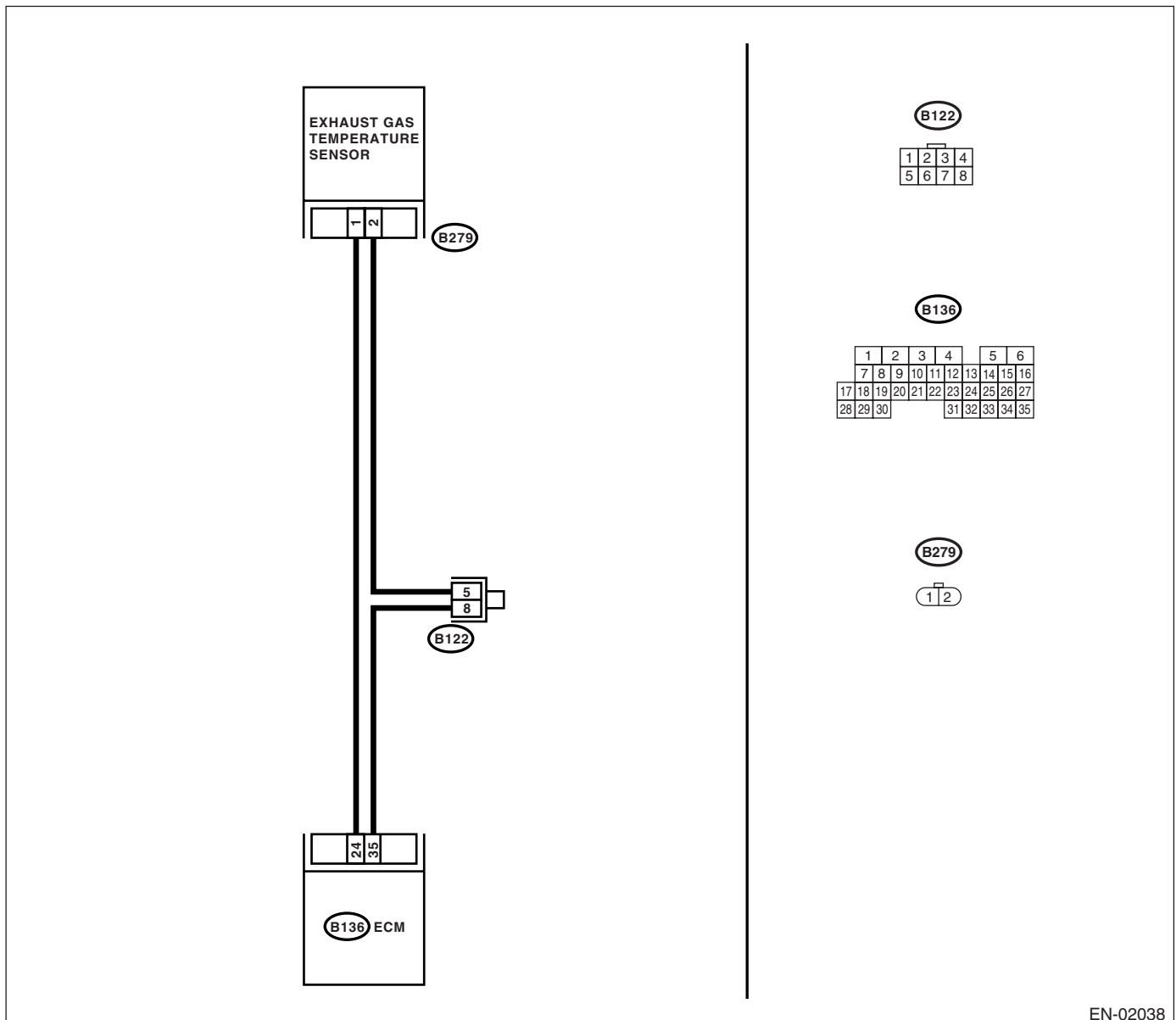

EN-02038

DIAGNOSTIC PROCEDURE WITH DIAGNOSTIC TROUBLE CODE (DTC)

ENGINE (DIAGNOSTICS)

	Step	Check	Yes	No
1	CHECK ANY OTHER DTC. Conduct the troubleshooting for all DTC P0301, P0302, P0303 and P0304. <Ref. to EN(H4DOTC)-68, List of Diagnostic Trouble Code (DTC).>	Does failure for repair or replacement exist?	Repair or replace the failure, then replace pre-catalytic converter.	Contact your SOA Service Center. NOTE: Inspection by DTM is required, because probable cause is deterioration of multiple parts.

DIAGNOSTIC PROCEDURE WITH DIAGNOSTIC TROUBLE CODE (DTC)

ENGINE (DIAGNOSTICS)

CZ:DTC P1312 — EXHAUST GAS TEMPERATURE SENSOR MALFUNCTION — DTC DETECTING CONDITION:

- Immediately at fault recognition
- GENERAL DESCRIPTION <Ref. to GD(H4DOTC)-229, DTC P1312 — EXHAUST GAS TEMPERATURE SENSOR MALFUNCTION —, Diagnostic Trouble Code (DTC) Detecting Criteria.>

CAUTION:

After repair or replacement of faulty parts, conduct Clear Memory Mode <Ref. to EN(H4DOTC)-44, OPERATION, Clear Memory Mode.> and Inspection Mode <Ref. to EN(H4DOTC)-36, OPERATION, Inspection Mode.>.

WIRING DIAGRAM:

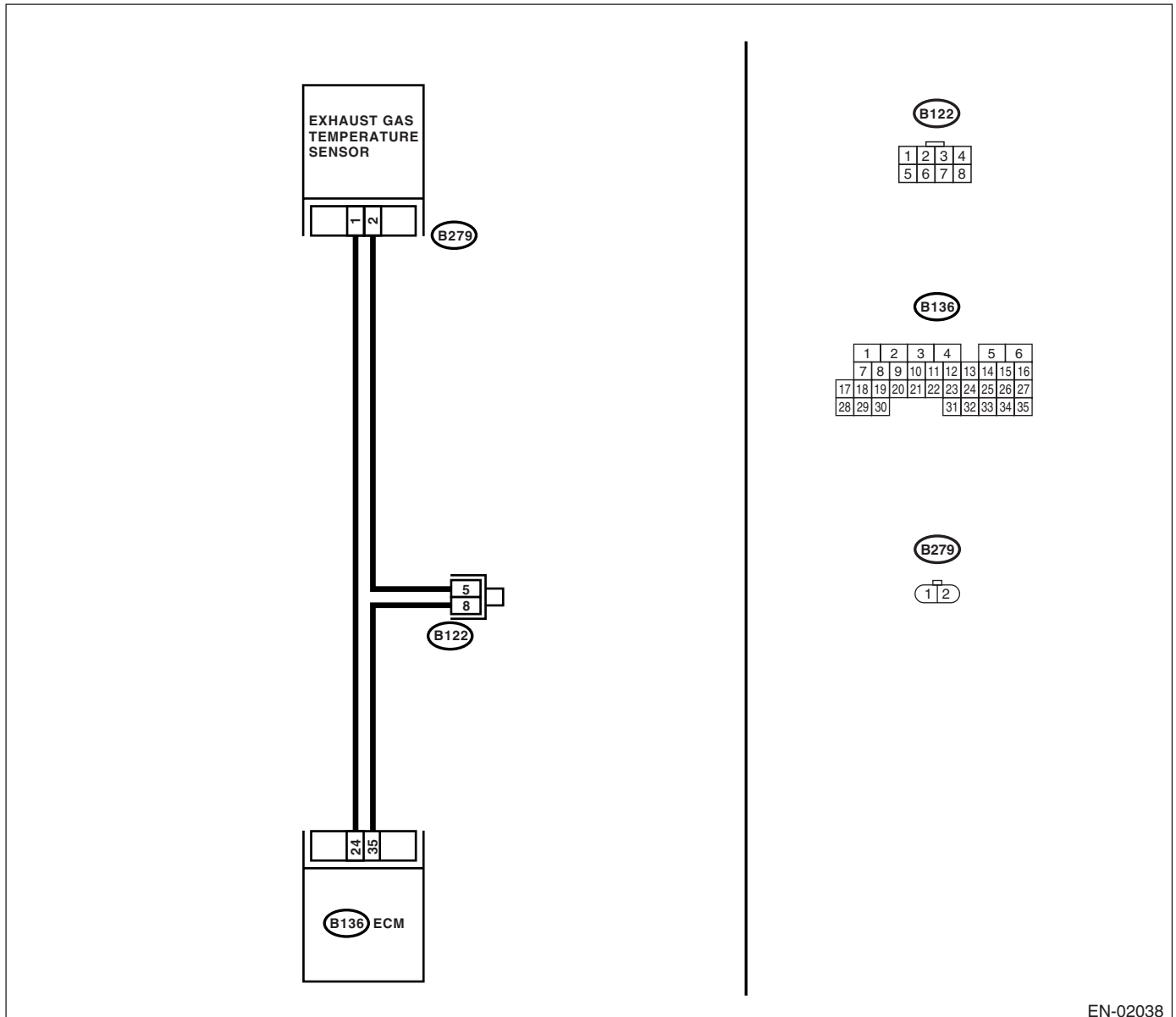

EN-02038

DIAGNOSTIC PROCEDURE WITH DIAGNOSTIC TROUBLE CODE (DTC)

ENGINE (DIAGNOSTICS)

Step	Check	Yes	No
1 CHECK ANY OTHER DTC ON DISPLAY.	Is any other DTC displayed?	Inspect the relevant DTC using "List of Diagnostic Trouble Code (DTC)". <Ref. to EN(H4DOTC)-68, List of Diagnostic Trouble Code (DTC).> NOTE: In this case, it is not necessary to inspect DTC P1312.	Replace the exhaust gas temperature sensor. <Ref. to FU(H4DOTC)-41, Exhaust Temperature Sensor.>

DIAGNOSTIC PROCEDURE WITH DIAGNOSTIC TROUBLE CODE (DTC)

ENGINE (DIAGNOSTICS)

DA:DTC P1400 — FUEL TANK PRESSURE CONTROL SOLENOID VALVE CIRCUIT LOW —

DTC DETECTING CONDITION:

- Two consecutive driving cycles with fault
- GENERAL DESCRIPTION <Ref. to GD(H4DOTC)-230, DTC P1400 — FUEL TANK PRESSURE CONTROL SOLENOID VALVE CIRCUIT LOW —, Diagnostic Trouble Code (DTC) Detecting Criteria.>

CAUTION:

After repair or replacement of faulty parts, conduct Clear Memory Mode <Ref. to EN(H4DOTC)-44, OPERATION, Clear Memory Mode.> and Inspection Mode <Ref. to EN(H4DOTC)-36, OPERATION, Inspection Mode.>.

WIRING DIAGRAM:

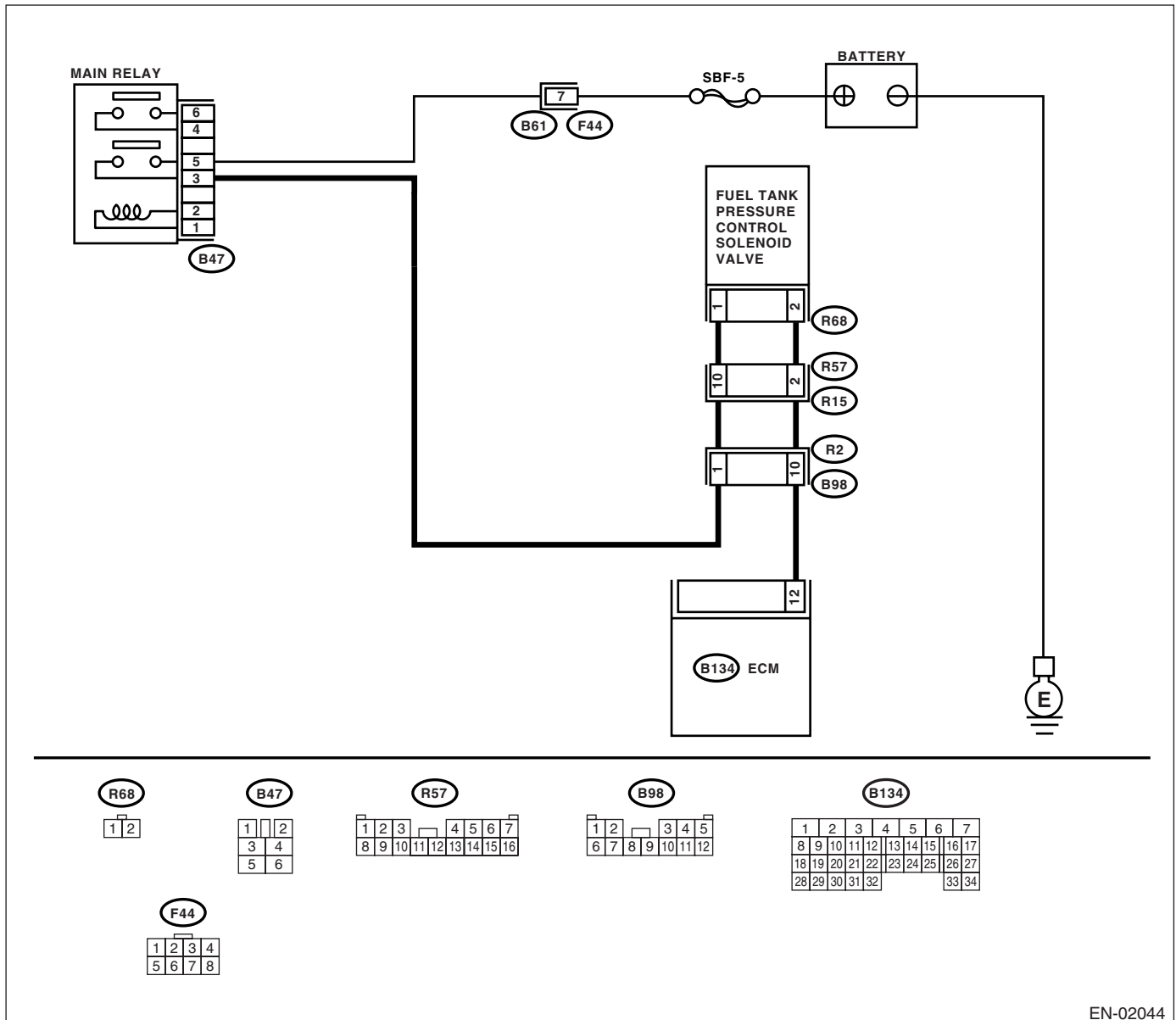

EN-02044

DIAGNOSTIC PROCEDURE WITH DIAGNOSTIC TROUBLE CODE (DTC)

ENGINE (DIAGNOSTICS)

Step	Check	Yes	No
1 CHECK OUTPUT SIGNAL FROM ECM. 1) Turn ignition switch to ON. 2) Measure the voltage between ECM and chassis ground. <i>Connector & terminal</i> <i>(B134) No. 12 (+) — Chassis ground (-):</i>	Is the voltage more than 10 V?	Go to step 2.	Go to step 3.
2 CHECK FOR POOR CONTACT. Check for poor contact in ECM connector.	Is there poor contact in ECM connector?	Repair poor contact in ECM connector.	Contact with SOA Service Center. NOTE: Inspection by DTM is required, because probable cause is deterioration of multiple parts.
3 CHECK HARNESS BETWEEN FUEL TANK PRESSURE CONTROL SOLENOID VALVE AND ECM CONNECTOR. 1) Turn ignition switch to OFF. 2) Disconnect the connectors from fuel tank pressure control solenoid valve and ECM. 3) Measure the resistance of harness between fuel tank pressure control solenoid valve connector and chassis ground. <i>Connector & terminal</i> <i>(R68) No. 2 — Chassis ground:</i>	Is the resistance more than 1 M Ω ?	Go to step 4.	Repair short circuit to ground in harness between ECM and fuel tank pressure control solenoid valve connector.
4 CHECK HARNESS BETWEEN FUEL TANK PRESSURE CONTROL SOLENOID VALVE AND ECM CONNECTOR. Measure the resistance of harness between ECM and fuel tank pressure control solenoid valve connector. <i>Connector & terminal</i> <i>(B134) No. 12 — (R68) No. 2:</i>	Is the resistance less than 1 Ω ?	Go to step 5.	Repair harness and connector. NOTE: In this case, repair the following: <ul style="list-style-type: none"> • Open circuit in harness between ECM and fuel tank pressure control solenoid valve connector • Poor contact in coupling connector
5 CHECK FUEL TANK PRESSURE CONTROL SOLENOID VALVE. Measure the resistance between fuel tank pressure control solenoid valve terminals. <i>Terminals</i> <i>No. 1 — No. 2:</i>	Is the resistance 10 — 100 Ω ?	Go to step 6.	Replace the fuel tank pressure control solenoid valve.<Ref. to EC(H4DOTC)-7, Purge Control Solenoid Valve.>

DIAGNOSTIC PROCEDURE WITH DIAGNOSTIC TROUBLE CODE (DTC)

ENGINE (DIAGNOSTICS)

Step	Check	Yes	No
<p>6</p> <p>CHECK POWER SUPPLY TO FUEL TANK PRESSURE CONTROL SOLENOID VALVE.</p> <p>1) Turn ignition switch to ON. 2) Measure the voltage between fuel tank pressure control solenoid valve and chassis ground.</p> <p>Connector & terminal (R68) No. 1 (+) — Chassis ground (-):</p>	<p>Is the voltage more than 10 V?</p>	<p>Go to step 7.</p>	<p>Repair harness and connector.</p> <p>NOTE: In this case, repair the following:</p> <ul style="list-style-type: none"> • Open circuit in harness between main relay and fuel tank pressure control solenoid valve connector • Poor contact in coupling connector • Poor contact in main relay connector
<p>7</p> <p>CHECK FOR POOR CONTACT.</p> <p>Check for poor contact in fuel tank pressure control solenoid valve connector.</p>	<p>Is there poor contact in fuel tank pressure control solenoid valve connector?</p>	<p>Repair poor contact in fuel tank pressure control solenoid valve connector.</p>	<p>Contact with SOA Service Center.</p> <p>NOTE: Inspection by DTM is required, because probable cause is deterioration of multiple parts.</p>

DB:DTC P1420 — FUEL TANK PRESSURE CONTROL SOL. VALVE CIRCUIT HIGH —

DTC DETECTING CONDITION:

- Two consecutive driving cycles with fault
- GENERAL DESCRIPTION <Ref. to GD(H4DOTC)-232, DTC P1420 — FUEL TANK PRESSURE CONTROL SOL. VALVE CIRCUIT HIGH —, Diagnostic Trouble Code (DTC) Detecting Criteria.>

CAUTION:

After repair or replacement of faulty parts, conduct Clear Memory Mode <Ref. to EN(H4DOTC)-44, OPERATION, Clear Memory Mode.> and Inspection Mode <Ref. to EN(H4DOTC)-36, OPERATION, Inspection Mode.>.

WIRING DIAGRAM:

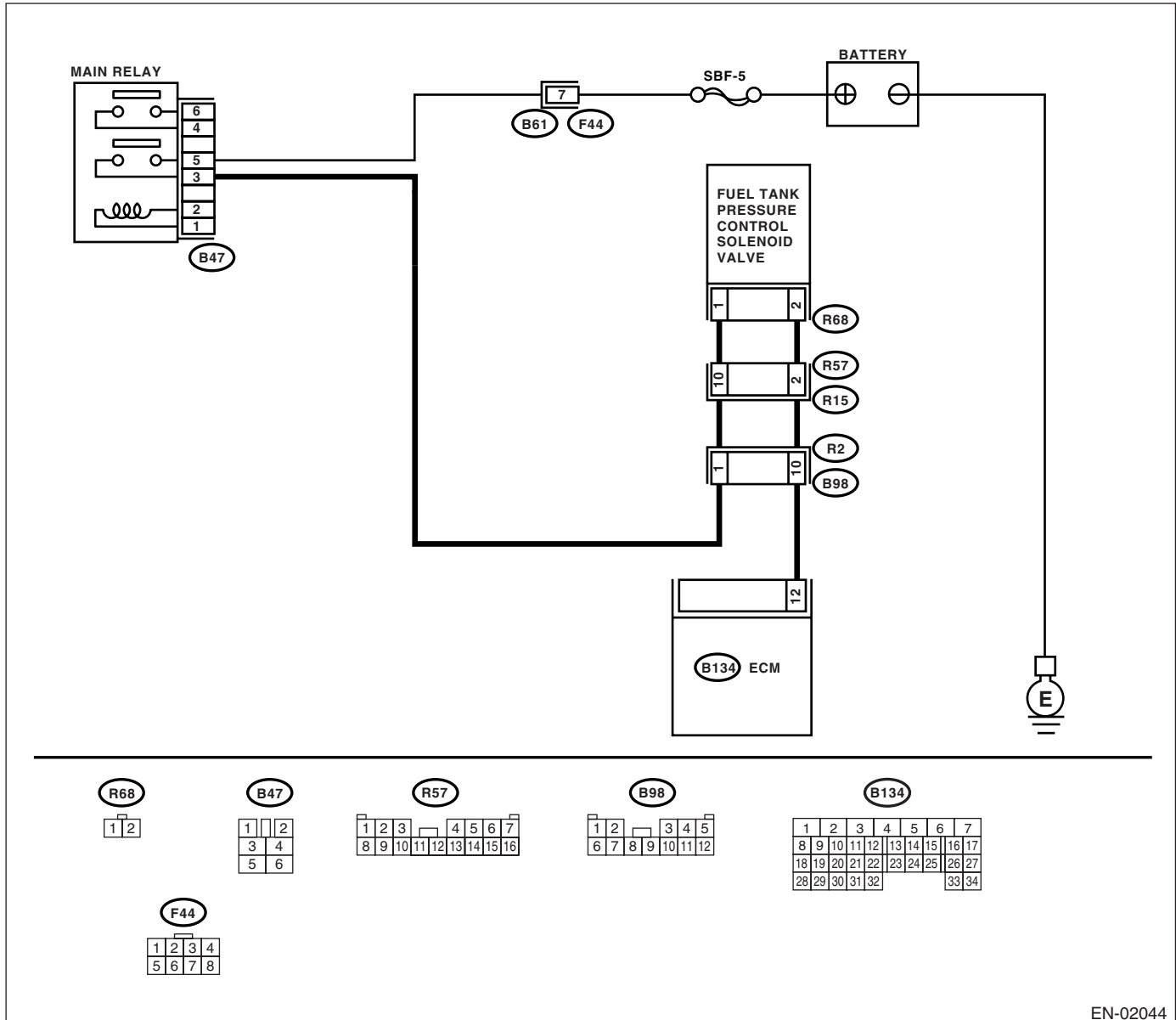

DIAGNOSTIC PROCEDURE WITH DIAGNOSTIC TROUBLE CODE (DTC)

ENGINE (DIAGNOSTICS)

Step	Check	Yes	No
<p>1</p> <p>CHECK INPUT SIGNAL FOR ECM.</p> <p>1) Turn ignition switch to OFF. 2) Connect the test mode connector at the lower portion of instrument panel (on the driver's side). 3) Turn ignition switch to ON. 4) While operating the fuel tank pressure control solenoid valve, measure voltage between ECM and chassis ground.</p> <p>NOTE: Fuel tank pressure control solenoid valve operation can be executed using Subaru Select Monitor. For the procedure, refer to "Compulsory Valve Operation Check Mode". <Ref. to EN(H4DOTC)-45, Compulsory Valve Operation Check Mode.></p> <p>Connector & terminal (B134) No. 12 (+) — Chassis ground (-):</p>	Does the voltage change 0 — 10 V?	Go to step 2.	The malfunction indicator light may light up, however, the circuit is returned to the normal status at the moment. In this case, repair poor contact in ECM connector.
<p>2</p> <p>CHECK INPUT SIGNAL FOR ECM.</p> <p>1) Turn ignition switch to ON. 2) Measure the voltage between ECM and chassis ground.</p> <p>Connector & terminal (B134) No. 12 (+) — Chassis ground (-):</p>	Is the voltage more than 10 V?	Go to step 4.	Go to step 3.
<p>3</p> <p>CHECK FOR POOR CONTACT.</p> <p>Check for poor contact in ECM connector.</p>	Is there poor contact in ECM connector?	Repair poor contact in ECM connector.	Replace the ECM. <Ref. to FU(H4DOTC)-42, Engine Control Module (ECM).>
<p>4</p> <p>CHECK HARNESS BETWEEN FUEL TANK PRESSURE CONTROL SOLENOID VALVE AND ECM CONNECTOR.</p> <p>1) Turn ignition switch to OFF. 2) Disconnect the connector from fuel tank pressure control solenoid valve. 3) Turn ignition switch to ON. 4) Measure the voltage between ECM and chassis ground.</p> <p>Connector & terminal (B134) No. 12 (+) — Chassis ground (-):</p>	Is the voltage more than 10 V?	Repair short circuit to battery in harness between ECM and fuel tank pressure control solenoid valve connector. After repair, replace the ECM. <Ref. to FU(H4DOTC)-42, Engine Control Module (ECM).>	Go to step 5.
<p>5</p> <p>CHECK FUEL TANK PRESSURE CONTROL SOLENOID VALVE.</p> <p>1) Turn ignition switch to OFF. 2) Measure the resistance between fuel tank pressure control solenoid valve terminals.</p> <p>Terminals No. 1 — No. 2:</p>	Is the resistance less than 1 Ω ?	Replace the fuel tank pressure control solenoid valve <Ref. to EC(H4DOTC)-13, Pressure Control Solenoid Valve.> and the ECM <Ref. to FU(H4DOTC)-42, Engine Control Module (ECM).>.	Go to step 6.
<p>6</p> <p>CHECK FOR POOR CONTACT.</p> <p>Check for poor contact in ECM connector.</p>	Is there poor contact in ECM connector?	Repair poor contact in ECM connector.	Replace the ECM. <Ref. to FU(H4DOTC)-42, Engine Control Module (ECM).>

**DC:DTC P1443 — VENT CONTROL SOLENOID VALVE FUNCTION PROBLEM —
DTC DETECTING CONDITION:**

- Immediately at fault recognition
- GENERAL DESCRIPTION <Ref. to GD(H4DOTC)-234, DTC P1443 — VENT CONTROL SOLENOID VALVE FUNCTION PROBLEM —, Diagnostic Trouble Code (DTC) Detecting Criteria.>

TROUBLE SYMPTOM:

Improper fuel supply

CAUTION:

After repair or replacement of faulty parts, conduct Clear Memory Mode <Ref. to EN(H4DOTC)-44, OPERATION, Clear Memory Mode.> and Inspection Mode <Ref. to EN(H4DOTC)-36, OPERATION, Inspection Mode.>.

WIRING DIAGRAM:

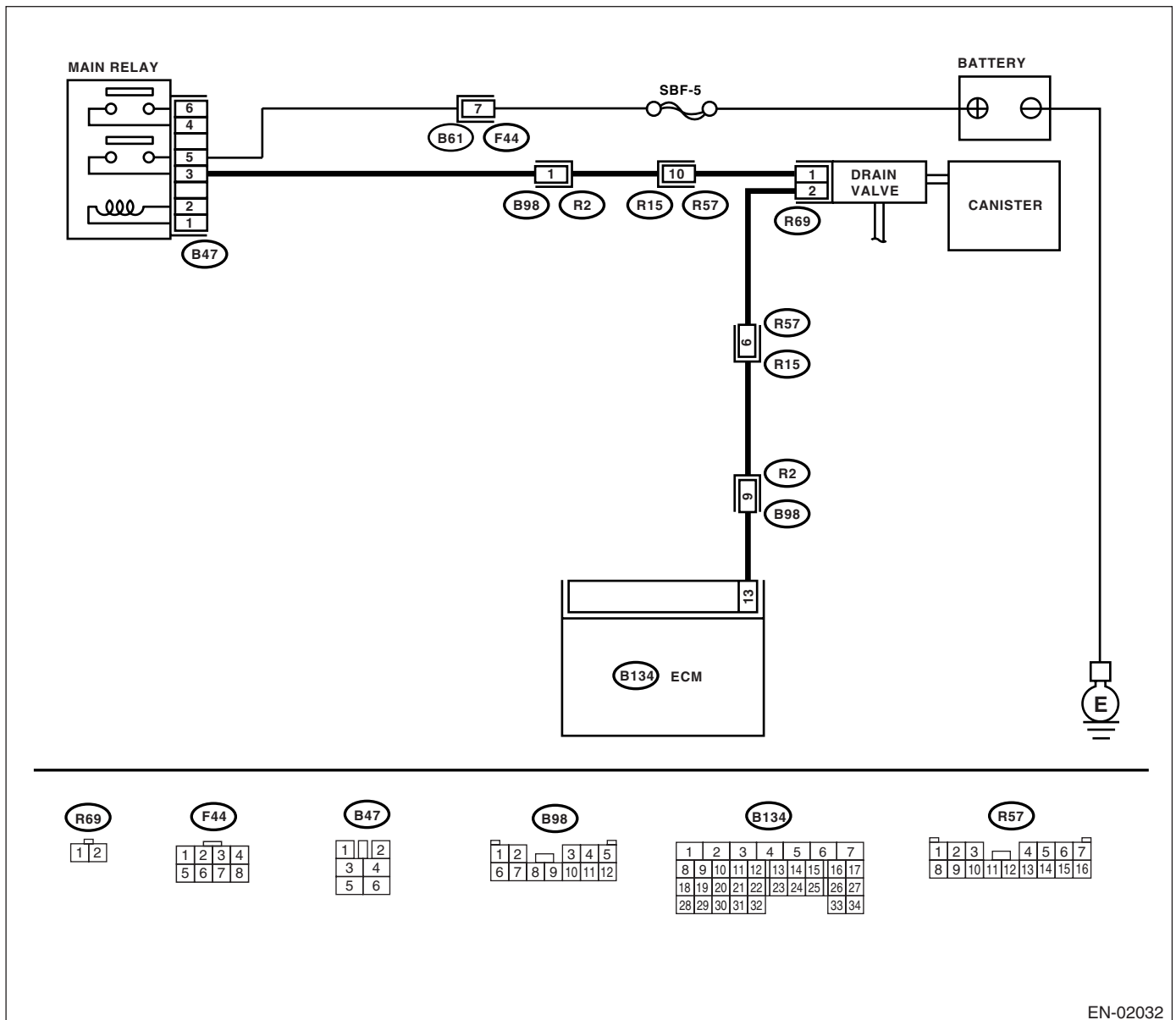

EN-02032

DIAGNOSTIC PROCEDURE WITH DIAGNOSTIC TROUBLE CODE (DTC)

ENGINE (DIAGNOSTICS)

Step	Check	Yes	No
1 CHECK FOR OTHER DTC ON DISPLAY.	Is any other DTC displayed?	Inspect the relevant DTC using "List of Diagnostic Trouble Code (DTC)". <Ref. to EN(H4DOTC)-68, List of Diagnostic Trouble Code (DTC).>	Go to step 2.
2 CHECK VENT LINE HOSES. Check the following items. <ul style="list-style-type: none">• Clogging of vent hoses between canister and drain valve• Clogging of vent hose between drain valve and air filter• Clogging of drain filter	Is there a fault in vent line?	Repair or replace faulty parts.	Go to step 3.
3 CHECK DRAIN VALVE OPERATION. 1) Turn ignition switch to OFF. 2) Connect the test mode connector at the lower portion of instrument panel (on the driver's side). 3) Turn ignition switch to ON. 4) Operate the drain valve. NOTE: Drain valve operation can also be executed using Subaru Select Monitor. For the procedure, refer to "Compulsory Valve Operation Check Mode". <Ref. to EN(H4DOTC)-45, Compulsory Valve Operation Check Mode.>	Does the drain valve operate?	Contact with SOA Service Center. NOTE: Inspection by DTM is required, because probable cause is deterioration of multiple parts.	Replace the drain valve. <Ref. to EC(H4DOTC)-19, Drain Valve.>

DIAGNOSTIC PROCEDURE WITH DIAGNOSTIC TROUBLE CODE (DTC)

ENGINE (DIAGNOSTICS)

DD:DTC P1446 — FUEL TANK SENSOR CONTROL VALVE CIRCUIT LOW — DTC DETECTING CONDITION:

- Two consecutive driving cycles with fault
- GENERAL DESCRIPTION <Ref. to GD(H4DOTC)-235, DTC P1446 — FUEL TANK SENSOR CONTROL VALVE CIRCUIT LOW —, Diagnostic Trouble Code (DTC) Detecting Criteria.>

CAUTION:

After repair or replacement of faulty parts, conduct Clear Memory Mode <Ref. to EN(H4DOTC)-44, OPERATION, Clear Memory Mode.> and Inspection Mode <Ref. to EN(H4DOTC)-36, OPERATION, Inspection Mode.>.

WIRING DIAGRAM:

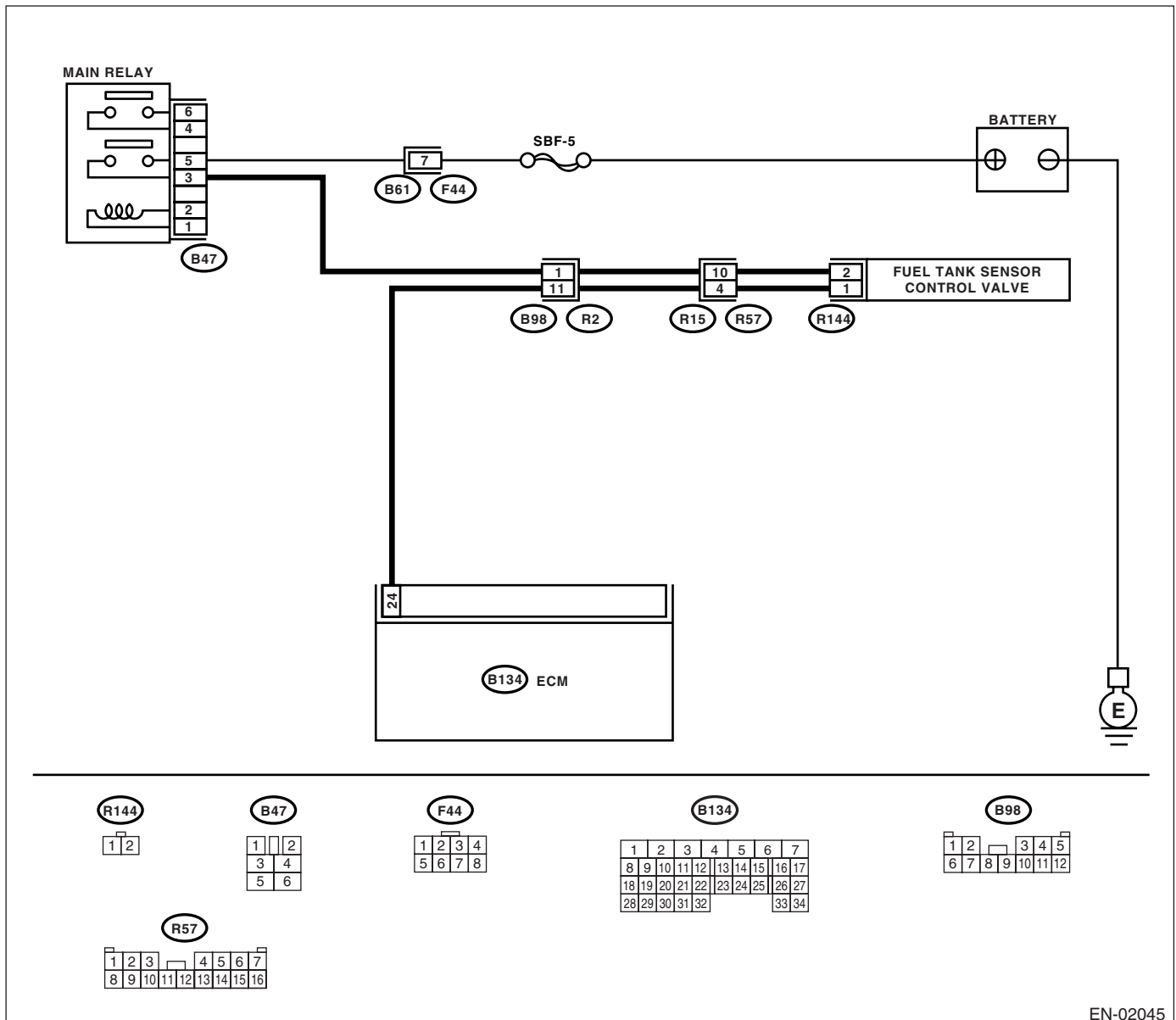

EN-02045

DIAGNOSTIC PROCEDURE WITH DIAGNOSTIC TROUBLE CODE (DTC)

ENGINE (DIAGNOSTICS)

Step	Check	Yes	No
1 CHECK OUTPUT SIGNAL FROM ECM. 1) Turn ignition switch to ON. 2) Measure the voltage between ECM and chassis ground. Connector & terminal (B134) No. 24 (+) — Chassis ground (-):	Is the voltage more than 10 V?	Go to step 2.	Go to step 3.
2 CHECK FOR POOR CONTACT. Check for poor contact in ECM connector.	Is there poor contact in ECM connector?	Repair poor contact in ECM connector.	The malfunction indicator light may light up, however, the circuit is returned to the normal status at the moment. (However, the possibility of poor contact still remains.) NOTE: In this case, repair the following: <ul style="list-style-type: none"> • Poor contact in fuel tank sensor control valve connector • Poor contact in ECM connector • Poor contact in coupling connector
3 CHECK HARNESS BETWEEN FUEL TANK SENSOR CONTROL VALVE AND ECM CONNECTOR. 1) Turn ignition switch to OFF. 2) Disconnect the connectors from fuel tank sensor control valve and ECM. 3) Measure the resistance of harness between fuel tank sensor control valve connector and chassis ground. Connector & terminal (R144) No. 2 — Chassis ground:	Is the resistance more than 1 M Ω ?	Go to step 4.	Repair short circuit to ground in harness between ECM and fuel tank sensor control valve connector.
4 CHECK HARNESS BETWEEN FUEL TANK SENSOR CONTROL VALVE AND ECM CONNECTOR. Measure the resistance of harness between ECM and fuel tank sensor control valve connector. Connector & terminal (B134) No. 24 — (R144) No. 2:	Is the resistance less than 1 Ω ?	Go to step 5.	Repair harness and connector. NOTE: In this case, repair the following: <ul style="list-style-type: none"> • Open circuit in harness between ECM and fuel tank sensor control valve connector • Poor contact in coupling connector
5 CHECK FUEL TANK SENSOR CONTROL VALVE. Measure the resistance between fuel tank sensor control valve terminals. Terminals No. 1 — No. 2:	Is the resistance 10 — 100 Ω ?	Go to step 6.	Replace the fuel tank sensor control valve. <Ref. to EC(H4DOTC)-19, Drain Valve.>

DIAGNOSTIC PROCEDURE WITH DIAGNOSTIC TROUBLE CODE (DTC)

ENGINE (DIAGNOSTICS)

Step	Check	Yes	No
<p>6</p> <p>CHECK POWER SUPPLY TO FUEL TANK SENSOR CONTROL VALVE.</p> <p>1) Turn ignition switch to ON. 2) Measure the voltage between fuel tank sensor control valve and chassis ground.</p> <p>Connector & terminal (R144) No. 1 (+) — Chassis ground (-):</p>	Is the voltage more than 10 V?	Go to step 7.	<p>Repair harness and connector.</p> <p>NOTE: In this case, repair the following:</p> <ul style="list-style-type: none"> • Open circuit in harness between main relay and fuel tank sensor control valve • Poor contact in coupling connector • Poor contact in main relay connector
<p>7</p> <p>CHECK FOR POOR CONTACT.</p> <p>Check for poor contact in fuel tank sensor control valve connector.</p>	Is there poor contact in fuel tank sensor control valve connector?	Repair poor contact in fuel tank sensor control valve connector.	<p>Contact with SOA Service Center.</p> <p>NOTE: Inspection by DTM is required, because probable cause is deterioration of multiple parts.</p>

DIAGNOSTIC PROCEDURE WITH DIAGNOSTIC TROUBLE CODE (DTC)

ENGINE (DIAGNOSTICS)

DE:DTC P1447 — FUEL TANK SENSOR CONTROL VALVE CIRCUIT HIGH — DTC DETECTING CONDITION:

- Two consecutive driving cycles with fault
- GENERAL DESCRIPTION <Ref. to GD(H4DOTC)-237, DTC P1447 — FUEL TANK SENSOR CONTROL VALVE CIRCUIT HIGH —, Diagnostic Trouble Code (DTC) Detecting Criteria.>

CAUTION:

After repair or replacement of faulty parts, conduct Clear Memory Mode <Ref. to EN(H4DOTC)-44, OPERATION, Clear Memory Mode.> and Inspection Mode <Ref. to EN(H4DOTC)-36, OPERATION, Inspection Mode.>.

WIRING DIAGRAM:

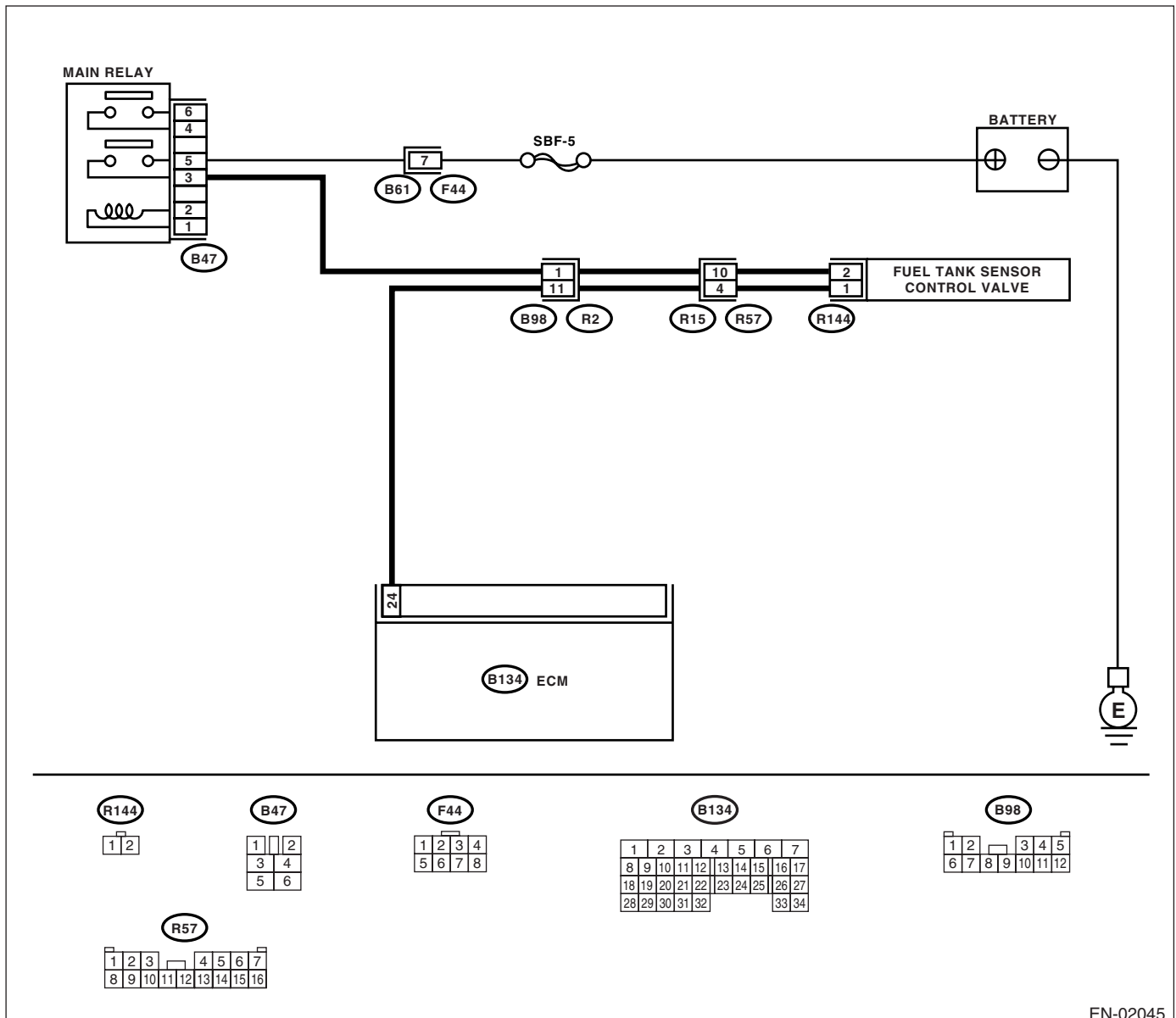

EN-02045

DIAGNOSTIC PROCEDURE WITH DIAGNOSTIC TROUBLE CODE (DTC)

ENGINE (DIAGNOSTICS)

Step	Check	Yes	No
1 CHECK OUTPUT SIGNAL FROM ECM. 1) Turn ignition switch to ON. 2) Measure the voltage between ECM and chassis ground. Connector & terminal (B134) No. 24 (+) — Chassis ground (-):	Is the voltage more than 10 V?	Go to step 3.	Go to step 2.
2 CHECK FOR POOR CONTACT. Check for poor contact in ECM connector.	Is there poor contact in ECM connector?	Repair poor contact in ECM connector.	Replace the ECM. <Ref. to FU(H4DOTC)-42, Engine Control Module (ECM).>
3 CHECK HARNESS BETWEEN FUEL TANK SENSOR CONTROL VALVE AND ECM CONNECTOR. 1) Turn ignition switch to OFF. 2) Disconnect the connector from fuel tank sensor control valve. 3) Turn ignition switch to ON. 4) Measure the voltage between ECM and chassis ground. Connector & terminal (B134) No. 24 (+) — Chassis ground (-):	Is the voltage more than 10 V?	Repair short circuit to battery in harness between ECM and fuel tank sensor control valve connector. After repair, replace the ECM. <Ref. to FU(H4DOTC)-42, Engine Control Module (ECM).>	Go to step 4.
4 CHECK FUEL TANK SENSOR CONTROL VALVE. 1) Turn ignition switch to OFF. 2) Measure the resistance between fuel tank sensor control valve terminals. Terminals No. 1 — No. 2:	Is the resistance less than 1 Ω ?	Replace the fuel tank sensor control valve <Ref. to EC(H4DOTC)-12, Fuel Tank Sensor Control Valve.> and the ECM <Ref. to FU(H4DOTC)-42, Engine Control Module (ECM).>.	Go to step 5.
5 CHECK FOR POOR CONTACT. Check for poor contact in ECM connector.	Is there poor contact in ECM connector?	Repair poor contact in ECM connector.	Replace the ECM. <Ref. to FU(H4DOTC)-42, Engine Control Module (ECM).>

DIAGNOSTIC PROCEDURE WITH DIAGNOSTIC TROUBLE CODE (DTC)

ENGINE (DIAGNOSTICS)

DF:DTC P1448 — FUEL TANK SENSOR CONTROL VALVE RANGE/PERFORMANCE —

DTC DETECTING CONDITION:

- Two consecutive driving cycles with fault
- GENERAL DESCRIPTION <Ref. to GD(H4DOTC)-239, DTC P1448 — FUEL TANK SENSOR CONTROL VALVE RANGE PERFORMANCE —, Diagnostic Trouble Code (DTC) Detecting Criteria.>

CAUTION:

After repair or replacement of faulty parts, conduct Clear Memory Mode <Ref. to EN(H4DOTC)-44, OPERATION, Clear Memory Mode.> and Inspection Mode <Ref. to EN(H4DOTC)-36, OPERATION, Inspection Mode.>.

WIRING DIAGRAM:

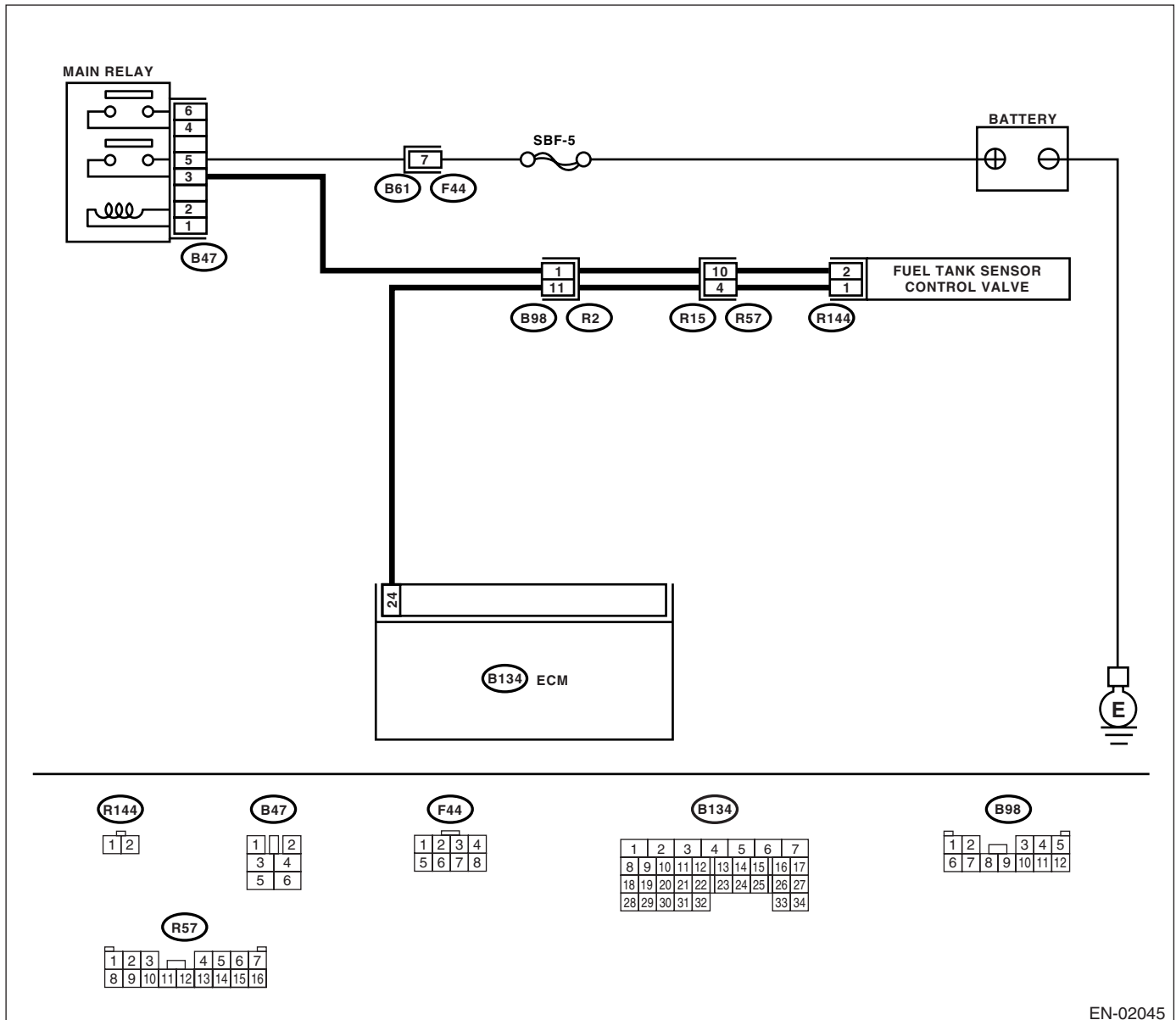

EN-02045

DIAGNOSTIC PROCEDURE WITH DIAGNOSTIC TROUBLE CODE (DTC)

ENGINE (DIAGNOSTICS)

	Step	Check	Yes	No
1	CHECK FOR OTHER DTC ON DISPLAY.	Is any other DTC displayed?	Inspect the relevant DTC using the "List of Diagnostic Trouble Codes (DTC)". <Ref. to EN(H4DOTC)-68, List of Diagnostic Trouble Code (DTC).>	Go to step 2.
2	CHECK FUEL FILLER CAP. 1) Turn ignition switch to OFF. 2) Open the fuel flap.	Is the fuel filler cap tightened securely?	Go to step 3.	Tighten fuel filler cap securely.
3	CHECK EVAPORATIVE EMISSION LINE. NOTE: Check the following items. <ul style="list-style-type: none">• Disconnection, leakage and clogging of hoses between fuel tank pressure sensor and fuel tank.• Disconnection, leakage and clogging of hoses and pipes between fuel filler pipe and fuel tank.	Is there any trouble in evaporative emission line?	Repair the hoses and pipes.	Replace the fuel tank pressure sensor.

DIAGNOSTIC PROCEDURE WITH DIAGNOSTIC TROUBLE CODE (DTC)

ENGINE (DIAGNOSTICS)

DG:DTC P1491 — POSITIVE CRANKCASE VENTILATION (BLOW-BY) FUNCTION PROBLEM —

DTC DETECTING CONDITION:

- Two consecutive driving cycles with fault
- GENERAL DESCRIPTION <Ref. to GD(H4DOTC)-243, DTC P1491 — POSITIVE CRANKCASE VENTILATION (BLOW-BY) FUNCTION PROBLEM —, Diagnostic Trouble Code (DTC) Detecting Criteria.>

TROUBLE SYMPTOM:

Erroneous idling

CAUTION:

After repair or replacement of faulty parts, conduct Clear Memory Mode <Ref. to EN(H4DOTC)-44, OPERATION, Clear Memory Mode.> and Inspection Mode <Ref. to EN(H4DOTC)-36, OPERATION, Inspection Mode.>.

WIRING DIAGRAM:

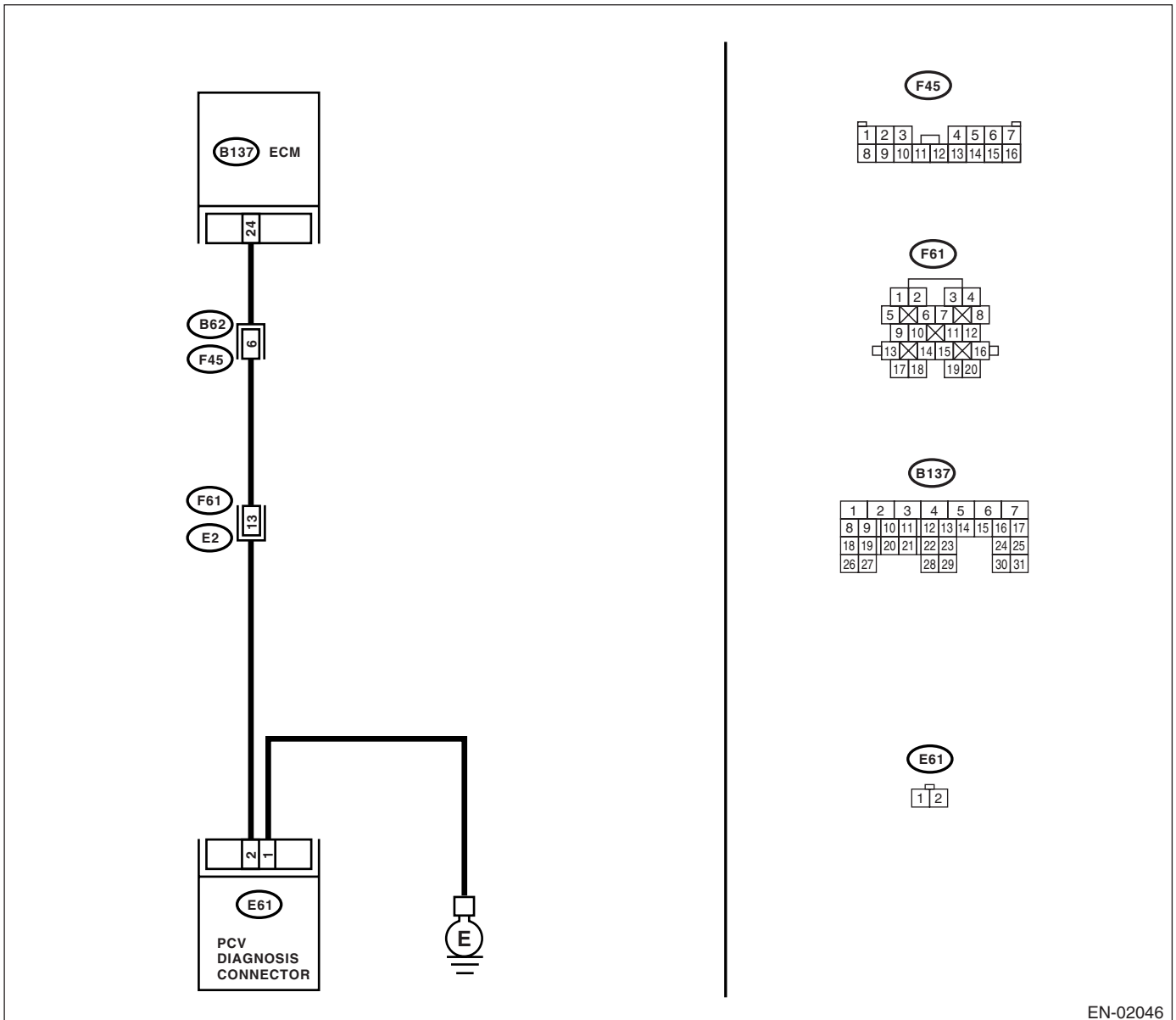

EN-02046

DIAGNOSTIC PROCEDURE WITH DIAGNOSTIC TROUBLE CODE (DTC)

ENGINE (DIAGNOSTICS)

Step	Check	Yes	No
1 CHECK BLOW-BY HOSE. Check the blow-by hose.	Is there disconnection or crack in blow-by hose?	Replace or repair blow-by hose.	Go to step 2.
2 INSPECT HARNESS BETWEEN PCV DIAGNOSIS CONNECTOR AND ECM CONNECTOR. 1) Turn the ignition switch to OFF. 2) Disconnect the connector from PCV diagnosis connector and ECM. 3) Measure the resistance of harness between PCV diagnosis connector and ECM connector. <i>Connector & terminal</i> <i>(B137) No. 24 — (E61) No. 2:</i>	Is the resistance less than 1 Ω ?	Go to step 3.	Repair open circuit in harness between PCV diagnosis connector and ECM.
3 INSPECT HARNESS BETWEEN PCV DIAGNOSIS CONNECTOR AND ECM CONNECTOR. Measure the resistance of harness between PCV diagnosis connector and chassis ground. <i>Connector & terminal</i> <i>(B137) No. 24 — Chassis ground:</i>	Is the resistance more than 1 M Ω ?	Go to step 4.	Repair short circuit to chassis ground in harness between PCV diagnosis connector and ECM.
4 INSPECT PCV DIAGNOSIS CONNECTOR GROUND CIRCUIT. Measure the resistance between PCV diagnosis connector and engine ground. <i>Connector & terminal</i> <i>(B61) No. 1 — Engine ground:</i>	Is the resistance less than 5 Ω ?	Go to step 5.	Repair PCV diagnosis connector ground circuit.
5 INSPECT PCV DIAGNOSIS CONNECTOR. Measure the resistance between PCV diagnosis connector and terminal. <i>Terminals</i> <i>No. 1 — No. 2:</i>	Is the resistance less than 1 Ω ?	Repair poor contact in ECM and PCV diagnosis connector.	Replace PCV diagnosis connector.

DIAGNOSTIC PROCEDURE WITH DIAGNOSTIC TROUBLE CODE (DTC)

ENGINE (DIAGNOSTICS)

DH:DTC P1518 — STARTER SWITCH CIRCUIT LOW INPUT —

DTC DETECTING CONDITION:

- Two consecutive driving cycles with fault
- GENERAL DESCRIPTION <Ref. to GD(H4DOTC)-245, DTC P1518 — STARTER SWITCH CIRCUIT LOW INPUT —, Diagnostic Trouble Code (DTC) Detecting Criteria.>

TROUBLE SYMPTOM:

Failure of engine to start

CAUTION:

After repair or replacement of faulty parts, conduct Clear Memory Mode <Ref. to EN(H4DOTC)-44, OPERATION, Clear Memory Mode.> and Inspection Mode <Ref. to EN(H4DOTC)-36, OPERATION, Inspection Mode.>.

DIAGNOSTIC PROCEDURE WITH DIAGNOSTIC TROUBLE CODE (DTC)

ENGINE (DIAGNOSTICS)

WIRING DIAGRAM:

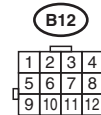
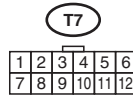
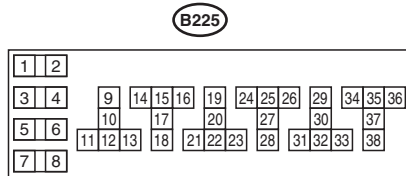
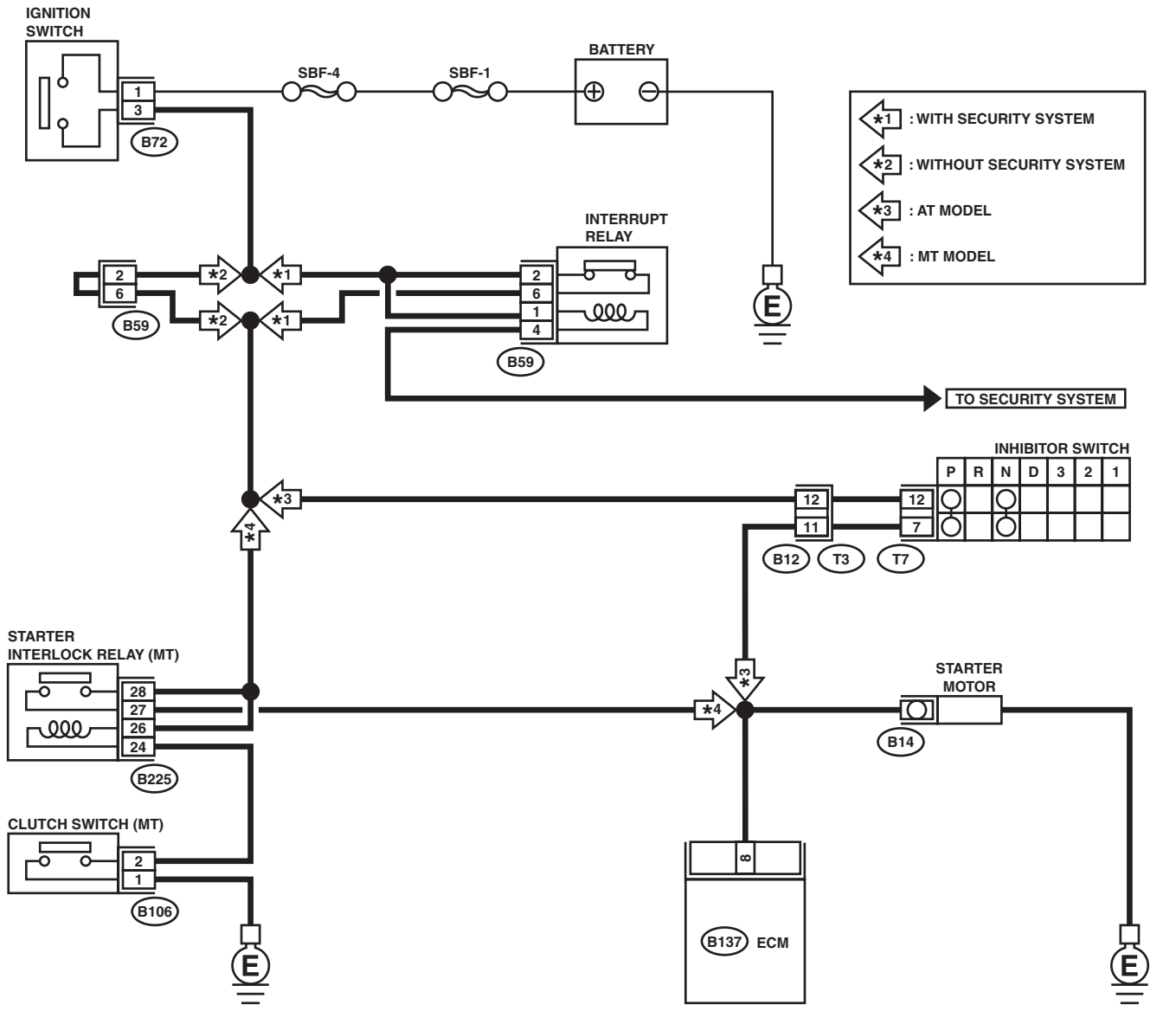

EN-02015

DIAGNOSTIC PROCEDURE WITH DIAGNOSTIC TROUBLE CODE (DTC)

ENGINE (DIAGNOSTICS)

Step	Check	Yes	No
1 CHECK OPERATION OF STARTER MOTOR.	Does the starter motor operate when ignition switch is turned to START?	Repair the harness and connector. NOTE: In this case, repair the following: <ul style="list-style-type: none">• Open or ground short circuit in harness between ECM and starter motor connector• Poor contact in ECM connector	Check the starter motor circuit. <Ref. to EN(H4DOTC)-57, STARTER MOTOR CIRCUIT, Diagnostics for Engine Starting Failure.>

DI: DTC P1544 — EXHAUST GAS TEMPERATURE TOO HIGH —

DTC DETECTING CONDITION:

- Immediately at fault recognition
- GENERAL DESCRIPTION<Ref. to GD(H4DOTC)-246, DTC P1544 — EXHAUST GAS TEMPERATURE TOO HIGH —, Diagnostic Trouble Code (DTC) Detecting Criteria.>

TROUBLE SYMPTOM:

- Erroneous idling
- Poor driving performance

CAUTION:

After repair or replacement of faulty parts, conduct Clear Memory Mode <Ref. to EN(H4DOTC)-44, OPERATION, Clear Memory Mode.> and Inspection Mode <Ref. to EN(H4DOTC)-36, OPERATION, Inspection Mode.>.

WIRING DIAGRAM:

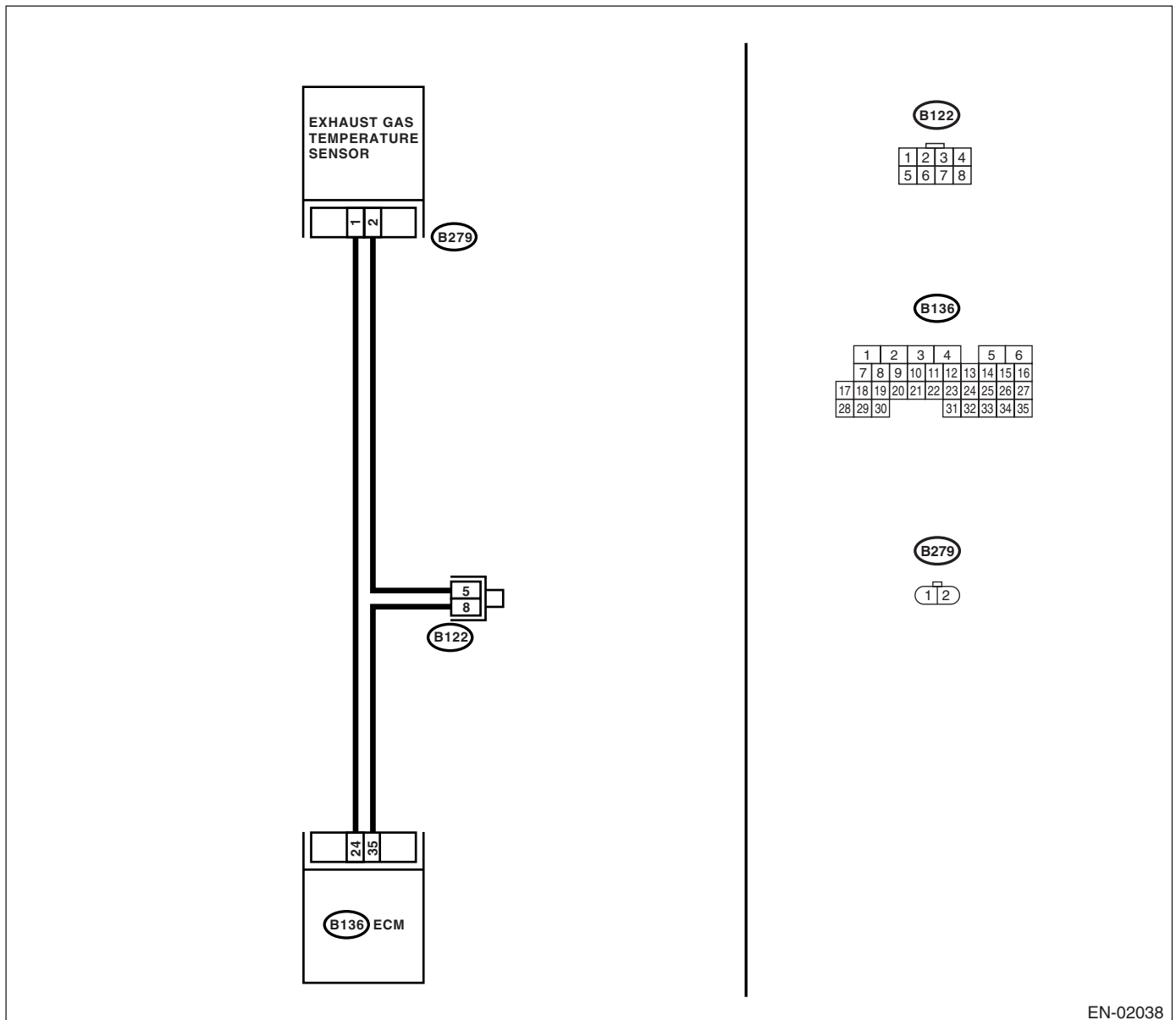

EN-02038

DIAGNOSTIC PROCEDURE WITH DIAGNOSTIC TROUBLE CODE (DTC)

ENGINE (DIAGNOSTICS)

Step	Check	Yes	No
1	CHECK ANY OTHER DTC ON DISPLAY.	Is any other DTC displayed?	Inspect the relevant DTC using "List of Diagnostic Trouble Code (DTC)". <Ref. to EN(H4DOTC)-68, List of Diagnostic Trouble Code (DTC).> NOTE: In this case, it is not necessary to inspect DTC P1544.
2	CHECK EXHAUST SYSTEM. Check the exhaust system parts. NOTE: Check the following items. <ul style="list-style-type: none"> • Loose installation of exhaust manifold • Cracks or hole of exhaust manifold • Loose installation of front oxygen (A/F) sensor 	Is there a fault in exhaust system?	Repair or replace the failure, then replace pre-catalytic converter. Contact your SOA Service Center. NOTE: Inspection by DTM is required, because probable cause is deterioration of multiple parts.

DJ:DTC P1560 — BACK-UP VOLTAGE CIRCUIT MALFUNCTION —

DTC DETECTING CONDITION:

- Immediately at fault recognition
- GENERAL DESCRIPTION <Ref. to GD(H4DOTC)-247, DTC P1560 — BACK-UP VOLTAGE CIRCUIT MALFUNCTION —, Diagnostic Trouble Code (DTC) Detecting Criteria.>

CAUTION:

After repair or replacement of faulty parts, conduct Clear Memory Mode <Ref. to EN(H4DOTC)-44, OPERATION, Clear Memory Mode.> and Inspection Mode <Ref. to EN(H4DOTC)-36, OPERATION, Inspection Mode.>.

DIAGNOSTIC PROCEDURE WITH DIAGNOSTIC TROUBLE CODE (DTC)

ENGINE (DIAGNOSTICS)

WIRING DIAGRAM:

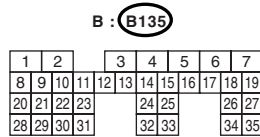
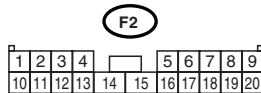
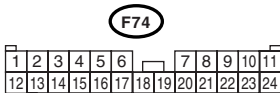
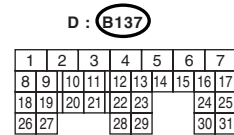
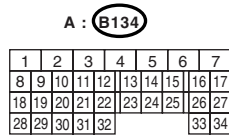
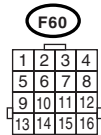
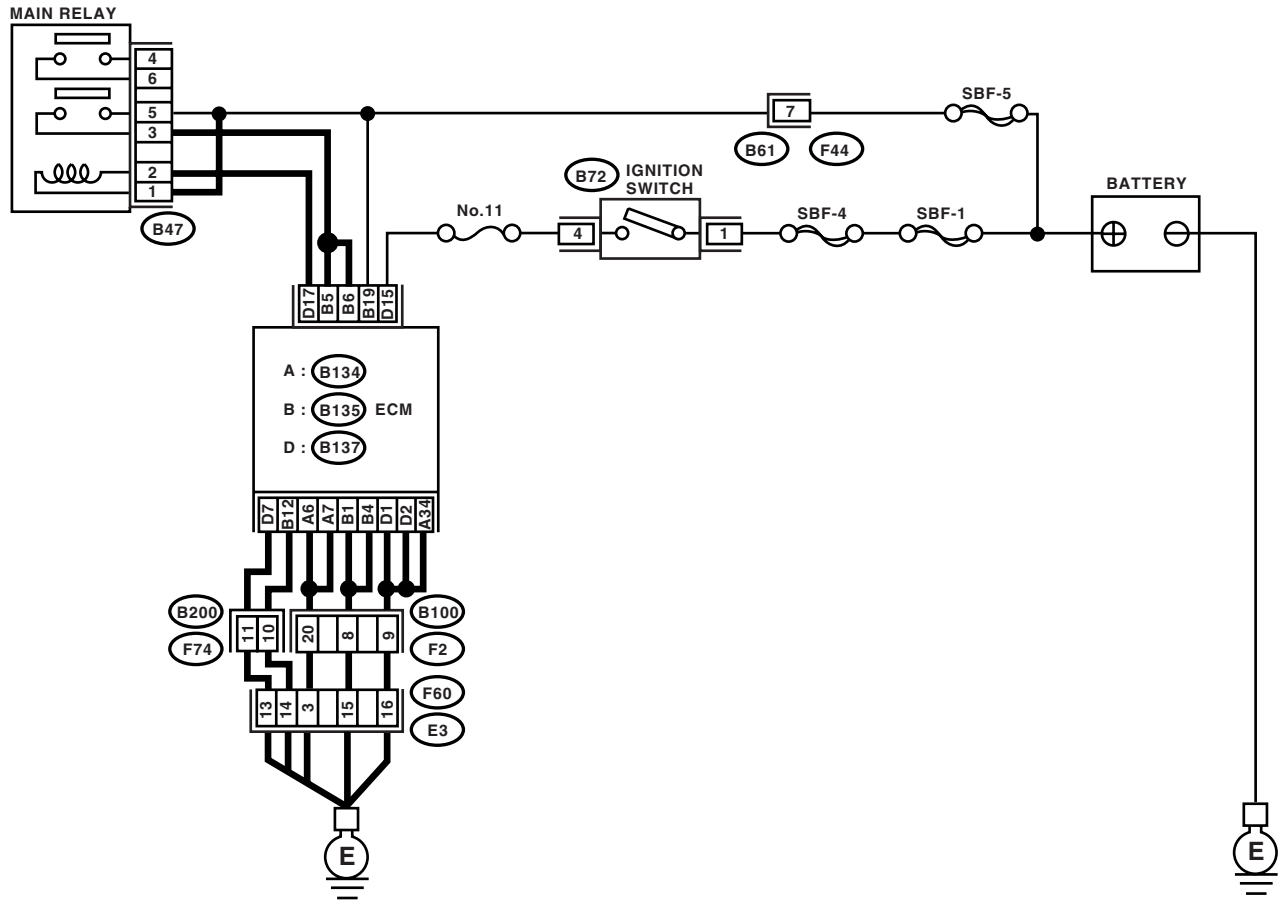

EN-02016

DIAGNOSTIC PROCEDURE WITH DIAGNOSTIC TROUBLE CODE (DTC)

ENGINE (DIAGNOSTICS)

Step	Check	Yes	No
1 CHECK INPUT SIGNAL FOR ECM. 1) Turn the ignition switch to OFF. 2) Measure the voltage between ECM and chassis ground. Connector & terminal (B135) No. 19 (+) — Chassis ground (-):	Is the voltage more than 10 V?	Repair the poor contact in ECM connector.	Go to step 2.
2 CHECK HARNESS BETWEEN ECM AND MAIN FUSE BOX CONNECTOR. 1) Disconnect the connector from ECM. 2) Measure the resistance of harness between ECM and chassis ground. Connector & terminal (B135) No. 19 — Chassis ground:	Is the resistance less than 10 Ω ?	Repair the ground short circuit in harness between ECM connector and battery terminal.	Go to step 3.
3 CHECK FUSE SBF-5.	Is the fuse blown?	Replace the fuse.	Repair the harness and connector. NOTE: In this case, repair the following: <ul style="list-style-type: none">• Open circuit in harness between ECM and battery• Poor contact in ECM connector• Poor contact in battery terminal

DIAGNOSTIC PROCEDURE WITH DIAGNOSTIC TROUBLE CODE (DTC)

ENGINE (DIAGNOSTICS)

DK:DTC P2088 — OCV SOLENOID VALVE SIGNAL A CIRCUIT OPEN (BANK 1)

DTC DETECTING CONDITION:

- Two consecutive driving cycles with fault
- GENERAL DESCRIPTION <Ref. to GD(H4DOTC)-248, DTC P2088 — OCV SOLENOID VALVE SIGNAL A CIRCUIT OPEN (BANK 1) —, Diagnostic Trouble Code (DTC) Detecting Criteria.>

TROUBLE SYMPTOM:

Erroneous idling

CAUTION:

After repair or replacement of faulty parts, conduct Clear Memory Mode <Ref. to EN(H4DOTC)-44, OPERATION, Clear Memory Mode.> and Inspection Mode <Ref. to EN(H4DOTC)-36, OPERATION, Inspection Mode.>.

WIRING DIAGRAM:

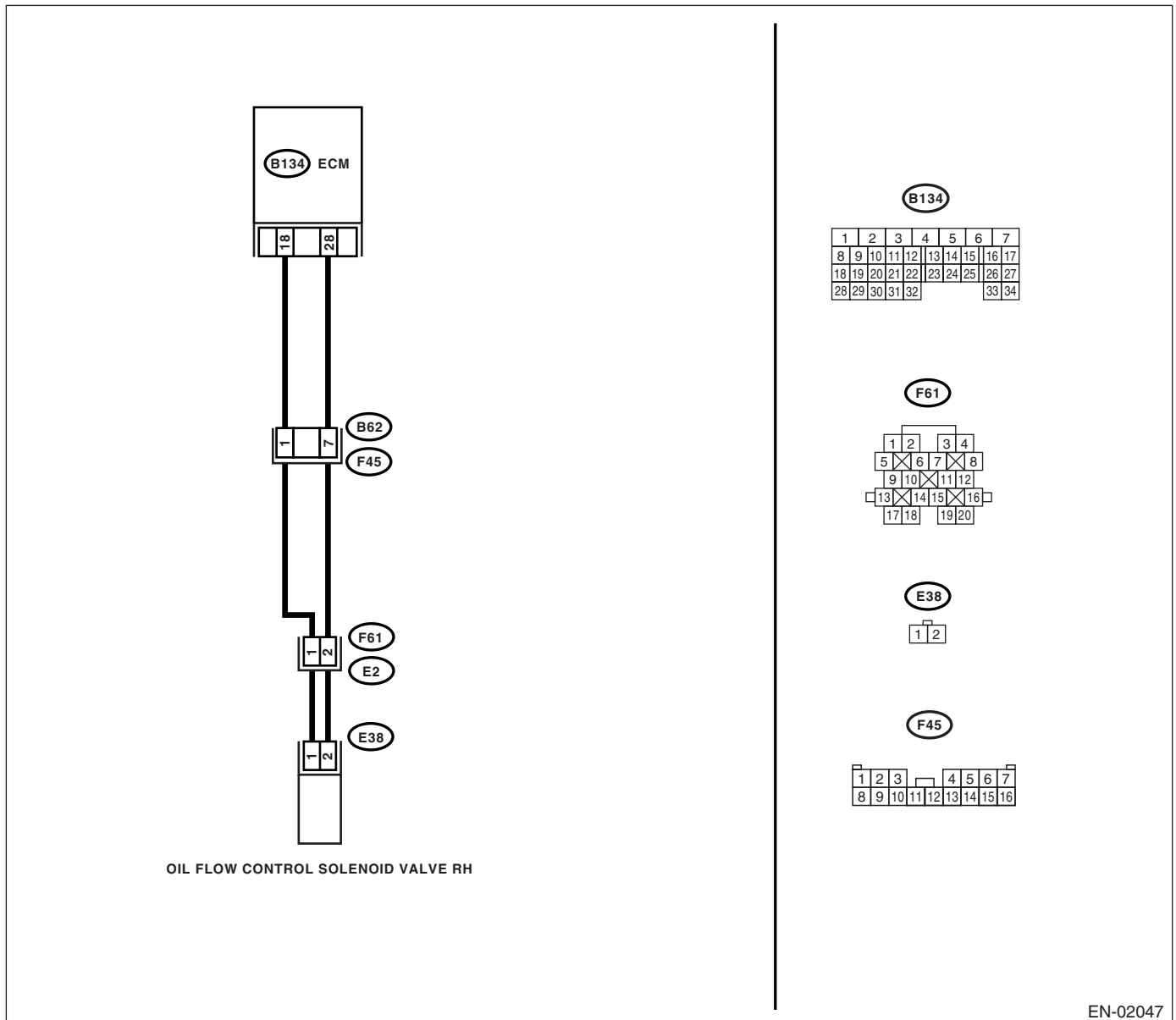

EN-02047

DIAGNOSTIC PROCEDURE WITH DIAGNOSTIC TROUBLE CODE (DTC)

ENGINE (DIAGNOSTICS)

Step	Check	Yes	No
<p>1</p> <p>CHECK HARNESS BETWEEN ECM AND OIL FLOW CONTROL SOLENOID VALVE.</p> <p>1) Turn the ignition switch to OFF. 2) Disconnect the connector from ECM and oil flow control solenoid valve. 3) Measure the resistance between ECM and oil flow control solenoid valve.</p> <p>Connector & terminal (B134) No. 18 — (E38) No. 1: (B134) No. 28 — (E38) No. 2:</p>	<p>Is the resistance less than 1 Ω?</p>	<p>Go to step 2.</p>	<p>Repair the open circuit in harness between ECM and oil flow control solenoid valve connector.</p> <p>NOTE: In this case, repair the following:</p> <ul style="list-style-type: none"> • Open circuit in harness between ECM and oil flow control solenoid valve connector • Poor contact in coupling connector.
<p>2</p> <p>CHECK HARNESS BETWEEN ECM AND OIL FLOW CONTROL SOLENOID VALVE.</p> <p>Measure the resistance between ECM and oil flow control solenoid valve.</p> <p>Connector & terminal (E38) No. 1 — Engine ground: (E38) No. 2 — Engine ground:</p>	<p>Is the resistance more than 1 MΩ?</p>	<p>Go to step 3.</p>	<p>Repair the short circuit between ECM and oil flow control solenoid valve connector.</p>
<p>3</p> <p>CHECK OIL FLOW CONTROL SOLENOID VALVE.</p> <p>1) Remove the oil flow control solenoid valve. 2) Measure the resistance between oil flow control solenoid valve terminal.</p> <p>Terminals No. 1 — No. 2:</p>	<p>Is the resistance 6 — 12 Ω?</p>	<p>Repair the poor contact in ECM and oil flow control solenoid valve.</p>	<p>Replace the oil flow control solenoid valve. <Ref. to ME(H4DOTC)-61, Camshaft.></p>

DIAGNOSTIC PROCEDURE WITH DIAGNOSTIC TROUBLE CODE (DTC)

ENGINE (DIAGNOSTICS)

DL:DTC P2089 — OCV SOLENOID VALVE SIGNAL A CIRCUIT SHORT (BANK 1)

DTC DETECTING CONDITION:

- Two consecutive driving cycles with fault
- GENERAL DESCRIPTION <Ref. to GD(H4DOTC)-250, DTC P2089 — OCV SOLENOID VALVE SIGNAL A CIRCUIT SHORT (BANK 1) —, Diagnostic Trouble Code (DTC) Detecting Criteria.>

TROUBLE SYMPTOM:

Erroneous idling

CAUTION:

After repair or replacement of faulty parts, conduct Clear Memory Mode <Ref. to EN(H4DOTC)-44, OPERATION, Clear Memory Mode.> and Inspection Mode <Ref. to EN(H4DOTC)-36, OPERATION, Inspection Mode.>.

WIRING DIAGRAM:

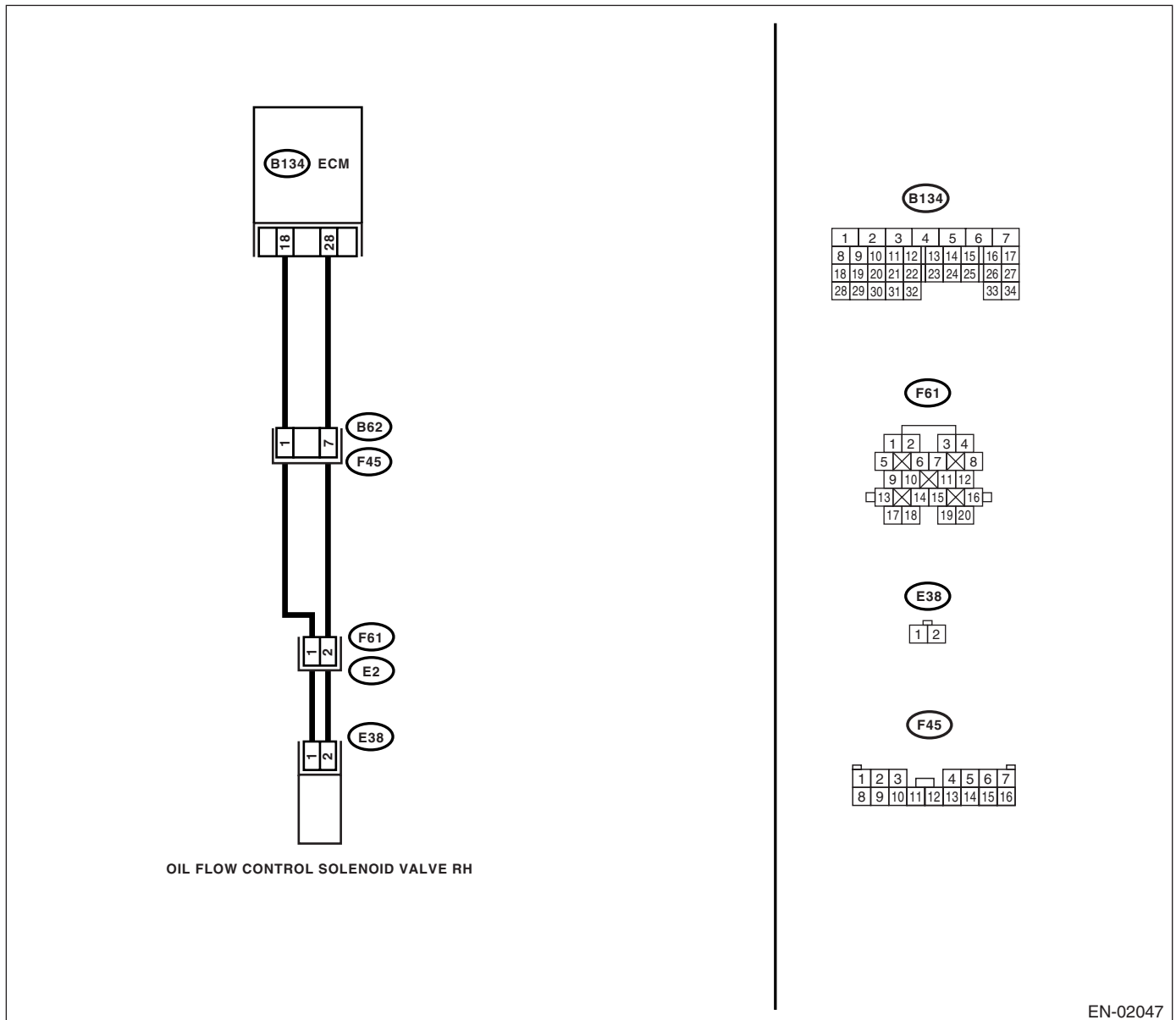

EN-02047

DIAGNOSTIC PROCEDURE WITH DIAGNOSTIC TROUBLE CODE (DTC)

ENGINE (DIAGNOSTICS)

Step	Check	Yes	No
<p>1</p> <p>CHECK HARNESS BETWEEN ECM AND OIL FLOW CONTROL SOLENOID VALVE.</p> <p>1) Turn the ignition switch to OFF. 2) Disconnect the connector from ECM and oil flow control solenoid valve. 3) Measure the resistance between ECM and oil flow control solenoid valve.</p> <p>Connector & terminal (B134) No. 18 — (E38) No. 1: (B134) No. 28 — (E38) No. 2:</p>	<p>Is the resistance less than 1 Ω?</p>	<p>Go to step 2.</p>	<p>Repair the open circuit in harness between ECM and oil flow control solenoid valve connector.</p> <p>NOTE: In this case, repair the following:</p> <ul style="list-style-type: none"> • Open circuit in harness between ECM and oil flow control solenoid valve connector • Poor contact in coupling connector.
<p>2</p> <p>CHECK HARNESS BETWEEN ECM AND OIL FLOW CONTROL SOLENOID VALVE.</p> <p>1) Turn the ignition switch to OFF. 2) Disconnect the connector from ECM and oil flow control solenoid valve. 3) Measure the resistance between ECM and oil flow control solenoid valve.</p> <p>Connector & terminal (E38) No. 1 — Engine ground: (E38) No. 2 — Engine ground:</p>	<p>Is the resistance more than 1 MΩ?</p>	<p>Go to step 3.</p>	<p>Repair the short circuit between ECM and oil flow control solenoid valve connector.</p>
<p>3</p> <p>CHECK OIL FLOW CONTROL SOLENOID VALVE.</p> <p>1) Remove the oil flow control solenoid valve. 2) Measure the resistance between oil flow control solenoid valve terminal.</p> <p>Terminals No. 1 — No. 2:</p>	<p>Is the resistance 6 — 12 Ω?</p>	<p>Repair the poor contact in ECM and oil flow control solenoid valve.</p>	<p>Replace the oil flow control solenoid valve. <Ref. to ME(H4DOTC)-61, Camshaft.></p>

DIAGNOSTIC PROCEDURE WITH DIAGNOSTIC TROUBLE CODE (DTC)

ENGINE (DIAGNOSTICS)

DM:DTC P2092 — OCV SOLENOID VALVE SIGNAL A CIRCUIT OPEN (BANK 2)

DTC DETECTING CONDITION:

- Two consecutive driving cycles with fault
- GENERAL DESCRIPTION <Ref. to GD(H4DOTC)-252, DTC P2092 — OCV SOLENOID VALVE SIGNAL A CIRCUIT OPEN (BANK 2) —, Diagnostic Trouble Code (DTC) Detecting Criteria.>

TROUBLE SYMPTOM:

Erroneous idling

CAUTION:

After repair or replacement of faulty parts, conduct Clear Memory Mode <Ref. to EN(H4DOTC)-44, OPERATION, Clear Memory Mode.> and Inspection Mode <Ref. to EN(H4DOTC)-36, OPERATION, Inspection Mode.>.

WIRING DIAGRAM:

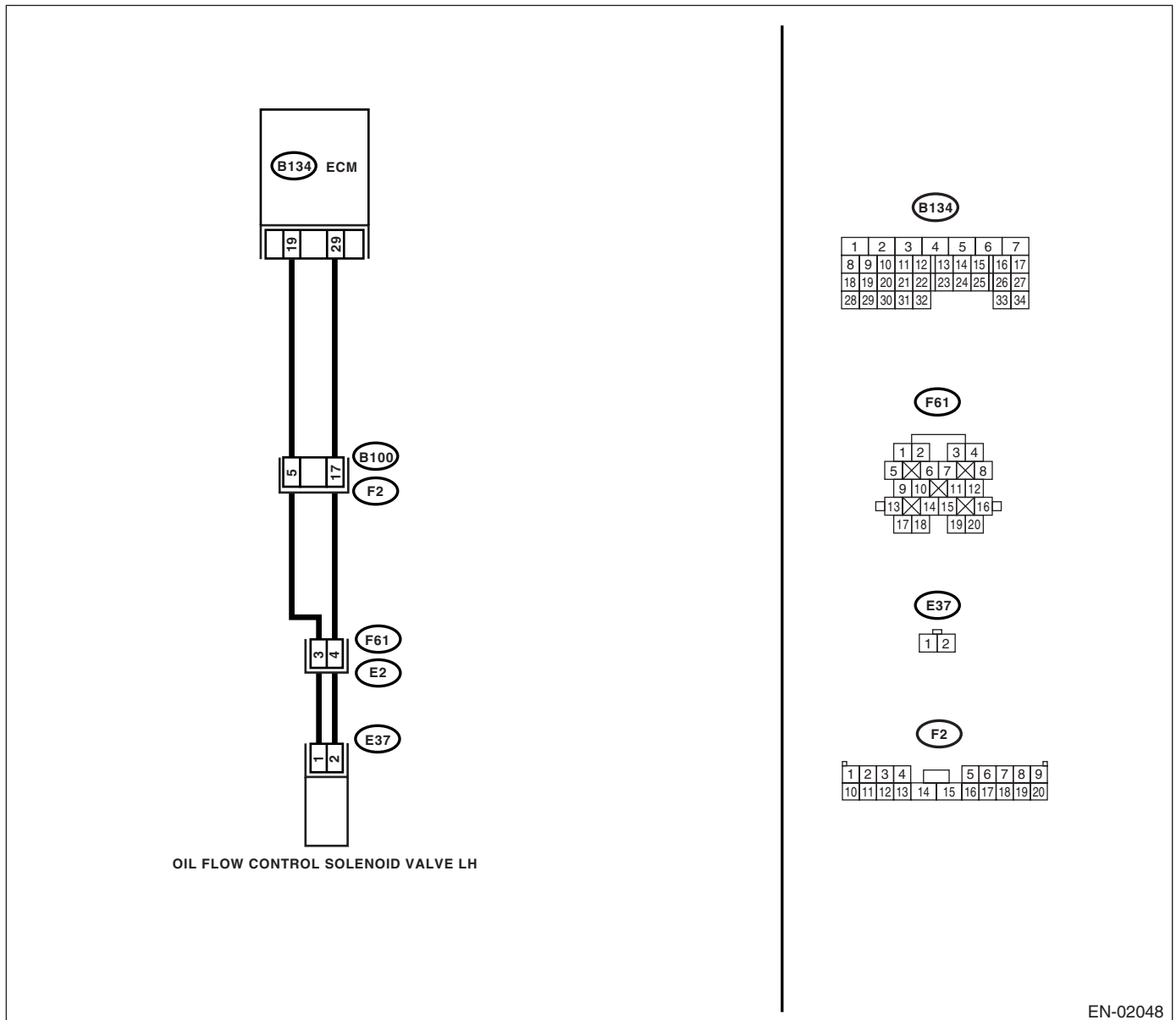

EN-02048

DIAGNOSTIC PROCEDURE WITH DIAGNOSTIC TROUBLE CODE (DTC)

ENGINE (DIAGNOSTICS)

Step	Check	Yes	No
<p>1</p> <p>CHECK HARNESS BETWEEN ECM AND OIL FLOW CONTROL SOLENOID VALVE.</p> <p>1) Turn the ignition switch to OFF. 2) Disconnect the connector from ECM and oil flow control solenoid valve. 3) Measure the resistance between ECM and oil flow control solenoid valve.</p> <p>Connector & terminal (B134) No. 19 — (E37) No. 1: (B134) No. 29 — (E37) No. 2:</p>	<p>Is the resistance less than 1 Ω?</p>	<p>Go to step 2.</p>	<p>Repair the open circuit in harness between ECM and oil flow control solenoid valve connector.</p> <p>NOTE: In this case, repair the following:</p> <ul style="list-style-type: none"> • Open circuit in harness between ECM and oil flow control solenoid valve connector • Poor contact in coupling connector.
<p>2</p> <p>CHECK HARNESS BETWEEN ECM AND OIL FLOW CONTROL SOLENOID VALVE.</p> <p>Measure the resistance between ECM and oil flow control solenoid valve.</p> <p>Connector & terminal (E37) No. 1 — Engine ground: (E37) No. 2 — Engine ground:</p>	<p>Is the resistance more than 1 MΩ?</p>	<p>Go to step 3.</p>	<p>Repair the short circuit between ECM and oil flow control solenoid valve connector.</p>
<p>3</p> <p>CHECK OIL FLOW CONTROL SOLENOID VALVE.</p> <p>1) Remove the oil flow control solenoid valve. 2) Measure the resistance between oil flow control solenoid valve terminal.</p> <p>Terminals No. 1 — No. 2:</p>	<p>Is the resistance 6 — 12 Ω?</p>	<p>Repair the poor contact in ECM and oil flow control solenoid valve.</p>	<p>Replace the oil flow control solenoid valve. <Ref. to ME(H4DOTC)-61, Camshaft.></p>

DIAGNOSTIC PROCEDURE WITH DIAGNOSTIC TROUBLE CODE (DTC)

ENGINE (DIAGNOSTICS)

DN:DTC P2093 — OCV SOLENOID VALVE SIGNAL A CIRCUIT SHORT (BANK 2)

DTC DETECTING CONDITION:

- Two consecutive driving cycles with fault
- GENERAL DESCRIPTION <Ref. to GD(H4DOTC)-254, DTC P2093 — OCV SOLENOID VALVE SIGNAL A CIRCUIT SHORT (BANK 2) —, Diagnostic Trouble Code (DTC) Detecting Criteria.>

TROUBLE SYMPTOM:

Erroneous idling

CAUTION:

After repair or replacement of faulty parts, conduct Clear Memory Mode <Ref. to EN(H4DOTC)-44, OPERATION, Clear Memory Mode.> and Inspection Mode <Ref. to EN(H4DOTC)-36, OPERATION, Inspection Mode.>.

WIRING DIAGRAM:

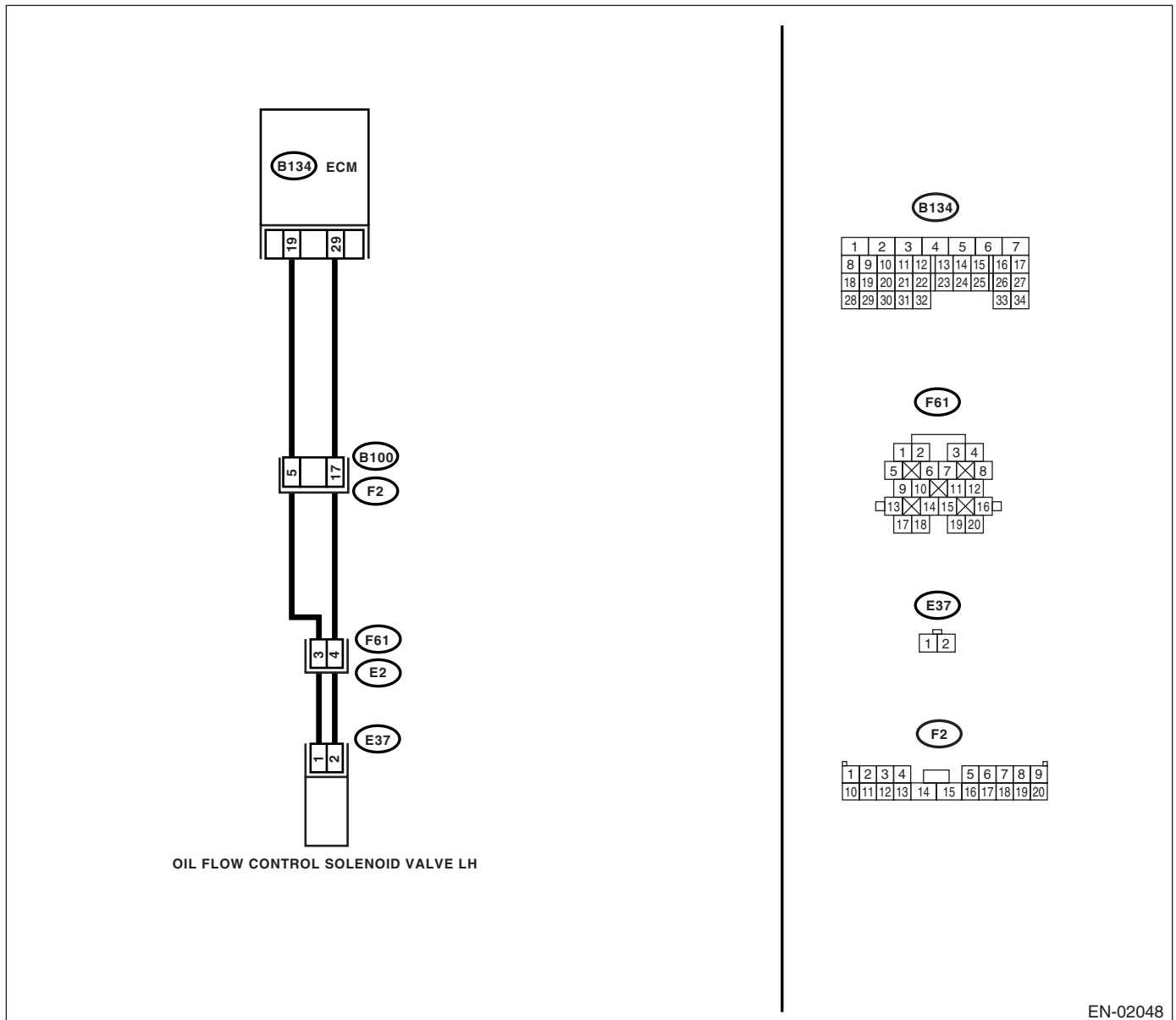

EN-02048

DIAGNOSTIC PROCEDURE WITH DIAGNOSTIC TROUBLE CODE (DTC)

ENGINE (DIAGNOSTICS)

Step	Check	Yes	No
<p>1</p> <p>CHECK HARNESS BETWEEN ECM AND OIL FLOW CONTROL SOLENOID VALVE.</p> <p>1) Turn the ignition switch to OFF. 2) Disconnect the connector from ECM and oil flow control solenoid valve. 3) Measure the resistance between ECM and oil flow control solenoid valve.</p> <p>Connector & terminal (B134) No. 19 — (E37) No. 1: (B134) No. 29 — (E37) No. 2:</p>	<p>Is the resistance less than 1 Ω?</p>	<p>Go to step 2.</p>	<p>Repair the open circuit in harness between ECM and oil flow control solenoid valve connector.</p> <p>NOTE: In this case, repair the following:</p> <ul style="list-style-type: none"> • Open circuit in harness between ECM and oil flow control solenoid valve connector • Poor contact in coupling connector.
<p>2</p> <p>CHECK HARNESS BETWEEN ECM AND OIL FLOW CONTROL SOLENOID VALVE.</p> <p>1) Turn the ignition switch to OFF. 2) Disconnect the connector from ECM and oil flow control solenoid valve. 3) Measure the resistance between ECM and oil flow control solenoid valve.</p> <p>Connector & terminal (E37) No. 1 — Engine ground: (E37) No. 2 — Engine ground:</p>	<p>Is the resistance more than 1 MΩ?</p>	<p>Go to step 3.</p>	<p>Repair the short circuit between ECM and oil flow control solenoid valve connector.</p>
<p>3</p> <p>CHECK OIL FLOW CONTROL SOLENOID VALVE.</p> <p>1) Remove the oil flow control solenoid valve. 2) Measure the resistance between oil flow control solenoid valve terminal.</p> <p>Terminals No. 1 — No. 2:</p>	<p>Is the resistance 6 — 12 Ω?</p>	<p>Repair the poor contact in ECM and oil flow control solenoid valve.</p>	<p>Replace the oil flow control solenoid valve. <Ref. to ME(H4DOTC)-61, Camshaft.></p>

DIAGNOSTIC PROCEDURE WITH DIAGNOSTIC TROUBLE CODE (DTC)

ENGINE (DIAGNOSTICS)

DO:DTC P2096 — POST CATALYST FUEL TRIM SYSTEM TOO LEAN BANK 1 — DTC DETECTING CONDITION:

- Two consecutive driving cycles with fault
- GENERAL DESCRIPTION <Ref. to GD(H4DOTC)-256, DTC P2096 — POST CATALYST FUEL TRIM SYSTEM TOO LEAN BANK 1 —, Diagnostic Trouble Code (DTC) Detecting Criteria.>

CAUTION:

After repair or replacement of faulty parts, conduct Clear Memory Mode <Ref. to EN(H4DOTC)-44, OPERATION, Clear Memory Mode.> and Inspection Mode <Ref. to EN(H4DOTC)-36, OPERATION, Inspection Mode.>.

WIRING DIAGRAM:

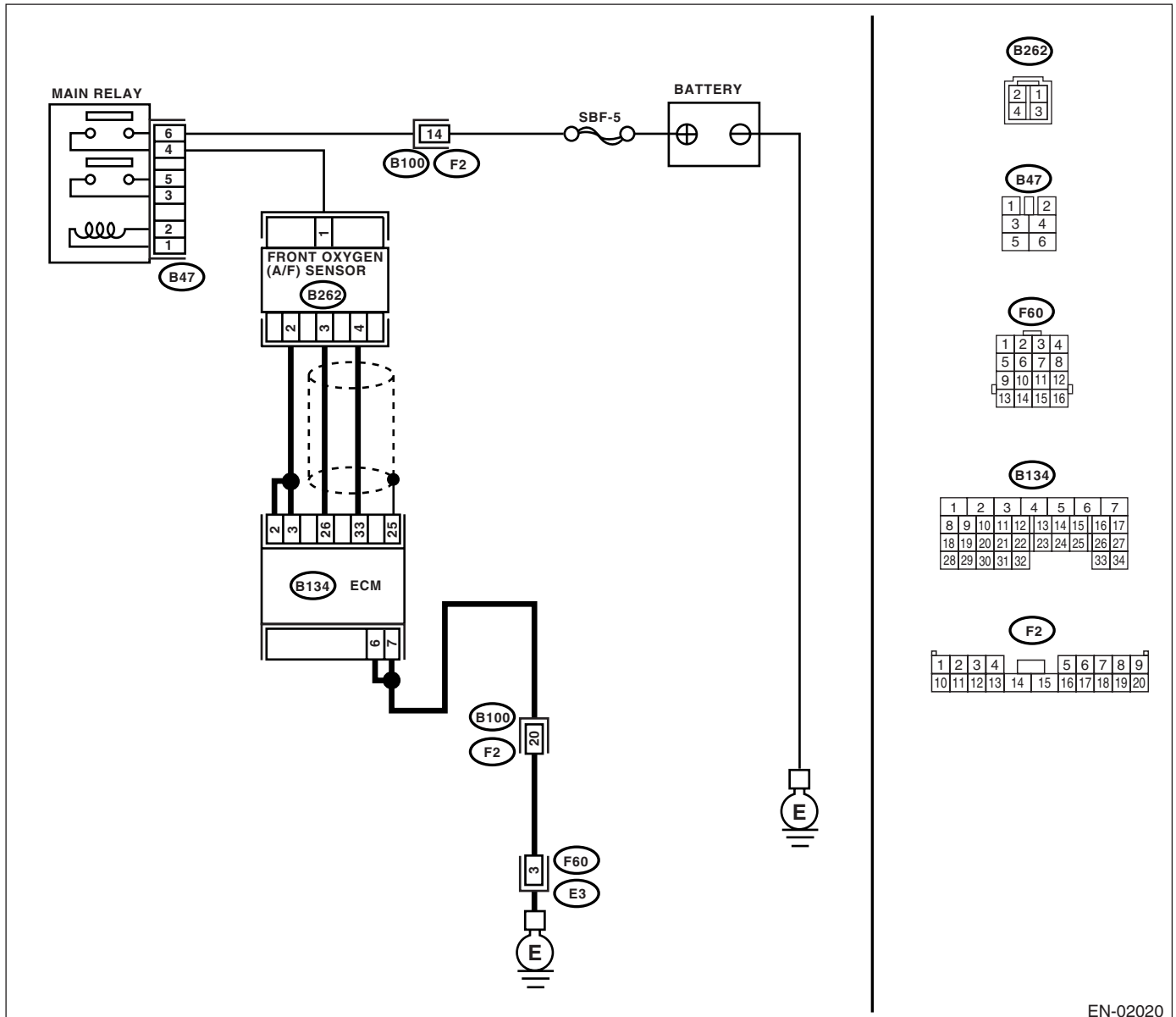

EN-02020

DIAGNOSTIC PROCEDURE WITH DIAGNOSTIC TROUBLE CODE (DTC)

ENGINE (DIAGNOSTICS)

Step	Check	Yes	No
1 CHECK ANY OTHER DTC ON DISPLAY.	Is any other DTC displayed?	Inspect the relevant DTC using "List of Diagnostic Trouble Code (DTC)". <Ref. to EN(H4DOTC)-68, List of Diagnostic Trouble Code (DTC).>	Go to step 2.
2 CHECK FRONT (A/F) OXYGEN SENSOR DATA. 1) Start engine. 2) While observing the Subaru Select Monitor or OBD-II general scan tool screen, warm-up the engine until coolant temperature is above 75°C (167°F). If the engine is already warmed-up, operate at idle speed for at least 1 minute. 3) Read data of front oxygen (A/F) sensor signal using Subaru Select Monitor or OBD-II general scan tool. NOTE: • Subaru Select Monitor For detailed operation procedure, refer to the "READ CURRENT DATA FOR ENGINE". <Ref. to EN(H4DOTC)-29, Subaru Select Monitor.> • OBD-II general scan tool For detailed operation procedures, refer to the OBD-II General Scan Tool Instruction Manual.	Is the measured value within 0.86 — 1.15 at idle?	Go to step 3.	Go to step 4.
3 CHECK REAR OXYGEN SENSOR SIGNAL. 1) Race engine at speeds from idling to 5,000 rpm for a total of 5 cycles. NOTE: To increase engine speed to 5,000 rpm, slowly depress accelerator pedal, taking approximately 5 seconds, and quickly release accelerator pedal to decrease engine speed. 2) Operate the LED operation mode for engine. NOTE: • Subaru Select Monitor For detailed operation procedure, refer to the "LED OPERATION MODE FOR ENGINE". <Ref. to EN(H4DOTC)-29, Subaru Select Monitor.>	Does the LED of {Rear O ₂ Rich Signal} blink?	Check front oxygen (A/F) sensor circuit.	Check rear oxygen sensor circuit. <Ref. to FU(H4DOTC)-39, Rear Oxygen Sensor.>
4 CHECK EXHAUST SYSTEM. Check exhaust system parts. NOTE: Check the following items. <ul style="list-style-type: none"> • Loose installation of portions • Damage (crack, hole etc.) of parts • Looseness of front oxygen (A/F) sensor • Looseness and ill fitting of parts between front oxygen (A/F) sensor and rear oxygen sensor 	Is there a fault in exhaust system?	Repair or replace faulty parts.	Go to step 5.
5 CHECK AIR INTAKE SYSTEM.	Are there holes, loose bolts or disconnection of hose on air intake system?	Repair the air intake system.	Go to step 6.

DIAGNOSTIC PROCEDURE WITH DIAGNOSTIC TROUBLE CODE (DTC)

ENGINE (DIAGNOSTICS)

Step	Check	Yes	No
<p>6 CHECK FUEL PRESSURE.</p> <p>Warning:</p> <ul style="list-style-type: none"> • Place “NO FIRE” signs near the working area. • Be careful not to spill fuel on the floor. <ol style="list-style-type: none"> 1) Release the fuel pressure. <ol style="list-style-type: none"> (1) Disconnect the connector from fuel pump relay. (2) Start the engine and run it until it stalls. (3) After the engine stalls, crank it for 5 more seconds. (4) Turn the ignition switch to OFF. 2) Connect the connector to fuel pump relay. 3) Disconnect the fuel delivery hose from fuel filter, and connect fuel pressure gauge. 4) Install the fuel filler cap. 5) Start the engine and idle while gear position is neutral. 6) Measure the fuel pressure while disconnecting pressure regulator vacuum hose from intake manifold. <p>Warning: Before removing the fuel pressure gauge, release fuel pressure.</p> <p>NOTE: If the fuel pressure does not increase, squeeze fuel return hose 2 to 3 times, then measure fuel pressure again.</p>	<p>Is the measured value 284 — 314 kPa (2.9 — 3.2 kg/cm², 41 — 46 psi)?</p>	<p>Go to step 7.</p>	<p>Repair the following items.</p> <p>Fuel pressure too high:</p> <ul style="list-style-type: none"> • Clogged fuel return line or bent hose <p>Fuel pressure too low:</p> <ul style="list-style-type: none"> • Improper fuel pump discharge • Clogged fuel supply line
<p>7 CHECK FUEL PRESSURE.</p> <p>After connecting the pressure regulator vacuum hose, measure fuel pressure.</p> <p>Warning: Before removing the fuel pressure gauge, release fuel pressure.</p> <p>NOTE:</p> <ul style="list-style-type: none"> • If the fuel pressure does not increase, squeeze fuel return hose 2 to 3 times, then measure fuel pressure again. • If out of specification as measured at this step, check or replace the pressure regulator and pressure regulator vacuum hose. 	<p>Is the measured value 206 — 235 kPa (2.1 — 2.4 kg/cm², 30 — 34 psi)?</p>	<p>Go to step 8.</p>	<p>Repair the following items.</p> <p>Fuel pressure too high:</p> <ul style="list-style-type: none"> • Faulty pressure regulator • Clogged fuel return line or bent hose <p>Fuel pressure too low:</p> <ul style="list-style-type: none"> • Faulty pressure regulator • Improper fuel pump discharge • Clogged fuel supply line
<p>8 CHECK ENGINE COOLANT TEMPERATURE SENSOR.</p> <ol style="list-style-type: none"> 1) Start the engine and warm-up completely. 2) Read the data of engine coolant temperature sensor signal using Subaru Select Monitor or OBD-II general scan tool. <p>NOTE:</p> <ul style="list-style-type: none"> • Subaru Select Monitor <p>For detailed operation procedure, refer to the “READ CURRENT DATA FOR ENGINE”. <Ref. to EN(H4DOTC)-29, Subaru Select Monitor.></p> <ul style="list-style-type: none"> • OBD-II general scan tool <p>For detailed operation procedures, refer to the OBD-II General Scan Tool Instruction Manual.</p>	<p>Is the temperature more than 60°C (140°F)?</p>	<p>Go to step 9.</p>	<p>Replace the engine coolant temperature sensor. <Ref. to FU(H4DOTC)-26, Engine Coolant Temperature Sensor.></p>

DIAGNOSTIC PROCEDURE WITH DIAGNOSTIC TROUBLE CODE (DTC)

ENGINE (DIAGNOSTICS)

Step	Check	Yes	No
<p>9</p> <p>CHECK MASS AIR FLOW AND INTAKE AIR TEMPERATURE.</p> <ol style="list-style-type: none"> 1) Start the engine and warm-up engine until coolant temperature is greater than 60°C (140°F). 2) Place the shift lever in neutral position. 3) Turn the A/C switch to OFF. 4) Turn all accessory switches to OFF. 5) Read the data of mass air flow and intake air temperature sensor signal using Subaru Select Monitor or OBD-II general scan tool. <p>NOTE:</p> <ul style="list-style-type: none"> • Subaru Select Monitor <p>For detailed operation procedure, refer to the "READ CURRENT DATA FOR ENGINE". <Ref. to EN(H4DOTC)-29, Subaru Select Monitor.></p> <ul style="list-style-type: none"> • OBD-II general scan tool <p>For detailed operation procedure, refer to the OBD-II General Scan Tool Instruction Manual.</p>	<p>Is the measured value within the followings? Ignition ON: 73.3 — 106.6 kPa (550 — 800 mmHg, 21.65 — 31.50 inHg) Idling: 24.0 — 41.3 kPa (180 — 310 mmHg, 7.09 — 12.20 inHg)</p>	Go to step 10.	Replace the mass air flow and intake air temperature sensor. <Ref. to FU(H4DOTC)-30, Mass Air Flow and Intake Air Temperature Sensor.>
<p>10</p> <p>CHECK MASS AIR FLOW AND INTAKE AIR TEMPERATURE SENSOR.</p> <ol style="list-style-type: none"> 1) Start the engine and warm-up engine until coolant temperature is greater than 60°C (140°F). 2) Place the shift lever in neutral position. 3) Turn the A/C switch to OFF. 4) Turn all accessory switches to OFF. 5) Open the front hood. 6) Measure the ambient temperature. 7) Read the data of mass air flow and intake air temperature sensor signal using Subaru Select Monitor or OBD-II general scan tool. <p>NOTE:</p> <ul style="list-style-type: none"> • Subaru Select Monitor <p>For detailed operation procedure, refer to the "READ CURRENT DATA FOR ENGINE". <Ref. to EN(H4DOTC)-29, Subaru Select Monitor.></p> <ul style="list-style-type: none"> • OBD-II general scan tool <p>For detailed operation procedure, refer to the OBD-II General Scan Tool Instruction Manual.</p>	<p>Subtract ambient temperature from intake air temperature. Is the obtained value -10 — 50°C (14 — 122°F)?</p>	Go to step 11.	Check the mass air flow and intake air temperature sensor. <Ref. to FU(H4DOTC)-30, Mass Air Flow and Intake Air Temperature Sensor.>
<p>11</p> <p>CHECK HARNESS BETWEEN ECM AND FRONT OXYGEN (A/F) SENSOR CONNECTOR.</p> <ol style="list-style-type: none"> 1) Turn the ignition switch to OFF. 2) Disconnect the connectors from ECM and front oxygen (A/F) sensor connector. 3) Measure the resistance of harness between ECM and front oxygen (A/F) sensor connector. <p>Connector & terminal (B134) No. 26 — Chassis ground: (B134) No. 33 — Chassis ground:</p>	<p>Is the resistance more than 1 MΩ?</p>	Go to step 12.	Repair ground short circuit in harness between ECM and front oxygen (A/F) sensor connector.

DIAGNOSTIC PROCEDURE WITH DIAGNOSTIC TROUBLE CODE (DTC)

ENGINE (DIAGNOSTICS)

Step	Check	Yes	No
<p>12 CHECK HARNESS BETWEEN ECM AND FRONT OXYGEN (A/F) SENSOR CONNECTOR.</p> <p>1) Turn the ignition switch to OFF. 2) Disconnect the connectors from front oxygen (A/F) sensor. 3) Measure the voltage of harness between ECM connector and chassis ground.</p> <p>Connector & terminal (B134) No. 26 (+) — Chassis ground (-): (B134) No. 33 (+) — Chassis ground (-):</p>	<p>Is the voltage more than 8 V?</p>	<p>Go to step 13.</p>	<p>Repair battery short circuit in harness between ECM and front oxygen (A/F) sensor connector.</p>
<p>13 CHECK HARNESS BETWEEN ECM AND FRONT OXYGEN (A/F) SENSOR CONNECTOR.</p> <p>1) Turn the ignition switch to OFF. 2) Disconnect the connectors from ECM and front oxygen (A/F) sensor connector. 3) Measure the resistance of harness between ECM and front oxygen (A/F) sensor connector.</p> <p>Connector & terminal (B134) No. 26 — (B262) No. 3: (B134) No. 33 — (B262) No. 4:</p>	<p>Is the resistance less than 1 Ω?</p>	<p>Replace the front oxygen (A/F) sensor. <Ref. to FU(H4DOTC)-37, Front Oxygen (A/F) Sensor.></p>	<p>Repair open circuit in harness between ECM and front oxygen (A/F) sensor connector.</p>

DIAGNOSTIC PROCEDURE WITH DIAGNOSTIC TROUBLE CODE (DTC)

ENGINE (DIAGNOSTICS)

DP:DTC P2097 — POST CATALYST FUEL TRIM SYSTEM TOO RICH BANK 1 — DTC DETECTING CONDITION:

- Two consecutive driving cycles with fault
- GENERAL DESCRIPTION <Ref. to GD(H4DOTC)-258, DTC P2097 — POST CATALYST FUEL TRIM SYSTEM TOO RICH BANK 1 —, Diagnostic Trouble Code (DTC) Detecting Criteria.>

CAUTION:

After repair or replacement of faulty parts, conduct Clear Memory Mode <Ref. to EN(H4DOTC)-44, OPERATION, Clear Memory Mode.> and Inspection Mode <Ref. to EN(H4DOTC)-36, OPERATION, Inspection Mode.>.

WIRING DIAGRAM:

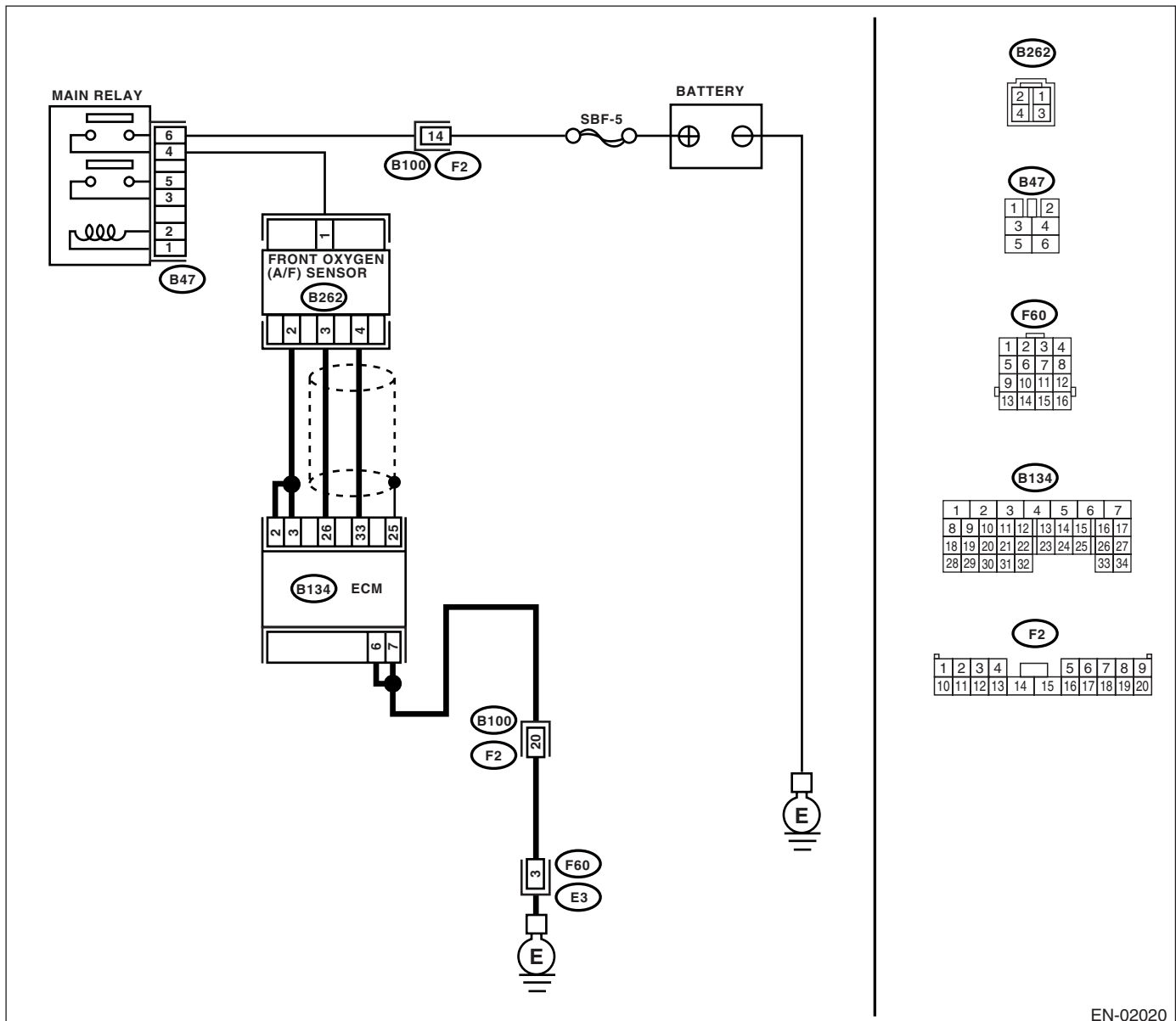

EN-02020

DIAGNOSTIC PROCEDURE WITH DIAGNOSTIC TROUBLE CODE (DTC)

ENGINE (DIAGNOSTICS)

Step	Check	Yes	No	
1	CHECK ANY OTHER DTC ON DISPLAY.	Is any other DTC displayed?	Inspect the relevant DTC using "List of Diagnostic Trouble Code (DTC)". <Ref. to EN(H4DOTC)-68, List of Diagnostic Trouble Code (DTC).>	Go to step 2.
2	CHECK FRONT (A/F) OXYGEN SENSOR DATA. 1) Start engine. 2) While observing the Subaru Select Monitor or OBD-II general scan tool screen, warm-up the engine until coolant temperature is above 75°C (167°F). If the engine is already warmed-up, operate at idle speed for at least 1 minute. 3) Read data of front oxygen (A/F) sensor signal using Subaru Select Monitor or OBD-II general scan tool. NOTE: • Subaru Select Monitor For detailed operation procedure, refer to the "READ CURRENT DATA FOR ENGINE". <Ref. to EN(H4DOTC)-29, Subaru Select Monitor.> • OBD-II general scan tool For detailed operation procedures, refer to the OBD-II General Scan Tool Instruction Manual.	Is the measured value within 0.86 — 1.15 at idle?	Go to step 3.	Go to step 4.
3	CHECK REAR OXYGEN SENSOR SIGNAL. 1) Race engine at speeds from idling to 5,000 rpm for a total of 5 cycles. NOTE: To increase engine speed to 5,000 rpm, slowly depress accelerator pedal, taking approximately 5 seconds, and quickly release accelerator pedal to decrease engine speed. 2) Operate the LED operation mode for engine. NOTE: • Subaru Select Monitor For detailed operation procedure, refer to the "LED OPERATION MODE FOR ENGINE". <Ref. to EN(H4DOTC)-29, Subaru Select Monitor.>	Does the LED of {Rear O ₂ Rich Signal} blink?	Check front oxygen (A/F) sensor circuit.	Check rear oxygen sensor circuit. <Ref. to FU(H4DOTC)-39, Rear Oxygen Sensor.>
4	CHECK EXHAUST SYSTEM. Check exhaust system parts. NOTE: Check the following items. • Loose installation of portions • Damage (crack, hole etc.) of parts • Looseness of front oxygen (A/F) sensor • Looseness and ill fitting of parts between front oxygen (A/F) sensor and rear oxygen sensor	Is there a fault in exhaust system?	Repair or replace faulty parts.	Go to step 5.
5	CHECK AIR INTAKE SYSTEM.	Are there holes, loose bolts or disconnection of hose on air intake system?	Repair the air intake system.	Go to step 6.

DIAGNOSTIC PROCEDURE WITH DIAGNOSTIC TROUBLE CODE (DTC)

ENGINE (DIAGNOSTICS)

Step	Check	Yes	No
<p>6 CHECK FUEL PRESSURE.</p> <p>Warning:</p> <ul style="list-style-type: none"> • Place “NO FIRE” signs near the working area. • Be careful not to spill fuel on the floor. <ol style="list-style-type: none"> 1) Release the fuel pressure. <ol style="list-style-type: none"> (1) Disconnect the connector from fuel pump relay. (2) Start the engine and run it until it stalls. (3) After the engine stalls, crank it for 5 more seconds. (4) Turn the ignition switch to OFF. 2) Connect the connector to fuel pump relay. 3) Disconnect the fuel delivery hose from fuel filter, and connect fuel pressure gauge. 4) Install the fuel filler cap. 5) Start the engine and idle while gear position is neutral. 6) Measure the fuel pressure while disconnecting pressure regulator vacuum hose from intake manifold. <p>Warning: Before removing the fuel pressure gauge, release fuel pressure.</p> <p>NOTE: If the fuel pressure does not increase, squeeze fuel return hose 2 to 3 times, then measure fuel pressure again.</p>	<p>Is the measured value 284 — 314 kPa (2.9 — 3.2 kg/cm², 41 — 46 psi)?</p>	<p>Go to step 7.</p>	<p>Repair the following items.</p> <p>Fuel pressure too high:</p> <ul style="list-style-type: none"> • Clogged fuel return line or bent hose <p>Fuel pressure too low:</p> <ul style="list-style-type: none"> • Improper fuel pump discharge • Clogged fuel supply line
<p>7 CHECK FUEL PRESSURE.</p> <p>After connecting the pressure regulator vacuum hose, measure fuel pressure.</p> <p>Warning: Before removing the fuel pressure gauge, release fuel pressure.</p> <p>NOTE:</p> <ul style="list-style-type: none"> • If the fuel pressure does not increase, squeeze fuel return hose 2 to 3 times, then measure fuel pressure again. • If out of specification as measured at this step, check or replace the pressure regulator and pressure regulator vacuum hose. 	<p>Is the measured value 206 — 235 kPa (2.1 — 2.4 kg/cm², 30 — 34 psi)?</p>	<p>Go to step 8.</p>	<p>Repair the following items.</p> <p>Fuel pressure too high:</p> <ul style="list-style-type: none"> • Faulty pressure regulator • Clogged fuel return line or bent hose <p>Fuel pressure too low:</p> <ul style="list-style-type: none"> • Faulty pressure regulator • Improper fuel pump discharge • Clogged fuel supply line
<p>8 CHECK ENGINE COOLANT TEMPERATURE SENSOR.</p> <ol style="list-style-type: none"> 1) Start the engine and warm-up completely. 2) Read the data of engine coolant temperature sensor signal using Subaru Select Monitor or OBD-II general scan tool. <p>NOTE:</p> <ul style="list-style-type: none"> • Subaru Select Monitor <p>For detailed operation procedure, refer to the “READ CURRENT DATA FOR ENGINE”. <Ref. to EN(H4DOTC)-29, Subaru Select Monitor.></p> <ul style="list-style-type: none"> • OBD-II general scan tool <p>For detailed operation procedures, refer to the OBD-II General Scan Tool Instruction Manual.</p>	<p>Is the temperature more than 60°C (140°F)?</p>	<p>Go to step 9.</p>	<p>Replace the engine coolant temperature sensor. <Ref. to FU(H4DOTC)-26, Engine Coolant Temperature Sensor.></p>

DIAGNOSTIC PROCEDURE WITH DIAGNOSTIC TROUBLE CODE (DTC)

ENGINE (DIAGNOSTICS)

Step	Check	Yes	No
<p>9 CHECK MASS AIR FLOW AND INTAKE AIR TEMPERATURE.</p> <p>1) Start the engine and warm-up engine until coolant temperature is greater than 60°C (140°F).</p> <p>2) Place the shift lever in neutral position.</p> <p>3) Turn the A/C switch to OFF.</p> <p>4) Turn all accessory switches to OFF.</p> <p>5) Read the data of mass air flow and intake air temperature sensor signal using Subaru Select Monitor or OBD-II general scan tool.</p> <p>NOTE:</p> <ul style="list-style-type: none"> • Subaru Select Monitor <p>For detailed operation procedure, refer to the "READ CURRENT DATA FOR ENGINE". <Ref. to EN(H4DOTC)-29, Subaru Select Monitor.></p> <ul style="list-style-type: none"> • OBD-II general scan tool <p>For detailed operation procedure, refer to the OBD-II General Scan Tool Instruction Manual.</p>	<p>Is the measured value within the followings? Ignition ON: 73.3 — 106.6 kPa (550 — 800 mmHg, 21.65 — 31.50 inHg) Idling: 24.0 — 41.3 kPa (180 — 310 mmHg, 7.09 — 12.20 inHg)</p>	<p>Go to step 10.</p>	<p>Replace the mass air flow and intake air temperature sensor. <Ref. to FU(H4DOTC)-30, Mass Air Flow and Intake Air Temperature Sensor.></p>
<p>10 CHECK MASS AIR FLOW AND INTAKE AIR TEMPERATURE SENSOR.</p> <p>1) Start the engine and warm-up engine until coolant temperature is greater than 60°C (140°F).</p> <p>2) Place the shift lever in neutral position.</p> <p>3) Turn the A/C switch to OFF.</p> <p>4) Turn all accessory switches to OFF.</p> <p>5) Open the front hood.</p> <p>6) Measure the ambient temperature.</p> <p>7) Read the data of mass air flow and intake air temperature sensor signal using Subaru Select Monitor or OBD-II general scan tool.</p> <p>NOTE:</p> <ul style="list-style-type: none"> • Subaru Select Monitor <p>For detailed operation procedure, refer to the "READ CURRENT DATA FOR ENGINE". <Ref. to EN(H4DOTC)-29, Subaru Select Monitor.></p> <ul style="list-style-type: none"> • OBD-II general scan tool <p>For detailed operation procedure, refer to the OBD-II General Scan Tool Instruction Manual.</p>	<p>Subtract ambient temperature from intake air temperature. Is the obtained value -10 — 50°C (14 — 122°F)?</p>	<p>Go to step 11.</p>	<p>Check the mass air flow and intake air temperature sensor. <Ref. to FU(H4DOTC)-30, Mass Air Flow and Intake Air Temperature Sensor.></p>
<p>11 CHECK HARNESS BETWEEN ECM AND FRONT OXYGEN (A/F) SENSOR CONNECTOR.</p> <p>1) Turn the ignition switch to OFF.</p> <p>2) Disconnect the connectors from ECM and front oxygen (A/F) sensor connector.</p> <p>3) Measure the resistance of harness between ECM and front oxygen (A/F) sensor connector.</p> <p>Connector & terminal (B134) No. 26 — Chassis ground: (B134) No. 33 — Chassis ground:</p>	<p>Is the resistance more than 1 MΩ?</p>	<p>Go to step 12.</p>	<p>Repair ground short circuit in harness between ECM and front oxygen (A/F) sensor connector.</p>

DIAGNOSTIC PROCEDURE WITH DIAGNOSTIC TROUBLE CODE (DTC)

ENGINE (DIAGNOSTICS)

Step	Check	Yes	No
<p>12 CHECK HARNESS BETWEEN ECM AND FRONT OXYGEN (A/F) SENSOR CONNECTOR.</p> <p>1) Turn the ignition switch to OFF. 2) Disconnect the connectors from front oxygen (A/F) sensor. 3) Measure the voltage of harness between ECM connector and chassis ground.</p> <p>Connector & terminal (B134) No. 26 (+) — Chassis ground (-): (B134) No. 33 (+) — Chassis ground (-):</p>	<p>Is the voltage more than 8 V?</p>	<p>Go to step 13.</p>	<p>Repair battery short circuit in harness between ECM and front oxygen (A/F) sensor connector.</p>
<p>13 CHECK HARNESS BETWEEN ECM AND FRONT OXYGEN (A/F) SENSOR CONNECTOR.</p> <p>1) Turn the ignition switch to OFF. 2) Disconnect the connectors from ECM and front oxygen (A/F) sensor connector. 3) Measure the resistance of harness between ECM and front oxygen (A/F) sensor connector.</p> <p>Connector & terminal (B134) No. 26 — (B262) No. 3: (B134) No. 33 — (B262) No. 4:</p>	<p>Is the resistance less than 1 Ω?</p>	<p>Replace the front oxygen (A/F) sensor. <Ref. to FU(H4DOTC)-37, Front Oxygen (A/F) Sensor.></p>	<p>Repair open circuit in harness between ECM and front oxygen (A/F) sensor connector.</p>

DIAGNOSTIC PROCEDURE WITH DIAGNOSTIC TROUBLE CODE (DTC)

ENGINE (DIAGNOSTICS)

DQ:DTC P2101 — THROTTLE ACTUATOR CONTROL MOTOR CIRCUIT RANGE/ PERFORMANCE —

DTC DETECTING CONDITION:

- Immediately at fault recognition
- GENERAL DESCRIPTION <Ref. to GD(H4DOTC)-187, DTC P0638 — THROTTLE ACTUATOR CONTROL RANGE/PERFORMANCE (BANK 1) —, Diagnostic Trouble Code (DTC) Detecting Criteria.> <Ref. to GD(H4DOTC)-225, DTC P1160 — RETURN SPRING FAILURE —, Diagnostic Trouble Code (DTC) Detecting Criteria.> <Ref. to GD(H4DOTC)-260, DTC P2101 — THROTTLE ACTUATOR CONTROL MOTOR CIRCUIT RANGE/PERFORMANCE —, Diagnostic Trouble Code (DTC) Detecting Criteria.>

TROUBLE SYMPTOM:

- Erroneous idling
- Poor driving performance
- Engine stalls.

CAUTION:

After repair or replacement of faulty parts, conduct Clear Memory Mode <Ref. to EN(H4DOTC)-44, OPERATION, Clear Memory Mode.> and Inspection Mode <Ref. to EN(H4DOTC)-36, OPERATION, Inspection Mode.>.

DIAGNOSTIC PROCEDURE WITH DIAGNOSTIC TROUBLE CODE (DTC) ENGINE (DIAGNOSTICS)

WIRING DIAGRAM:

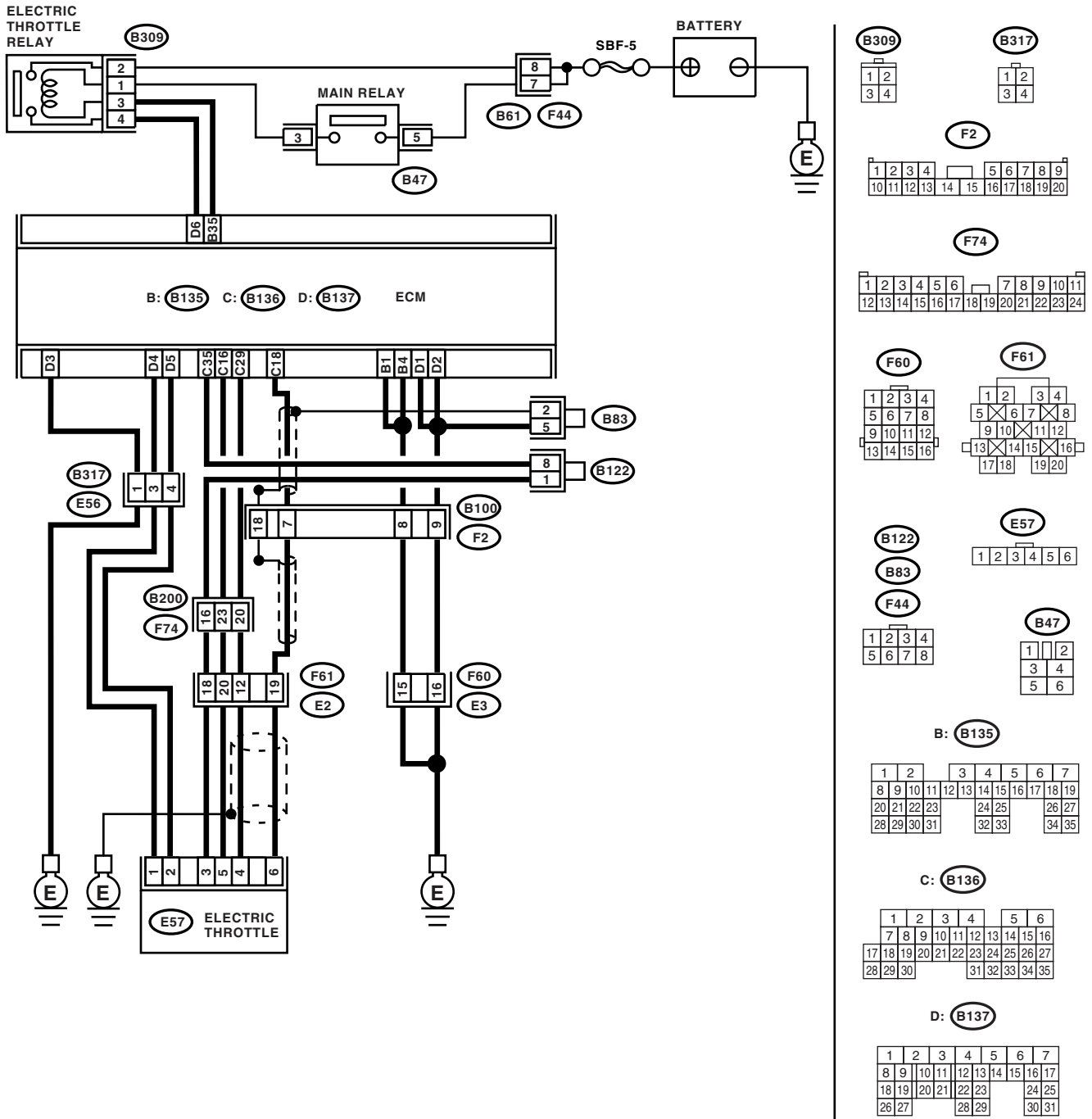

EN-02025

DIAGNOSTIC PROCEDURE WITH DIAGNOSTIC TROUBLE CODE (DTC)

ENGINE (DIAGNOSTICS)

Step	Check	Yes	No
1 CHECK ELECTRIC THROTTLE RELAY. 1) Turn the ignition switch to OFF. 2) Remove the electric throttle relay. 3) Connect the battery to electric throttle relay terminal No. 1 and No. 3. 4) Measure the resistance between electric throttle relay terminals. Terminals No. 2 — No. 4:	Is the resistance less than 1 Ω ?	Go to step 2.	Replace the electric throttle relay.
2 CHECK POWER SUPPLY TO ELECTRIC THROTTLE RELAY. Measure the voltage between electric throttle relay connector and engine ground. Connector & terminal (B309) No. 1 (+) — Engine ground (-): (B309) No. 2 (+) — Engine ground (-):	Is the voltage more than 5 V?	Go to step 3.	Repair the open power supply circuit or ground short.
3 CHECK HARNESS BETWEEN ECM AND ELECTRIC THROTTLE. 1) Disconnect the connector from ECM. 2) Turn the ignition switch to ON. 3) Measure the voltage between electric throttle relay connector and engine ground. Connector & terminal (B309) No. 3 (+) — Engine ground (-):	Is the voltage less than 5 V?	Go to step 4.	Repair short of the power supply circuit between ECM and electric throttle.
4 CHECK HARNESS BETWEEN ECM AND ELECTRIC THROTTLE. 1) Turn the ignition switch to OFF. 2) Measure the resistance between electric throttle relay connector and chassis ground. Connector & terminal (B309) No. 3 — Engine ground: (B309) No. 4 — Engine ground:	Is the resistance more than 1 M Ω ?	Go to step 5.	Repair the ground short of harness between ECM and electric throttle relay.
5 CHECK HARNESS BETWEEN ECM AND ELECTRIC THROTTLE RELAY. 1) Turn the ignition switch to OFF. 2) Measure the resistance between electric throttle connector and electric throttle relay connector. Connector & terminal (B135) No. 35 — (B309) No. 3: (B137) No. 6 — (B309) No. 4:	Is the resistance less than 1 Ω ?	Go to step 6.	Repair the open circuit of harness between ECM and electric throttle relay.
6 CHECK OUTPUT VOLTAGE OF SENSOR. 1) Connect all the connectors. 2) Turn the ignition switch to ON. 3) Measure the voltage between ECM connector terminals. Connector & terminal (B136) No. 18 (+) — (B136) No. 35 (-): 4) Shake the ECM harness and connector, engine harness connectors (B136, F61), electric throttle connector harness while monitoring value of voltage meter.	Is the voltage more than 0.4 V?	Go to step 7.	Go to step 9.

DIAGNOSTIC PROCEDURE WITH DIAGNOSTIC TROUBLE CODE (DTC)

ENGINE (DIAGNOSTICS)

Step	Check	Yes	No
<p>7 CHECK OUTPUT VOLTAGE OF SENSOR. 1) Connect all the connectors. 2) Turn the ignition switch to ON. 3) Measure the voltage between ECM connector terminals. <i>Connector & terminal</i> <i>(B136) No. 29 (+) — (B136) No. 35 (-):</i> 4) Shake the ECM harness and connector, engine harness connectors, electric throttle connector harness while monitoring value of voltage meter.</p>	Is the voltage more than 0.8 V?	Go to step 8.	Go to step 9.
<p>8 CHECK POOR CONTACT. Check poor contact between ECM connector and electric throttle connector.</p>	Is there poor contact between ECM connector and electric throttle connector?	Repair the poor contact.	Go to step 13.
<p>9 CHECK HARNESS BETWEEN ECM AND ELECTRIC THROTTLE. 1) Turn the ignition switch to OFF. 2) Disconnect the connector from ECM. 3) Disconnect the connector from electric throttle. 4) Measure the resistance between ECM connector and electric throttle connector. <i>Connector & terminal</i> <i>(B136) No. 16 — (E57) No. 5:</i></p>	Is the resistance less than 1 Ω ?	Go to step 10.	Repair the open harness connector.
<p>10 CHECK THE HARNESS BETWEEN ECM AND ELECTRIC THROTTLE. Measure the resistance between ECM connector and chassis ground. <i>Connector & terminal</i> <i>(B136) No. 16 — Chassis ground:</i> <i>(B136) No. 18 — Chassis ground:</i> <i>(B136) No. 29 — Chassis ground:</i></p>	Is the resistance more than 1 M Ω ?	Go to step 11.	Repair the ground short of harness.
<p>11 CHECK POWER SUPPLY TO SENSOR. 1) Connect the ECM connector. 2) Turn the ignition switch to ON. 3) Measure the resistance between electric throttle connector and engine ground. <i>Connector & terminal</i> <i>(E57) No.5 (+) — Engine ground (-):</i> 4) Shake the ECM harness and connector, engine harness connectors, while monitoring value of voltage meter.</p>	Is the voltage 4.5 — 5.5 V?	Go to step 12.	Repair the poor contact in ECM connector. If problem persists, replace the ECM. <Ref. to FU(H4DOTC)-42, Engine Control Module (ECM).>
<p>12 CHECK SHORT OF ECM. 1) Turn the ignition switch to OFF. 2) Measure the resistance between electric throttle connector and engine ground. <i>Connector & terminal</i> <i>(E57) No. 6 — Engine ground:</i> <i>(E57) No. 4 — Engine ground:</i></p>	Is the resistance more than 10 Ω ?	Go to step 13.	Repair the poor contact in ECM connector. If problem persists, replace the ECM.
<p>13 CHECK OUTPUT VOLTAGE OF SENSOR. 1) Connect all the connectors. 2) Turn the ignition switch to ON. 3) Read the data of main throttle sensor signal, using the Subaru Select Monitor. 4) Shake the ECM harness and connector, engine harness connectors, electric throttle connector harness while monitoring value of voltage meter.</p>	Is the voltage 4.63 V?	Go to step 14.	Go to step 16.

DIAGNOSTIC PROCEDURE WITH DIAGNOSTIC TROUBLE CODE (DTC)

ENGINE (DIAGNOSTICS)

Step	Check	Yes	No
14 CHECK OUTPUT VOLTAGE OF SENSOR. 1) Read the data of sub throttle sensor signal, using the Subaru Select Monitor. 2) Shake the ECM harness and connector, engine harness connectors, electric throttle connector harness while monitoring value of voltage meter.	Is the voltage 4.73 V?	Go to step 15.	Go to step 16.
15 CHECK POOR CONTACT IN CONNECTORS. Check poor contact in connectors between ECM and electric throttle?	Is there poor contact in connectors between ECM and electric throttle?	Repair the poor contact in connectors.	Go to step 21.
16 CHECK HARNESS BETWEEN ECM AND ELECTRIC THROTTLE. 1) Turn the ignition switch to OFF. 2) Disconnect the connector from ECM. 3) Disconnect the connector from electric throttle. 4) Measure the resistance between ECM connector and electric throttle connector. Connector & terminal (B136) No. 35 — (E57) No. 3: (B136) No. 18 — (E57) No. 6: (B136) No. 29 — (E57) No. 4:	Is the resistance less than 1 Ω ?	Go to step 17.	Repair the open harness connector.
17 CHECK HARNESS BETWEEN ECM AND ELECTRIC THROTTLE. 1) Connect the ECM connector. 2) Measure the resistance between electric throttle connector and engine ground. Connector & terminal (E57) No. 3 — Engine ground:	Is the resistance less than 5 Ω ?	Go to step 18.	Repair the poor contact in ECM connector. If problem persists, replace the ECM.
18 CHECK HARNESS BETWEEN ECM AND ELECTRIC THROTTLE. 1) Turn the ignition switch to ON. 2) Measure the voltage between electric throttle connector and engine ground. Connector & terminal (E57) No. 5 (+) — Engine ground (-): 3) Shake the ECM harness and connector, engine harness connectors, while monitoring value of voltage meter.	Is the voltage more than 10 V?	Go to step 19.	Repair the battery short of harness between ECM connector and electric throttle connector.
19 CHECK HARNESS BETWEEN ECM AND ELECTRIC THROTTLE. 1) Measure the voltage between electric throttle connector and engine ground. Connector & terminal (E57) No. 6 (+) — Engine ground (-): (E57) No. 4 (+) — Engine ground (-): 2) Shake the ECM harness and connector, engine harness connectors, while monitoring value of voltage meter.	Is the voltage less than 10 V?	Go to step 20.	Repair the short of harness between ECM connector and electric throttle connector.
20 CHECK HARNESS BETWEEN ECM AND ELECTRIC THROTTLE. 1) Turn the ignition switch to OFF. 2) Remove the ECM. 3) Measure the voltage between ECM connectors. Connector & terminal (B136) No. 18 — (B136) No. 35: (B136) No. 29 — (B136) No. 35:	Is the resistance more than 1 M Ω ?	Go to step 21.	Repair the short of sensor power supply.

DIAGNOSTIC PROCEDURE WITH DIAGNOSTIC TROUBLE CODE (DTC)

ENGINE (DIAGNOSTICS)

Step	Check	Yes	No
21 CHECK OUTPUT VOLTAGE OF SENSOR. 1) Turn the ignition switch to OFF. 2) Connect all the connectors except electric throttle replay. 3) Turn the ignition switch to ON. 4) Read the data of main throttle sensor signals, using Subaru Select Monitor.	Is the voltage 0.81 — 0.87 V?	Go to step 22 .	Repair the poor contact in electric throttle connector. If problem persists, replace the electric throttle.
22 CHECK OUTPUT VOLTAGE OF SENSOR. Read the data of sub throttle sensor signals, using Subaru Select Monitor.	Is the voltage 1.64 — 1.70 V?	Go to step 23 .	Repair the poor contact in electric throttle connector. If problem persists, replace the electric throttle.
23 CHECK HARNESS BETWEEN ECM AND ELECTRIC THROTTLE MOTOR. 1) Turn the ignition switch to OFF. 2) Disconnect the connector from ECM. 3) Disconnect the connectors from electric throttle. 4) Measure the resistance between ECM connector and electric throttle connector. <i>Connector & terminal</i> <i>(B137) No. 5 — (E57) No. 2:</i> <i>(B137) No. 4 — (E57) No. 1:</i>	Is the resistance less than 1 Ω ?	Go to step 24 .	Repair the open harness connector.
24 CHECK HARNESS BETWEEN ECM AND ELECTRIC THROTTLE MOTOR. 1) Connect the connectors to ECM. 2) Turn the ignition switch to ON. 3) Measure the voltage between electric throttle connector and engine ground. <i>Connector & terminal</i> <i>(E57) No. 2 (+) — Engine ground (-):</i> <i>(E57) No. 1 (+) — Engine ground (-):</i>	Is the voltage less than 5 V?	Go to step 25 .	Repair the short of harness to power supply circuit between ECM and electric throttle.
25 CHECK HARNESS BETWEEN ECM AND ELECTRIC THROTTLE MOTOR. 1) Turn the ignition switch to OFF. 2) Disconnect the connector from ECM. 3) Measure the resistance between electric throttle connector and engine ground. <i>Connector & terminal</i> <i>(E57) No. 2 — Engine ground:</i> <i>(E57) No. 1 — Engine ground:</i>	Is the resistance more than 1 $M\Omega$?	Go to step 26 .	Repair the short of harness.
26 CHECK ELECTRIC THROTTLE MOTOR HARNESS. Measure the resistance between electric throttle connector terminals. <i>Connector & terminal</i> <i>(E57) No. 2 — (E57) No. 1:</i>	Is the resistance more than 1 $M\Omega$?	Go to step 27 .	Repair the short of harness.
27 CHECK ELECTRIC THROTTLE GROUND CIRCUIT. Measure the resistance between ECM connector and engine ground. <i>Connector & terminal</i> <i>(B137) No. 3 — Engine ground:</i>	Is the resistance less than 10 Ω ?	Go to step 28 .	Repair the open circuit harness.
28 CHECK ELECTRIC THROTTLE. Measure the resistance between electric throttle terminals. <i>Terminals</i> <i>No. 1 — No. 2:</i>	Is the resistance less than 5 Ω ?	Go to step 29 .	Replace the electric throttle.

DIAGNOSTIC PROCEDURE WITH DIAGNOSTIC TROUBLE CODE (DTC)

ENGINE (DIAGNOSTICS)

Step	Check	Yes	No
29 CHECK ELECTRIC THROTTLE. Open and close the throttle valve to its full width with finger.	Does it return to specified position (3 mm (0.12 in) open from fully closed position.) when finger is released?	Repair the poor contact in ECM connector. If problem persists, replace the ECM. <Ref. to FU(H4DOTC)-42, Engine Control Module (ECM).>	Replace the electric throttle.

DR:DTC P2102 — THROTTLE ACTUATOR CONTROL MOTOR CIRCUIT LOW —

DTC DETECTING CONDITION:

- Immediately at fault recognition
- GENERAL DESCRIPTION <Ref. to GD(H4DOTC)-262, DTC P2102 — THROTTLE ACTUATOR CONTROL MOTOR CIRCUIT LOW —, Diagnostic Trouble Code (DTC) Detecting Criteria.>

TROUBLE SYMPTOM:

- Erroneous idling
- Poor driving performance
- Engine stalls.

CAUTION:

After repair or replacement of faulty parts, conduct Clear Memory Mode <Ref. to EN(H4DOTC)-44, OPERATION, Clear Memory Mode.> and Inspection Mode <Ref. to EN(H4DOTC)-36, OPERATION, Inspection Mode.>.

DIAGNOSTIC PROCEDURE WITH DIAGNOSTIC TROUBLE CODE (DTC)

ENGINE (DIAGNOSTICS)

WIRING DIAGRAM:

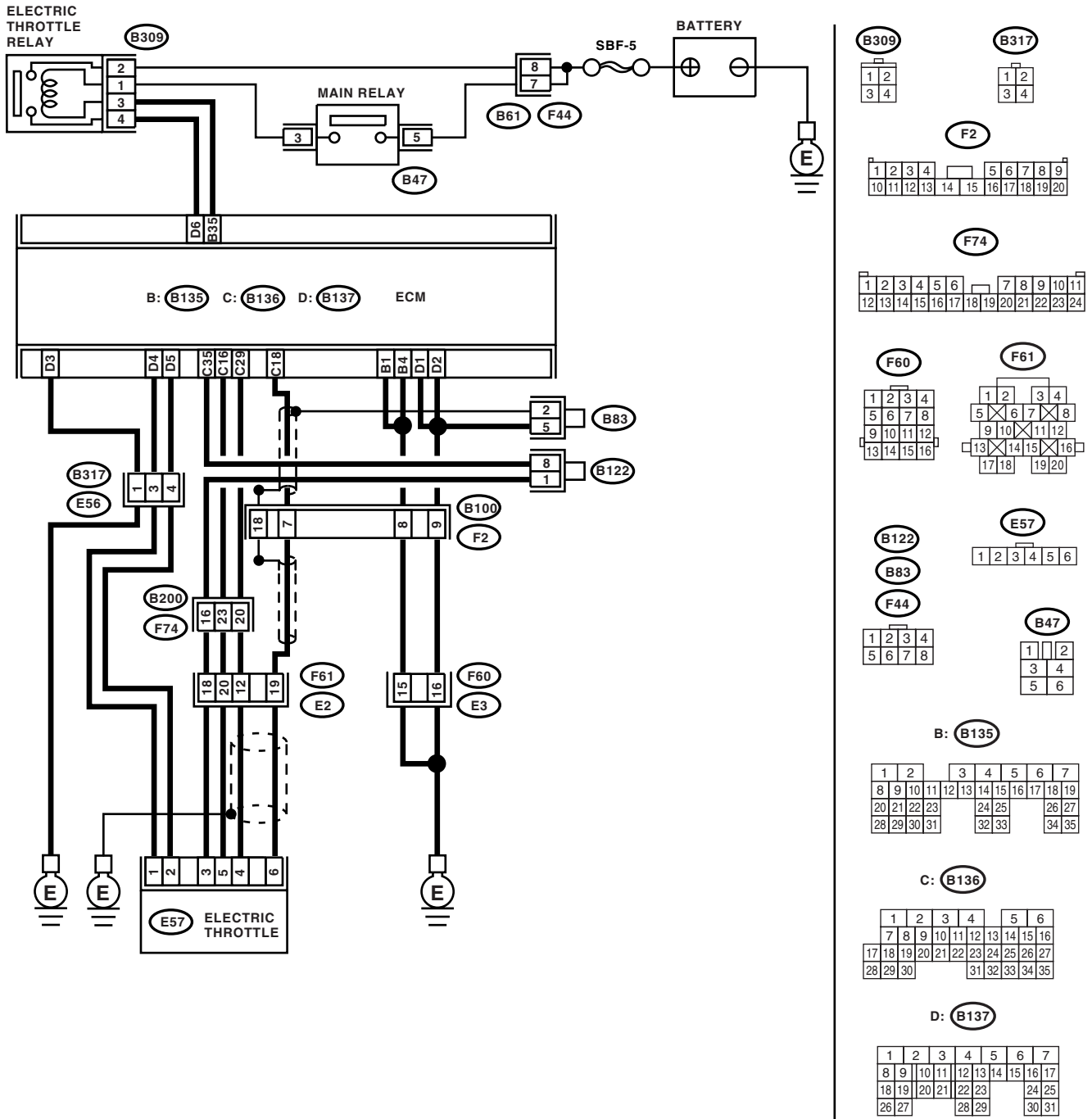

EN-02025

DIAGNOSTIC PROCEDURE WITH DIAGNOSTIC TROUBLE CODE (DTC)

ENGINE (DIAGNOSTICS)

Step	Check	Yes	No
1 CHECK ELECTRIC THROTTLE RELAY. 1) Turn the ignition switch to OFF. 2) Remove the electric throttle relay. 3) Connect the battery to electric throttle relay terminal No. 1 and No. 3. 4) Measure the resistance between electric throttle terminals. <i>Connector & terminal</i> <i>(B309) No. 2 — (B309) No. 4:</i>	Is the resistance less than 1 Ω ?	Go to step 2.	Replace the electric throttle relay.
2 CHECK POWER TO ELECTRIC THROTTLE RELAY Measure the voltage between electric throttle relay connector and engine ground. <i>Connector & terminal</i> <i>(B309) No. 1 (+) — Engine ground (-):</i> <i>(B309) No. 2 (+) — Engine ground (-):</i>	Is the voltage more than 5 V?	Go to step 3.	Repair the open power supply circuit or ground short.
3 CHECK HARNESS BETWEEN ECM AND ELECTRIC THROTTLE. 1) Disconnect the connector from ECM. 2) Turn the ignition switch to ON. 3) Measure the voltage between electric throttle relay connector and engine ground. <i>Connector & terminal</i> <i>(B309) No. 3 (+) — Engine ground (-):</i>	Is the voltage less than 5 V?	Go to step 4.	Repair the short of power supply circuit between ECM and electric throttle.
4 CHECK HARNESS BETWEEN ECM AND ELECTRIC THROTTLE RELAY. 1) Turn the ignition switch to OFF. 2) Measure the resistance between electric throttle relay connector and chassis ground. <i>Connector & terminal</i> <i>(B309) No. 3 — Engine ground:</i> <i>(B309) No. 4 — Engine ground:</i>	Is the resistance more than 1 M Ω ?	Go to step 5.	Repair the ground short of harness between ECM and electric throttle relay.
5 CHECK HARNESS BETWEEN ECM AND ELECTRIC THROTTLE RELAY. Measure the resistance between ECM connector and electric throttle relay connector. <i>Connector & terminal</i> <i>(B135) No. 35 — (B309) No. 3:</i> <i>(B137) No. 6 — (B309) No. 4:</i>	Is the resistance less than 1 Ω ?	Repair the poor contact in ECM connector. If problem persists, replace the ECM.	Repair the open harness between ECM and electric throttle relay.

DIAGNOSTIC PROCEDURE WITH DIAGNOSTIC TROUBLE CODE (DTC)

ENGINE (DIAGNOSTICS)

DS:DTC P2103 — THROTTLE ACTUATOR CONTROL MOTOR CIRCUIT HIGH — DTC DETECTING CONDITION:

- Immediately at fault recognition
- GENERAL DESCRIPTION <Ref. to GD(H4DOTC)-264, DTC P2103 — THROTTLE ACTUATOR CONTROL MOTOR CIRCUIT HIGH —, Diagnostic Trouble Code (DTC) Detecting Criteria.>

CAUTION:

After repair or replacement of faulty parts, conduct Clear Memory Mode <Ref. to EN(H4DOTC)-44, OPERATION, Clear Memory Mode.> and Inspection Mode <Ref. to EN(H4DOTC)-36, OPERATION, Inspection Mode.>.

DIAGNOSTIC PROCEDURE WITH DIAGNOSTIC TROUBLE CODE (DTC)

ENGINE (DIAGNOSTICS)

WIRING DIAGRAM:

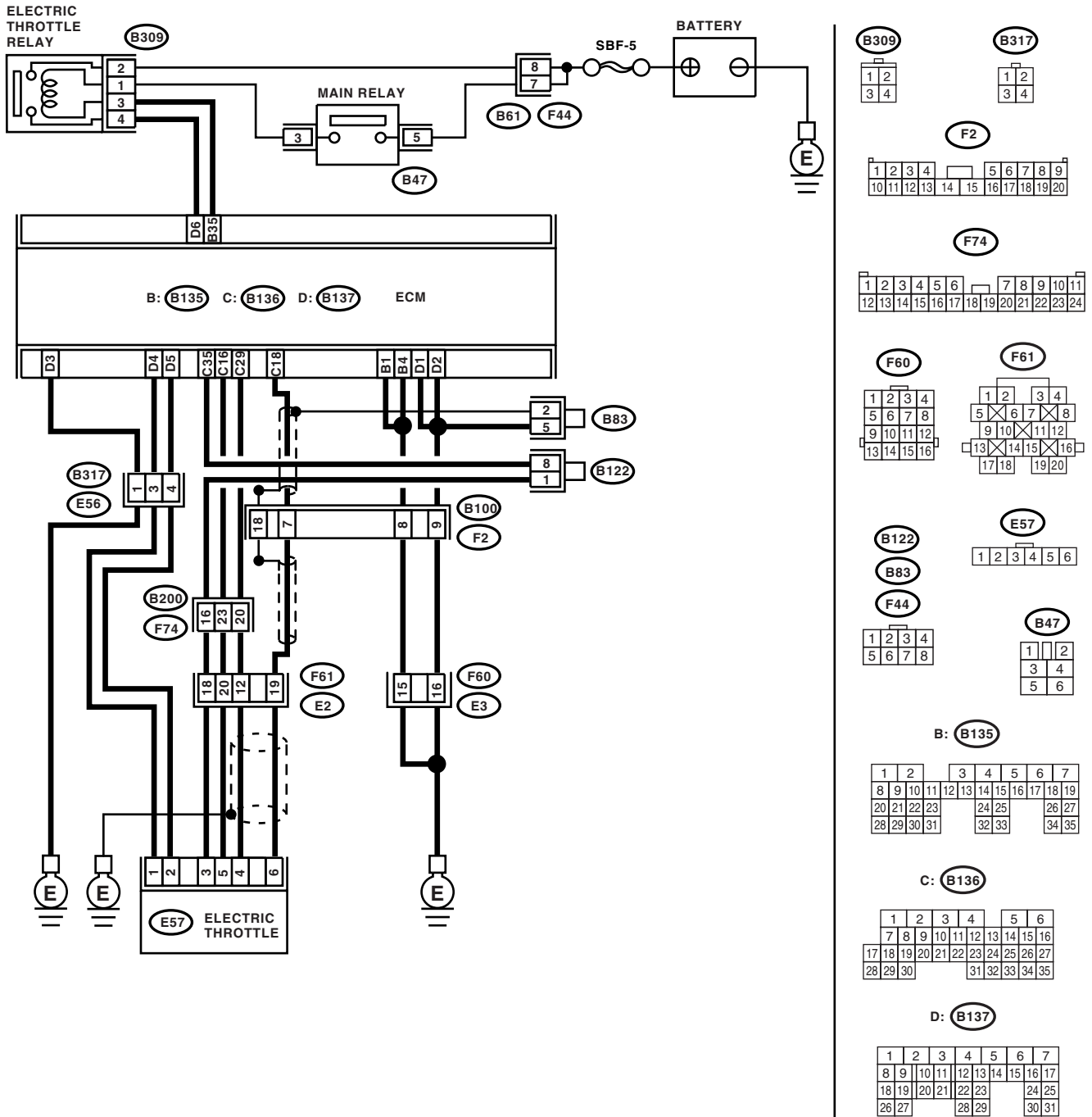

EN-02025

DIAGNOSTIC PROCEDURE WITH DIAGNOSTIC TROUBLE CODE (DTC)

ENGINE (DIAGNOSTICS)

Step	Check	Yes	No
1 CHECK ELECTRIC THROTTLE RELAY. 1) Turn the ignition switch to OFF. 2) Remove the electric throttle relay. 3) Measure the resistance between electric throttle relay terminals. Terminals No. 2 — No. 4:	Is the resistance more than 1 M Ω ?	Go to step 2.	Replace the electric throttle relay.
2 CHECK SHORT OF ELECTRIC THROTTLE RELAY POWER SUPPLY CIRCUIT. 1) Turn the ignition switch to ON. 2) Measure the voltage between electric throttle relay connector and engine ground. Connector & terminal (B309) No. 4 (+) — Engine ground (-):	Is the voltage more than 5 V?	Go to step 3.	Repair the short of power supply to harness between ECM and electric throttle relay.
3 CHECK HARNESS BETWEEN ECM AND ELECTRIC THROTTLE RELAY. 1) Turn the ignition switch to OFF. 2) Disconnect the connectors from ECM. 3) Measure the resistance between ECM connector and engine ground. Connector & terminal (B135) No. 35 — Engine ground:	Is the resistance more than 1 M Ω ?	Repair the poor contact in ECM connector. If problem persists, replace the ECM.	Repair the ground short of harness between ECM and electric throttle relay.

**DT:DTC P2109 — THROTTLE/PEDAL POSITION SENSOR A MINIMUM STOP
PERFORMANCE —**

NOTE:

For the diagnostic procedure, refer to DTC P2101. <Ref. to EN(H4DOTC)-348, DTC P2101 — THROTTLE ACTUATOR CONTROL MOTOR CIRCUIT RANGE/PERFORMANCE —, Diagnostic Procedure with Diagnostic Trouble Code (DTC).>

DIAGNOSTIC PROCEDURE WITH DIAGNOSTIC TROUBLE CODE (DTC)

ENGINE (DIAGNOSTICS)

DU:DTC P2122 — THROTTLE/PEDAL POSITION SENSOR/SWITCH “D” CIRCUIT LOW INPUT —

DTC DETECTING CONDITION:

- Immediately at fault recognition
- GENERAL DESCRIPTION <Ref. to GD(H4DOTC)-268, DTC P2122 — THROTTLE/PEDAL POSITION SENSOR/SWITCH “D” CIRCUIT LOW INPUT —, Diagnostic Trouble Code (DTC) Detecting Criteria.>

TROUBLE SYMPTOM:

- Erroneous idling
- Poor driving performance

CAUTION:

After repair or replacement of faulty parts, conduct Clear Memory Mode <Ref. to EN(H4DOTC)-44, OPERATION, Clear Memory Mode.> and Inspection Mode <Ref. to EN(H4DOTC)-36, OPERATION, Inspection Mode.>.

WIRING DIAGRAM:

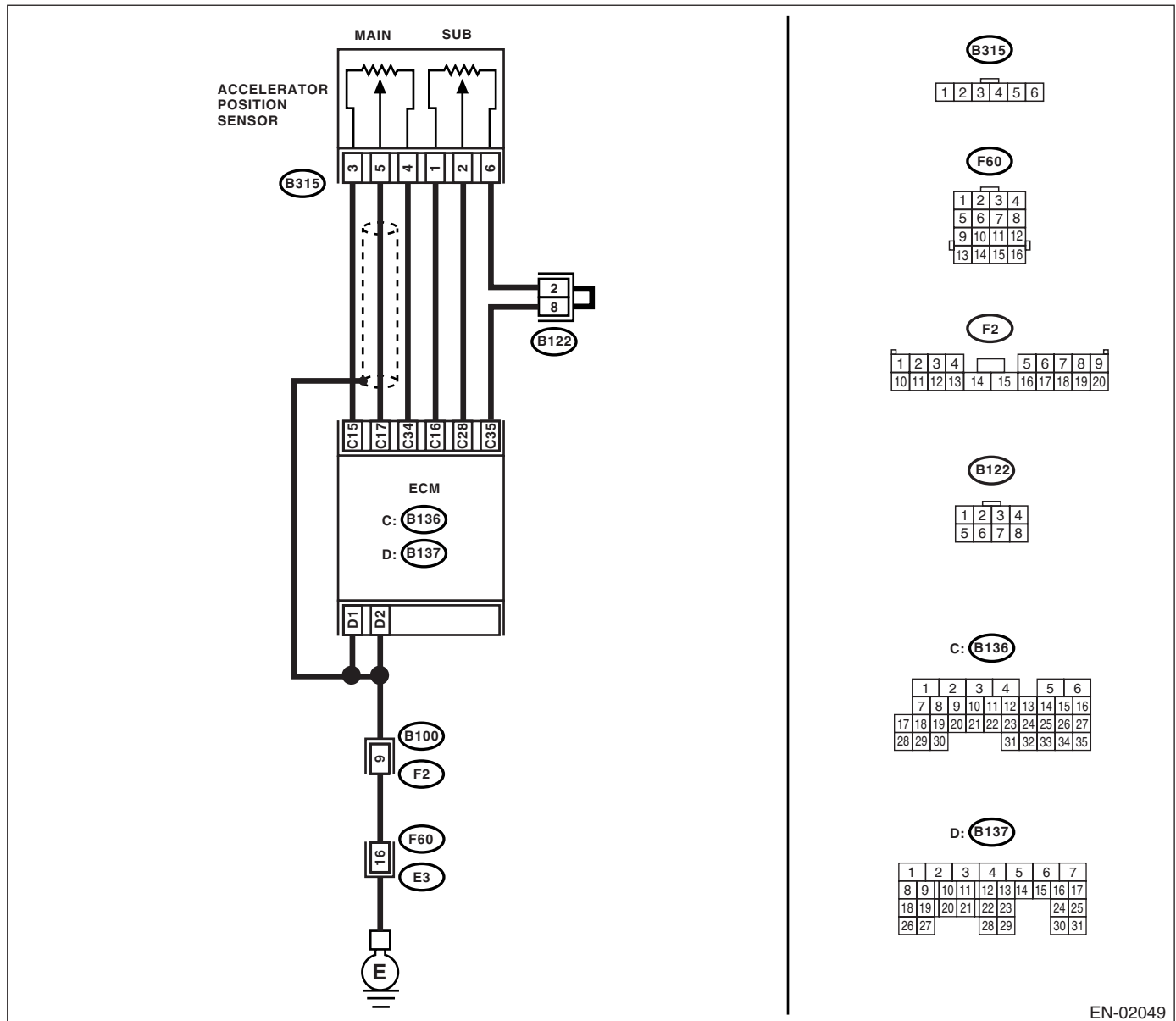

EN-02049

DIAGNOSTIC PROCEDURE WITH DIAGNOSTIC TROUBLE CODE (DTC)

ENGINE (DIAGNOSTICS)

Step	Check	Yes	No
<p>1</p> <p>CHECK OUTPUT VOLTAGE OF ACCELERATOR POSITION SENSOR. 1) Turn the ignition switch to ON. 2) Measure the voltage between ECM connector terminals. <i>Connector & terminal</i> (B136) No. 17 (+) — (B136) No. 34 (-): 3) Shake the ECM harness and connector, accelerator position sensor.</p>	Is the voltage more than 0.4 V?	Go to step 2.	Go to step 3.
<p>2</p> <p>CHECK POOR CONTACT IN CONNECTORS. Check poor contact in connectors between ECM and accelerator position sensor.</p>	Is there poor contact in connectors between ECM and accelerator position sensor?	Repair the poor contact in connectors.	Connector has returned to its normal condition at this time. A temporary poor contact of the connector may be the cause.
<p>3</p> <p>CHECK HARNESS BETWEEN ECM AND ACCELERATOR POSITION SENSOR. 1) Turn the ignition switch to OFF. 2) Disconnect the connector from ECM. 3) Disconnect the connector from accelerator position sensor. 4) Measure the resistance between ECM connector and accelerator position sensor. <i>Connector & terminal</i> (B136) No. 17 — (B315) No. 5: (B136) No. 15 — (B315) No. 3:</p>	Is the resistance less than 1 Ω ?	Go to step 4.	Repair the open harness connector.
<p>4</p> <p>CHECK HARNESS BETWEEN ECM AND ACCELERATOR POSITION SENSOR. Measure the resistance between ECM connector and chassis ground. <i>Connector & terminal</i> (B136) No. 17 — Chassis ground: (B136) No. 15 — Chassis ground:</p>	Is the resistance more than 1 M Ω ?	Go to step 5.	Repair the open harness connector.
<p>5</p> <p>CHECK ACCELERATOR POSITION SENSOR POWER SUPPLY 1) Connect the ECM connector. 2) Turn the ignition switch to ON. 3) Measure the voltage between accelerator position sensor connector and engine ground. <i>Connector & terminal</i> (B315) No. 3 (+) — Engine ground (-): 4) Shake the ECM harness and connector, while monitoring value of voltage meter.</p>	Is the voltage 4.5 — 5.5 V?	Go to step 6.	Repair the poor contact in ECM connector. If problem persists, replace the ECM. <Ref. to FU(H4DOTC)-42, Engine Control Module (ECM).>
<p>6</p> <p>CHECK ACCELERATOR POSITION SENSOR. Measure the resistance of accelerator position sensor. <i>Terminals</i> No. 3 — No. 4:</p>	Is the resistance 1.2 — 4.8 k Ω ?	Go to step 7.	Replace the accelerator position sensor.
<p>7</p> <p>CHECK ACCELERATOR POSITION SENSOR. Measure the resistance of accelerator position sensor when accelerator pedal is released. <i>Terminals</i> No. 5 — No. 4:</p>	Is the resistance 0.2 — 1.0 k Ω ?	Go to step 8.	Replace the accelerator position sensor.

DIAGNOSTIC PROCEDURE WITH DIAGNOSTIC TROUBLE CODE (DTC)

ENGINE (DIAGNOSTICS)

Step	Check	Yes	No
8 CHECK ACCELERATOR POSITION SENSOR. Measure the resistance of accelerator position sensor when acceleration pedal is being depressed. <i>Terminals</i> <i>No. 5 — No. 4:</i>	Is the resistance 0.5 — 2.5 k Ω ?	Repair the poor contact in ECM connector. If problem persists, replace the ECM.	Replace the accelerator position sensor.

DV:DTC P2123 — THROTTLE/PEDAL POSITION SENSOR/SWITCH “D” CIRCUIT HIGH INPUT —

DTC DETECTING CONDITION:

- Immediately at fault recognition
- GENERAL DESCRIPTION <Ref. to GD(H4DOTC)-270, DTC P2123 — THROTTLE/PEDAL POSITION SENSOR/SWITCH “D” CIRCUIT HIGH INPUT —, Diagnostic Trouble Code (DTC) Detecting Criteria.>

TROUBLE SYMPTOM:

- Erroneous idling
- Poor driving performance

CAUTION:

After repair or replacement of faulty parts, conduct Clear Memory Mode <Ref. to EN(H4DOTC)-44, OPERATION, Clear Memory Mode.> and Inspection Mode <Ref. to EN(H4DOTC)-36, OPERATION, Inspection Mode.>.

WIRING DIAGRAM:

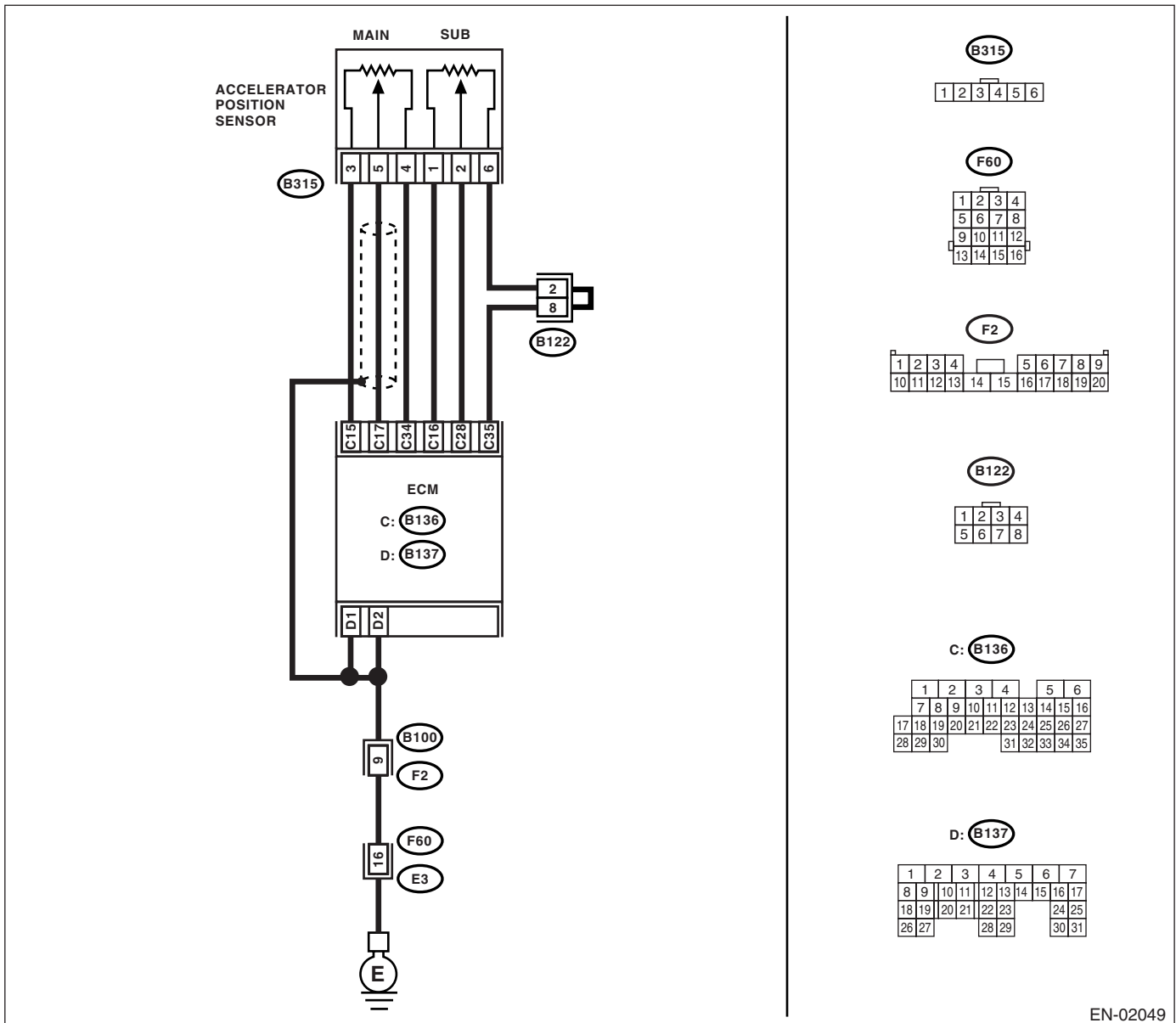

EN-02049

DIAGNOSTIC PROCEDURE WITH DIAGNOSTIC TROUBLE CODE (DTC)

ENGINE (DIAGNOSTICS)

Step	Check	Yes	No
1 CHECK OUTPUT VOLTAGE OF ACCELERATOR POSITION SENSOR. 1) Turn the ignition switch to ON. 2) Read the data of main accelerator position sensor signals, using Subaru Select Monitor. 3) Shake the ECM harness and connector, engine harness connector, accelerator position sensor connector harness while monitoring value of voltage meter.	Is the voltage less than 4.8 V?	Go to step 2.	Go to step 3.
2 CHECK POOR CONTACT IN CONNECTORS. Check poor contact in connectors between ECM and accelerator position sensor.	Is there any poor contact in connectors between ECM and accelerator position sensor?	Repair the poor contact in connectors.	Connector has returned to its normal condition at this time. A temporary poor contact in the connector might have been the cause.
3 CHECK HARNESS BETWEEN ECM AND ACCELERATOR POSITION SENSOR. 1) Turn the ignition switch to OFF. 2) Disconnect the connector from ECM. 3) Disconnect the connector from accelerator position sensor. 4) Measure the resistance between ECM connector and accelerator position sensor. Connector & terminal (B136) No. 34 — (B315) No. 4:	Is the resistance less than 1 Ω ?	Go to step 4.	Repair the open harness connector.
4 CHECK HARNESS BETWEEN ECM AND ACCELERATOR POSITION SENSOR. 1) Connect the ECM connector. 2) Measure the resistance between accelerator position sensor and engine ground. Connector & terminal (B315) No. 4 — Engine ground:	Is the resistance less than 5 Ω ?	Go to step 5.	Repair the poor contact in ECM connector. If problem persists, replace the ECM. <Ref. to FU(H4DOTC)-42, Engine Control Module (ECM).>
5 CHECK HARNESS BETWEEN ECM AND ACCELERATOR POSITION SENSOR. 1) Connect the ECM connector. 2) Turn the ignition switch to ON. 3) Measure the voltage between accelerator position sensor connector and engine ground. Connector & terminal (B315) No. 3 (+) — Engine ground (-): 4) Shake the ECM harness and connector, while monitoring value of voltage meter.	Is the voltage more than 6 V?	Go to step 6.	Repair the battery short of harness between ECM connector and accelerator position sensor.
6 CHECK POWER SUPPLY TO ACCELERATOR POSITION SENSOR. 1) Measure the voltage between accelerator position sensor connector and engine ground. Connector & terminal (B315) No. 5 (+) — Engine ground (-): 2) Shake the ECM harness and connector, while monitoring value of voltage meter.	Is the voltage less than 4.8 V?	Go to step 7.	Repair the short of harness between ECM connector and accelerator position sensor connector.

DIAGNOSTIC PROCEDURE WITH DIAGNOSTIC TROUBLE CODE (DTC)

ENGINE (DIAGNOSTICS)

Step	Check	Yes	No
<p>7</p> <p>CHECK HARNESS BETWEEN ECM AND ACCELERATOR POSITION SENSOR.</p> <p>1) Turn the ignition switch to OFF. 2) Connect the accelerator position sensor connector. 3) Turn the ignition switch to ON. 4) Measure the voltage between ECM connector and chassis ground.</p> <p>Connector & terminal (B136) No. 17 (+) — Chassis ground (-):</p>	Is the voltage 4.8 V?	Repair the poor contact in ECM connector. If problem persists, replace the ECM. <Ref. to FU(H4DOTC)-42, Engine Control Module (ECM).>	Repair the poor contact in electric throttle connector. If problem persists, replace the electric throttle.

DIAGNOSTIC PROCEDURE WITH DIAGNOSTIC TROUBLE CODE (DTC)

ENGINE (DIAGNOSTICS)

DW:DTC P2127 — THROTTLE/PEDAL POSITION SENSOR/SWITCH “E” CIRCUIT LOW INPUT —

DTC DETECTING CONDITION:

- Immediately at fault recognition
- GENERAL DESCRIPTION <Ref. to GD(H4DOTC)-272, DTC P2127 — THROTTLE/PEDAL POSITION SENSOR/SWITCH “E” CIRCUIT LOW INPUT —, Diagnostic Trouble Code (DTC) Detecting Criteria.>

TROUBLE SYMPTOM:

- Erroneous idling
- Poor driving performance

CAUTION:

After repair or replacement of faulty parts, conduct Clear Memory Mode <Ref. to EN(H4DOTC)-44, OPERATION, Clear Memory Mode.> and Inspection Mode <Ref. to EN(H4DOTC)-36, OPERATION, Inspection Mode.>.

WIRING DIAGRAM:

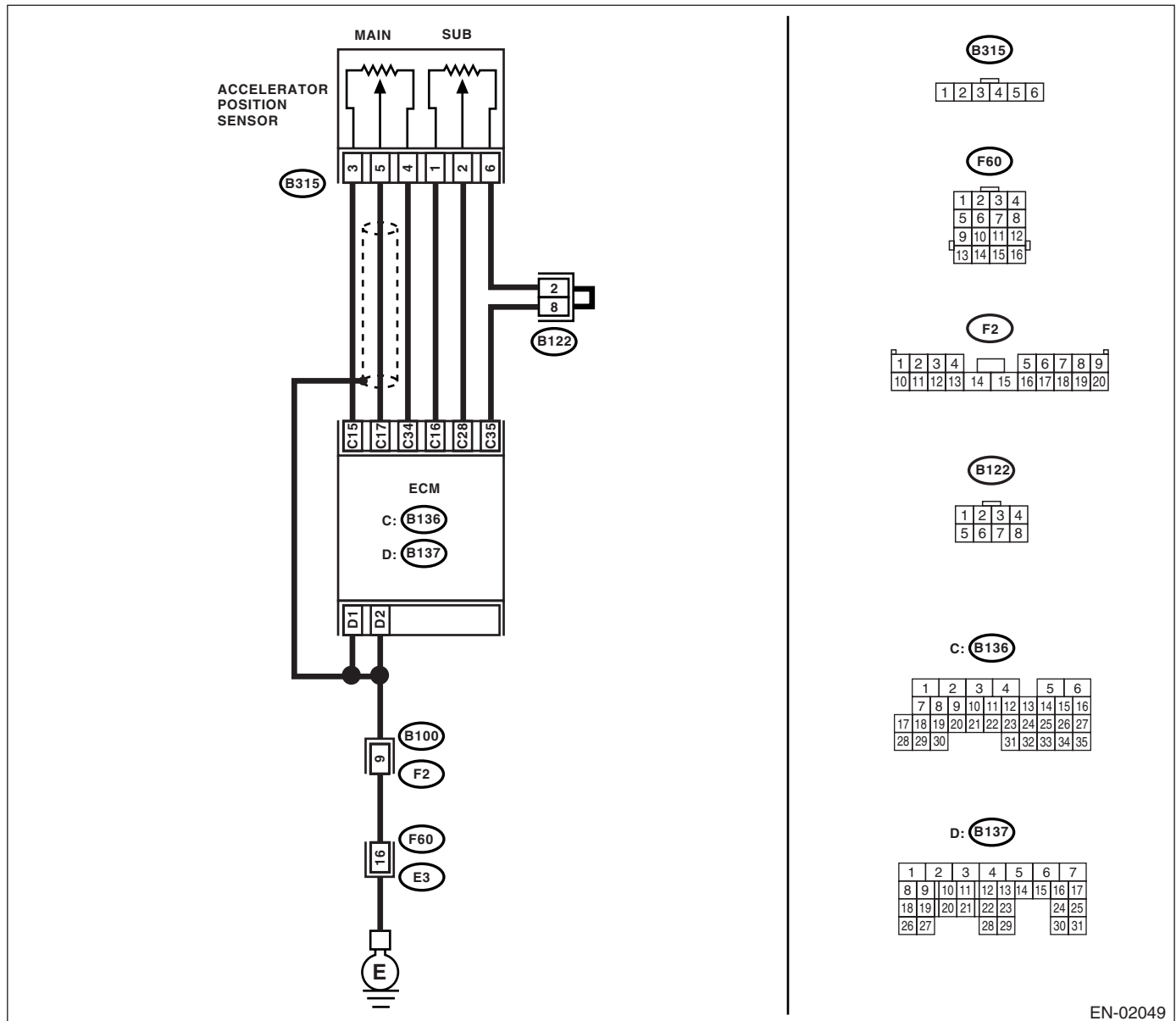

EN-02049

DIAGNOSTIC PROCEDURE WITH DIAGNOSTIC TROUBLE CODE (DTC)

ENGINE (DIAGNOSTICS)

Step	Check	Yes	No
<p>1</p> <p>CHECK OUTPUT VOLTAGE OF ACCELERATOR POSITION SENSOR. 1) Turn the ignition switch to ON. 2) Measure the voltage between ECM connector terminals. <i>Connector & terminal</i> <i>(B136) No. 28 (+) — (B136) No. 35 (-):</i> 3) Shake the ECM harness and connector, accelerator position sensor.</p>	Is the voltage more than 0.4 V?	Go to step 2.	Go to step 3.
<p>2</p> <p>CHECK POOR CONTACT IN CONNECTORS. Check poor contact in connectors between ECM and accelerator position sensor.</p>	Is there any poor contact in connectors between ECM and accelerator position sensor?	Repair the poor contact in connectors.	Connector has returned to its normal condition at this time. A temporary poor contact in the connector might have been the cause.
<p>3</p> <p>CHECK HARNESS BETWEEN ECM AND ACCELERATOR POSITION SENSOR. 1) Turn the ignition switch to OFF. 2) Disconnect the connector from ECM. 3) Disconnect the connector from accelerator position sensor. 4) Measure the resistance between ECM connector and accelerator position sensor. <i>Connector & terminal</i> <i>(B136) No. 28 — (B315) No. 2:</i> <i>(B136) No. 16 — (B315) No. 1:</i></p>	Is the resistance less than 1 Ω ?	Go to step 4.	Repair the open harness connector.
<p>4</p> <p>CHECK HARNESS BETWEEN ECM AND ACCELERATOR POSITION SENSOR. Measure the resistance between ECM connector and chassis ground. <i>Connector & terminal</i> <i>(B136) No. 28 — Chassis ground:</i> <i>(B136) No. 16 — Chassis ground:</i></p>	Is the resistance more than 1 M Ω ?	Go to step 5.	Repair the ground short of harness.
<p>5</p> <p>CHECK POWER SUPPLY TO ACCELERATOR POSITION SENSOR. 1) Connect the ECM connector. 2) Turn the ignition switch to ON. 3) Measure the voltage between accelerator position sensor connector and engine ground. <i>Connector & terminal</i> <i>(B315) No. 1 (+) — Engine ground (-):</i> 4) Shake the ECM harness and connector, while monitoring value of voltage meter.</p>	Is the voltage 4.5 — 5.5 V?	Go to step 6.	Repair the poor contact in ECM connector. If problem persists, replace the ECM. <Ref. to FU(H4DOTC)-42, Engine Control Module (ECM).>
<p>6</p> <p>CHECK ACCELERATOR POSITION SENSOR. Measure the resistance of accelerator position sensor. <i>Terminals</i> <i>No. 1 — No. 6:</i></p>	Is the resistance 0.75 — 3.15 k Ω ?	Go to step 7.	Replace the accelerator position sensor.
<p>7</p> <p>CHECK ACCELERATOR POSITION SENSOR. Measure the resistance of accelerator position sensor when accelerator pedal is released. <i>Terminals</i> <i>No. 2 — No. 6:</i></p>	Is the resistance 0.15 — 0.63 k Ω ?	Go to step 8.	Replace the accelerator position sensor.

DIAGNOSTIC PROCEDURE WITH DIAGNOSTIC TROUBLE CODE (DTC)

ENGINE (DIAGNOSTICS)

Step	Check	Yes	No
8 CHECK ACCELERATOR POSITION SENSOR. Measure the resistance of accelerator position sensor when acceleration pedal is being depressed. Terminals No. 2 — No. 6:	Is the resistance 0.28 — 1.68 k Ω ?	Repair the poor contact in ECM connector. If problem persists, replace the ECM.	Replace the accelerator position sensor.

DX:DTC P2128 — THROTTLE/PEDAL POSITION SENSOR/SWITCH “E” CIRCUIT HIGH INPUT —

DTC DETECTING CONDITION:

- Immediately at fault recognition
- GENERAL DESCRIPTION <Ref. to GD(H4DOTC)-274, DTC P2128 — THROTTLE/PEDAL POSITION SENSOR/SWITCH “E” CIRCUIT HIGH INPUT —, Diagnostic Trouble Code (DTC) Detecting Criteria.>

TROUBLE SYMPTOM:

- Erroneous idling
- Poor driving performance

CAUTION:

After repair or replacement of faulty parts, conduct Clear Memory Mode <Ref. to EN(H4DOTC)-44, OPERATION, Clear Memory Mode.> and Inspection Mode <Ref. to EN(H4DOTC)-36, OPERATION, Inspection Mode.>.

WIRING DIAGRAM:

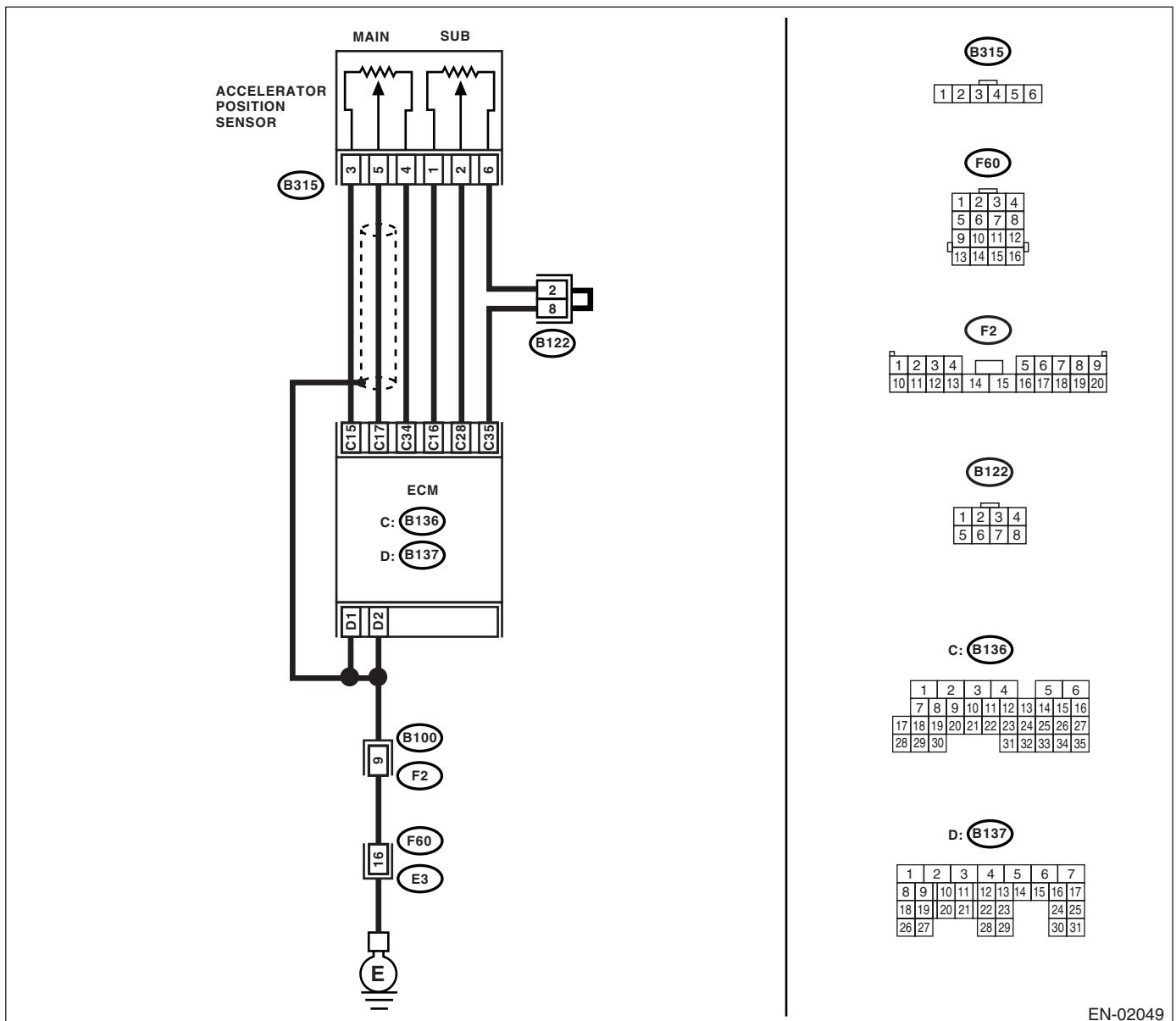

EN-02049

DIAGNOSTIC PROCEDURE WITH DIAGNOSTIC TROUBLE CODE (DTC)

ENGINE (DIAGNOSTICS)

Step	Check	Yes	No
1 CHECK OUTPUT VOLTAGE OF ACCELERATOR POSITION SENSOR. 1) Turn the ignition switch to ON. 2) Read the data of sub accelerator position sensor signals, using Subaru Select Monitor. 3) Shake the ECM harness and connector, engine harness connector, accelerator position sensor connector harness while monitoring value of voltage meter.	Is the voltage less than 4.8 V?	Go to step 2.	Go to step 3.
2 CHECK POOR CONTACT IN CONNECTORS. Check poor contact in connectors between ECM and accelerator position sensor.	Is there any poor contact in connectors between ECM and accelerator position sensor?	Repair the poor contact in connectors.	Connector has returned to its normal condition at this time. A temporary poor contact in the connector might have been the cause.
3 CHECK HARNESS BETWEEN ECM AND ACCELERATOR POSITION SENSOR. 1) Turn the ignition switch to OFF. 2) Disconnect the connector from ECM. 3) Disconnect the connector from accelerator position sensor. 4) Measure the resistance between ECM connector and accelerator position sensor. Connector & terminal (B136) No. 35 — (B315) No. 6:	Is the resistance less than 1 Ω ?	Go to step 4.	Repair the open harness connector.
4 CHECK HARNESS BETWEEN ECM AND ACCELERATOR POSITION SENSOR. 1) Connect the ECM connector. 2) Measure the resistance between accelerator position sensor connector and engine ground. Connector & terminal (B315) No. 6 — Engine ground:	Is the resistance less than 5 Ω ?	Go to step 5.	Repair the poor contact in ECM connector. If problem persists, replace the ECM.
5 CHECK HARNESS BETWEEN ECM AND ACCELERATOR POSITION SENSOR. 1) Connect the ECM connector. 2) Turn the ignition switch to ON. 3) Measure the voltage between accelerator position sensor connector and engine ground. Connector & terminal (B315) No. 1 (+) — Engine ground (-): 4) Shake the ECM harness and connector, while monitoring value of voltage meter.	Is the voltage less than 6 V?	Go to step 6.	Repair the battery short of harness between ECM connector and accelerator position sensor connector.
6 CHECK POWER SUPPLY TO ACCELERATOR POSITION SENSOR. 1) Measure the voltage between accelerator position sensor connector and engine ground. Connector & terminal (B315) No. 2 (+) — Engine ground (-): 2) Shake the ECM harness and connector, while monitoring value of voltage meter.	Is the voltage less than 4.8 V?	Go to step 7.	Repair the short of harness between ECM connector and accelerator position sensor connector.

DIAGNOSTIC PROCEDURE WITH DIAGNOSTIC TROUBLE CODE (DTC)

ENGINE (DIAGNOSTICS)

Step	Check	Yes	No
<p>7</p> <p>CHECK HARNESS BETWEEN ECM AND ACCELERATOR POSITION SENSOR.</p> <p>1) Turn the ignition switch to OFF. 2) Connect the accelerator position sensor connector. 3) Turn the ignition switch to ON. 4) Measure the voltage between ECM connector and chassis ground.</p> <p>Connector & terminal (B136) No. 16 (+) — Chassis ground (-):</p>	<p>Is the voltage 4.8 V?</p>	<p>Repair the poor contact in ECM connector. If problem persists, replace the ECM. <Ref. to FU(H4DOTC)-42, Engine Control Module (ECM).></p>	<p>Repair the poor contact in electric throttle connector. If problem persists, replace the electric throttle.</p>

DIAGNOSTIC PROCEDURE WITH DIAGNOSTIC TROUBLE CODE (DTC)

ENGINE (DIAGNOSTICS)

DY:DTC P2135 — THROTTLE/PEDAL POSITION SENSOR/SWITCH “A”/“B” VOLTAGE RATIONALITY —

DTC DETECTING CONDITION:

- Immediately at fault recognition
- GENERAL DESCRIPTION <Ref. to GD(H4DOTC)-276, DTC P2135 — THROTTLE/PEDAL POSITION SENSOR/SWITCH “A” / “B” VOLTAGE RATIONALITY —, Diagnostic Trouble Code (DTC) Detecting Criteria.>

TROUBLE SYMPTOM:

- Erroneous idling
- Poor driving performance

CAUTION:

After repair or replacement of faulty parts, conduct Clear Memory Mode <Ref. to EN(H4DOTC)-44, OPERATION, Clear Memory Mode.> and Inspection Mode <Ref. to EN(H4DOTC)-36, OPERATION, Inspection Mode.>.

DIAGNOSTIC PROCEDURE WITH DIAGNOSTIC TROUBLE CODE (DTC) ENGINE (DIAGNOSTICS)

WIRING DIAGRAM:

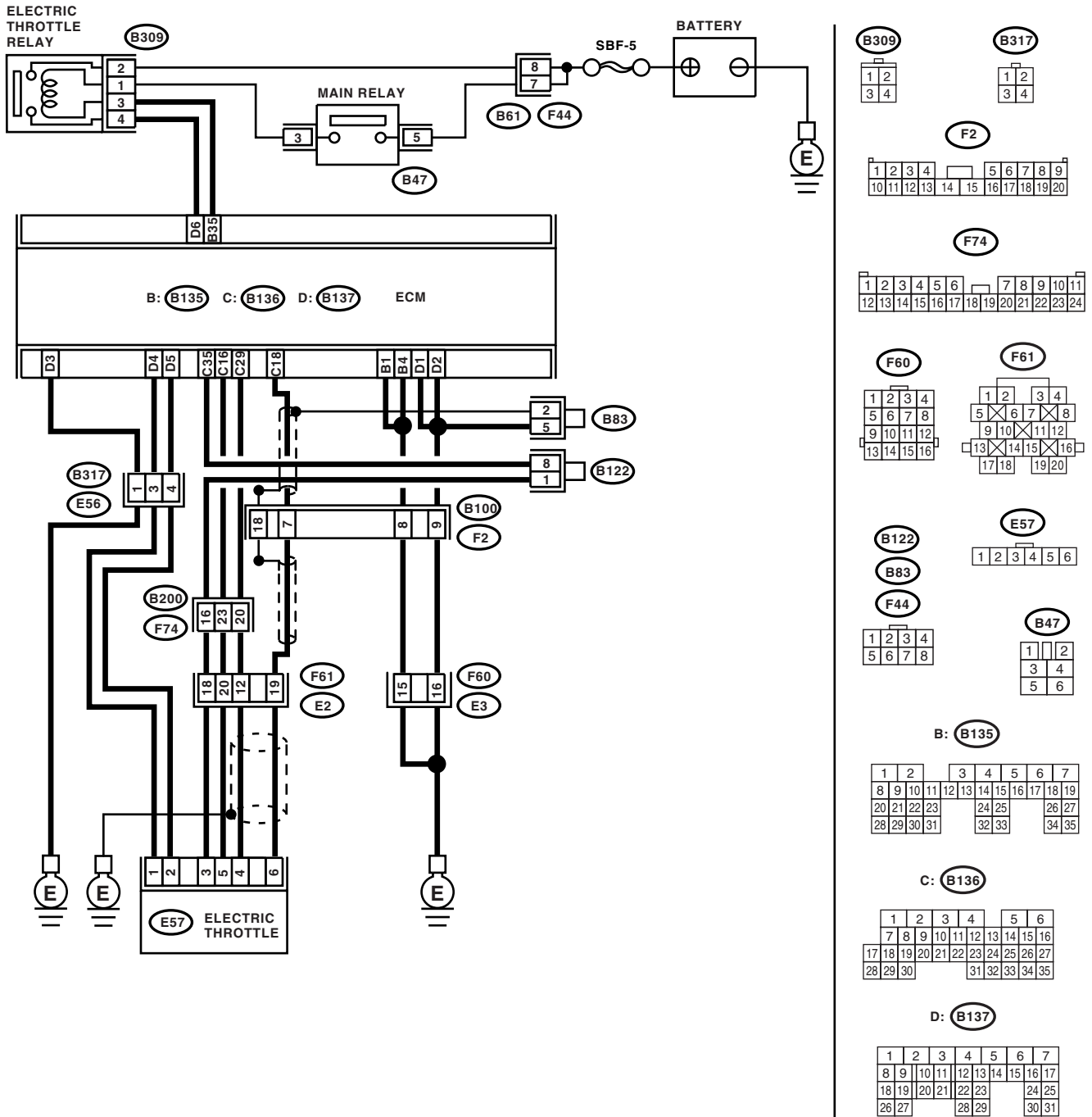

EN-02025

DIAGNOSTIC PROCEDURE WITH DIAGNOSTIC TROUBLE CODE (DTC)

ENGINE (DIAGNOSTICS)

Step	Check	Yes	No
1 CHECK OUTPUT VOLTAGE OF ACCELERATOR POSITION SENSOR. 1) Turn the ignition switch to ON. 2) Measure the voltage between ECM connector terminals. <i>Connector & terminal</i> <i>(B136) No. 18 (+) — (B136) No. 35 (-):</i> 3) Shake the ECM harness and connector, engine harness connectors, electric throttle connector harness while monitoring value of voltage meter.	Is the voltage more than 0.4 V?	Go to step 2.	Go to step 4.
2 CHECK OUTPUT VOLTAGE OF ACCELERATOR POSITION SENSOR. 1) Measure the voltage between ECM connector terminals. <i>Connector & terminal</i> <i>(B136) No. 29 (+) — (B136) No. 35 (-):</i> 2) Shake the ECM harness and connector, engine harness connectors, electric throttle connector harness while monitoring value of voltage meter.	Is the voltage more than 0.8 V?	Go to step 3.	Go to step 4.
3 CHECK POOR CONTACT IN CONNECTORS. Check poor contact in connectors between ECM and electric throttle.	Is there any poor contact in connectors between ECM and electric throttle?	Repair the poor contact in connectors.	Go to step 14.
4 CHECK HARNESS BETWEEN ECM AND ELECTRIC THROTTLE. 1) Turn the ignition switch to OFF. 2) Disconnect the connector from ECM. 3) Disconnect the connector from electric throttle. 4) Measure the resistance between ECM connector and electric throttle connector. <i>Connector & terminal</i> <i>(B136) No. 16 — (E57) No. 5:</i>	Is the resistance less than 1 Ω ?	Go to step 5.	Repair the open harness connector.
5 CHECK HARNESS BETWEEN ECM AND ELECTRIC THROTTLE. Measure the resistance between ECM connector and chassis ground. <i>Connector & terminal</i> <i>(B136) No. 18 — Chassis ground:</i> <i>(B136) No. 29 — Chassis ground:</i> <i>(B136) No. 16 — Chassis ground:</i>	Is the resistance more than 1 M Ω ?	Go to step 6.	Repair the ground short of harness.
6 CHECK POWER SUPPLY TO SENSOR. 1) Connect the ECM connector. 2) Turn the ignition switch to ON. 3) Measure the voltage between electric throttle connector and engine ground. <i>Connector & terminal</i> <i>(E57) No. 5 (+) — Engine ground (-):</i> 4) Shake the ECM harness and connector, engine harness connectors, while monitoring value of voltage meter.	Is the voltage 4.5 — 5.5 V?	Go to step 7.	Repair the poor contact in ECM connector. If problem persists, replace the ECM.

DIAGNOSTIC PROCEDURE WITH DIAGNOSTIC TROUBLE CODE (DTC)

ENGINE (DIAGNOSTICS)

Step	Check	Yes	No
7 CHECK SHORT OF ECM. 1) Turn the ignition switch to OFF. 2) Measure the resistance between electric throttle connector and engine ground. Connector & terminal (E57) No. 6 — Engine ground: (E57) No. 4 — Engine ground:	Is the resistance more than 10 Ω?	Go to step 8.	Repair the poor contact in ECM connector. If problem persists, replace the ECM. <Ref. to FU(H4DOTC)-42, Engine Control Module (ECM).>
8 CHECK OUTPUT VOLTAGE OF ACCELERATOR POSITION SENSOR. 1) Connect all the connectors. 2) Turn the ignition switch to ON. 3) Read the data of main throttle sensor signals, using Subaru Select Monitors. 4) Shake the ECM harness and connector, engine harness connector, electric throttle connector harness while monitoring value of voltage meter.	Is the voltage less than 4.63 V?	Go to step 9.	Go to step 11.
9 CHECK OUTPUT VOLTAGE OF ACCELERATOR POSITION SENSOR. 1) Read the data of sub throttle sensor signals, using Subaru Select Monitors. 2) Shake the ECM harness and connector, engine harness connector, electric throttle connector harness while monitoring value of voltage meter.	Is the voltage less than 4.73 V?	Go to step 10.	Go to step 11.
10 CHECK POOR CONTACT IN CONNECTORS. Check poor contact in connectors between ECM and electric throttle.	Is there any poor contact in connectors between ECM and electric throttle?	Repair the poor contact in connectors.	Connector has returned to a normal condition at this time. A temporary poor contact in the connector might have been the cause.
11 CHECK HARNESS BETWEEN ECM AND ELECTRIC THROTTLE. 1) Turn the ignition switch to OFF. 2) Disconnect the connector from ECM. 3) Disconnect the connector from electric throttle. 4) Measure the resistance between ECM connector and electric throttle connector. Connector & terminal (B136) No. 35 — (E57) No. 3: (B136) No. 18 — (E57) No. 6: (B136) No. 29 — (E57) No. 4:	Is the resistance less than 1 Ω?	Go to step 12.	Repair the open harness connector.
12 CHECK HARNESS BETWEEN ECM AND ELECTRIC THROTTLE. 1) Connect the ECM connector. 2) Measure the resistance between electric throttle connector and engine ground. Connector & terminal (E57) No. 3 — Engine ground:	Is the resistance less than 5 Ω?	Go to step 13.	Repair the poor contact in ECM connector. If problem persists, replace the ECM.

DIAGNOSTIC PROCEDURE WITH DIAGNOSTIC TROUBLE CODE (DTC)

ENGINE (DIAGNOSTICS)

Step	Check	Yes	No
<p>13 CHECK HARNESS BETWEEN ECM AND ELECTRIC THROTTLE.</p> <p>1) Connect the ECM connector. 2) Turn the ignition switch to ON. 3) Measure the voltage between electric throttle connector and engine ground.</p> <p>Connector & terminal (E57) No. 5 (+) — Engine ground (-):</p> <p>4) Shake the ECM harness and connector, engine harness connectors, while monitoring value of voltage meter.</p>	Is the voltage more than 10 V?	Go to step 14.	Repair the battery short of harness between ECM connector and electric throttle connector.
<p>14 CHECK HARNESS BETWEEN ECM AND ELECTRIC THROTTLE.</p> <p>1) Measure the voltage between electric throttle connector and engine ground.</p> <p>Connector & terminal (E57) No. 6 (+) — Engine ground (-): (E57) No. 4 (+) — Engine ground (-):</p> <p>2) Shake the ECM harness and connector, engine harness connectors, while monitoring value of voltage meter.</p>	Is the voltage less than 10 V?	Go to step 15.	Repair the short of harness between ECM connector and electric throttle connector.
<p>15 CHECK HARNESS BETWEEN ECM AND ELECTRIC THROTTLE.</p> <p>1) Turn the ignition switch to OFF. 2) Disconnect the electric throttle connector. 3) Measure the resistance between ECM connectors.</p> <p>Connector & terminal (B136) No. 18 — (B136) No. 35: (B136) No. 29 — (B136) No. 35:</p>	Is the resistance more than 1 M Ω ?	Go to step 16.	Repair the short of power supply sensor.
<p>16 CHECK ELECTRIC THROTTLE HARNESS.</p> <p>1) Disconnect the connector from ECM. 2) Disconnect the connector from electric throttle. 3) Measure the resistance between electric throttle connector terminals.</p> <p>Connector & terminal (E57) No. 6 — (E57) No. 4:</p>	Is the resistance more than 1 M Ω ?	Repair the poor contact in ECM connector. If problem persists, replace the ECM.	Repair the short of harness.

DIAGNOSTIC PROCEDURE WITH DIAGNOSTIC TROUBLE CODE (DTC)

ENGINE (DIAGNOSTICS)

DZ:DTC P2138 — THROTTLE/PEDAL POSITION SENSOR/SWITCH “D”/“E” VOLTAGE RATIONALITY —

DTC DETECTING CONDITION:

- Immediately at fault recognition
- GENERAL DESCRIPTION <Ref. to GD(H4DOTC)-278, DTC P2138 — THROTTLE/PEDAL POSITION SENSOR/SWITCH “D” / “E” VOLTAGE RATIONALITY —, Diagnostic Trouble Code (DTC) Detecting Criteria.>

TROUBLE SYMPTOM:

- Erroneous idling
- Poor driving performance

CAUTION:

After repair or replacement of faulty parts, conduct Clear Memory Mode <Ref. to EN(H4DOTC)-44, OPERATION, Clear Memory Mode.> and Inspection Mode <Ref. to EN(H4DOTC)-36, OPERATION, Inspection Mode.>.

WIRING DIAGRAM:

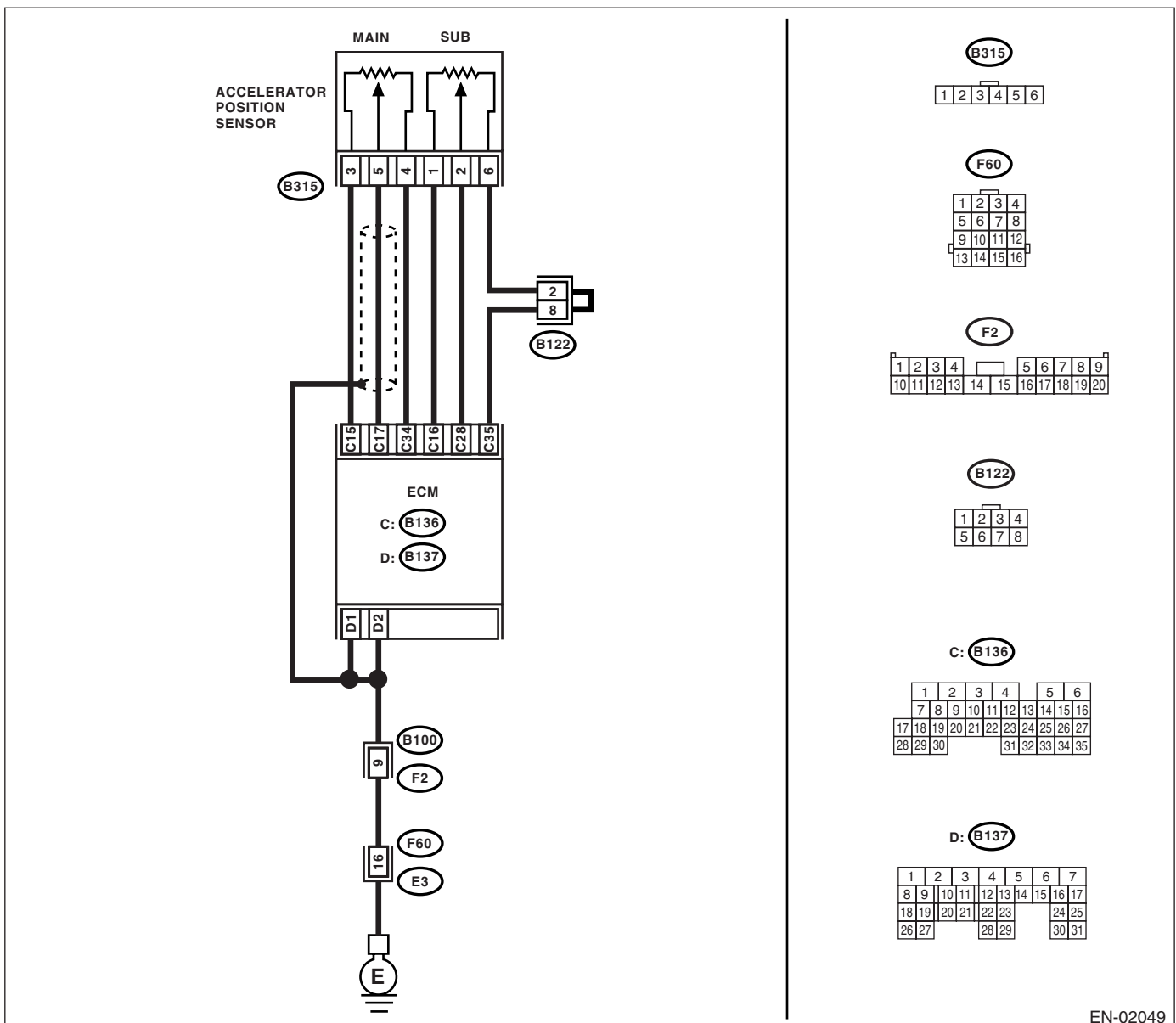

EN-02049

DIAGNOSTIC PROCEDURE WITH DIAGNOSTIC TROUBLE CODE (DTC)

ENGINE (DIAGNOSTICS)

Step	Check	Yes	No
<p>1 CHECK OUTPUT VOLTAGE OF ACCELERATOR POSITION SENSOR.</p> <p>1) Turn the ignition switch to ON. 2) Measure the voltage between ECM connector terminals.</p> <p>Connector & terminal (B136) No. 17 (+) — (B136) No. 34 (-): (B136) No. 28 (+) — (B136) No. 35 (-):</p> <p>3) Shake the ECM harness and connector, accelerator position sensor connector and harness.</p>	Is the voltage more than 0.4 V?	Go to step 2.	Go to step 3.
<p>2 CHECK POOR CONTACT IN CONNECTORS.</p> <p>Check poor contact in connectors between ECM and electric throttle.</p>	Is there any poor contact in connectors between ECM and electric throttle?	Repair the poor contact in connectors.	Go to step 9.
<p>3 CHECK HARNESS BETWEEN ECM AND ACCELERATOR POSITION SENSOR.</p> <p>1) Turn the ignition switch to OFF. 2) Disconnect the connector from ECM. 3) Disconnect the connector from accelerator position sensor. 4) Measure the resistance between ECM connector and accelerator position sensor connector.</p> <p>Connector & terminal (B136) No. 17 — (B315) No. 5: (B136) No. 15 — (B315) No. 3: (B136) No. 28 — (B315) No. 2: (B136) No. 16 — (B315) No. 1:</p>	Is the resistance less than 1 Ω ?	Go to step 4.	Repair the open harness connector.
<p>4 CHECK HARNESS BETWEEN ECM AND ACCELERATOR POSITION SENSOR.</p> <p>Measure the resistance between ECM connector and chassis ground.</p> <p>Connector & terminal (B136) No. 17 — Chassis ground: (B136) No. 15 — Chassis ground: (B136) No. 28 — Chassis ground: (B136) No. 16 — Chassis ground:</p>	Is the resistance more than 1 M Ω ?	Go to step 5.	Repair the ground short of harness.
<p>5 CHECK POWER SUPPLY TO ACCELERATOR POSITION SENSOR.</p> <p>1) Connect the ECM connector. 2) Turn the ignition switch to ON. 3) Measure the voltage between accelerator position sensor connector and engine ground.</p> <p>Connector & terminal (B315) No. 3 (+) — Engine ground (-): (B315) No. 1 (+) — Engine ground (-):</p> <p>4) Shake the ECM harness and connector, while monitoring value of voltage meter.</p>	Is the voltage 4.5 — 5.5 V?	Go to step 6.	Repair the poor contact in ECM connector. If problem persists, replace the ECM.
<p>6 CHECK ACCELERATOR POSITION SENSOR.</p> <p>Measure the resistance of accelerator position sensor.</p> <p>Terminals No. 3 — No. 4:</p>	Is the resistance 1.2 — 4.8 k Ω ?	Go to step 7.	Replace the accelerator position sensor.

DIAGNOSTIC PROCEDURE WITH DIAGNOSTIC TROUBLE CODE (DTC)

ENGINE (DIAGNOSTICS)

Step	Check	Yes	No	
7	CHECK ACCELERATOR POSITION SENSOR. Measure the resistance of accelerator position sensor. <i>Terminals</i> <i>No. 1 — No. 6:</i>	Is the resistance 0.75 — 3.15 kΩ?	Go to step 8.	Replace the accelerator position sensor.
8	CHECK ACCELERATOR POSITION SENSOR. Measure the resistance of accelerator position sensor when the acceleration pedal is released. <i>Terminals</i> <i>No. 5 — No. 4:</i>	Is the resistance 0.2 — 0.8 kΩ?	Go to step 9.	Replace the accelerator position sensor.
9	CHECK ACCELERATOR POSITION SENSOR. Measure the resistance of accelerator position sensor when the acceleration pedal is released. <i>Connector & terminal</i> <i>No. 2 — No. 6:</i>	Is the resistance 0.15 — 0.63 kΩ?	Go to step 10.	Replace the accelerator position sensor.
10	CHECK ACCELERATOR POSITION SENSOR. Measure the resistance of accelerator position sensor when the acceleration pedal is being depressed. <i>Terminals</i> <i>No. 5 — No. 4:</i>	Is the resistance 0.5 — 2.5 kΩ?	Go to step 11.	Replace the accelerator position sensor.
11	CHECK ACCELERATOR POSITION SENSOR. Measure the resistance of accelerator position sensor when the acceleration pedal is being depressed. <i>Terminals</i> <i>No. 2 — No. 6:</i>	Is the resistance 0.28 — 1.68 kΩ?	Go to step 12.	Replace the accelerator position sensor.
12	CHECK OUTPUT VOLTAGE OF ACCELERATOR POSITION SENSOR. 1) Turn the ignition switch to OFF. 2) Connect all the connectors. 3) Turn the ignition switch to ON. 4) Read the data of main accelerator position sensor signals and sub accelerator position sensor signals, using Subaru Select Monitor. 5) Shake the ECM harness and connector, engine harness connector, accelerator position sensor connector harness while monitoring value of voltage meter.	Is the voltage less than 4.8 V?	Go to step 13.	Go to step 14.
13	CHECK POOR CONTACT IN CONNECTORS. Check poor contact in connectors between ECM and electric throttle.	Is there any poor contact in connectors between ECM and electric throttle?	Repair the poor contact in connectors.	Go to step 19.

DIAGNOSTIC PROCEDURE WITH DIAGNOSTIC TROUBLE CODE (DTC)

ENGINE (DIAGNOSTICS)

Step	Check	Yes	No
14 CHECK HARNESS BETWEEN ECM AND ACCELERATOR POSITION SENSOR. 1) Turn the ignition switch to OFF. 2) Disconnect the connector from ECM. 3) Disconnect the connector from accelerator position sensor. 4) Measure the resistance between ECM connector and accelerator position sensor connector. <i>Connector & terminal</i> <i>(B136) No. 34 — (B315) No. 4:</i> <i>(B136) No. 35 — (B315) No. 6:</i>	Is the resistance less than 1 Ω ?	Go to step 15.	Repair the open harness connector.
15 CHECK HARNESS BETWEEN ECM AND ACCELERATOR POSITION SENSOR. 1) Connect the ECM connector. 2) Measure the resistance between accelerator position sensor and engine ground. <i>Connector & terminal</i> <i>(B315) No. 4 — Engine ground:</i> <i>(B315) No. 6 — Engine ground:</i>	Is the resistance less than 5 Ω ?	Go to step 16.	Repair the poor contact in ECM connector. If problem persists, replace the ECM.
16 CHECK HARNESS BETWEEN ECM AND ACCELERATOR POSITION SENSOR. 1) Connect the ECM connector. 2) Turn the ignition switch to ON. 3) Measure the voltage between accelerator position sensor and engine ground. <i>Connector & terminal</i> <i>(B315) No. 3 (+) — Engine ground (-):</i> <i>(B315) No. 1 (+) — Engine ground (-):</i> 4) Shake the ECM harness and connector, while monitoring value of voltage meter.	Is the voltage less than 6 V?	Go to step 17.	Repair the battery short of harness between ECM connector and accelerator position sensor.
17 CHECK POWER SUPPLY TO ACCELERATOR POSITION SENSOR. 1) Measure the voltage between accelerator position sensor connector and engine ground. <i>Connector & terminal</i> <i>(B315) No. 5 (+) — Engine ground (-):</i> <i>(B315) No. 2 (+) — Engine ground (-):</i> 2) Shake the ECM harness and connector, while monitoring value of voltage meter.	Is the voltage less than 4.8 V?	Go to step 18.	Repair the short of harness between ECM connector and accelerator position sensor connector.
18 CHECK HARNESS BETWEEN ECM AND ACCELERATOR POSITION SENSOR. 1) Turn the ignition switch to OFF. 2) Connect the accelerator position sensor connector. 3) Turn the ignition switch to ON. 4) Measure the voltage between ECM connector and chassis ground. <i>Connector & terminal</i> <i>(B136) No. 17 (+) — Chassis ground (-):</i> <i>(B136) No. 28 (+) — Chassis ground (-):</i>	Is the voltage less than 4.8 V?	Go to step 19.	Repair the poor contact in accelerator position sensor connector. If problem persists, replace the accelerator position sensor.

DIAGNOSTIC PROCEDURE WITH DIAGNOSTIC TROUBLE CODE (DTC)

ENGINE (DIAGNOSTICS)

Step	Check	Yes	No
<p>19 CHECK HARNESS BETWEEN ECM AND ACCELERATOR POSITION SENSOR. 1) Turn the ignition switch to OFF. 2) Disconnect the connector from ECM. 3) Disconnect the connector from accelerator position sensor. 4) Measure the resistance between terminals of accelerator position sensor connector. Connector & terminal (B315) No. 5 — (B315) No. 2:</p>	<p>Is the resistance less than 1 MΩ?</p>	<p>Repair the poor contact in ECM connector. If problem persists, replace the ECM.</p>	<p>Repair the short of harness between accelerator position sensor connector and accelerator position sensor connector.</p>