

30. Fuel Delivery, Return and Evaporation Lines

A: REMOVAL

- 1) Set the vehicle on a lift.
- 2) Release the fuel pressure. <Ref. to FU(H4DOTC)-46, RELEASING OF FUEL PRESSURE, OPERATION, Fuel.>
- 3) Open the fuel filler flap lid and remove the fuel filler cap.
- 4) Remove the floor mat. <Ref. to EI-46, REMOVAL, Floor Mat.>
- 5) Remove the fuel delivery pipes and hoses, fuel return pipes and hoses, evaporation pipes and hoses.

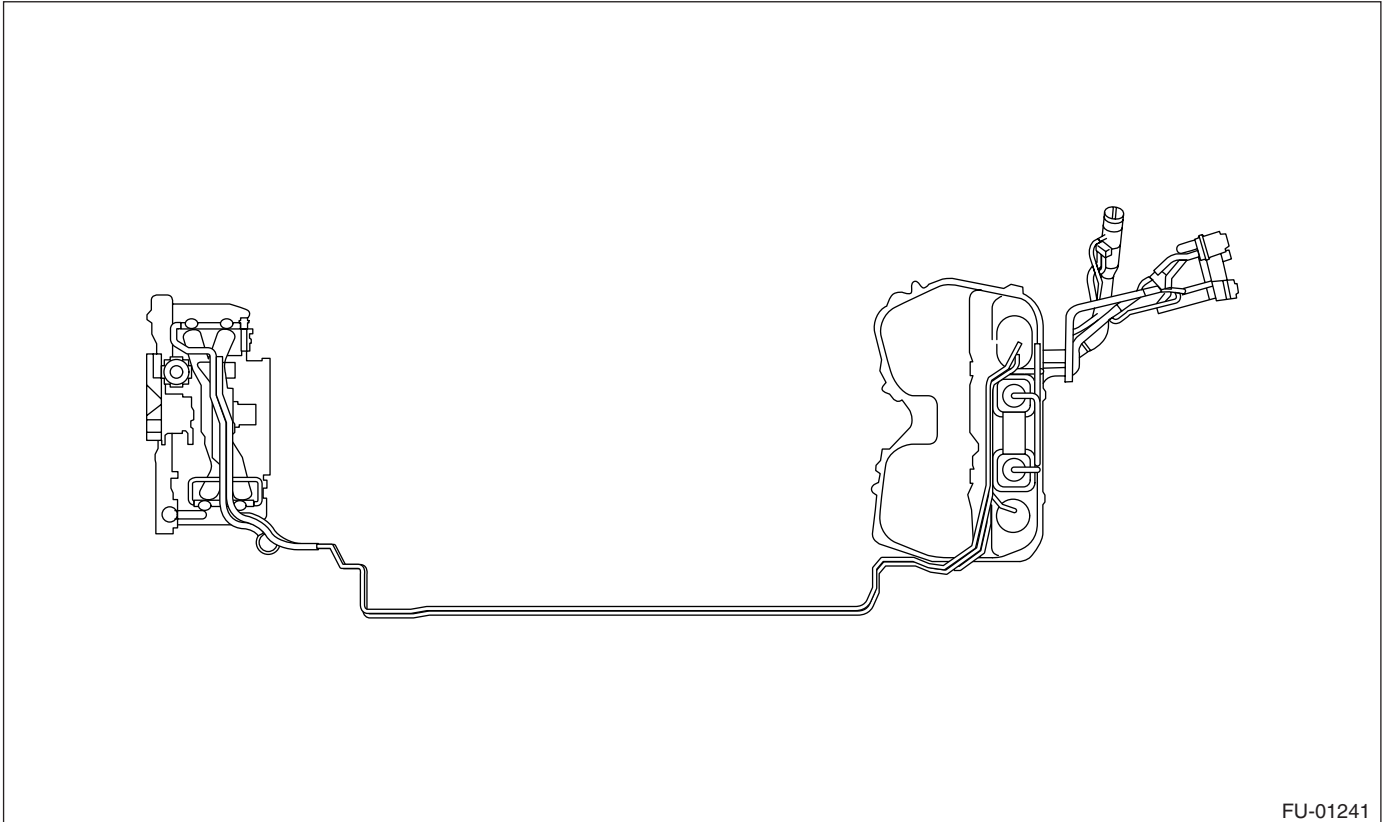

FU-01241

FUEL DELIVERY, RETURN AND EVAPORATION LINES

FUEL INJECTION (FUEL SYSTEMS)

6) In engine compartment, detach the fuel delivery hose (A), return hose (B) and evaporation hose (C).

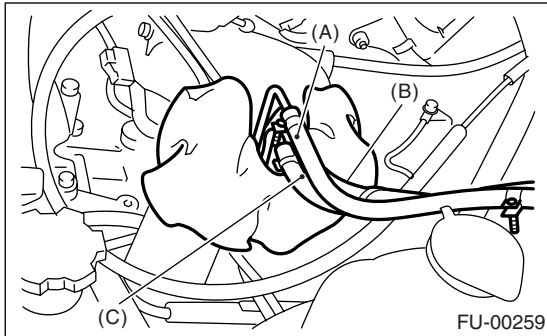

7) Lift-up the vehicle.

8) Separate the quick connector on the fuel delivery line.

(1) Clean the pipe and connector, if they are covered with dust.

(2) Hold the connector (A) and push retainer (B) down.

(3) Pull out the connector (A) from retainer (B).

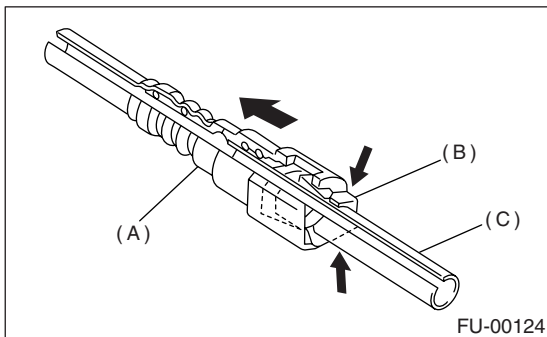

- (A) Connector
- (B) Retainer
- (C) Pipe

B: INSTALLATION

1) Connect the quick connector on the fuel delivery line.

NOTE:

- Always use a new retainer.
- Make sure that the connected portion is not damaged or has no dust. If necessary, clean seal surface of pipe.

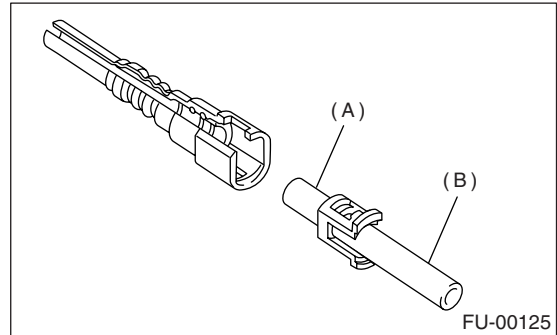

- (A) Seal surface
- (B) Pipe

(1) Set a new retainer (B) to connector (A).

(2) Push the pipe into the connector completely.

NOTE:

At this time, two clicking sounds are heard.

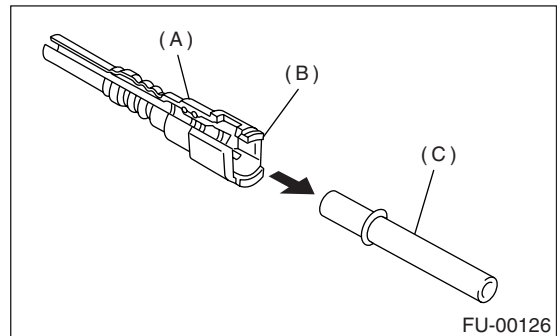

- (A) Connector
- (B) Retainer
- (C) Pipe

FUEL DELIVERY, RETURN AND EVAPORATION LINES

FUEL INJECTION (FUEL SYSTEMS)

CAUTION:

- Pull the connector to ensure it is connected securely.
- Ensure the two retainer pawls are engaged in their mating positions in the connector.
- Be sure to inspect hoses and their connections for any leakage of fuel.

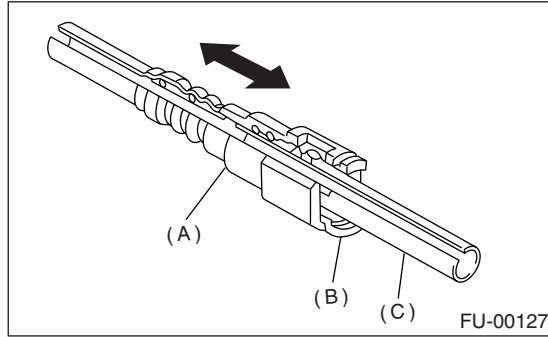

- (A) Connector
- (B) Retainer
- (C) Pipe

2) Connect the fuel delivery hose and return hose to the pipe with an overlap of 20 to 25 mm (0.79 to 0.98 in).

Type A: When the fitting length is specified.

Type B: When the fitting length is not specified.

$\varnothing : 2.5 \pm 1.5 \text{ mm } (0.098 \pm 0.059 \text{ in})$

$L : 22.5 \pm 2.5 \text{ mm } (0.886 \pm 0.098 \text{ in})$

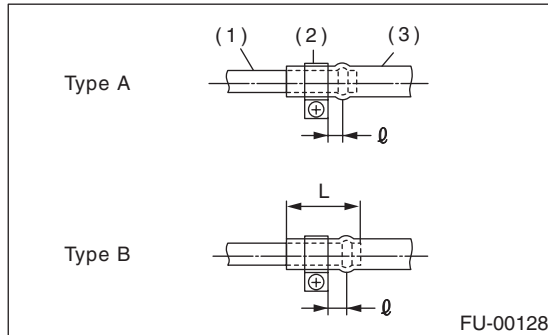

- (1) Pipe
- (2) Clamp
- (3) Hose

3) Connect the evaporation hose to the pipe with an overlap of 15 to 20 mm (0.59 to 0.79 in).

$L : 17.5 \pm 2.5 \text{ mm } (0.689 \pm 0.098 \text{ in})$

CAUTION:

Be sure to inspect hoses and their connections for any leakage of fuel.

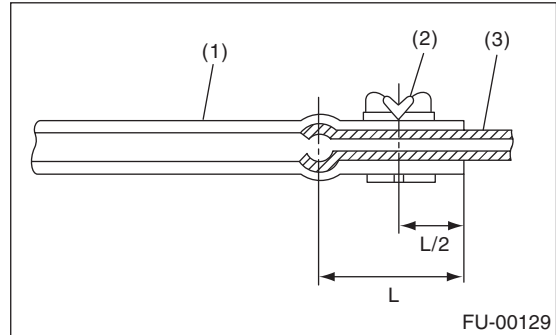

- (1) Hose
- (2) Clip
- (3) Pipe

C: INSPECTION

1) Make sure there are no cracks on the fuel pipes and fuel hoses.

2) Make sure the fuel pipe and fuel hose connections are tightened firmly.