

CRANK SPROCKET

MECHANICAL

17. Crank Sprocket

A: REMOVAL

- 1) Remove the V-belt. <Ref. to ME(H4DOTC)-45, REMOVAL, V-belt.>
- 2) Remove the crank pulley. <Ref. to ME(H4DOTC)-48, REMOVAL, Crank Pulley.>
- 3) Remove the timing belt cover. <Ref. to ME(H4DOTC)-49, REMOVAL, Timing Belt Cover.>
- 4) Remove the timing belt assembly. <Ref. to ME(H4DOTC)-50, REMOVAL, Timing Belt Assembly.>
- 5) Remove the cam sprocket. <Ref. to ME(H4DOTC)-58, REMOVAL, Cam Sprocket.>
- 6) Remove the crank sprocket.

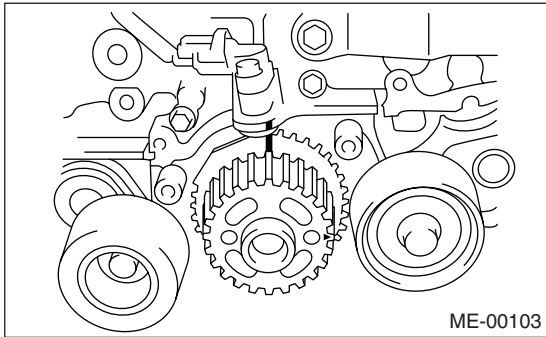

B: INSTALLATION

- 1) Install the crank sprocket.

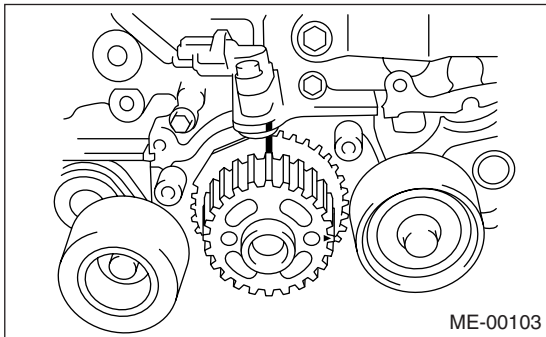

- 2) Install the cam sprocket. <Ref. to ME(H4DOTC)-58, INSTALLATION, Cam Sprocket.>
- 3) Install the timing belt assembly. <Ref. to ME(H4DOTC)-52, INSTALLATION, Timing Belt Assembly.>
- 4) Install the timing belt cover. <Ref. to ME(H4DOTC)-49, INSTALLATION, Timing Belt Cover.>
- 5) Install the crank pulley. <Ref. to ME(H4DOTC)-48, INSTALLATION, Crank Pulley.>
- 6) Install the V-belt. <Ref. to ME(H4DOTC)-45, INSTALLATION, V-belt.>

C: INSPECTION

- 1) Check the sprocket teeth for abnormal wear and scratches.
- 2) Make sure there is no free play between sprocket and key.
- 3) Check the crank sprocket notch used for sensor for damage and contamination of foreign matter.