

DIAGNOSTICS FOR ENGINE STARTING FAILURE

ENGINE (DIAGNOSTICS)

17. Diagnostics for Engine Starting Failure

A: PROCEDURE

1. Inspection of starter motor circuit. <Ref. to EN(H4SO)-63, STARTER MOTOR CIRCUIT, Diagnostics for Engine Starting Failure.>
↓
2. Inspection of ECM power supply and ground line. <Ref. to EN(H4SO)-66, CONTROL MODULE POWER SUPPLY AND GROUND LINE, Diagnostics for Engine Starting Failure.>
↓
3. Inspection of ignition control system. <Ref. to EN(H4SO)-69, IGNITION CONTROL SYSTEM, Diagnostics for Engine Starting Failure.>
↓
4. Inspection of fuel pump circuit. <Ref. to EN(H4SO)-72, FUEL PUMP CIRCUIT, Diagnostics for Engine Starting Failure.>
↓
5. Inspection of fuel injector circuit. <Ref. to EN(H4SO)-75, FUEL INJECTOR CIRCUIT, Diagnostics for Engine Starting Failure.>

DIAGNOSTICS FOR ENGINE STARTING FAILURE

ENGINE (DIAGNOSTICS)

Step	Check	Yes	No
1 CHECK BATTERY. Check the battery voltage.	Is the voltage more than 12 V?	Go to step 2.	Charge or replace the battery.
2 CHECK INPUT SIGNAL FOR STARTER MOTOR. 1) Turn the ignition switch to OFF. 2) Disconnect the connector from starter motor. 3) Turn the ignition switch to ST. 4) Measure the power supply voltage between starter motor connector terminal and engine ground. Connector & terminal (B14) No. 1 (+) — Engine ground (-): NOTE: • On AT model, place the select lever in the “P” or “N” range. • On MT model, depress the clutch pedal.	Is the voltage more than 10 V?	Go to step 3.	Go to step 4.
3 CHECK GROUND CIRCUIT OF STARTER MOTOR. 1) Turn the ignition switch to OFF. 2) Disconnect the terminal from starter motor. 3) Measure the resistance of ground cable between ground cable terminal and engine ground.	Is the resistance less than 5 Ω ?	Check the starter motor. <Ref. to SC(H4SO)-6, Starter.>	Repair open circuit of ground cable.
4 CHECK HARNESS BETWEEN BATTERY AND IGNITION SWITCH CONNECTOR. 1) Disconnect the connector from ignition switch. 2) Measure the power supply voltage between ignition switch connector and chassis ground. Connector & terminal (B72) No. 1 (+) — Chassis ground (-):	Is the voltage more than 10 V?	Go to step 6.	Repair open circuit in harness between ignition switch and battery, and check fuse SBF No. 4 and SBF No. 1.
5 CHECK IGNITION SWITCH. 1) Disconnect the connector from ignition switch. 2) Measure the resistance between ignition switch terminals while turning ignition switch to the “ST” position. Terminals (B72) No. 1 — No. 3:	Is the resistance less than 5 Ω ?	Go to step 6.	Replace the ignition switch.
6 CHECK TRANSMISSION TYPE.	Is the target AT model?	Go to step 7.	Go to step 9.
7 CHECK INPUT VOLTAGE OF INHIBITOR SWITCH. 1) Turn the ignition switch to OFF. 2) Disconnect the connector from inhibitor switch. 3) Connect the connector to ignition switch. 4) Measure the input voltage between inhibitor switch connector terminal and engine ground while turning ignition switch to ST. Connector & terminal (B12) No. 12 (+) — Engine ground (-):	Is the voltage more than 10 V?	Go to step 8.	Repair open or ground short circuit in harness between inhibitor switch and ignition switch. NOTE: Check security system (if equipped). <Ref. to SL-20, Security System.>
8 CHECK INHIBITOR SWITCH. 1) Place the select lever in the “P” or “N” range. 2) Measure the resistance between inhibitor switch terminals. Connector & terminal (T3) No. 11 — No. 12:	Is the resistance less than 1 Ω ?	Repair open or ground short circuit in harness between inhibitor switch and starter motor.	Replace the inhibitor switch. <Ref. to 4AT-49, Inhibitor Switch.>

DIAGNOSTICS FOR ENGINE STARTING FAILURE

ENGINE (DIAGNOSTICS)

Step	Check	Yes	No
9 CHECK INPUT VOLTAGE OF STARTER INTERLOCK RELAY. 1) Turn ignition switch to OFF. 2) Disconnect the connector from starter interlock relay. 3) Connect the connector to ignition switch. 4) Measure the input voltage between starter interlock relay connector and chassis ground while turning ignition switch to ST. Connector & terminal (B225) No. 28 (+) — Chassis ground (-): (B225) No. 26 (+) — Chassis ground (-):	Is the voltage more than 10 V?	Go to step 10.	Repair open or short circuit to ground in harness between starter interlock relay and ignition switch. NOTE: Check security system (if equipped). <Ref. to SL-20, Security System.>
10 CHECK STARTER INTERLOCK RELAY. 1) Connect the battery to starter interlock relay terminals No. 26 and No. 24. 2) Measure the resistance between starter interlock relay terminals. Terminals (B225) No. 27 — No. 28:	Is the resistance less than 1 Ω ?	Go to step 11.	Replace the starter interlock relay.
11 CHECK GROUND CIRCUIT OF CLUTCH SWITCH. 1) Disconnect the connector from clutch switch. 2) Measure the resistance between clutch switch connector and chassis ground. Connector & terminal (B106) No. 1 — Chassis ground:	Is the resistance less than 1 Ω ?	Go to step 12.	Repair open circuit of ground cable.
12 CHECK CLUTCH SWITCH. Measure the resistance between clutch switch terminals while depressing the clutch pedal. Terminals (B106) No. 1 — No. 2:	Is the resistance less than 1 Ω ?	Go to step 13.	Replace the clutch switch. <Ref. to CL-29, Clutch Switch.>
13 CHECK CLUTCH SWITCH CIRCUIT. 1) Connect the connector to clutch switch. 2) Measure the resistance between starter interlock relay connector and chassis ground while depressing the clutch pedal. Connector & terminal (B225) No. 24 (+) — Chassis ground (-):	Is the resistance less than 1 Ω ?	Repair short circuit to ground in harness between starter interlock relay and starter motor.	Repair open circuit in harness between starter interlock relay and clutch switch.

DIAGNOSTICS FOR ENGINE STARTING FAILURE

ENGINE (DIAGNOSTICS)

C: CONTROL MODULE POWER SUPPLY AND GROUND LINE

CAUTION:

After repair or replacement of faulty parts, conduct Clear Memory Mode <Ref. to EN(H4SO)-49, OPERATION, Clear Memory Mode.> and Inspection Mode <Ref. to EN(H4SO)-40, OPERATION, Inspection Mode.>.

WIRING DIAGRAM:

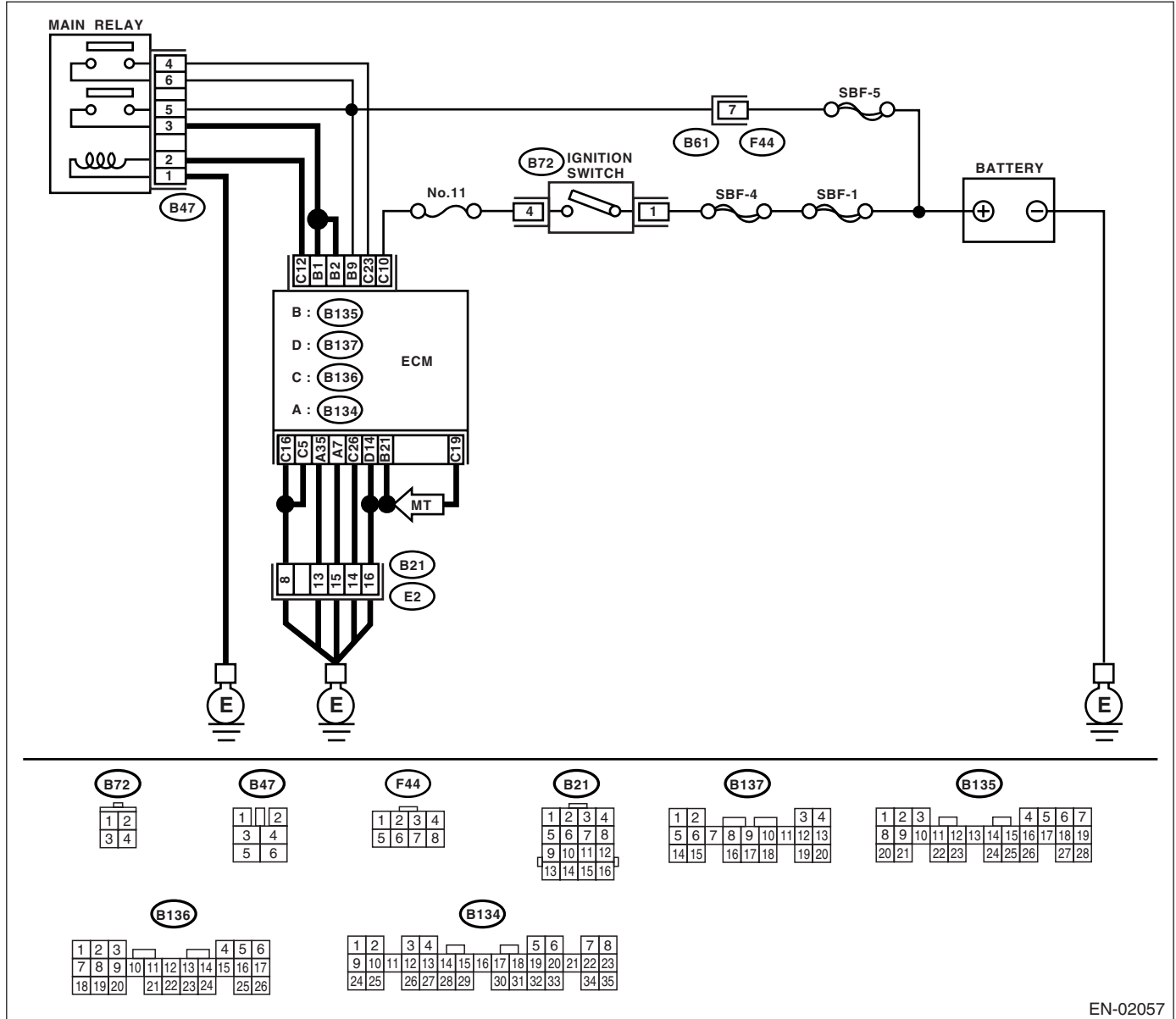

EN-02057

DIAGNOSTICS FOR ENGINE STARTING FAILURE

ENGINE (DIAGNOSTICS)

Step	Check	Yes	No
<p>1 CHECK MAIN RELAY. 1) Turn the ignition switch to OFF. 2) Remove the main relay. 3) Connect the battery to main relay terminals No. 1 and No. 2. 4) Measure the resistance between main relay terminals.</p> <p>Terminals (B47) No. 3 — No. 5: (B47) No. 4 — No. 6:</p>	Is the resistance less than 10 Ω ?	Go to step 2.	Replace the main relay.
<p>2 CHECK GROUND CIRCUIT OF ECM. 1) Disconnect the connector from ECM. 2) Measure the resistance of harness between ECM and chassis ground.</p> <p>Connector & terminal (B134) No. 7 — Chassis ground: (B134) No. 35 — Chassis ground: (B135) No. 21 — Chassis ground: (B136) No. 5 — Chassis ground: (B136) No. 16 — Chassis ground: (B136) No. 19 — Chassis ground: (MT model) (B136) No. 26 — Chassis ground: (B137) No. 14 — Chassis ground:</p>	Is the resistance less than 5 Ω ?	Go to step 3.	Repair open circuit in harness between ECM connector and engine grounding terminal.
<p>3 CHECK INPUT VOLTAGE OF ECM. Measure the voltage between ECM connector and chassis ground.</p> <p>Connector & terminal (B135) No. 9 (+) — Chassis ground (-):</p>	Is the voltage more than 10 V?	Go to step 4.	Repair open or ground short circuit of power supply circuit.
<p>4 CHECK INPUT VOLTAGE OF ECM. 1) Turn the ignition switch to ON. 2) Measure the voltage between ECM connector and chassis ground.</p> <p>Connector & terminal (B136) No. 10 (+) — Chassis ground (-):</p>	Is the voltage more than 10 V?	Go to step 5.	Repair open or ground short circuit of power supply circuit.
<p>5 CHECK HARNESS BETWEEN ECM AND MAIN RELAY CONNECTOR. 1) Turn the ignition switch to OFF. 2) Measure the resistance between ECM and chassis ground.</p> <p>Connector & terminal (B136) No. 12 — Chassis ground:</p>	Is the resistance more than 1 M Ω ?	Go to step 6.	Repair ground short circuit in harness between ECM connector and main relay connector, then replace the ECM.
<p>6 CHECK OUTPUT VOLTAGE FROM ECM. 1) Connect the connector to ECM. 2) Turn the ignition switch to ON. 3) Measure the voltage between ECM connector and chassis ground.</p> <p>Connector & terminal (B136) No. 12 (+) — Chassis ground (-):</p>	Is the voltage more than 10 V?	Go to step 7.	Replace the ECM.
<p>7 CHECK INPUT VOLTAGE OF MAIN RELAY. Check the voltage between main relay connector and chassis ground.</p> <p>Connector & terminal (B47) No. 2 (+) — Chassis ground (-):</p>	Is the voltage more than 10 V?	Go to step 8.	Repair open circuit in harness between ECM connector and main relay connector.

DIAGNOSTICS FOR ENGINE STARTING FAILURE

ENGINE (DIAGNOSTICS)

Step	Check	Yes	No
8 CHECK GROUND CIRCUIT OF MAIN RELAY. 1) Turn the ignition switch to OFF. 2) Measure the resistance between main relay connector and chassis ground. <i>Connector & terminal</i> <i>(B47) No. 1 — Chassis ground:</i>	Is the resistance less than 5 Ω ?	Go to step 9 .	Repair open circuit between main relay and chassis ground.
9 CHECK INPUT VOLTAGE OF MAIN RELAY. Measure the voltage between main relay connector and chassis ground. <i>Connector & terminal</i> <i>(B47) No. 5 (+) — Chassis ground (-):</i> <i>(B47) No. 6 (+) — Chassis ground (-):</i>	Is the voltage more than 10 V?	Go to step 10 .	Repair open or ground short circuit in harness of power supply circuit.
10 CHECK INPUT VOLTAGE OF ECM. 1) Connect the main relay connector. 2) Turn the ignition switch to ON. 3) Measure the voltage between ECM connector and chassis ground. <i>Connector & terminal</i> <i>(B135) No. 1 (+) — Chassis ground (-):</i> <i>(B135) No. 2 (+) — Chassis ground (-):</i>	Is the voltage more than 10 V?	Check ignition control system. <Ref. to EN(H4SO)-69, IGNITION CONTROL SYSTEM, Diagnostics for Engine Starting Failure.>	Repair open or ground short circuit in harness between ECM connector and main relay connector.

DIAGNOSTICS FOR ENGINE STARTING FAILURE

ENGINE (DIAGNOSTICS)

D: IGNITION CONTROL SYSTEM

CAUTION:

After repair or replacement of faulty parts, conduct Clear Memory Mode <Ref. to EN(H4SO)-49, OPERATION, Clear Memory Mode.> and Inspection Mode <Ref. to EN(H4SO)-40, OPERATION, Inspection Mode.>.

WIRING DIAGRAM:

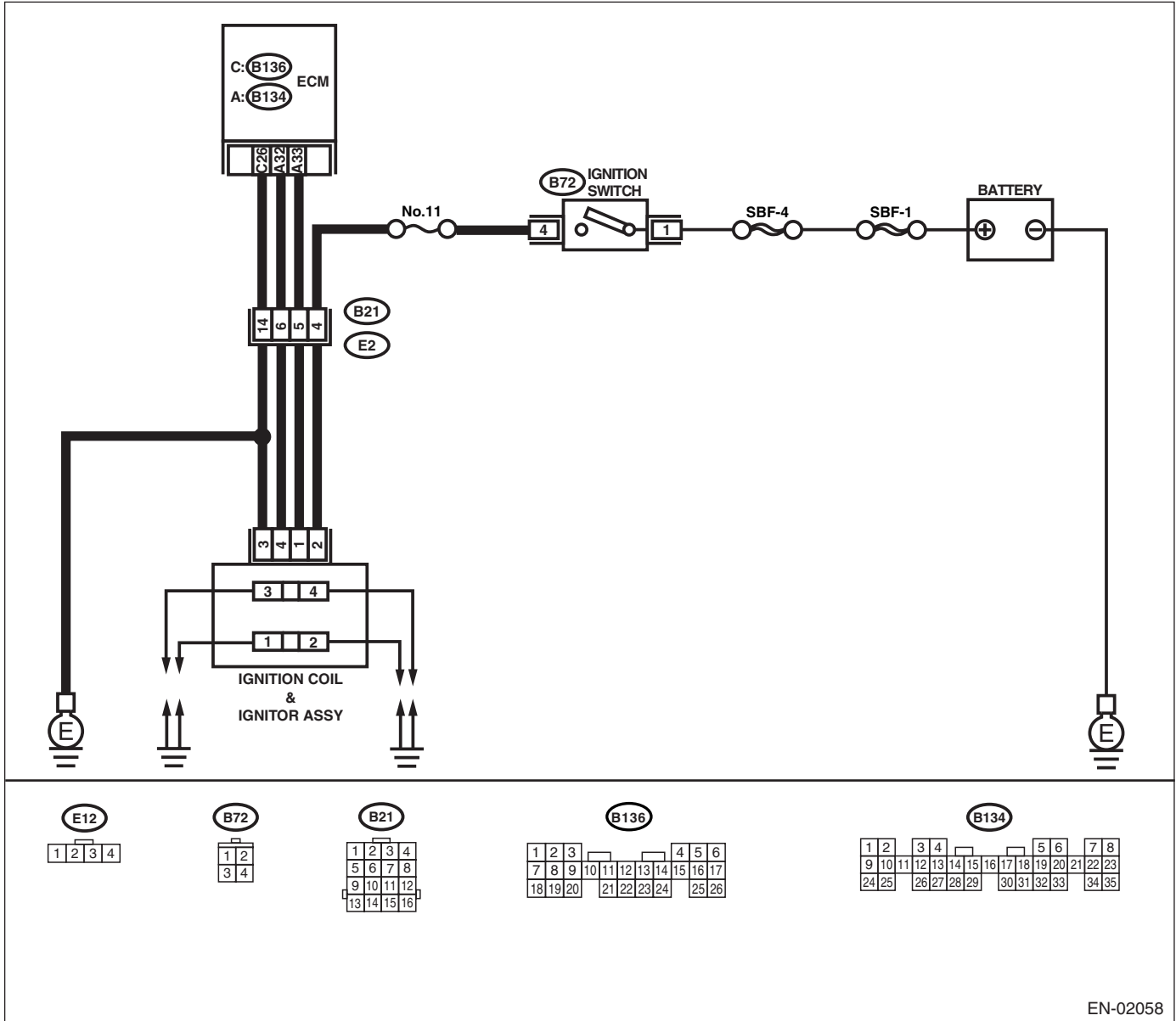

EN-02058

DIAGNOSTICS FOR ENGINE STARTING FAILURE

ENGINE (DIAGNOSTICS)

Step	Check	Yes	No
<p>1</p> <p>CHECK IGNITION SYSTEM FOR SPARKS. 1) Remove the plug cord cap from each spark plug. 2) Install the new spark plug on plug cord cap.</p> <p>CAUTION: Do not remove the spark plug from engine.</p> <p>3) Contact the spark plug's thread portion on engine. 4) While opening the throttle valve fully, crank the engine to check that spark occurs at each cylinder.</p>	Does spark occur at each cylinder?	Check fuel pump system. <Ref. to EN(H4SO)-72, FUEL PUMP CIRCUIT, Diagnostics for Engine Starting Failure.>	Go to step 2.
<p>2</p> <p>CHECK POWER SUPPLY CIRCUIT FOR IGNITION COIL & IGNITOR ASSY. 1) Turn the ignition switch to OFF. 2) Disconnect the connector from ignition coil & ignitor ASSY. 3) Turn the ignition switch to ON. 4) Measure the power supply voltage between ignition coil & ignitor ASSY connector and engine ground.</p> <p>Connector & terminal (E12) No. 2 (+) — Engine ground (-):</p>	Is the voltage more than 10 V?	Go to step 3.	Repair harness and connector. NOTE: In this case, repair the following: • Open circuit in harness between ignition coil & ignitor ASSY, and ignition switch connector • Poor contact in coupling connectors
<p>3</p> <p>CHECK HARNESS OF IGNITION COIL & IGNITOR ASSY GROUND CIRCUIT. 1) Turn the ignition switch to OFF. 2) Measure the resistance between ignition coil & ignitor ASSY connector and engine ground.</p> <p>Connector & terminal (E12) No. 3 — Engine ground:</p>	Is the resistance less than 5 Ω ?	Go to step 4.	Repair harness and connector. NOTE: In this case, repair the following: • Open circuit in harness between ignition coil & ignitor ASSY connector and engine grounding terminal
<p>4</p> <p>CHECK IGNITION COIL & IGNITOR ASSY. 1) Remove the spark plug cords. 2) Measure the resistance between spark plug cord contact portions to check secondary coil.</p> <p>Terminals (E12) No. 1 — No. 2: (E12) No. 3 — No. 4:</p>	Is the resistance 10 — 15 k Ω ?	Go to step 5.	Replace the ignition coil & ignitor ASSY. <Ref. to IG(H4SO)-8, Ignition Coil and Ignitor Assembly.>
<p>5</p> <p>CHECK INPUT SIGNAL FOR IGNITION COIL & IGNITOR ASSY. 1) Connect the connector to ignition coil & ignitor ASSY. 2) Check if voltage varies synchronously with engine speed when cranking, while monitoring voltage between ignition coil & ignitor ASSY connector and engine ground.</p> <p>Connector & terminal (E12) No. 1 (+) — Engine ground (-): (E12) No. 4 (+) — Engine ground (-):</p>	Does the voltage vary more than 10 V?	Go to step 6.	Replace the ignition coil & ignitor ASSY. <Ref. to IG(H4SO)-8, Ignition Coil and Ignitor Assembly.>

DIAGNOSTICS FOR ENGINE STARTING FAILURE

ENGINE (DIAGNOSTICS)

Step	Check	Yes	No
6 CHECK HARNESS BETWEEN ECM AND IGNITION COIL & IGNITOR ASSY CONNECTOR. 1) Turn the ignition switch to OFF. 2) Disconnect the connector from ECM. 3) Disconnect the connector from ignition coil & ignitor ASSY. 4) Measure the resistance of harness between ECM and ignition coil & ignitor ASSY connector. <i>Connector & terminal</i> <i>(B134) No. 33 — (E12) No. 1:</i> <i>(B134) No. 32 — (E12) No. 4:</i>	Is the resistance less than 1 Ω ?	Go to step 7.	Repair harness and connector. NOTE: In this case, repair the following: <ul style="list-style-type: none"> • Open circuit in harness between ECM and ignition coil & ignitor ASSY connector • Poor contact in coupling connector
7 CHECK HARNESS BETWEEN ECM AND IGNITION COIL & IGNITOR ASSY CONNECTOR. Measure the resistance of harness between ECM and engine ground. <i>Connector & terminal:</i> <i>(B134) No. 33 — Engine ground:</i> <i>(B134) No. 32 — Engine ground:</i>	Is the resistance more than 1 $M\Omega$?	Go to step 8.	Repair ground short circuit in harness between ECM and ignition coil & ignitor ASSY connector.
8 CHECK POOR CONTACT. Check poor contact in ECM connector.	Is there poor contact in ECM connector?	Repair poor contact in ECM connector.	Check fuel pump circuit. <Ref. to EN(H4SO)-72, FUEL PUMP CIRCUIT, Diagnostics for Engine Starting Failure.>

DIAGNOSTICS FOR ENGINE STARTING FAILURE

ENGINE (DIAGNOSTICS)

E: FUEL PUMP CIRCUIT

CAUTION:

After repair or replacement of faulty parts, conduct Clear Memory Mode <Ref. to EN(H4SO)-49, OPERATION, Clear Memory Mode.> and Inspection Mode <Ref. to EN(H4SO)-40, OPERATION, Inspection Mode.>.

WIRING DIAGRAM:

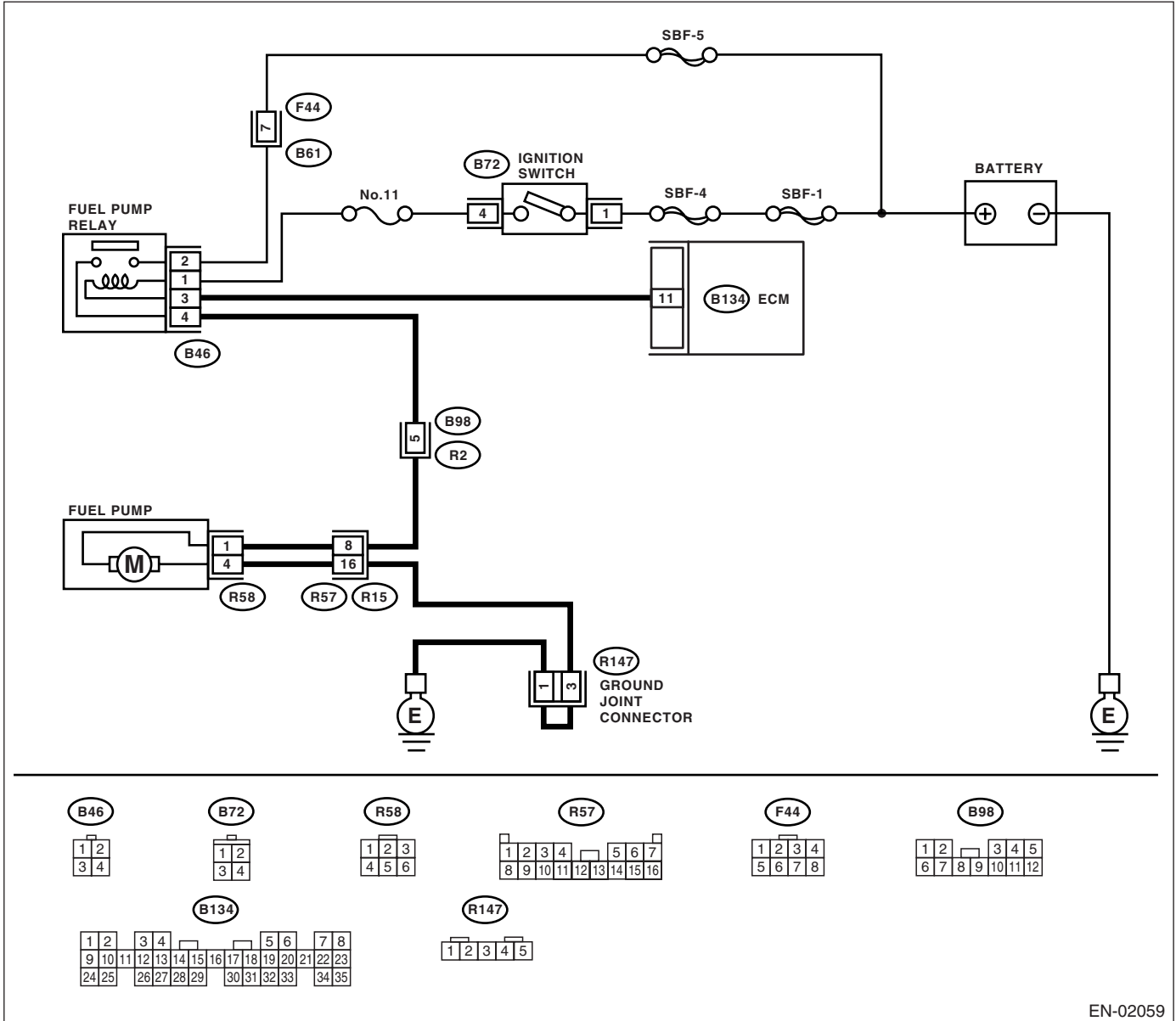

EN-02059

DIAGNOSTICS FOR ENGINE STARTING FAILURE

ENGINE (DIAGNOSTICS)

Step	Check	Yes	No
<p>1 CHECK OPERATING SOUND OF FUEL PUMP. Make sure that fuel pump is in operation for two seconds when turning the ignition switch to ON.</p> <p>NOTE: Fuel pump operation can also be executed using Subaru Select Monitor. For the procedure, refer to "Compulsory Valve Operation Check Mode". <Ref. to EN(H4SO)-50, Compulsory Valve Operation Check Mode.></p>	Does the fuel pump produce operating sound?	Check fuel injector circuit. <Ref. to EN(H4SO)-75, FUEL INJECTOR CIRCUIT, Diagnostics for Engine Starting Failure.>	Go to step 2.
<p>2 CHECK GROUND CIRCUIT OF FUEL PUMP. 1) Turn the ignition switch to OFF. 2) Remove the fuel pump access hole lid. 3) Disconnect the connector from fuel pump. 4) Measure the resistance of harness connector between fuel pump and chassis ground.</p> <p>Connector & terminal (R58) No. 4 — Chassis ground:</p>	Is the resistance less than 5 Ω ?	Go to step 3.	<p>Repair harness and connector.</p> <p>NOTE: In this case, repair the following:</p> <ul style="list-style-type: none"> • Open circuit in harness between fuel pump connector and chassis grounding terminal • Poor contact in coupling connector
<p>3 CHECK POWER SUPPLY TO FUEL PUMP. 1) Turn the ignition switch to ON. 2) Measure the voltage of power supply circuit between fuel pump connector and chassis ground.</p> <p>Connector & terminal (R58) No. 1 (+) — Chassis ground (-):</p>	Is the voltage more than 10 V?	Replace the fuel pump. <Ref. to FU(H4SO)-57, Fuel Pump.>	Go to step 4.
<p>4 CHECK HARNESS BETWEEN FUEL PUMP AND FUEL PUMP RELAY CONNECTOR. 1) Turn the ignition switch to OFF. 2) Measure the resistance of harness connector between fuel pump and fuel pump relay.</p> <p>Connector & terminal (R58) No. 1 — (B46) No. 4:</p>	Is the resistance less than 1 Ω ?	Go to step 5.	<p>Repair harness and connector.</p> <p>NOTE: In this case, repair the following:</p> <ul style="list-style-type: none"> • Open circuit in harness between fuel pump connector and chassis grounding terminal • Poor contact in coupling connectors
<p>5 CHECK HARNESS BETWEEN FUEL PUMP AND FUEL PUMP RELAY CONNECTOR. Measure the resistance of harness between fuel pump and fuel pump relay connector.</p> <p>Connector & terminal (R58) No. 1 — Chassis ground:</p>	Is the resistance more than 1 $M\Omega$?	Go to step 6.	Repair short circuit in harness between fuel pump and fuel pump relay connector.

DIAGNOSTICS FOR ENGINE STARTING FAILURE

ENGINE (DIAGNOSTICS)

Step	Check	Yes	No
6 CHECK FUEL PUMP RELAY. 1) Disconnect the connectors from fuel pump relay and main relay. 2) Remove the fuel pump relay and main relay with bracket. 3) Connect the battery to fuel pump relay connector terminals No. 1 and No. 3. 4) Measure the resistance between connector terminals of fuel pump relay. <i>Terminals</i> <i>(R58) No. 2 — No. 4:</i>	Is the resistance less than 10 Ω ?	Go to step 7.	Replace the fuel pump relay. <Ref. to FU(H4SO)-48, Fuel Pump Relay.>
7 CHECK HARNESS BETWEEN ECM AND FUEL PUMP RELAY CONNECTOR. 1) Disconnect the connectors from ECM. 2) Measure the resistance of harness between ECM and fuel pump relay connector. <i>Connector & terminal</i> <i>(B134) No. 11 — (B46) No. 3:</i>	Is the resistance less than 1 Ω ?	Go to step 8.	Repair open circuit in harness between ECM and fuel pump relay connector.
8 CHECK POOR CONTACT. Check poor contact in ECM connector.	Is there poor contact in ECM connector?	Repair poor contact in ECM connector.	Check fuel injector circuit. <Ref. to EN(H4SO)-75, FUEL INJECTOR CIRCUIT, Diagnostics for Engine Starting Failure.>

DIAGNOSTICS FOR ENGINE STARTING FAILURE

ENGINE (DIAGNOSTICS)

F: FUEL INJECTOR CIRCUIT

CAUTION:

- Check or repair only faulty parts.
- After repair or replacement of faulty parts, conduct Clear Memory Mode <Ref. to EN(H4SO)-49, OPERATION, Clear Memory Mode.> and Inspection Mode <Ref. to EN(H4SO)-40, OPERATION, Inspection Mode.>.

WIRING DIAGRAM:

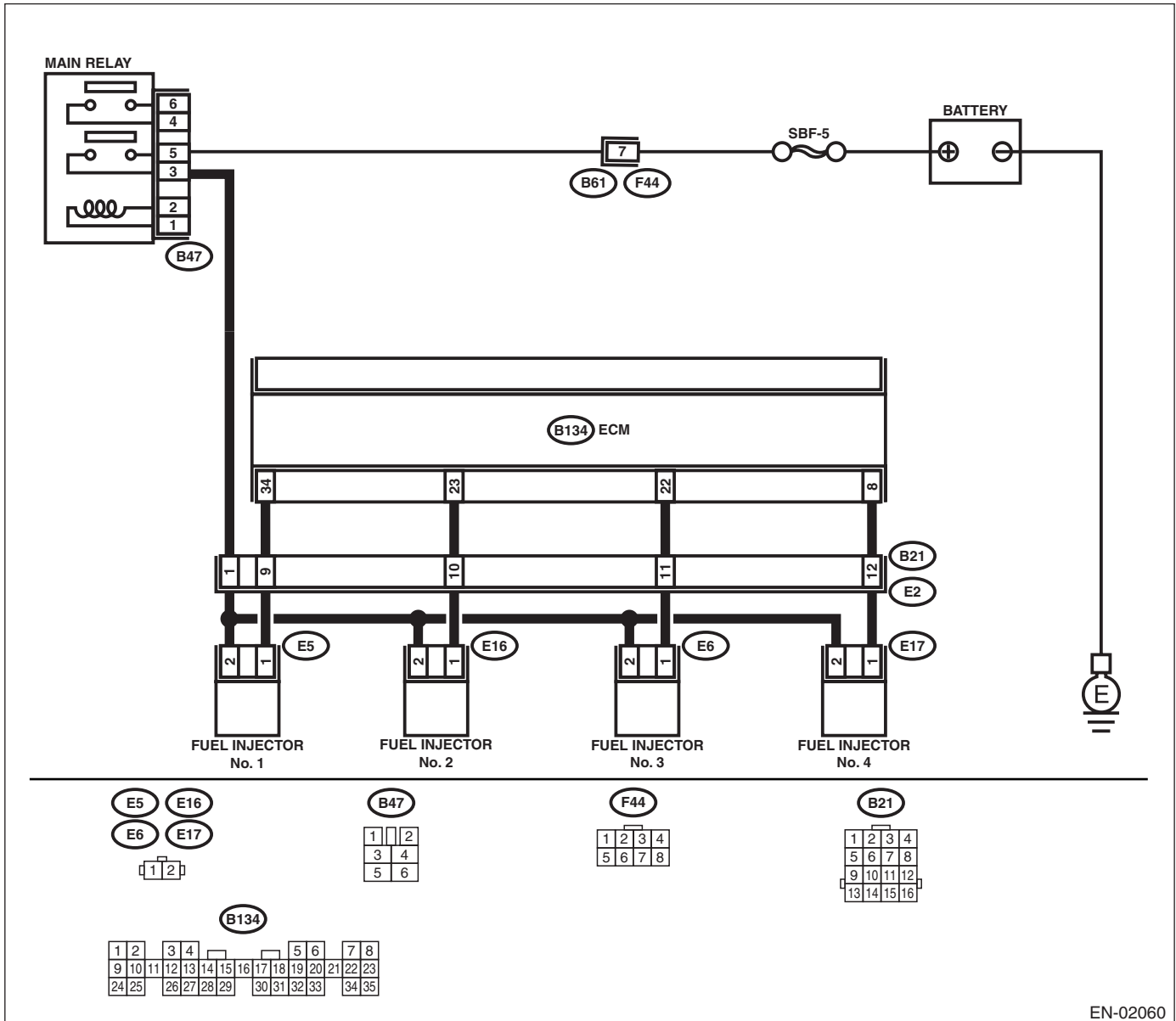

EN-02060

DIAGNOSTICS FOR ENGINE STARTING FAILURE

ENGINE (DIAGNOSTICS)

Step	Check	Yes	No
<p>1 CHECK OPERATION OF EACH FUEL INJECTOR. While cranking the engine, check that each fuel injector emits “operating” sound. Use a sound scope or attach a screwdriver to the injector for this check.</p>	Dose the fuel injector operate?	Check the fuel pressure. <Ref. to ME(H4SO)-30, INSPECTION, Fuel Pressure.>	Go to step 2.
<p>2 CHECK POWER SUPPLY TO EACH FUEL INJECTOR. 1) Turn the ignition switch to OFF. 2) Disconnect the connector from fuel injector. 3) Turn the ignition switch to ON. 4) Measure the power supply voltage between the fuel injector terminal and engine ground. Connector & terminal #1 (E5) No. 2 (+) — Engine ground (-): #2 (E16) No. 2 (+) — Engine ground (-): #3 (E6) No. 2 (+) — Engine ground (-): #4 (E17) No. 2 (+) — Engine ground (-):</p>	Is the voltage more than 10 V?	Go to step 3.	Repair harness and connector. NOTE: In this case, repair the following: <ul style="list-style-type: none"> • Open circuit in harness between main relay and fuel injector connector • Poor contact in main relay connector • Poor contact in coupling connector (B22) • Poor contact in fuel injector connector
<p>3 CHECK HARNESS BETWEEN ECM AND FUEL INJECTOR CONNECTOR. 1) Disconnect the connector from ECM. 2) Measure the resistance of harness between ECM and fuel injector connector. Connector & terminal #1 (B134) No. 34 — (E5) No. 1: #2 (B134) No. 23 — (E16) No. 1: #3 (B134) No. 22 — (E6) No. 1: #4 (B134) No. 8 — (E17) No. 1:</p>	Is the resistance less than 1 Ω ?	Go to step 4.	Repair harness and connector. NOTE: In this case, repair the following: <ul style="list-style-type: none"> • Open circuit in harness between ECM and fuel injector connector • Poor contact in coupling connector
<p>4 CHECK HARNESS BETWEEN ECM AND FUEL INJECTOR CONNECTOR. Measure the resistance of harness between ECM and fuel injector connector. Connector & terminal #1 (B134) No. 34 — Chassis ground: #2 (B134) No. 23 — Chassis ground: #3 (B134) No. 22 — Chassis ground: #4 (B134) No. 8 — Chassis ground:</p>	Is the resistance more than 1 M Ω ?	Go to step 5.	Repair ground short circuit in harness between ECM and fuel injector connector.
<p>5 CHECK EACH FUEL INJECTOR. 1) Turn the ignition switch to OFF. 2) Measure the resistance between each fuel injector terminals. Terminals No. 1 — No. 2:</p>	Is the resistance 5 — 20 Ω ?	Go to step 6.	Replace the faulty fuel injector.
<p>6 CHECK POOR CONTACT. Check poor contact in ECM connector.</p>	Is there poor contact in ECM connector?	Repair poor contact in ECM connector.	Inspection using “General Diagnostic Table”. <Ref. to EN(H4SO)-323, INSPECTION, General Diagnostic Table.>