

## 2. Diagnostic Trouble Code (DTC) Detecting Criteria

### A: DTC P0030 — HO2S HEATER CONTROL CIRCUIT (BANK 1 SENSOR 1) —

#### 1. OUTLINE OF DIAGNOSIS

Detect the malfunction of front oxygen (A/F) sensor heater.

Diagnosis is performed using A/F microcomputer, and communication is established between A/F microcomputer and main microcomputer. Judge NG when the data of heater malfunction NG is transmitted.

Judge NG when the front oxygen (A/F) sensor element impedance is out of the standard value.

#### 2. COMPONENT DESCRIPTION

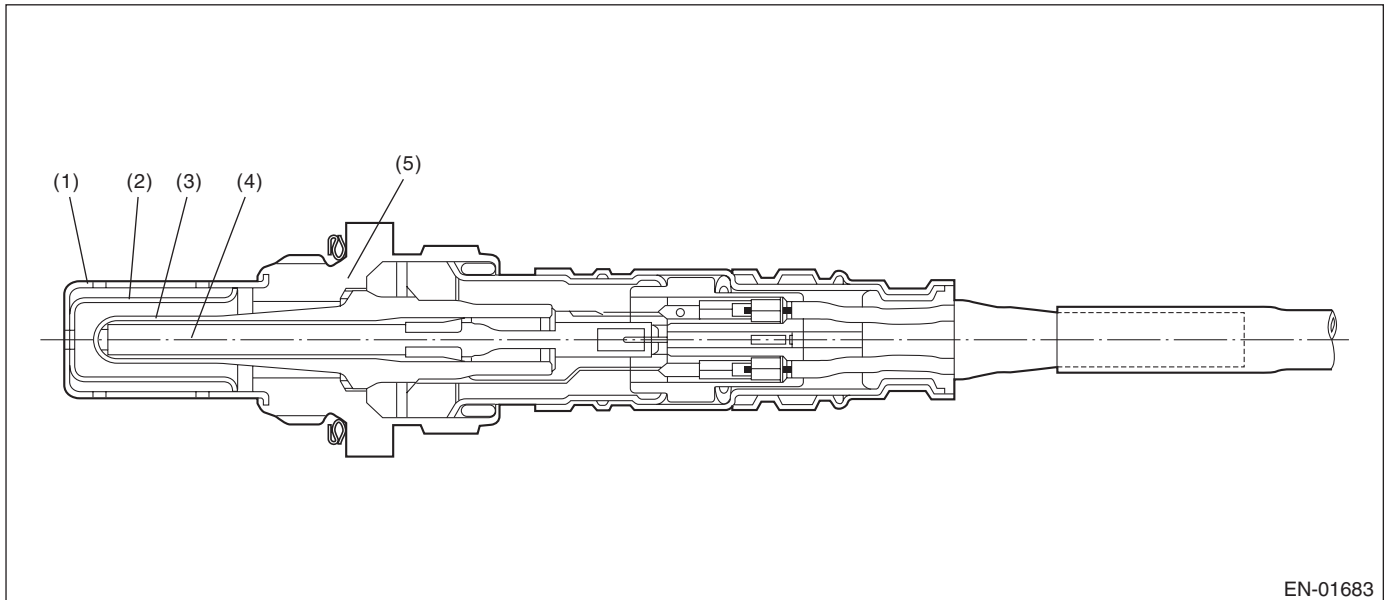

EN-01683

- (1) Element cover (outer)
- (2) Element cover (inner)
- (3) Sensor element
- (4) Ceramic heater
- (5) Sensor housing

#### 3. ENABLE CONDITIONS

Secondary Parameters	Enable Conditions
Battery voltage	> 10.9 V
After heater control starting	More than 30 seconds
After fuel shut-off	More than 20 seconds

#### 4. GENERAL DRIVING CYCLE

Perform the diagnosis continuously in 30 seconds after the heater continuity starting, and complete the diagnosis if making a NG judgment.

# DIAGNOSTIC TROUBLE CODE (DTC) DETECTING CRITERIA

## GENERAL DESCRIPTION

---

### 5. DIAGNOSTIC METHOD

#### • Abnormality Judgment

Judge NG when one of the malfunction criteria below is completed.

#### Judgment Value

Malfunction Criteria	Threshold Value
Impedance of front oxygen (A/F) sensor	< 10 $\Omega$ or > 40 $\Omega$

**Time Needed for Diagnosis:** 120 seconds

**Malfunction Indicator Light Illumination:** Illuminates when malfunction occurs in 2 continuous driving cycles.

#### • Normality Judgment

Judge OK when all of the malfunction criteria below is completed.

#### Judgment Value

Malfunction Criteria	Threshold Value
Impedance of front oxygen (A/F) sensor	10 — 40 $\Omega$

### 6. DTC CLEAR CONDITION

- When the OK idling cycle was completed 40 times in a row
- When "Clear Memory" was performed

### 7. MALFUNCTION INDICATOR LIGHT CLEAR CONDITION

- When the OK driving cycle was completed 3 times in a row
- When "Clear Memory" was performed

### 8. FAIL SAFE

None

### 9. ECM OPERATION AT DTC SETTING

Memorize the freeze frame data. (For test mode \$02)

# DIAGNOSTIC TROUBLE CODE (DTC) DETECTING CRITERIA

GENERAL DESCRIPTION

## B: DTC P0031 — HO2S HEATER CONTROL CIRCUIT LOW (BANK 1 SENSOR 1)

### 1. OUTLINE OF DIAGNOSIS

Detect the open or short circuit of front oxygen (A/F) sensor heater.

Diagnosis is performed using A/F microcomputer, and communication is established between A/F microcomputer and main microcomputer. Judge NG when the data of open circuit and shortage NG is transmitted.

### 2. COMPONENT DESCRIPTION

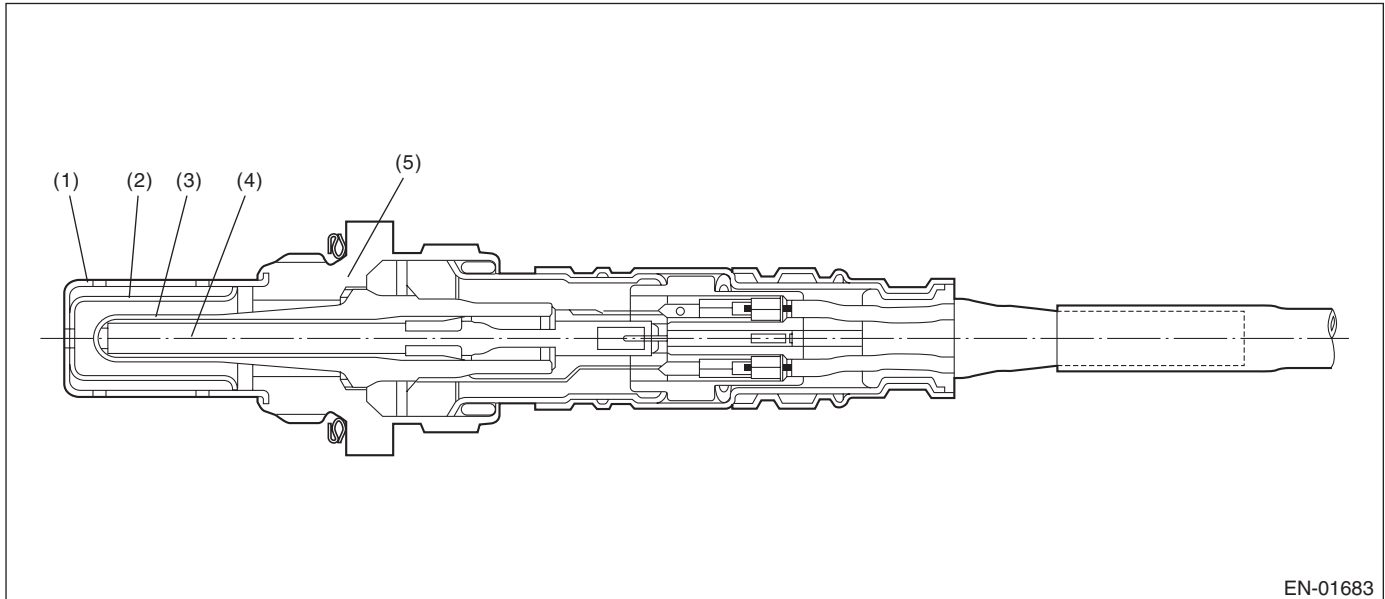

EN-01683

- (1) Element cover (outer)
- (2) Element cover (inner)
- (3) Sensor element
- (4) Ceramic heater
- (5) Sensor housing

### 3. ENABLE CONDITION

Secondary Parameters	Enable Conditions
Battery voltage	10.9 V or more
Heater control	Operation

### 4. GENERAL DRIVING CYCLE

Terminate the diagnosis if the open or short circuit becomes NG once by performing diagnosis continuously.

### 5. DIAGNOSTIC METHOD

Judge NG when the continuous time of completing all the malfunction criteria below becomes more than 4.5 seconds.

#### Judgment Value

Malfunction Criteria	Threshold Value
Heater circuit	ON
Heater both edge voltage	< 5 V
Heater current	< 1.5 A

**Time Needed for Diagnosis:** 4.5 seconds

**Malfunction Indicator Light Illumination:** Illuminates as soon as malfunction occurs.

# DIAGNOSTIC TROUBLE CODE (DTC) DETECTING CRITERIA

## GENERAL DESCRIPTION

---

### 6. DTC CLEAR CONDITION

- When the OK idling cycle was completed 40 times in a row
- When "Clear Memory" was performed

### 7. MALFUNCTION INDICATOR LIGHT CLEAR CONDITION

- When the OK driving cycle was completed 3 times in a row
- When "Clear Memory" was performed

### 8. FAIL SAFE

None

### 9. ECM OPERATION AT DTC SETTING

Memorize the freeze frame data. (For test mode \$02)

## C: DTC P0032 — HO<sub>2</sub>S HEATER CONTROL CIRCUIT HIGH (BANK 1 SENSOR 1) —

### 1. OUTLINE OF DIAGNOSIS

Detect the open or short circuit of front oxygen (A/F) sensor heater.

Diagnosis is performed using A/F microcomputer, and communication is established between A/F microcomputer and main microcomputer. Judge NG when the data of open circuit and shortage NG is transmitted.

### 2. COMPONENT DESCRIPTION

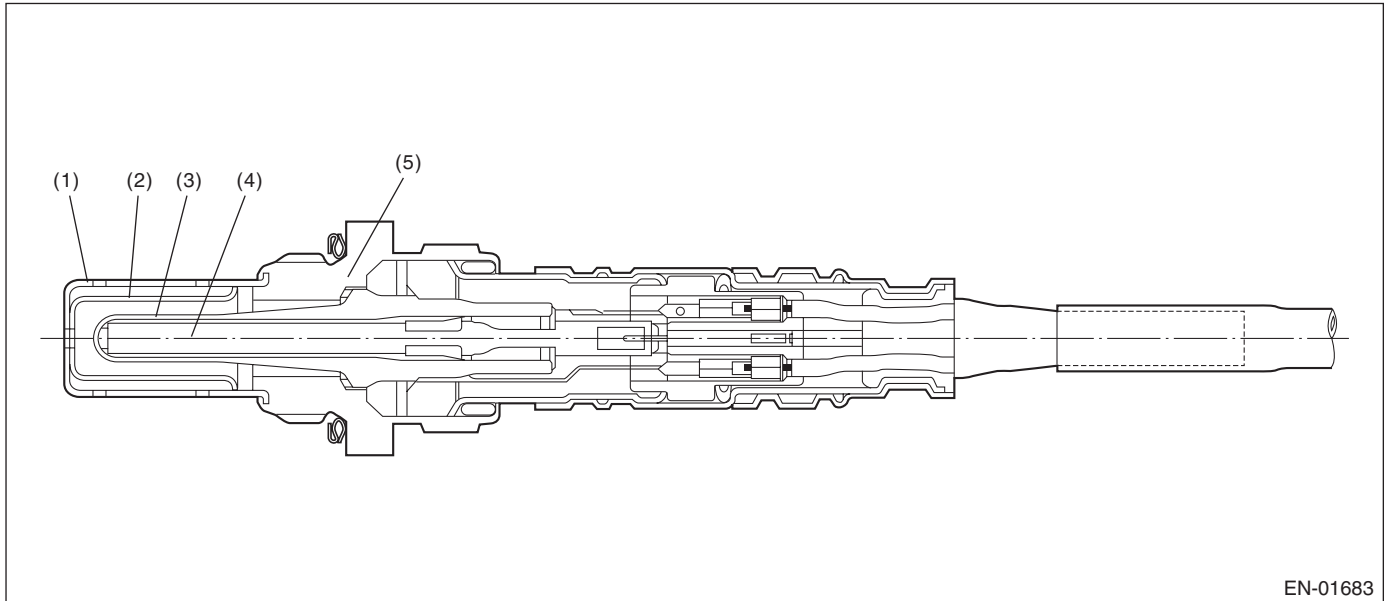

EN-01683

- (1) Element cover (outer)
- (2) Element cover (inner)
- (3) Sensor element
- (4) Ceramic heater
- (5) Sensor housing

### 3. ENABLE CONDITION

Secondary Parameters	Enable Conditions
Battery voltage	10.9 V or more
Heater control	Operation

### 4. GENERAL DRIVING CYCLE

Terminate the diagnosis if the open or short circuit becomes NG once by performing diagnosis continuously.

# DIAGNOSTIC TROUBLE CODE (DTC) DETECTING CRITERIA

## GENERAL DESCRIPTION

---

### 5. DIAGNOSTIC METHOD

Judge NG when any of the malfunction criteria below is completed.

#### Judgment Value

Malfunction Criteria	Threshold Value
Heater circuit	OFF
Heater both edge voltage	$\geq 5$ V
Heater current	$\geq 1.5$ A
Heater current	$\geq 23$ A

**Time Needed for Diagnosis:** 4.5 seconds

**Malfunction Indicator Light Illumination:** Illuminates as soon as malfunction occurs.

### 6. DTC CLEAR CONDITION

- When the OK idling cycle was completed 40 times in a row
- When "Clear Memory" was performed

### 7. MALFUNCTION INDICATOR LIGHT CLEAR CONDITION

- When the OK driving cycle was completed 3 times in a row
- When "Clear Memory" was performed

### 8. FAIL SAFE

None

### 9. ECM OPERATION AT DTC SETTING

Memorize the freeze frame data. (For test mode \$02)

## D: DTC P0037 — HO2S HEATER CONTROL CIRCUIT LOW (BANK 1 SENSOR 2)

### 1. OUTLINE OF DIAGNOSIS

Detect the open or short circuit of rear oxygen sensor heater.  
Judge NG when out of the standard value.

### 2. COMPONENT DESCRIPTION

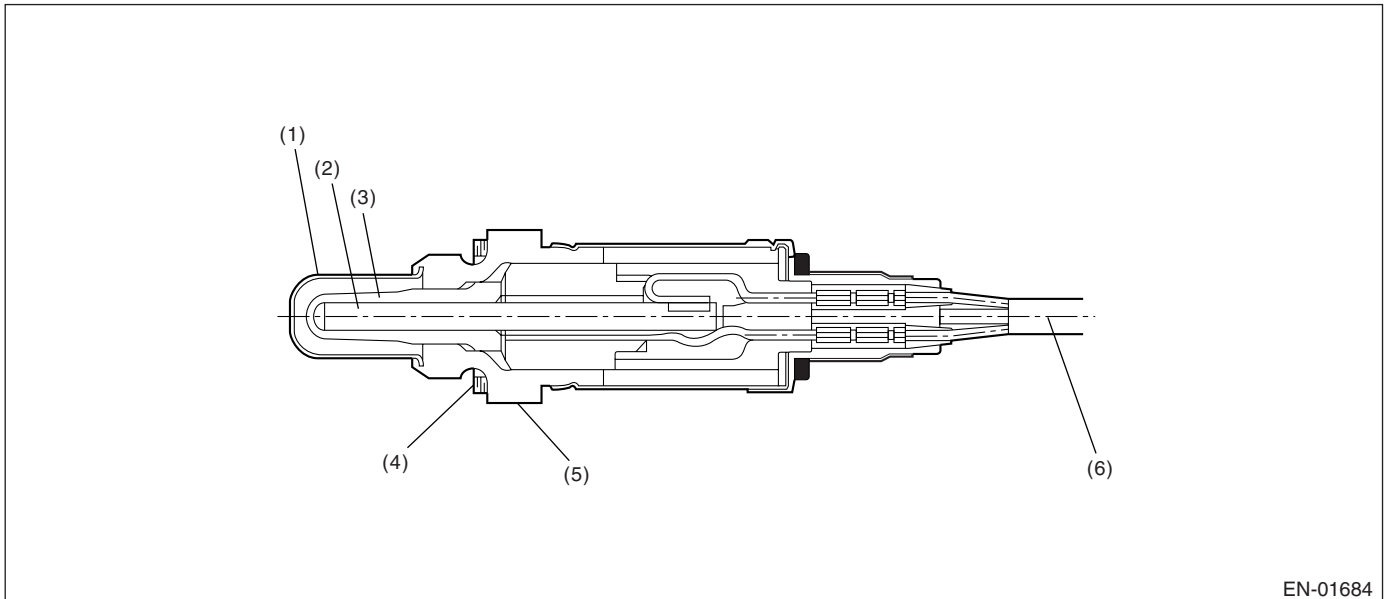

- |                     |                    |
|---------------------|--------------------|
| (1) Protection tube | (4) Gasket         |
| (2) Ceramic heater  | (5) Sensor housing |
| (3) Zirconium tube  | (6) Harness        |

### 3. ENABLE CONDITION

Secondary Parameters	Enable Conditions
Ignition switch	ON
Engine speed	≥ 500 rpm
After engine starting	10 seconds or more
Battery voltage	≥ 8 V

### 4. GENERAL DRIVING CYCLE

In 10 seconds after starting the engine, perform the diagnosis just once.

### 5. DIAGNOSTIC METHOD

Judge NG when the continuous time until completing the malfunction criteria below becomes 10 seconds or more. Judge OK when the continuous time until completing none of the malfunction criteria below becomes 10 seconds or more.

#### Judgment Value

Malfunction Criteria	Threshold Value
Calculated electric power	< 6 watts

**Time needed for diagnosis:** 10 seconds

**Malfunction Indicator Light Illumination:** Illuminates when malfunction occurs in 2 continuous driving cycles.

# DIAGNOSTIC TROUBLE CODE (DTC) DETECTING CRITERIA

## GENERAL DESCRIPTION

---

### 6. DTC CLEAR CONDITION

- When the OK idling cycle was completed 40 times in a row
- When "Clear Memory" was performed

### 7. MALFUNCTION INDICATOR LIGHT CLEAR CONDITION

- When the OK driving cycle was completed 3 times in a row
- When "Clear Memory" was performed

### 8. FAIL SAFE

None

### 9. ECM OPERATION AT DTC SETTING

- Memorize the freeze frame data. (For test mode \$02)
- Memorize the diagnostic value and trouble standard value. (For test mode \$06)



# DIAGNOSTIC TROUBLE CODE (DTC) DETECTING CRITERIA

GENERAL DESCRIPTION

## E: DTC P0038 — HO<sub>2</sub>S HEATER CONTROL CIRCUIT HIGH (BANK 1 SENSOR 2) —

### 1. OUTLINE OF DIAGNOSIS

Detect the open or short circuit of rear oxygen sensor heater.  
Judge NG when out of the standard value.

### 2. COMPONENT DESCRIPTION

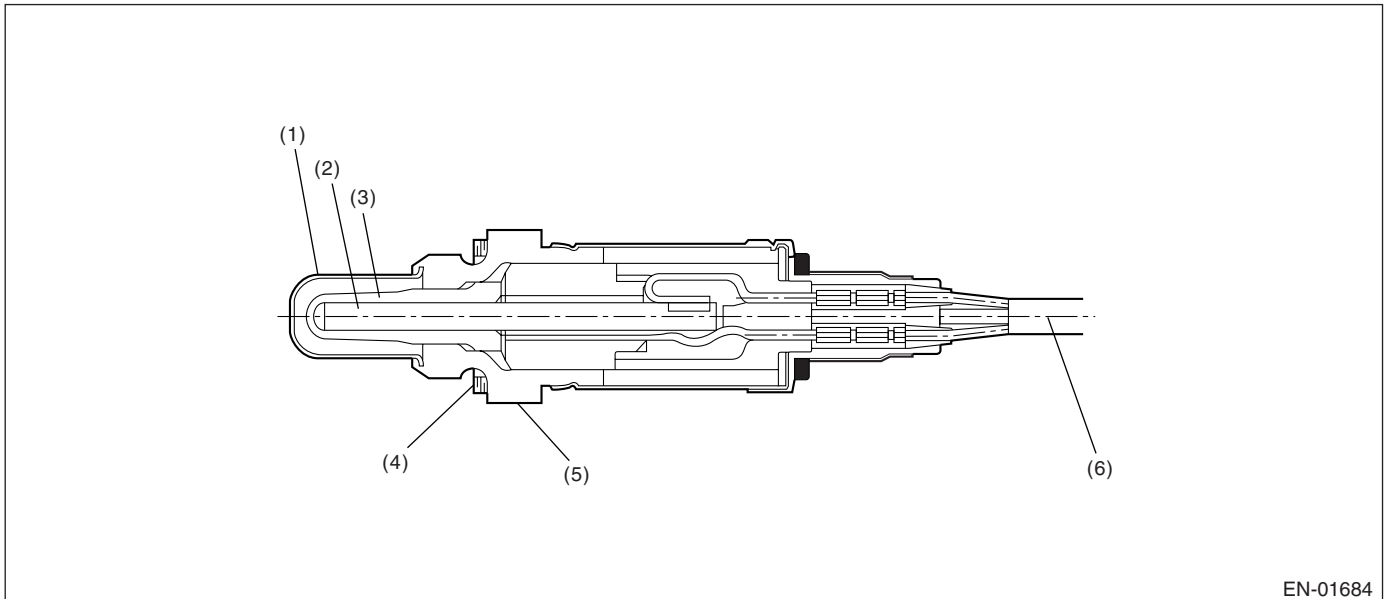

- (1) Protection tube
- (2) Ceramic heater
- (3) Zirconium tube

- (4) Gasket
- (5) Sensor housing
- (6) Harness

### 3. ENABLE CONDITION

Secondary Parameters	Enable Conditions
Ignition switch	ON
Engine speed	≥ 500 rpm
After engine starting	10 seconds or more
Battery voltage	≥ 8 V

### 4. GENERAL DRIVING CYCLE

In 10 seconds after starting the engine, perform the diagnosis just once.

### 5. DIAGNOSTIC METHOD

Judge NG when the continuous time until completing the malfunction criteria below becomes 10 seconds or more. Judge OK when the continuous time until completing none of the malfunction criteria below becomes 10 seconds or more.

#### Judgment Value

Malfunction Criteria	Threshold Value
Calculated electric power	≥ 50 watts

**Time needed for diagnosis:** 10 seconds

**Malfunction Indicator Light Illumination:** Illuminates when malfunction occurs in 2 continuous driving cycles.

# DIAGNOSTIC TROUBLE CODE (DTC) DETECTING CRITERIA

## GENERAL DESCRIPTION

---

### 6. DTC CLEAR CONDITION

- When the OK idling cycle was completed 40 times in a row
- When "Clear Memory" was performed

### 7. MALFUNCTION INDICATOR LIGHT CLEAR CONDITION

- When the OK driving cycle was completed 3 times in a row
- When "Clear Memory" was performed

### 8. FAIL SAFE

None

### 9. ECM OPERATION AT DTC SETTING

- Memorize the freeze frame data. (For test mode \$02)
- Memorize the diagnostic value and trouble standard value. (For test mode \$06)

## F: DTC P0065 — AIR ASSISTED INJECTOR CONTROL RANGE/PERFORMANCE —

### 1. OUTLINE OF DIAGNOSIS

Detect the malfunction of AAI solenoid valve.

Intake manifold pressure (negative pressure) is constant because the throttle valve is fully closed during fuel cut at deceleration. At this time, opening AAI solenoid valve makes the intake manifold pressure larger. For AAI solenoid valve function diagnosis, judge OK or NG by the amount of change of intake manifold pressure when opening and closing the AAI solenoid valve.

**Max. value with the valve open – Min. value with the valve closed < Threshold value → NG**

**Max. value with the valve open – Min. value with the valve closed ≥ Threshold value → OK**

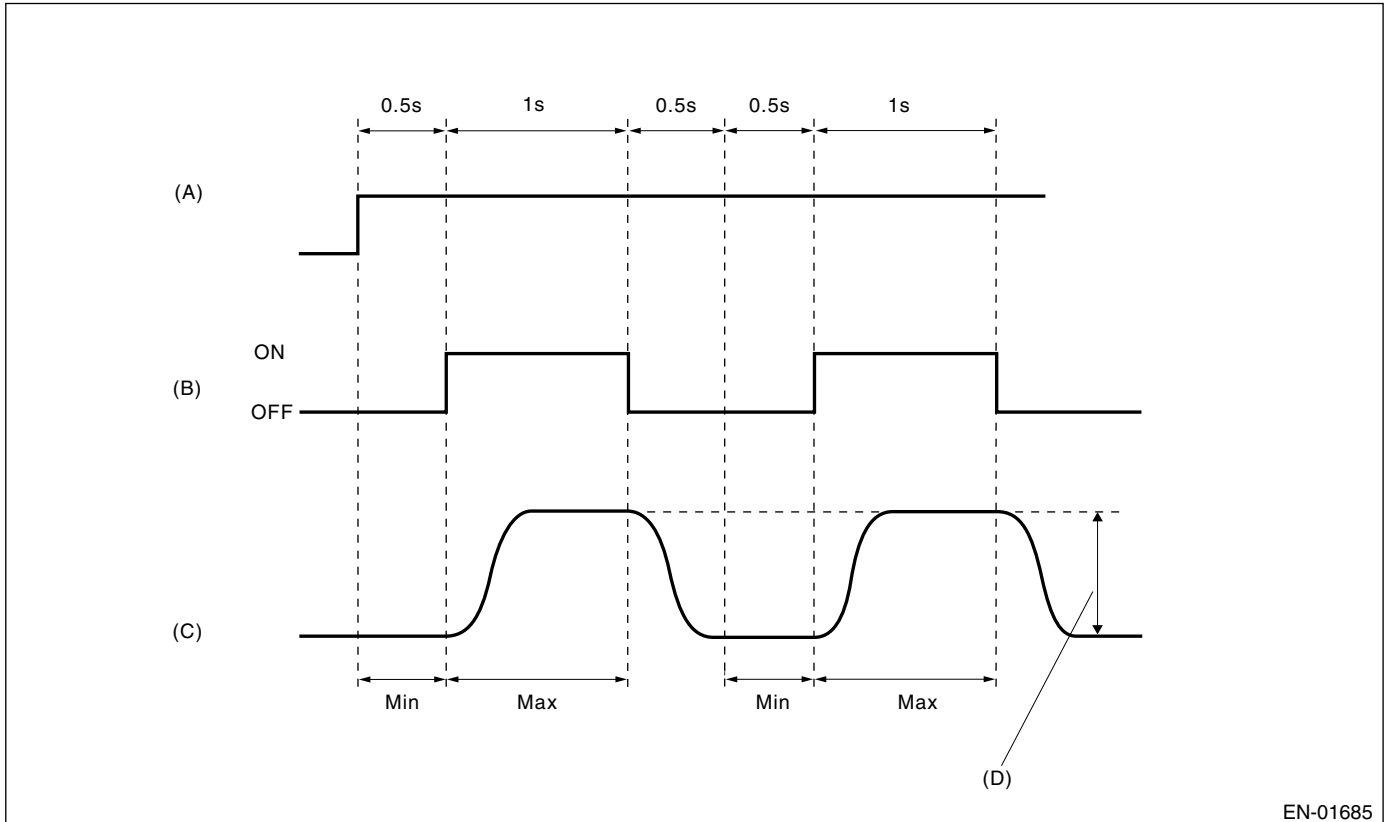

EN-01685

- (A) Conditions executed for diagnosis
- (B) AAI solenoid valve
- (C) Intake manifold pressure (At normal condition)
- (D) Diagnostic value

# DIAGNOSTIC TROUBLE CODE (DTC) DETECTING CRITERIA

## GENERAL DESCRIPTION

### 2. COMPONENT DESCRIPTION

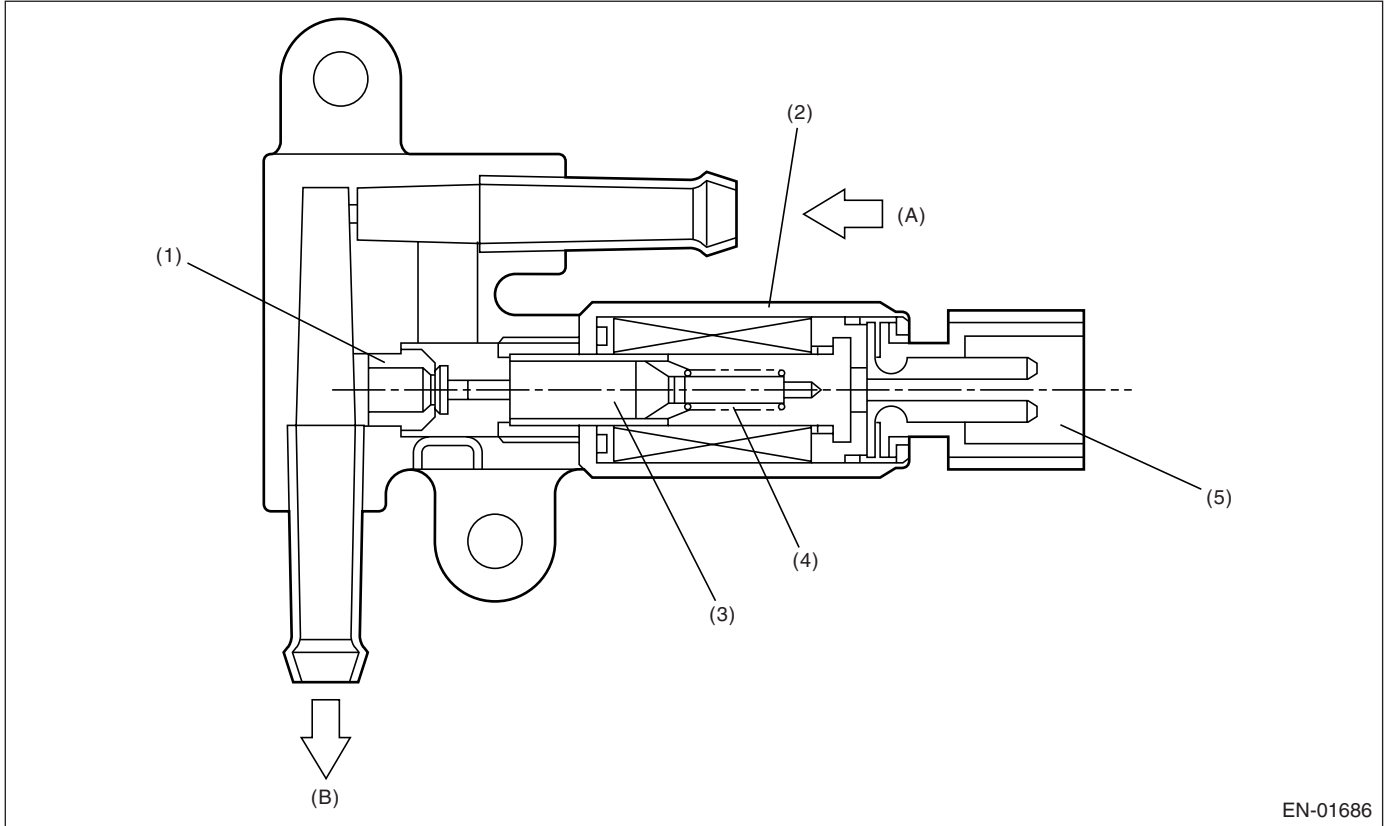

- (1) Valve seat
- (2) Solenoid
- (3) Plunger and valve
- (4) Spring
- (5) Connector

- (A) From idle air control solenoid valve
- (B) To injector

### 3. ENABLE CONDITION

Secondary Parameters	Enable Conditions
Engine coolant temperature	$\geq 75^{\circ}\text{C}$ (167°F)
Engine speed	1,300 $\leftrightarrow$ 2,300 rpm
Vehicle speed	$\geq 60$ km/h (37 MPH)
Atmospheric pressure	$\geq 86$ kPa (642 mmHg, 25 inHg)
Atmospheric-MAP	$\geq 53$ kPa (400 mmHg, 16 inHg)
Fuel cut event by coasting	In operation
AAI solenoid valve position	OFF (closed)

### 4. GENERAL DRIVING CYCLE

Conduct a serial diagnosis during fuel cut at deceleration from more than 60 km/h (37 MPH). Be careful for vehicle speed and engine speed. (Diagnosis may not finish if the vehicle speed and engine speed conditions become out of specification.)

### 5. DIAGNOSTIC METHOD

Judge NG when the malfunction criteria below are completed 2 times in a row. Judge OK and clear the NG if not completed once

# DIAGNOSTIC TROUBLE CODE (DTC) DETECTING CRITERIA

GENERAL DESCRIPTION

## Judgment Value

Malfunction Criteria	Threshold Value
Paai1 — Paai2	
Paai1; max. MAP value during AAI solenoid valve ON signal	700 Pa (5 mmHg, 0.2 inHg) (101 kPa (760 mmHg, 30 inHg) atmospheric pressure condition)
Paai2; min. MAP value during 0.5 seconds just before changing the valve from OFF to ON	53 Pa (0.4 mmHg, 0.016 inHg) (86 kPa (642 mmHg, 25 inHg) atmospheric pressure condition)

**Time needed for diagnosis:** 9 seconds

**Malfunction Indicator Light Illumination:** Illuminates when malfunction occurs in 2 continuous driving cycles.

## 6. DTC CLEAR CONDITION

- When the OK idling cycle is completed 40 times in a row
- When “Clear Memory” was performed

## 7. MALFUNCTION INDICATOR LIGHT CLEAR CONDITION

- When the OK driving cycle is completed 3 times in a row
- When “Clear Memory” was performed

## 8. FAIL SAFE

None

## 9. ECM OPERATION AT DTC SETTING

Memorize the freeze frame data. (For test mode \$02)

# DIAGNOSTIC TROUBLE CODE (DTC) DETECTING CRITERIA

## GENERAL DESCRIPTION

### G: DTC P0066 — AIR ASSISTED INJECTOR CONTROL CIRCUIT OR CIRCUIT LOW —

#### 1. OUTLINE OF DIAGNOSIS

Detect the open or short circuit of AAI solenoid valve. Judge NG when the ECM output level is different from actual terminal level.

#### 2. COMPONENT DESCRIPTION

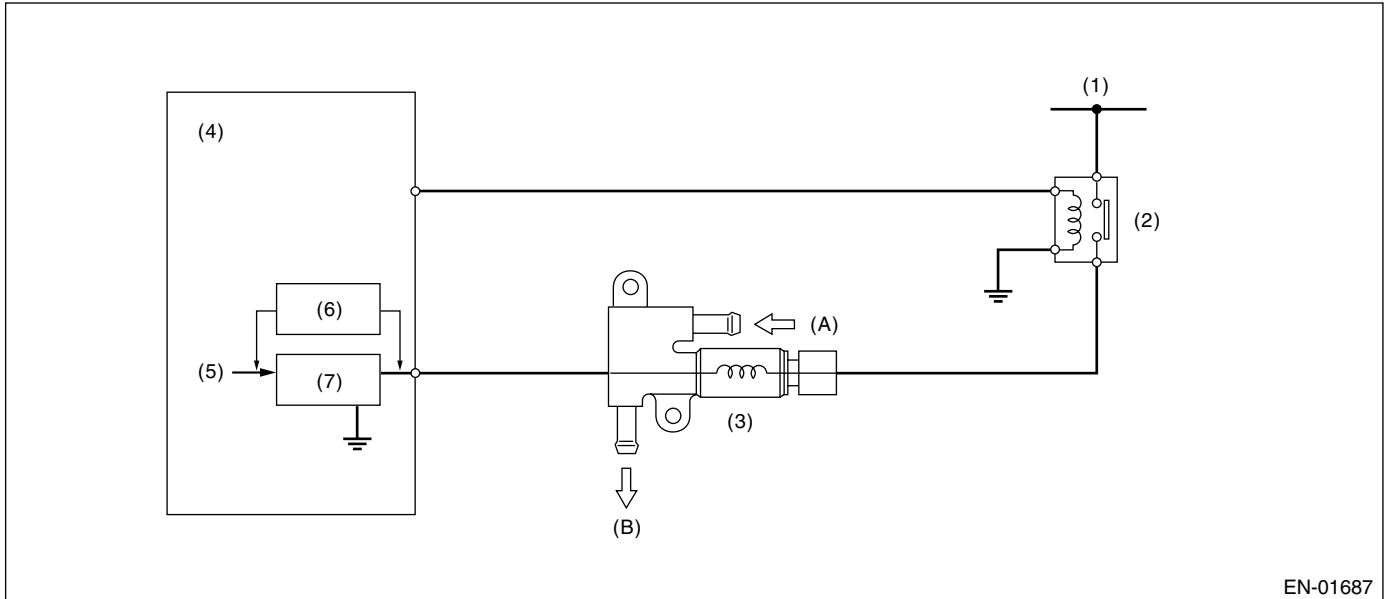

(1) Battery voltage

(2) Main relay

(3) AAI solenoid valve

(4) Engine control module (ECM)

(5) CPU

(6) Detecting circuit

(7) Switching circuit

(A) From idle air control solenoid valve

(B) To injector

#### 3. ENABLE CONDITION

Secondary Parameters	Enable Conditions
Engine speed	$\geq 500$ rpm
Battery voltage	$\geq 10.9$ V
After engine starting	2 seconds or more
Ignition switch	ON

#### 4. GENERAL DRIVING CYCLE

Perform the diagnosis continuously in 2 seconds after starting the engine.

# DIAGNOSTIC TROUBLE CODE (DTC) DETECTING CRITERIA

GENERAL DESCRIPTION

## 5. DIAGNOSTIC METHOD

### • Abnormality Judgment

Judge NG when the cumulative time until completing the malfunction criteria below becomes more than the time needed for diagnosis (2.5 seconds).

### Judgment Value

Malfunction Criteria	Threshold Value
Terminal voltage level while ECM sent OFF signal	Low level

**Time Needed for Diagnosis:** 2.5 seconds

**Malfunction Indicator Light Illumination:** Illuminates when malfunction occurs in 2 continuous driving cycles.

### • Normality Judgment

Judge OK and clear the NG when the malfunction criteria below are completed.

### Judgment Value

Malfunction Criteria	Threshold Value
Terminal voltage level while ECM sent OFF signal	High level

## 6. DTC CLEAR CONDITION

- When the OK idling cycle is completed 40 times in a row
- When "Clear Memory" was performed

## 7. MALFUNCTION INDICATOR LIGHT CLEAR CONDITION

- When the OK driving cycle is completed 3 times in a row
- When "Clear Memory" was performed

## 8. FAIL SAFE

None

## 9. ECM OPERATION AT DTC SETTING

Memorize the freeze frame data. (For test mode \$02)

# DIAGNOSTIC TROUBLE CODE (DTC) DETECTING CRITERIA

## GENERAL DESCRIPTION

### H: DTC P0067 — AIR ASSISTED INJECTOR CONTROL CIRCUIT HIGH —

#### 1. OUTLINE OF DIAGNOSIS

Detect the open or short circuit of AAI solenoid valve. Judge NG when the ECM output level is different from actual terminal level.

#### 2. COMPONENT DESCRIPTION

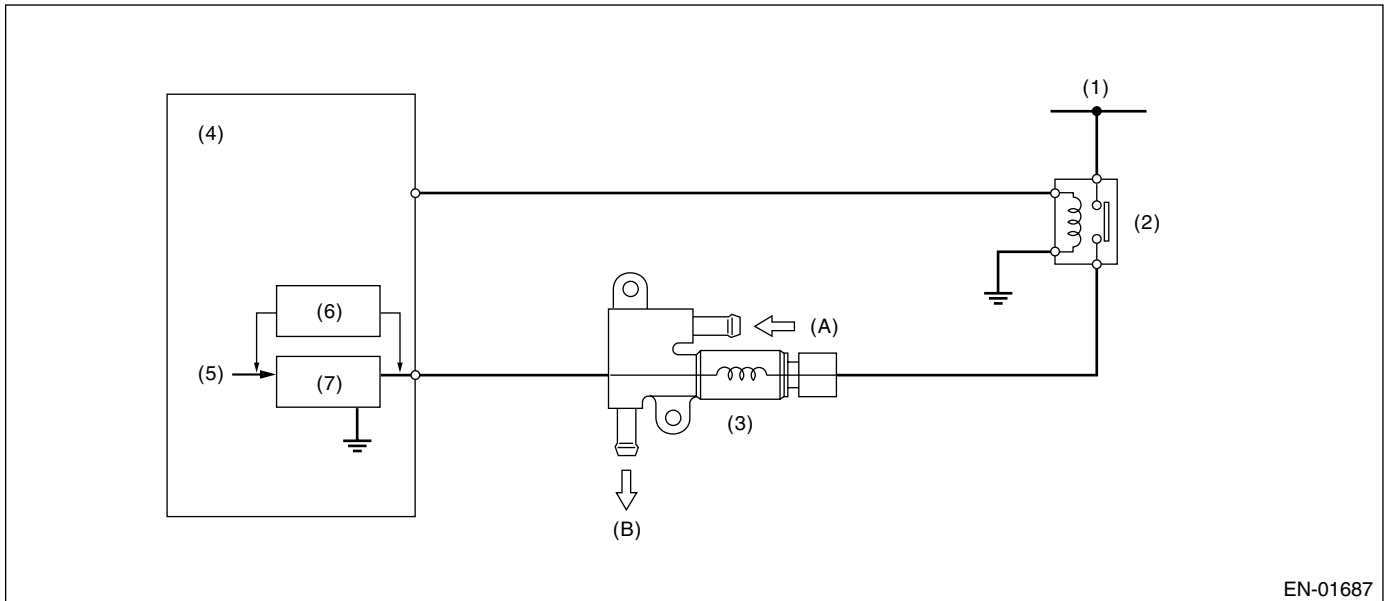

(1) Battery voltage

(2) Main relay

(3) AAI solenoid valve

(4) Engine control module (ECM)

(5) CPU

(6) Detecting circuit

(7) Switching circuit

(A) From idle air control solenoid valve

(B) To injector

#### 3. ENABLE CONDITION

Secondary Parameters	Enable Conditions
Engine speed	$\geq 500$ rpm
Battery voltage	$\geq 10.9$ V
After engine starting	2 seconds or more
Ignition switch	ON

#### 4. GENERAL DRIVING CYCLE

Perform the diagnosis continuously in 2 seconds after starting the engine.



# DIAGNOSTIC TROUBLE CODE (DTC) DETECTING CRITERIA

GENERAL DESCRIPTION

## 5. DIAGNOSTIC METHOD

### • Abnormality Judgment

Judge NG when the cumulative time until completing the malfunction criteria below becomes more than the time needed for diagnosis.

### Judgment Value

Malfunction Criteria	Threshold Value
Terminal voltage level while ECM sent OFF signal	High level

**Time Needed for Diagnosis:** 2.5 seconds

**Malfunction Indicator Light Illumination:** Illuminates when malfunction occurs in 2 continuous driving cycles.

### • Normality Judgment

Judge OK and clear the NG when the malfunction criteria below are completed.

### Judgment Value

Malfunction Criteria	Threshold Value
Terminal voltage level while ECM sent OFF signal	Low level

## 6. DTC CLEAR CONDITION

- When the OK idling cycle is completed 40 times in a row
- When "Clear Memory" was performed

## 7. MALFUNCTION INDICATOR LIGHT CLEAR CONDITION

- When the OK driving cycle is completed 3 times in a row
- When "Clear Memory" was performed

## 8. FAIL SAFE

None

## 9. ECM OPERATION AT DTC SETTING

Memorize the freeze frame data. (For test mode \$02)

# DIAGNOSTIC TROUBLE CODE (DTC) DETECTING CRITERIA

## GENERAL DESCRIPTION

### I: DTC P0068 — MANIFOLD PRESSURE SENSOR RANGE/PERFORMANCE —

#### 1. OUTLINE OF DIAGNOSIS

Detect the malfunction of intake manifold pressure sensor output property.

Judge NG when the intake manifold pressure is small (voltage is low) regardless of the driving situation that the intake manifold pressure may be thought larger than engine speed and throttle opening. (Low side)

On the other hand, judge NG when the intake manifold pressure is large (voltage is high) regardless of the driving situation that the intake manifold pressure may be thought smaller than engine speed and throttle opening. (High side)

#### 2. COMPONENT DESCRIPTION

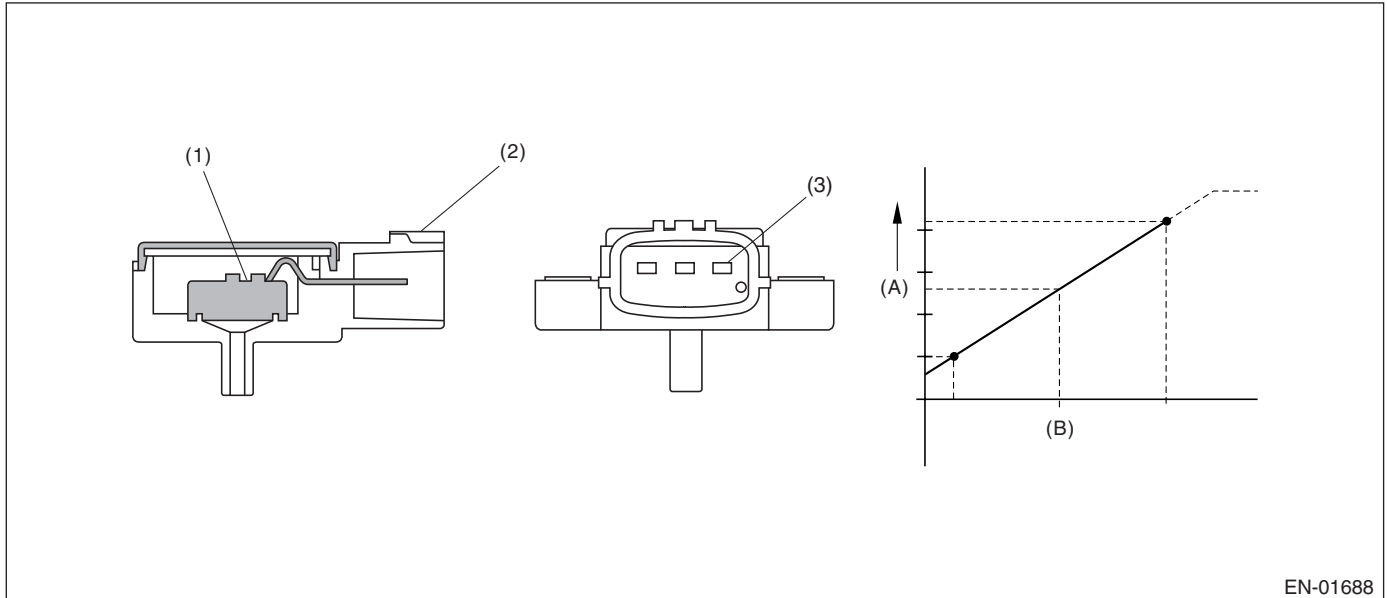

- (1) Pressure detecting part
- (2) Connector
- (3) Terminal

- (A) Output voltage
- (B) Input voltage

EN-01688

#### 3. ENABLE CONDITION

Secondary Parameters	Enable Conditions
Engine coolant temperature	$\geq 75^{\circ}\text{C}$ ( $167^{\circ}\text{F}$ )

#### 4. GENERAL DRIVING CYCLE

Perform the diagnosis continuously after idling.

# DIAGNOSTIC TROUBLE CODE (DTC) DETECTING CRITERIA

GENERAL DESCRIPTION

## 5. DIAGNOSTIC METHOD

### • Abnormality Judgment

Judge NG when the continuous time of completing all the malfunction criteria of Low side or High side below becomes more than the time (3 seconds) needed for diagnosis.

### Judgment Value

Malfunction Criteria	Threshold Value
(Low side)	
Engine speed	> 2,500 rpm
Throttle position	> 15°
Output voltage	≤ 0.985 V
(High side)	
Engine speed	600 ←→ 900 rpm
Throttle position	≤ 2°
Output voltage	> 2.81 V

**Time Needed for Diagnosis:** 3 seconds

**Malfunction Indicator Light Illumination:** Illuminates when malfunction occurs in 2 continuous driving cycles.

### • Normality Judgment

Judge OK and clear the NG when all the malfunction criteria of Low side or High side are completed.

### Judgment Value

Malfunction Criteria	Threshold Value
(Low side)	
Engine speed	> 2,500 rpm
Throttle position	> 15°
Output voltage	> 0.985 V
(High side)	
Engine speed	600 ←→ 900 rpm
Throttle position	≤ 2°
Output voltage	≤ 2.81 V

## 6. DTC CLEAR CONDITION

- When the OK idling cycle is completed 40 times in a row
- When "Clear Memory" was performed

## 7. MALFUNCTION INDICATOR LIGHT CLEAR CONDITION

- When the OK driving cycle is completed 3 times in a row
- When "Clear Memory" was performed

## 8. FAIL SAFE

None

## 9. ECM OPERATION AT DTC SETTING

Memorize the freeze frame data. (For test mode \$02)

# DIAGNOSTIC TROUBLE CODE (DTC) DETECTING CRITERIA

## GENERAL DESCRIPTION

### J: DTC P0107 — MANIFOLD ABSOLUTE PRESSURE/BAROMETRIC PRESSURE CIRCUIT LOW INPUT —

#### 1. OUTLINE OF DIAGNOSIS

Detect the open or short circuit of intake manifold pressure sensor.  
Judge NG when out of the standard value.

#### 2. COMPONENT DESCRIPTION

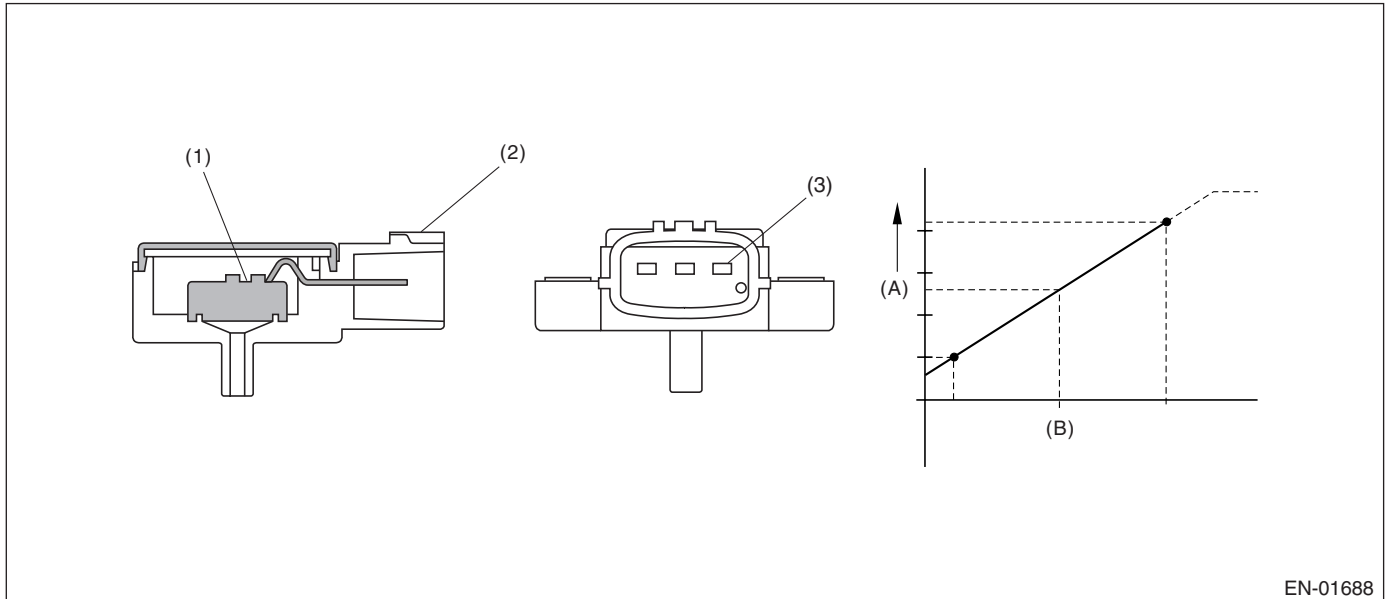

- (1) Pressure detecting part
- (2) Connector
- (3) Terminal

- (A) Output voltage
- (B) Input voltage

#### 3. ENABLE CONDITION

Secondary Parameters	Enable Conditions
None	

#### 4. GENERAL DRIVING CYCLE

Always perform the diagnosis continuously after starting the engine.

#### 5. DIAGNOSTIC METHOD

Judge NG when the continuous time until completing the malfunction criteria below becomes more than the time (2.5 seconds) needed for diagnosis. Judge fail safe NG when the continuous time until completing the malfunction criteria below becomes more than time (0.1 seconds) needed for diagnosis. Judge OK and clear the NG when the malfunction criteria below are not completed.

##### Judgment Value

Malfunction Criteria	Threshold Value
Output voltage	$\leq 0.14 \text{ V}$

**Time Needed for Diagnosis:** 2.5 seconds

**Malfunction Indicator Light Illumination:** Illuminates as soon as malfunction occurs.

#### 6. DTC CLEAR CONDITION

- When the OK idling cycle is completed 40 times in a row
- When "Clear Memory" was performed

# DIAGNOSTIC TROUBLE CODE (DTC) DETECTING CRITERIA

GENERAL DESCRIPTION

---

## 7. MALFUNCTION INDICATOR LIGHT CLEAR CONDITION

- When the OK driving cycle is completed 3 times in a row
- When "Clear Memory" was performed

## 8. FAIL SAFE

Calculate the manifold absolute pressure using the map figured by engine speed and throttle opening grid.

## 9. ECM OPERATION AT DTC SETTING

Memorize the freeze frame data. (For test mode \$02)

# DIAGNOSTIC TROUBLE CODE (DTC) DETECTING CRITERIA

## GENERAL DESCRIPTION

### K: DTC P0108 — MANIFOLD ABSOLUTE PRESSURE/BAROMETRIC PRESSURE CIRCUIT HIGH INPUT —

#### 1. OUTLINE OF DIAGNOSIS

Detect the open or short circuit of intake manifold pressure sensor.  
Judge NG when out of the standard value.

#### 2. COMPONENT DESCRIPTION

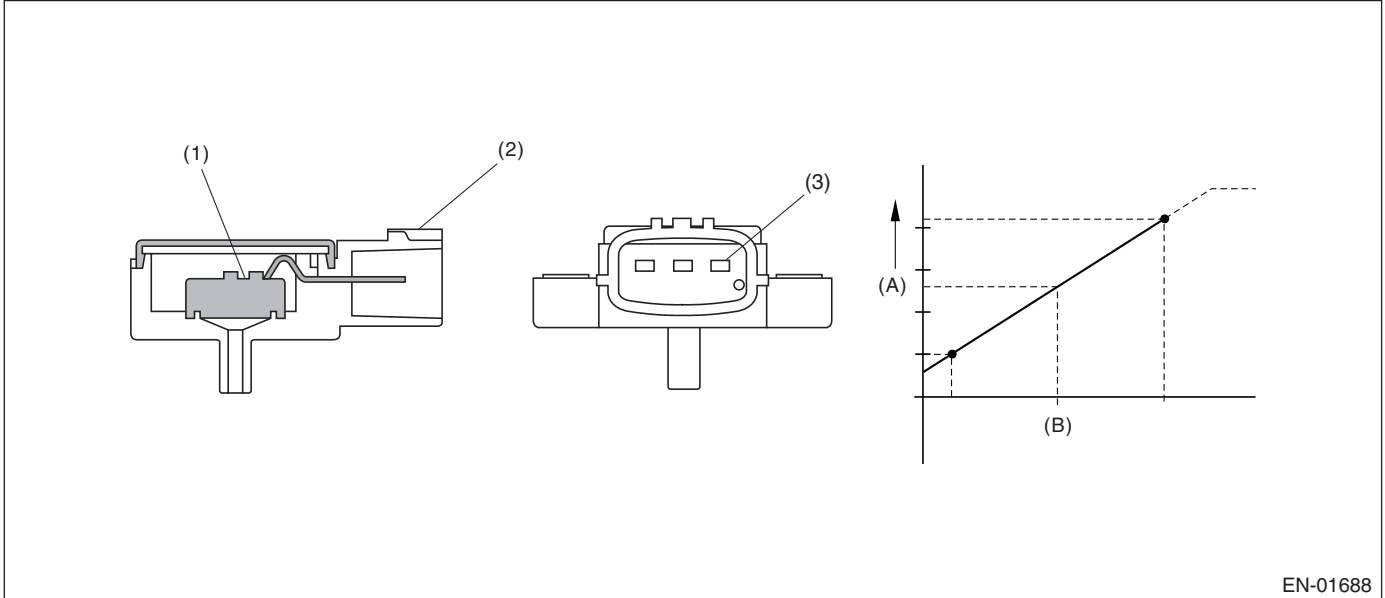

- (1) Pressure detecting part
- (2) Connector
- (3) Terminal

- (A) Output voltage
- (B) Input voltage

EN-01688

#### 3. ENABLE CONDITION

Secondary Parameters	Enable Conditions
None	

#### 4. GENERAL DRIVING CYCLE

Always perform the diagnosis continuously after starting the engine.

#### 5. DIAGNOSTIC METHOD

Judge NG when the continuous time until completing the malfunction criteria below becomes more than the time (2.5 seconds) needed for diagnosis. Judge fail safe NG when the continuous time until completing the malfunction criteria below becomes more than time (0.1 seconds) needed for diagnosis. Judge OK and clear the NG when the malfunction criteria below are not completed.

##### Judgment value

Malfunction Criteria	Threshold Value
Output voltage	$\geq 4.88 \text{ V}$

**Time Needed for Diagnosis:** 2.5 seconds

**Malfunction Indicator Light Illumination:** Illuminates as soon as malfunction occurs.

#### 6. DTC CLEAR CONDITION

- When the OK idling cycle is completed 40 times in a row
- When "Clear Memory" was performed

# DIAGNOSTIC TROUBLE CODE (DTC) DETECTING CRITERIA

GENERAL DESCRIPTION

---

## 7. MALFUNCTION INDICATOR LIGHT CLEAR CONDITION

- When the OK driving cycle is completed 3 times in a row
- When "Clear Memory" was performed

## 8. FAIL SAFE

Calculate the intake manifold pressure using the map figured by engine speed and throttle opening grid.

## 9. ECM OPERATION AT DTC SETTING

Memorize the freeze frame data. (For test mode \$02)

# DIAGNOSTIC TROUBLE CODE (DTC) DETECTING CRITERIA

## GENERAL DESCRIPTION

### L: DTC P0111 — INTAKE AIR TEMPERATURE CIRCUIT RANGE/PERFORMANCE —

#### 1. OUTLINE OF DIAGNOSIS

Detect the malfunction of intake air temperature sensor output property.

Judge NG when the intake air temperature is high regardless of the driving condition that the intake air temperature may be low.

#### 2. COMPONENT DESCRIPTION

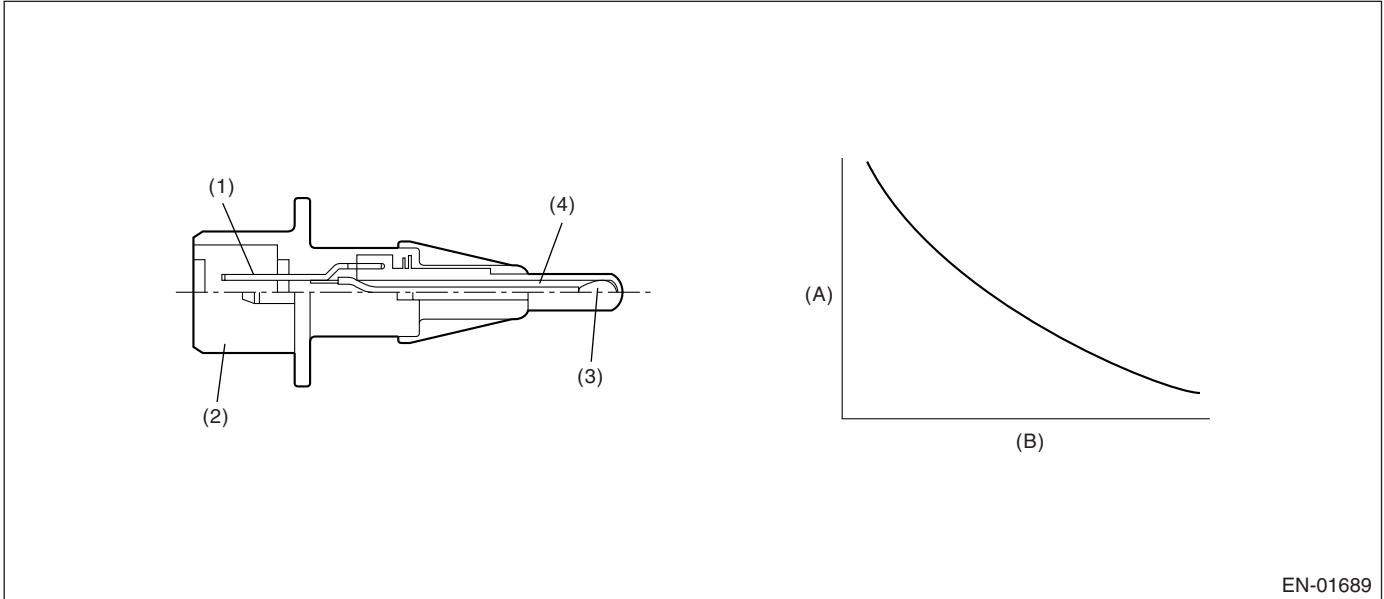

- (1) Terminal
- (2) Connector
- (3) Thermistor
- (4) Housing

- (A) Resistance value ( $\Omega$ )
- (B) Intake air temperature °C (°F)

#### 3. ENABLE CONDITION

Secondary Parameters	Enable Conditions
Ignition switch	ON

#### 4. GENERAL DRIVING CYCLE

Always perform the diagnosis continuously.



# DIAGNOSTIC TROUBLE CODE (DTC) DETECTING CRITERIA

GENERAL DESCRIPTION

## 5. DIAGNOSTIC METHOD

### • Abnormality Judgment

Judge NG when the continuous time until completing all the malfunction criteria below becomes more than the time (3 seconds) needed for diagnosis.

### Judgment Value

Malfunction Criteria	Threshold Value
Engine coolant temperature	< 40°C (104°F)
Fuel temperature	< 40°C (104°F)
Fuel level	10 ℓ (2.6 US gal, 2.2 Imp gal)
Intake air temperature	≥ 80°C (176°F)

**Time Needed for Diagnosis:** 3 seconds

**Malfunction Indicator Light Illumination:** Illuminates when malfunction occurs in 2 continuous driving cycles.

### • Normality Judgment

Judge OK and clear the NG when the malfunction criteria below are completed.

### Judgment Value

Malfunction Criteria	Threshold Value
Intake air temperature	< 80°C (176°F)

## 6. DTC CLEAR CONDITION

- When the OK idling cycle is completed 40 times in a row
- When "Clear Memory" was performed

## 7. MALFUNCTION INDICATOR LIGHT CLEAR CONDITION

- When the OK driving cycle is completed 3 times in a row
- When "Clear Memory" was performed

## 8. FAIL SAFE

Make the intake air temperature 40°C (104°F).

## 9. ECM OPERATION AT DTC SETTING

Memorize the freeze frame data. (For test mode \$02)

# DIAGNOSTIC TROUBLE CODE (DTC) DETECTING CRITERIA

## GENERAL DESCRIPTION

### M: DTC P0112 — INTAKE AIR TEMPERATURE CIRCUIT LOW INPUT —

#### 1. OUTLINE OF DIAGNOSIS

Detect the open or short circuit of intake air temperature sensor.  
Judge NG when out of the standard value.

#### 2. COMPONENT DESCRIPTION

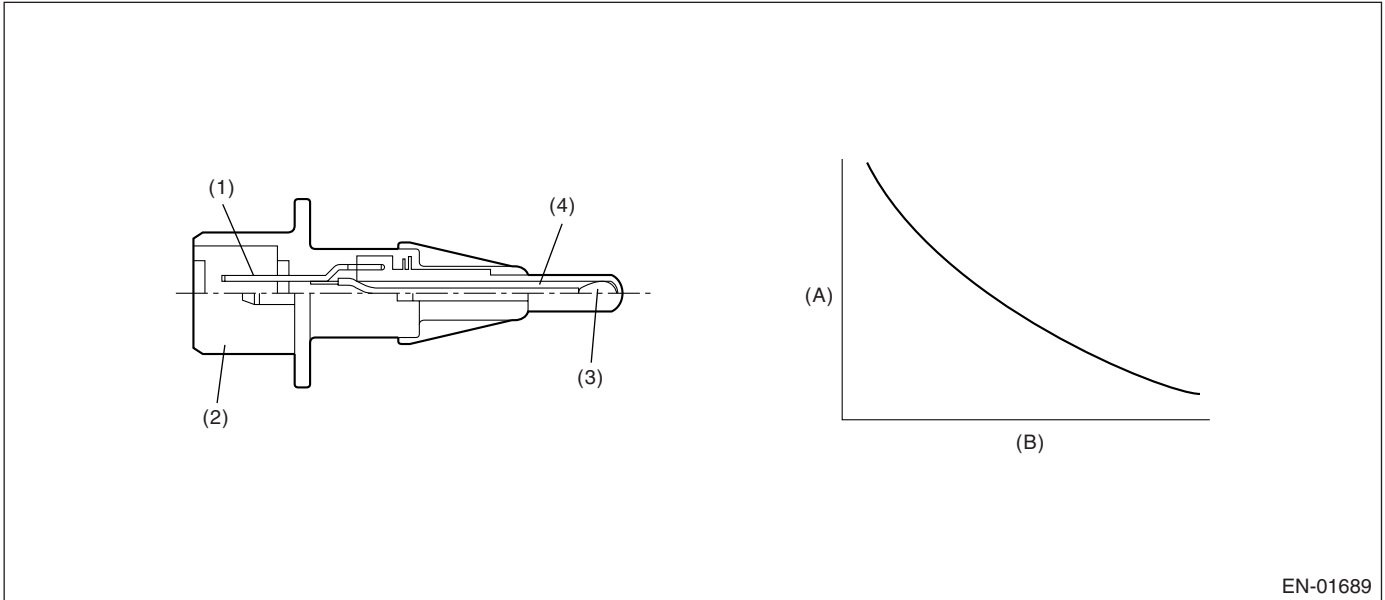

- (1) Terminal
- (2) Connector
- (3) Thermistor
- (4) Housing

- (A) Resistance value ( $\Omega$ )
- (B) Intake air temperature °C (°F)

EN-01689

#### 3. ENABLE CONDITION

Secondary Parameters	Enable Conditions
Ignition switch	ON

#### 4. GENERAL DRIVING CYCLE

Always perform the diagnosis continuously.

#### 5. DIAGNOSTIC METHOD

Judge NG when the continuous time until completing the malfunction criteria below becomes more than the time (2.5 seconds) needed for diagnosis. Judge fail safe NG when the continuous time until completing the malfunction criteria below becomes more than the time (0.1 seconds) needed for diagnosis. Judge OK and clear the NG when the malfunction criteria below are not completed.

##### Judgment Value

Malfunction Criteria	Threshold Value
Output voltage	$\leq 0.1$ V

**Time Needed for Diagnosis:** 2.5 seconds

**Malfunction Indicator Light Illumination:** Illuminates as soon as malfunction occurs.

# DIAGNOSTIC TROUBLE CODE (DTC) DETECTING CRITERIA

GENERAL DESCRIPTION

---

## 6. DTC CLEAR CONDITION

- When the OK idling cycle is completed 40 times in a row
- When "Clear Memory" was performed

## 7. MALFUNCTION INDICATOR LIGHT CLEAR CONDITION

- When the OK driving cycle is completed 3 times in a row
- When "Clear Memory" was performed

## 8. FAIL SAFE

Make the intake air temperature 40°C (104°F).

## 9. ECM OPERATION AT DTC SETTING

Memorize the freeze frame data. (For test mode \$02)

# DIAGNOSTIC TROUBLE CODE (DTC) DETECTING CRITERIA

## GENERAL DESCRIPTION

### N: DTC P0113 — INTAKE AIR TEMPERATURE CIRCUIT HIGH INPUT —

#### 1. OUTLINE OF DIAGNOSIS

Detect the open or short circuit of intake air temperature sensor.  
Judge NG when out of the standard value.

#### 2. COMPONENT DESCRIPTION

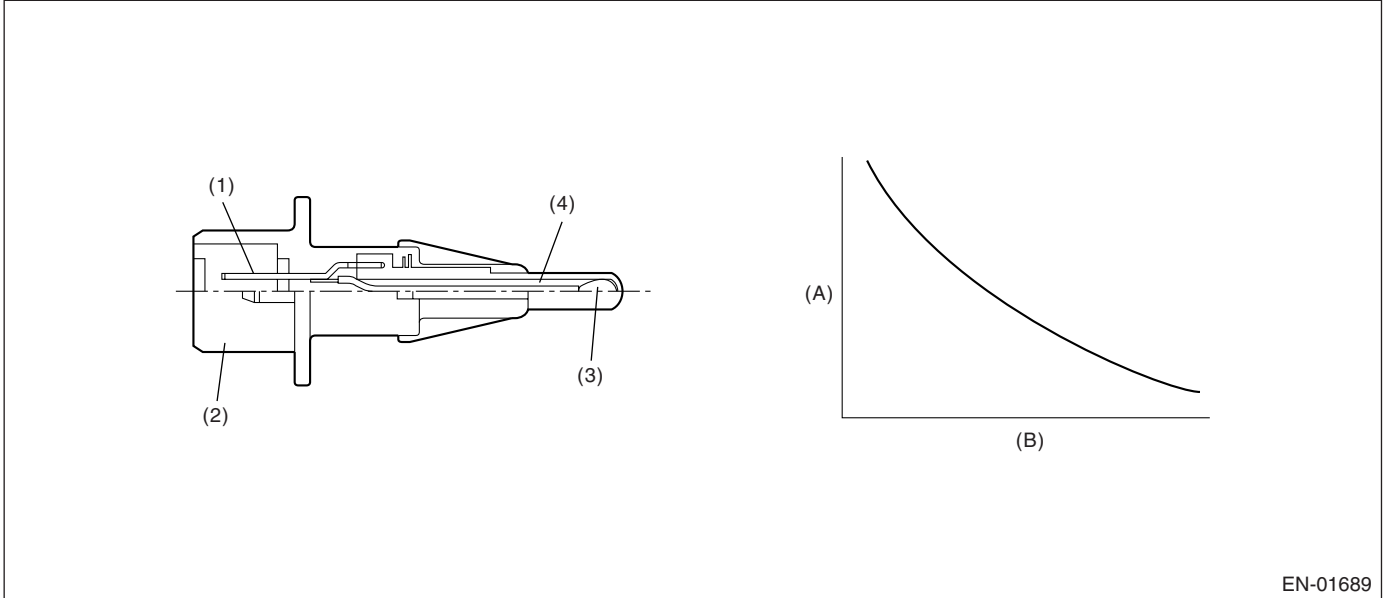

- (1) Terminal
- (2) Connector
- (3) Thermistor
- (4) Housing

- (A) Resistance value ( $\Omega$ )
- (B) Intake air temperature  $^{\circ}\text{C}$  ( $^{\circ}\text{F}$ )

#### 3. ENABLE CONDITION

Secondary Parameters	Enable Conditions
Ignition switch	ON

#### 4. GENERAL DRIVING CYCLE

Always perform the diagnosis continuously.

#### 5. DIAGNOSTIC METHOD

Judge NG when the continuous time until completing the malfunction criteria below becomes more than the time (2.5 seconds) needed for diagnosis. Judge fail safe NG when the continuous time until completing the malfunction criteria below becomes more than the time (0.1 seconds) needed for diagnosis. Judge OK and clear the NG when the malfunction criteria below are not completed.

##### Judgment Value

Malfunction Criteria	Threshold Value
Output voltage	> 4.85 V

**Time Needed for Diagnosis:** 2.5 seconds

**Malfunction Indicator Light Illumination:** Illuminates as soon as malfunction occurs.

# DIAGNOSTIC TROUBLE CODE (DTC) DETECTING CRITERIA

GENERAL DESCRIPTION

---

## 6. DTC CLEAR CONDITION

- When the OK idling cycle is completed 40 times in a row
- When "Clear Memory" was performed

## 7. MALFUNCTION INDICATOR LIGHT CLEAR CONDITION

- When the OK driving cycle is completed 3 times in a row
- When "Clear Memory" was performed

## 8. FAIL SAFE

Make the intake air temperature 40°C (104°F).

## 9. ECM OPERATION AT DTC SETTING

Memorize the freeze frame data. (For test mode \$02)

# DIAGNOSTIC TROUBLE CODE (DTC) DETECTING CRITERIA

## GENERAL DESCRIPTION

### O: DTC P0117 — ENGINE COOLANT TEMPERATURE CIRCUIT LOW INPUT —

#### 1. OUTLINE OF DIAGNOSIS

Detect the open or short circuit of engine coolant temperature sensor.  
Judge NG when out of the standard value.

#### 2. COMPONENT DESCRIPTION

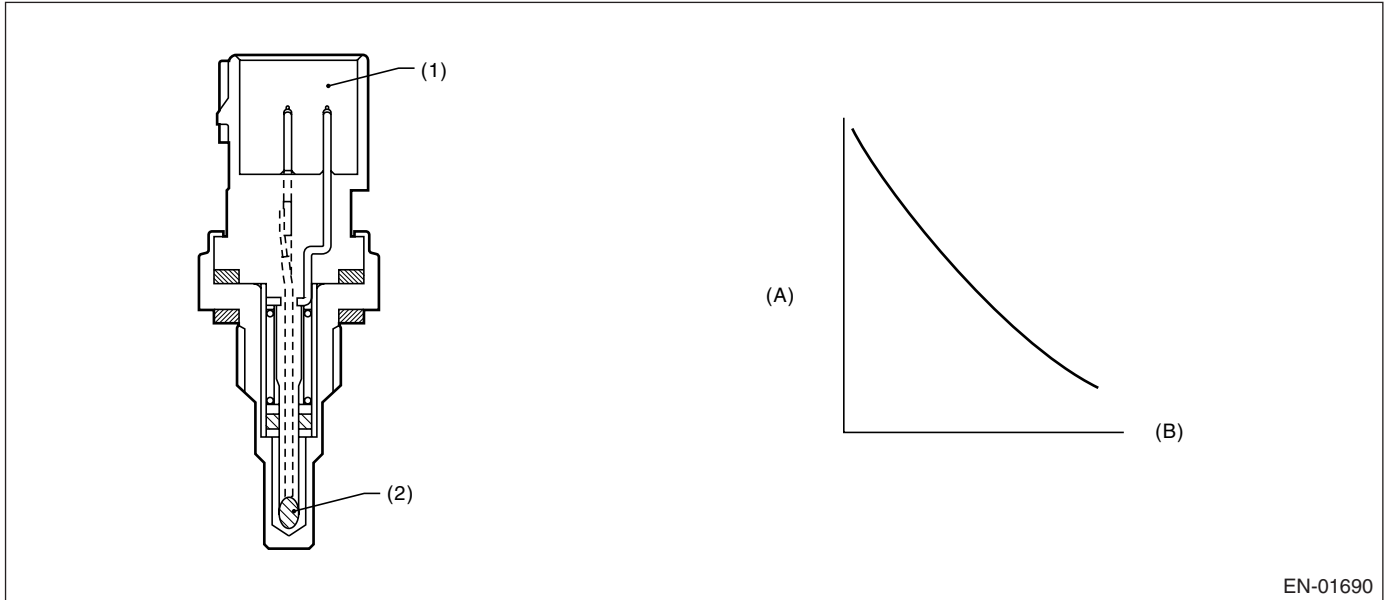

- (1) Connector
- (2) Thermistor element

- (A) Resistance value (kΩ)
- (B) Temperature °C (°F)

EN-01690

#### 3. ENABLE CONDITION

Secondary Parameters	Enable Conditions
None	

#### 4. GENERAL DRIVING CYCLE

Always perform the diagnosis continuously.

#### 5. DIAGNOSTIC METHOD

Judge NG when the continuous time until completing the malfunction criteria below becomes more than the time (2.5 seconds) needed for diagnosis.

Judge fail safe NG when the continuous time until completing the malfunction criteria below becomes more than the time (0.2 seconds) needed for diagnosis. Judge OK and clear the NG when the malfunction criteria below are not completed.

##### Judgment Value

Malfunction Criteria	Threshold Value
Output voltage	$\leq 0.1$ V

**Time Needed for Diagnosis:** 2.5 seconds

**Malfunction Indicator Light Illumination:** Illuminates as soon as malfunction occurs.

# DIAGNOSTIC TROUBLE CODE (DTC) DETECTING CRITERIA

GENERAL DESCRIPTION

---

## 6. DTC CLEAR CONDITION

- When the OK idling cycle was completed 40 times in a row
- When "Clear Memory" was performed

## 7. MALFUNCTION INDICATOR LIGHT CLEAR CONDITION

- When the OK driving cycle was completed 3 times in a row
- When "Clear Memory" was performed

## 8. FAIL SAFE

Keep the engine coolant temperature at 70°C (158°F).

## 9. ECM OPERATION AT DTC

Memorize the freeze frame data. (For test mode \$02)

# DIAGNOSTIC TROUBLE CODE (DTC) DETECTING CRITERIA

## GENERAL DESCRIPTION

### P: DTC P0118 — ENGINE COOLANT TEMPERATURE CIRCUIT HIGH INPUT —

#### 1. OUTLINE OF DIAGNOSIS

Detect the open or short circuit of engine coolant temperature sensor.  
Judge NG when out of the standard value.

#### 2. COMPONENT DESCRIPTION

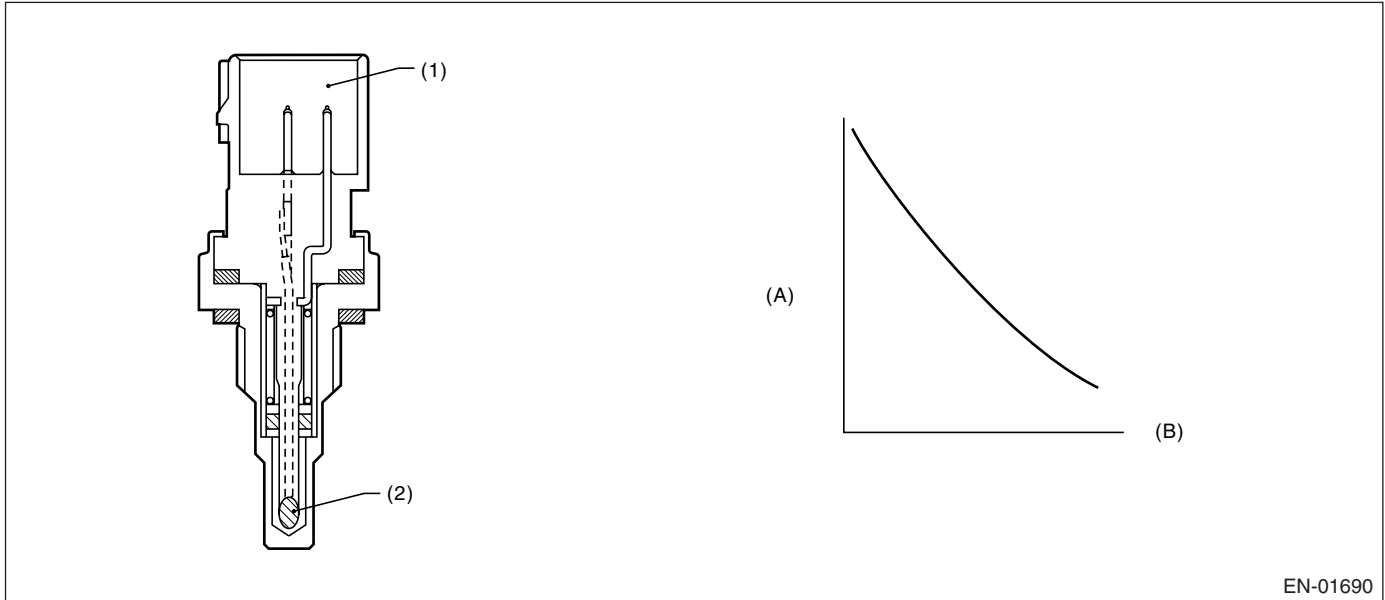

- (1) Connector
- (2) Thermistor element

- (A) Resistance value (kΩ)
- (B) Temperature °C (°F)

EN-01690

#### 3. ENABLE CONDITION

Secondary Parameters	Enable Conditions
None	

#### 4. GENERAL DRIVING CYCLE

Always perform the diagnosis continuously.

#### 5. DIAGNOSTIC METHOD

Judge NG when the continuous time until completing the malfunction criteria below becomes more than the time (2.5 seconds) needed for diagnosis.

Judge fail safe NG when the continuous time until completing the malfunction criteria below becomes more than the time (0.2 seconds) needed for diagnosis. Judge OK and clear the NG when the malfunction criteria below are not completed.

##### Judgment Value

Malfunction Criteria	Threshold Value
Output voltage	≥ 4.85 V

**Time Needed for Diagnosis:** 2.5 seconds

**Malfunction Indicator Light Illumination:** Illuminates as soon as malfunction occurs.



# DIAGNOSTIC TROUBLE CODE (DTC) DETECTING CRITERIA

GENERAL DESCRIPTION

---

## 6. DTC CLEAR CONDITION

- When the OK idling cycle was completed 40 times in a row
- When "Clear Memory" was performed

## 7. MALFUNCTION INDICATOR LIGHT CLEAR CONDITION

- When the OK driving cycle was completed 3 times in a row
- When "Clear Memory" was performed

## 8. FAIL SAFE

Keep the engine coolant temperature at 70°C (158°F).

## 9. ECM OPERATION AT DTC

Memorize the freeze frame data. (For test mode \$02)

# DIAGNOSTIC TROUBLE CODE (DTC) DETECTING CRITERIA

## GENERAL DESCRIPTION

### Q: DTC P0121 — THROTTLE/PEDAL POSITION SENSOR/SWITCH “A” CIRCUIT RANGE/PERFORMANCE —

#### 1. OUTLINE OF DIAGNOSIS

Detect the malfunction of throttle position sensor output property.

Judge NG when the throttle position value is low in spite of the driving condition that accelerator pedal seems to be depressed, or when the throttle position value is high in spite of the driving condition that accelerator pedal seems to be released from engine appearance.

#### 2. COMPONENT DESCRIPTION

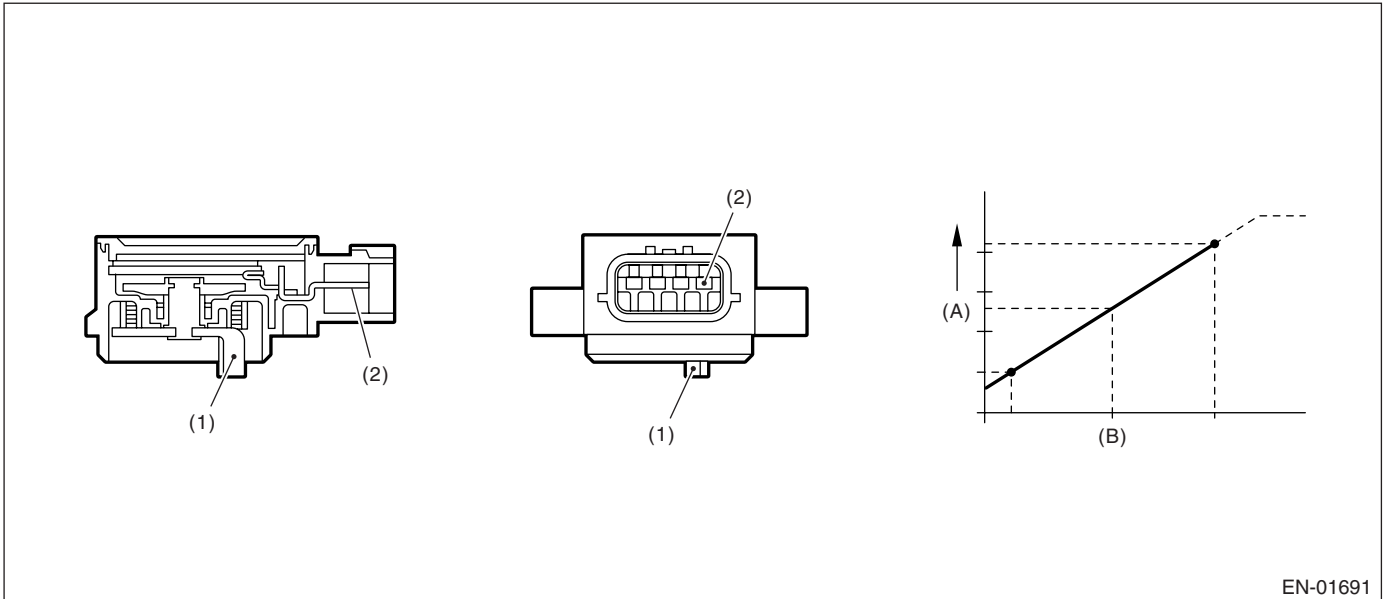

- (1) Lever
- (2) Terminal

- (A) Output voltage
- (B) Throttle angle

EN-01691

#### 3. ENABLE CONDITION

Secondary Parameters	Enable Conditions
Coolant temperature	$\geq 75^{\circ}\text{C}$ ( $167^{\circ}\text{F}$ )

#### 4. GENERAL DRIVE CYCLE

Perform the diagnosis continuously after starting engine.

# DIAGNOSTIC TROUBLE CODE (DTC) DETECTING CRITERIA

GENERAL DESCRIPTION

## 5. DIAGNOSTIC METHOD

### • Abnormality Judgment

Judge NG when the continuous time of completing the malfunction criteria of Low side or High side below becomes more than time needed for diagnosis.

### Judgment Value

Malfunction Criteria	Threshold Value
(Low side)	
Output voltage	$\leq 0.75$ V
Engine speed	$\geq 1,000$ rpm
Amount of intake air	$\geq 90$ kg/h
Intake manifold pressure	$\geq 80$ kPa (600 mmHg, 24 inHg)
(High side)	
Output voltage	$\geq 1.6$ V
Engine speed	600 — 1,500 rpm
Amount of intake air	$\leq 25$ kg/h
Intake manifold pressure	$\leq 47$ kPa (352 mmHg, 14 inHg)

### Time Needed for Diagnosis:

Low side	3 seconds
High side	10 seconds

**Malfunction Indicator Light Illumination:** Illuminates when malfunction occurs in 2 continuous driving cycles.

### • Normality Judgment

Judge OK and clear the NG when the malfunction criteria below are completed.

### Judgment Value

Malfunction Criteria	Threshold Value
(Low side)	
Output voltage	$> 0.75$ V
Engine speed	$\geq 1,000$ rpm
Amount of intake air	$\geq 90$ kg/h
Intake manifold pressure	$\geq 80$ kPa (600 mmHg, 24 inHg)
(High side)	
Output voltage	$\leq 1.6$ V
Engine speed	600 — 1,500 rpm
Amount of intake air	$\leq 25$ kg/h
Intake manifold pressure	$\leq 47$ kPa (352 mmHg, 14 inHg)

## 6. DTC CLEAR CONDITION

- When the OK idling cycle is completed 40 times in a row
- When "Clear Memory" was performed

## 7. MALFUNCTION INDICATOR LIGHT CLEAR CONDITION

- When the OK driving cycle was completed 3 times in a row
- When "Clear Memory" was performed

## 8. FAIL SAFE

Fix the throttle position to 6.4°.

## 9. ECM OPERATION AT DTC

Memorize the freeze frame data. (For test mode \$02)

# DIAGNOSTIC TROUBLE CODE (DTC) DETECTING CRITERIA

## GENERAL DESCRIPTION

### R: DTC P0122 — THROTTLE/PEDAL POSITION SENSOR/SWITCH “A” CIRCUIT LOW INPUT —

#### 1. OUTLINE OF DIAGNOSIS

Detect the open or short circuit of throttle position sensor.  
Judge NG when out of the standard value.

#### 2. COMPONENT DESCRIPTION

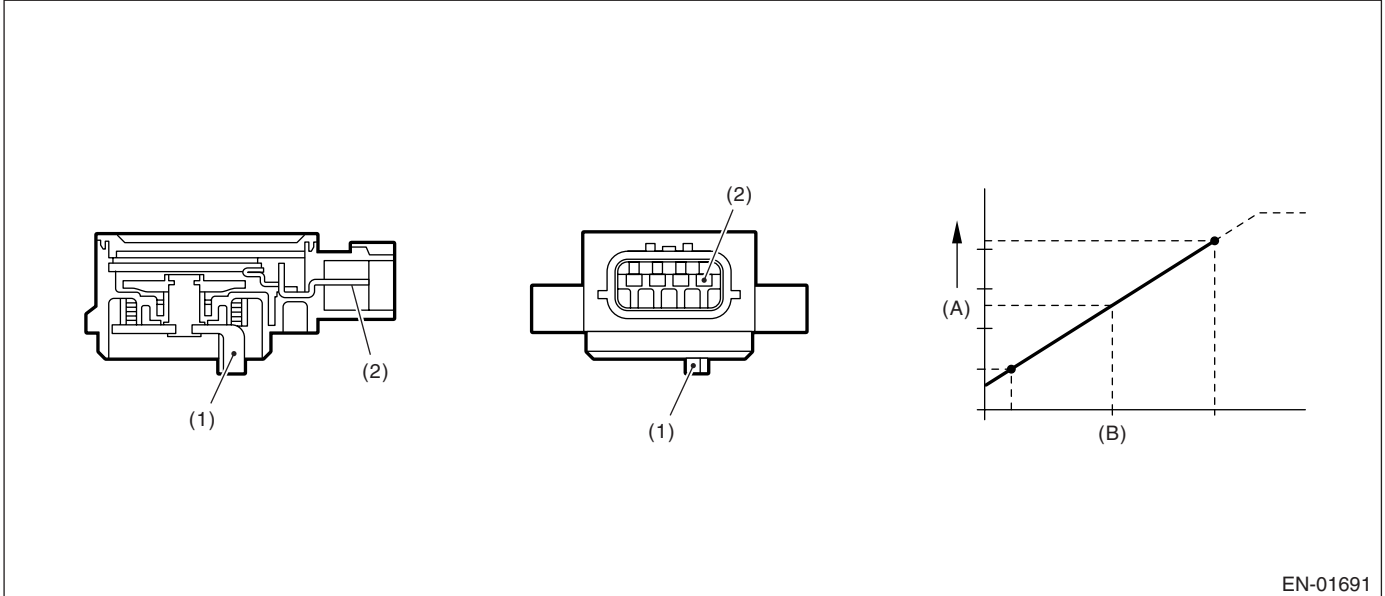

- (1) Lever
- (2) Terminal

- (A) Output voltage
- (B) Throttle angle

EN-01691

#### 3. ENABLE CONDITION

Secondary Parameters	Enable Conditions
Ignition switch	ON

#### 4. GENERAL DRIVE CYCLE

Always perform the diagnosis continuously.

#### 5. DIAGNOSTIC METHOD

Judge NG when the continuous time until completing the malfunction criteria below becomes more than the time (2.5 seconds) needed for diagnosis.

Judge fail safe NG when the continuous time until completing the malfunction criteria below becomes more than the time (0.1 seconds) needed for diagnosis. Judge OK and clear the NG when the malfunction criteria below are completed.

##### Judgment Value

Malfunction Criteria	Threshold Value
Output voltage — Closed	$\leq 0.1$ V

**Time Needed for Diagnosis:** 2.5 seconds

**Malfunction Indicator Light Illumination:** Illuminates as soon as malfunction occurs.

#### 6. DTC CLEAR CONDITION

- When the OK idling cycle is completed 40 times in a row
- When “Clear Memory” was performed

# DIAGNOSTIC TROUBLE CODE (DTC) DETECTING CRITERIA

GENERAL DESCRIPTION

---

## 7. MALFUNCTION INDICATOR LIGHT CLEAR CONDITION

- When the OK driving cycle was completed 3 times in a row
- When "Clear Memory" was performed

## 8. FAIL SAFE

Fix the throttle position to 6.4°.

## 9. ECM OPERATION AT DTC

Memorize the freeze frame data. (For test mode \$02)

# DIAGNOSTIC TROUBLE CODE (DTC) DETECTING CRITERIA

## GENERAL DESCRIPTION

### S: DTC P0123 — THROTTLE/PEDAL POSITION SENSOR/SWITCH “A” CIRCUIT HIGH INPUT —

#### 1. OUTLINE OF DIAGNOSIS

Detect the open or short circuit of throttle position sensor.  
Judge NG when out of the standard value.

#### 2. COMPONENT DESCRIPTION

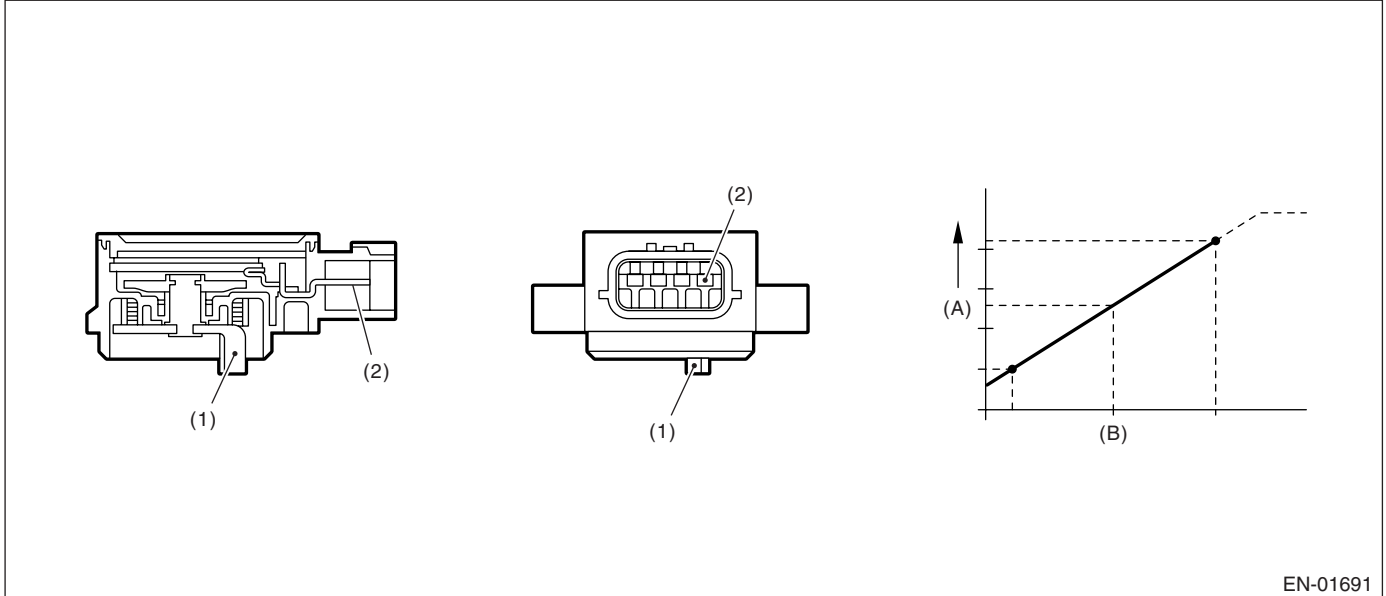

- (1) Lever
- (2) Terminal

- (A) Output voltage
- (B) Throttle angle

EN-01691

#### 3. ENABLE CONDITION

Secondary Parameters	Enable Conditions
Ignition switch	ON

#### 4. GENERAL DRIVE CYCLE

Always perform the diagnosis continuously.

#### 5. DIAGNOSTIC METHOD

Judge NG when the continuous time until completing the malfunction criteria below becomes more than the time (2.5 seconds) needed for diagnosis.

Judge fail safe NG when the continuous time until completing the malfunction criteria below becomes more than the time (0.1 seconds) needed for diagnosis. Judge OK and clear the NG when the malfunction criteria below are completed.

##### Judgment Value

Malfunction Criteria	Threshold Value
Output voltage — WOT	$\geq 4.9$ V

**Time Needed for Diagnosis:** 2.5 seconds

**Malfunction Indicator Light Illumination:** Illuminates as soon as malfunction occurs.

#### 6. DTC CLEAR CONDITION

- When the OK idling cycle is completed 40 times in a row
- When “Clear Memory” was performed

# DIAGNOSTIC TROUBLE CODE (DTC) DETECTING CRITERIA

GENERAL DESCRIPTION

---

## 7. MALFUNCTION INDICATOR LIGHT CLEAR CONDITION

- When the OK driving cycle was completed 3 times in a row
- When "Clear Memory" was performed

## 8. FAIL SAFE

Fix the throttle position to 6.4°.

## 9. ECM OPERATION AT DTC

Memorize the freeze frame data. (For test mode \$02)

# DIAGNOSTIC TROUBLE CODE (DTC) DETECTING CRITERIA

## GENERAL DESCRIPTION

### T: DTC P0125 — INSUFFICIENT COOLANT TEMPERATURE FOR CLOSED LOOP FUEL CONTROL —

#### 1. OUTLINE OF DIAGNOSIS

Detect the malfunction of engine coolant temperature sensor output property.

Judge NG when the engine coolant temperature does not increase after engine starting in spite of the driving condition that it seems to increase.

#### 2. ENABLE CONDITION

Secondary Parameters	Enable Conditions
None	

#### 3. GENERAL DRIVE CYCLE

Always perform the diagnosis until the engine coolant temperature becomes 20°C (68°F) after starting engine with cooled condition or until NG is judged once.

#### 4. DIAGNOSTIC METHOD

Judge NG when the malfunction criteria below are completed. Judge OK and clear NG when the engine coolant temperature is more than 20°C (68°F) or more.

##### Judgment Value

Malfunction Criteria	Threshold Value
Timer after starting the engine (except for the fuel cut) a) Timer stop of fuel cut mode b) Timer is counted more than 50 ms + TWCNT ms per 50 ms during driving conditions except a).TWCNT is determined as shown below. • Idling switch ON: TWCNT = 0 • Idling switch OFF: See Map 1.	≥ Judgment time

##### Map 1

Unit: ms		Vehicle speed			
		10 km/h (6 MPH)	24 km/h (15 MPH)	40 km/h (25 MPH)	56 km/h (35 MPH)
Air temperature	-20 °C (-4 °F)	0	5	10	20
	-7 °C (19 °F)	0	30	60	60
	10 °C (50 °F)	0	90	180	180
	20 °C (68 °F)	0	90	180	180

**Judgment time: Find from minimum engine coolant temperature.**

Minimum engine coolant temperature °C (°F)	-30 (-22)	0 (32)	30 (86)	60 (140)	64.25 (147.65)
Judgment time (second)	630.05	429.5	228.95	28.4	0

**Time Needed for Diagnosis:** Change at minimum engine coolant temperature.

**Malfunction Indicator Light Illumination:** Illuminates when malfunction occurs in 2 continuous driving cycles.

#### 5. DTC CLEAR CONDITION

- When the OK idling cycle was completed 40 times in a row
- When "Clear Memory" was performed



# DIAGNOSTIC TROUBLE CODE (DTC) DETECTING CRITERIA

GENERAL DESCRIPTION

---

## 6. MALFUNCTION INDICATOR LIGHT CLEAR CONDITION

- When the OK driving cycle was completed 3 times in a row
- When "Clear Memory" was performed

## 7. FAIL SAFE

Keep engine coolant temperature at 70°C (158°F).

## 8. ECM OPERATION AT DTC

Memorize the freeze frame data. (For test mode \$02)

# DIAGNOSTIC TROUBLE CODE (DTC) DETECTING CRITERIA

## GENERAL DESCRIPTION

### U: DTC P0128 — COOLANT THERMOSTAT (COOLANT TEMPERATURE BELOW THERMOSTAT REGULATING TEMPERATURE) —

#### 1. OUTLINE OF DIAGNOSIS

Detect the malfunction of thermostat.

Thermostat open fixing may result in overcooling. Therefore, engine coolant temperature becomes low and the control is unable under theoretical air fuel ratio, so the exhaust deteriorate. Furthermore, it is impossible to perform the other diagnosis if the engine coolant temperature does not rise. For these reasons, thermostat open fixing diagnosis should be conducted.

Judge NG when the estimated engine coolant temperature is higher than engine coolant temperature and the difference between them is large. Judge OK when the engine coolant temperature becomes 75°C (167°F) before judging NG.

#### 2. COMPONENT DESCRIPTION

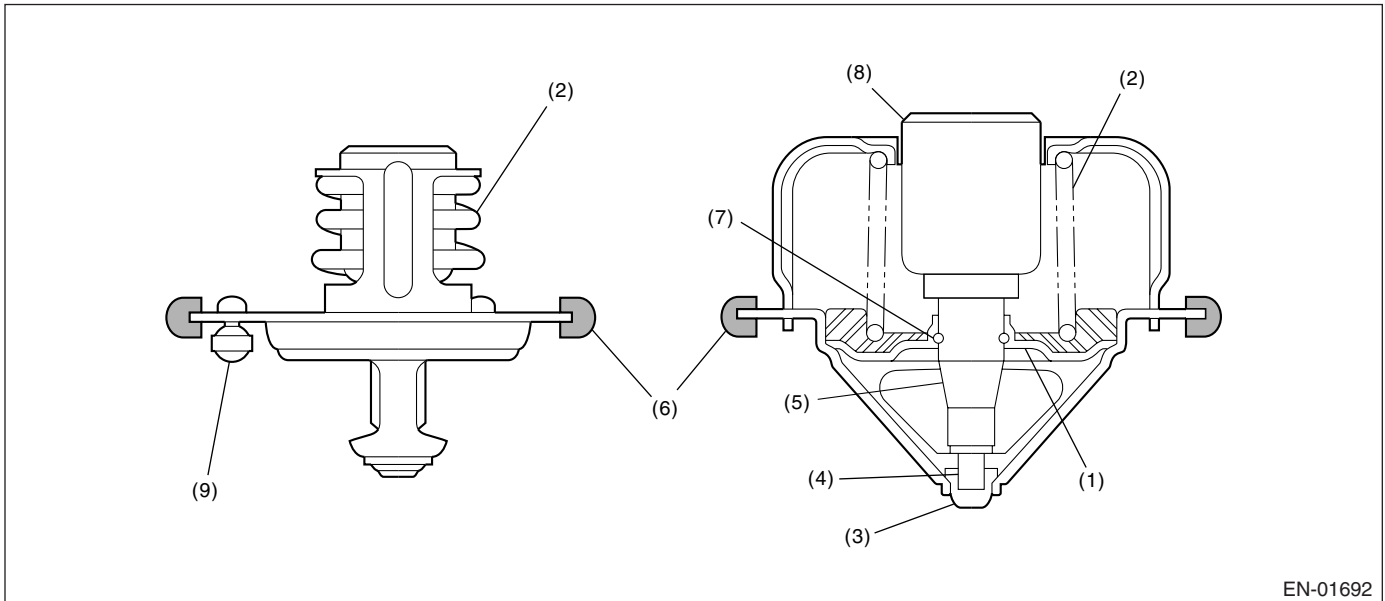

- (1) Valve
- (2) Spring
- (3) Stopper
- (4) Piston
- (5) Guide

- (6) Rubber packing
- (7) Stop ring
- (8) Wax element
- (9) Jiggle valve

#### 3. ENABLE CONDITION

Secondary Parameters	Enable Conditions
Ambient air temperature	$\geq -7^{\circ}\text{C}$ (19°F)
Engine coolant temperature at engine starting	$< 55^{\circ}\text{C}$ (131°F)

#### 4. GENERAL DRIVING CYCLE

After starting the engine at cool condition, always perform the diagnosis until the engine coolant temperature becomes more than 75°C (167°F).

#### 5. DIAGNOSTIC METHOD

Judge NG when the estimated engine coolant temperature comes to 75°C (167°F) before the engine coolant temperature becomes 75°C (167°F) and the difference between them becomes more than 30°C (86°F). Judge OK when the engine coolant temperature comes to 75°C (167°F) before judging NG.

# DIAGNOSTIC TROUBLE CODE (DTC) DETECTING CRITERIA

GENERAL DESCRIPTION

## • Abnormality Judgment

Judge NG when the cumulative time becomes more than 30 seconds after completing all the malfunction criteria below.

### Judgment Value

Malfunction Criteria	Threshold Value
(Estimated-measured) coolant temperature	> 30°C (86°F)
Engine coolant temperature	< 75°C (167°F)
Estimated coolant temperature	≥ 75°C (167°F)
Vehicle speed	≥ 40 km/h (25 MPH)
Injector pulse	≥ 1.92 milliseconds

**Time Needed for Diagnosis:** 30 seconds

**Malfunction Indicator Light Illumination:** Illuminates when malfunction occurs in 2 continuous driving cycles.

## • Normality Judgment

Judge OK and clear the NG when all the malfunction criteria below are completed.

### Judgment Value

Malfunction Criteria	Threshold Value
(Estimated-measured) coolant temperature	≤ 30°C (86°F)
Engine coolant temperature	≥ 75°C (167°F)

## 6. DTC CLEAR CONDITION

- When the OK idling cycle is completed 40 times in a row
- When "Clear Memory" was performed

## 7. MALFUNCTION INDICATOR LIGHT CLEAR CONDITION

- When the OK driving cycle is completed 3 times in a row
- When "Clear Memory" was performed

## 8. FAIL SAFE

None

## 9. ECM OPERATION AT DTC SETTING

- Memorize the freeze frame data. (For test mode \$02)
- Memorize the diagnostic value and trouble standard value. (For test mode \$06)

# DIAGNOSTIC TROUBLE CODE (DTC) DETECTING CRITERIA

## GENERAL DESCRIPTION

### V: DTC P0129 — BAROMETRIC PRESSURE TOO LOW —

#### 1. OUTLINE OF DIAGNOSIS

Detect the malfunction of atmospheric pressure sensor output property.

Intake manifold pressure and atmospheric pressure are the same from turning the IG key to ON to turning the start SW to ON. Therefore, compare the pressure from intake manifold pressure and atmospheric pressure sensors, and then judge NG when their difference is large.

#### 2. COMPONENT DESCRIPTION

Atmospheric pressure sensor is built in ECM.

#### 3. ENABLE CONDITION

Secondary Parameters	Enable Conditions
Ignition switch	ON
Neutral switch	ON
Engine speed	< 500 rpm
Vehicle speed	< 2 km/h (1 MPH)
(Max-min) manifold absolute pressure output	< 1.2 kPa (9 mmHg, 0.4 inHg)

#### 4. GENERAL DRIVING CYCLE

Perform the diagnosis only once from the IG key turned to ON to the start SW turned to ON.

#### 5. DIAGNOSTIC METHOD

Judge NG when the continuous time until completing the malfunction criteria below becomes more than the time (0.2 seconds) needed for diagnosis. Judge OK when the malfunction criteria below are not completed.

##### Judgment Value

Malfunction Criteria	Threshold Value
Atmospheric-manifold absolute pressure	≥ 27 kPa (200 mmHg, 8 inHg)

**Time Needed for Diagnosis:** 0.2 seconds

**Malfunction Indicator Light Illumination:** Illuminates when malfunction occurs in 2 continuous driving cycles.

#### 6. DTC CLEAR CONDITION

- When the OK idling cycle is completed 40 times in a row
- When "Clear Memory" was performed

#### 7. MALFUNCTION INDICATOR LIGHT CLEAR CONDITION

- When the OK driving cycle is completed 3 times in a row
- When "Clear Memory" was performed

#### 8. FAIL SAFE

Make the atmospheric pressure 101 kPa (760 mmHg, 29.8 inHg).

#### 9. ECM OPERATION AT DTC SETTING

Memorize the freeze frame data. (For test mode \$02)

# DIAGNOSTIC TROUBLE CODE (DTC) DETECTING CRITERIA

GENERAL DESCRIPTION

## W: DTC P0130 — O<sub>2</sub> SENSOR CIRCUIT (BANK 1 SENSOR 1) —

### 1. OUTLINE OF DIAGNOSIS

Detect the malfunction of front oxygen (A/F) sensor output property.  
Judge NG when the front oxygen (A/F) sensor output continues to be lean.

### 2. COMPONENT DESCRIPTION

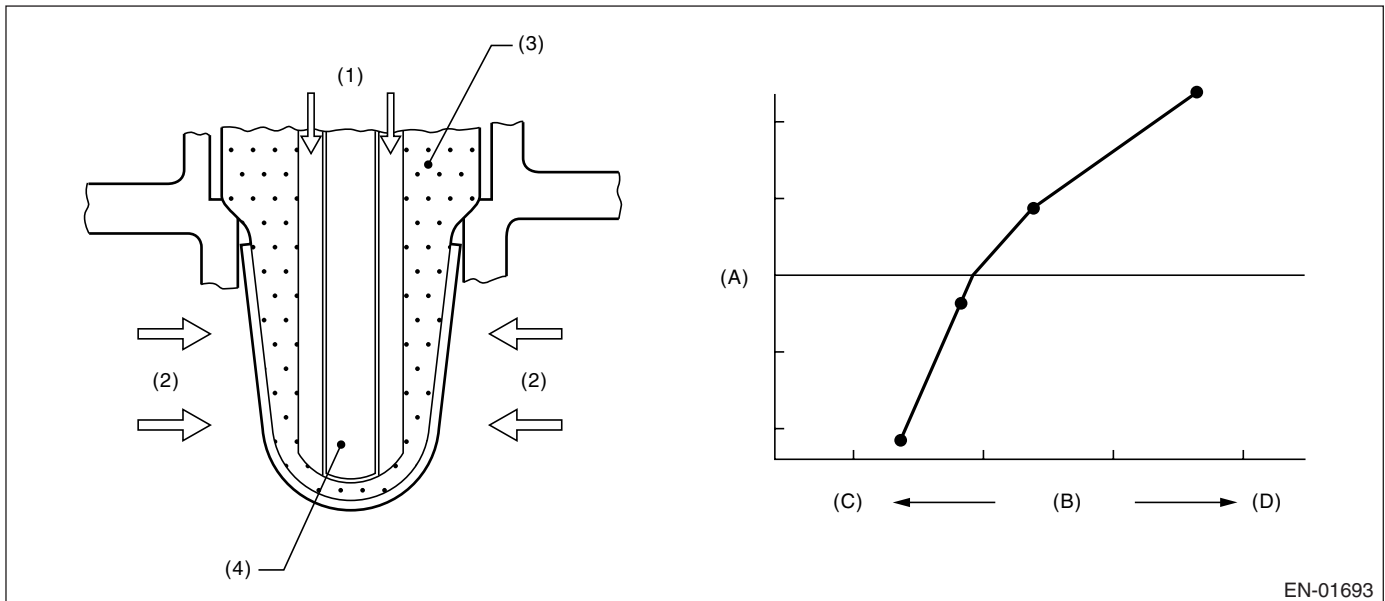

- (1) Atmosphere
- (2) Exhaust gas
- (3) ZrO<sub>2</sub>
- (4) Ceramic heater

- (A) Electromotive force
- (B) Air fuel ratio
- (C) Lean
- (D) Rich

EN-01693

### 3. ENABLE CONDITION

Secondary Parameters	Enable Conditions
Closed loop control	In operation
Fuel shut-off event	Not in operation
Misfire rate during 200 engine revs.	≤ 1.0%
After engine starting	230 seconds or more
Engine coolant temperature	≥ 75°C (167°F)

### 4. GENERAL DRIVING CYCLE

Perform the diagnosis continuously in 230 seconds after engine starting.

### 5. DIAGNOSTIC METHOD

#### • Abnormality Judgment

Judge NG when the continuous time of completing all the malfunction criteria below becomes more than the time (10 seconds) needed for diagnosis

#### Judgment Value

Malfunction Criteria	Threshold Value
A/F sensor output (VAF)	> 2.3 V (lean)
Lambda fudge factor (LAMBDA)	= Rich clamp at MAX limiter (1.375)

**Time Needed for Diagnosis:** 10 seconds

# DIAGNOSTIC TROUBLE CODE (DTC) DETECTING CRITERIA

## GENERAL DESCRIPTION

---

**Malfunction Indicator Light Illumination:** Illuminates as soon as malfunction occurs.

• **Normality Judgment**

Judge OK when the cumulative time until completing all the malfunction criteria below becomes more than the time (10 seconds) needed for diagnosis

**Judgment Value**

Malfunction Criteria	Threshold Value
A/F sensor output (VAF)	$\leq 2.3$ V

### 6. DTC CLEAR CONDITION

- When the OK idling cycle was completed 40 times in a row
- When "Clear Memory" was performed

### 7. MALFUNCTION INDICATOR LIGHT CLEAR CONDITION

- When the OK driving cycle was completed 3 times in a row
- When "Clear Memory" was performed

### 8. FAIL SAFE

None

### 9. ECM OPERATION AT DTC SETTING

Memorize the freeze frame data. (For test mode \$02)

# DIAGNOSTIC TROUBLE CODE (DTC) DETECTING CRITERIA

GENERAL DESCRIPTION

## X: DTC P0131 — O<sub>2</sub> SENSOR CIRCUIT LOW VOLTAGE (BANK 1 SENSOR 1) —

### 1. OUTLINE OF DIAGNOSIS

Detect the low voltage short circuit of front oxygen (A/F) sensor.

Diagnosis is performed using A/F microcomputer, and communication is established between A/F microcomputer and main microcomputer. Judge NG when the data of low voltage short circuit NG is transmitted.

### 2. COMPONENT DESCRIPTION

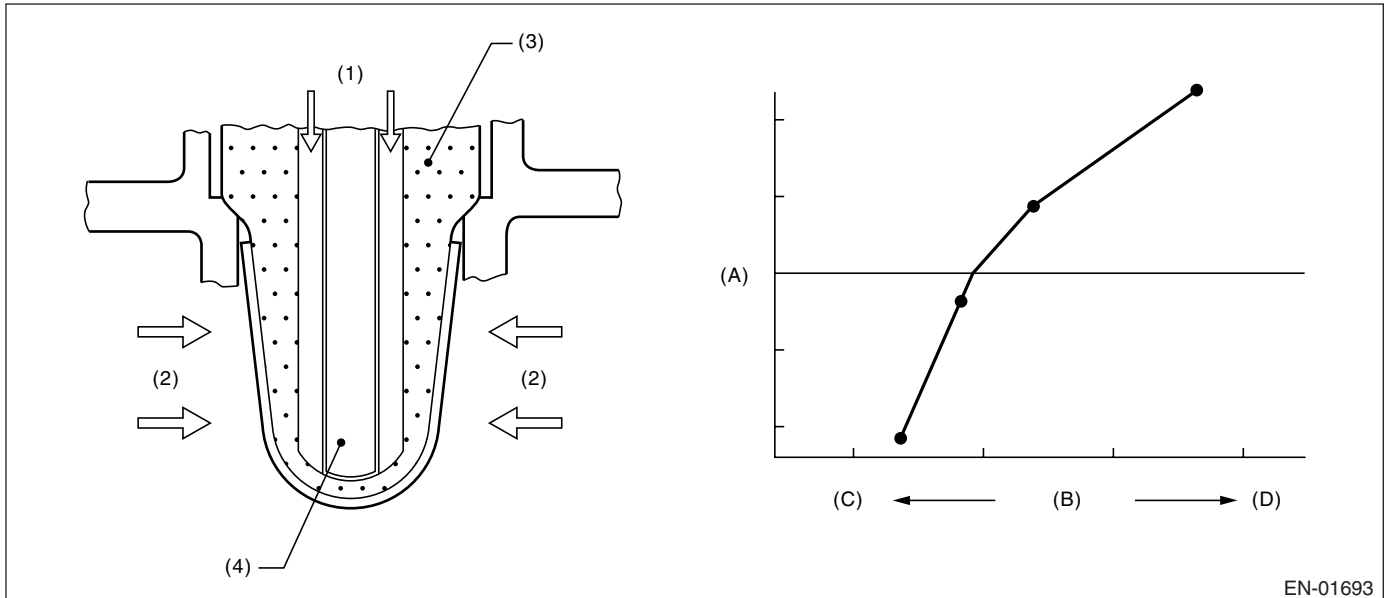

- (1) Atmosphere
- (2) Exhaust gas
- (3) ZrO<sub>2</sub>
- (4) Ceramic heater

- (A) Electromotive force
- (B) Air fuel ratio
- (C) Lean
- (D) Rich

EN-01693

### 3. ENABLE CONDITION

Secondary Parameters	Enable Conditions
None	

### 4. GENERAL DRIVING CYCLE

Terminate the diagnosis if the open circuit, low voltage short circuit or high voltage short circuit becomes NG once by performing diagnosis continuously.

### 5. DIAGNOSTIC METHOD

Judge NG when the malfunction criteria below is completed.

#### Judgment Value

Malfunction Criteria	Threshold Value
AFC	< 3.5 V
AFV	< 2.5 V

**Time Needed for Diagnosis:** 5 seconds

**Malfunction Indicator Light Illumination:** Illuminates as soon as malfunction occurs.

### 6. DTC CLEAR CONDITION

- When the OK idling cycle was completed 40 times in a row
- When "Clear Memory" was performed

# DIAGNOSTIC TROUBLE CODE (DTC) DETECTING CRITERIA

## GENERAL DESCRIPTION

---

### 7. MALFUNCTION INDICATOR LIGHT CLEAR CONDITION

- When the OK driving cycle was completed 3 times in a row
- When "Clear Memory" was performed

### 8. FAIL SAFE

None

### 9. ECM OPERATION AT DTC SETTING

Memorize the freeze frame data. (For test mode \$02)



# DIAGNOSTIC TROUBLE CODE (DTC) DETECTING CRITERIA

GENERAL DESCRIPTION

## Y: DTC P0132 — O<sub>2</sub> SENSOR CIRCUIT HIGH VOLTAGE (BANK 1 SENSOR 1) —

### 1. OUTLINE OF DIAGNOSIS

Detect the high voltage short circuit of front oxygen (A/F) sensor.

Diagnosis is performed using A/F microcomputer, and communication is established between A/F microcomputer and main microcomputer. Judge NG when the data of high voltage short circuit NG is transmitted.

### 2. COMPONENT DESCRIPTION

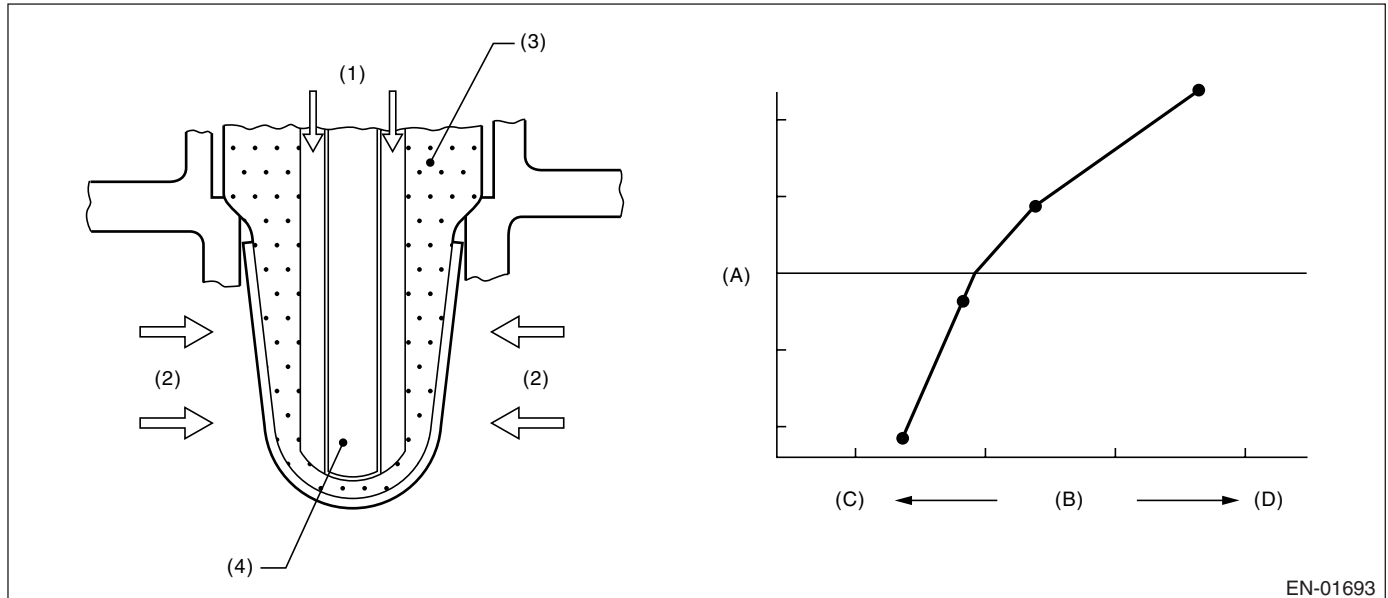

- (1) Atmosphere
- (2) Exhaust gas
- (3) ZrO<sub>2</sub>
- (4) Ceramic heater

- (A) Electromotive force
- (B) Air fuel ratio
- (C) Lean
- (D) Rich

### 3. ENABLE CONDITION

Secondary Parameters	Enable Conditions
None	

### 4. GENERAL DRIVING CYCLE

Terminate the diagnosis if the open circuit, low voltage short circuit or high voltage short circuit becomes NG once by performing diagnosis continuously.

### 5. DIAGNOSTIC METHOD

Judge NG when the continuous time until completing the malfunction criteria below becomes more than 5 seconds.

#### Judgment Value

Malfunction Criteria	Threshold Value
AFC	< 4.5 V
AFV	< 5.0 V

**Time Needed for Diagnosis:** 5 seconds

**Malfunction Indicator Light Illumination:** Illuminates as soon as malfunction occurs.

### 6. DTC CLEAR CONDITION

- When the OK idling cycle was completed 40 times in a row
- When "Clear Memory" was performed

# DIAGNOSTIC TROUBLE CODE (DTC) DETECTING CRITERIA

## GENERAL DESCRIPTION

---

### 7. MALFUNCTION INDICATOR LIGHT CLEAR CONDITION

- When the OK driving cycle was completed 3 times in a row
- When "Clear Memory" was performed

### 8. FAIL SAFE

None

### 9. ECM OPERATION AT DTC SETTING

Memorize the freeze frame data. (For test mode \$02)

## Z: DTC P0133 — O<sub>2</sub> SENSOR CIRCUIT SLOW RESPONSE (BANK 1 SENSOR 1)

### 1. OUTLINE OF DIAGNOSIS

Detect the slow response of front oxygen (A/F) sensor.

Front oxygen (A/F) sensor cover has some ventilation holes for exhaust gas. Clogged ventilation holes are diagnosed.

When the holes are clogged, the A/F output variation becomes slow comparing with the actual A/F variation because oxygen which reaches the zirconia layer is insufficient. Therefore, if the cover has clogged holes, the rich to lean judgment in ECM is delayed when the change from rich to lean is caused.

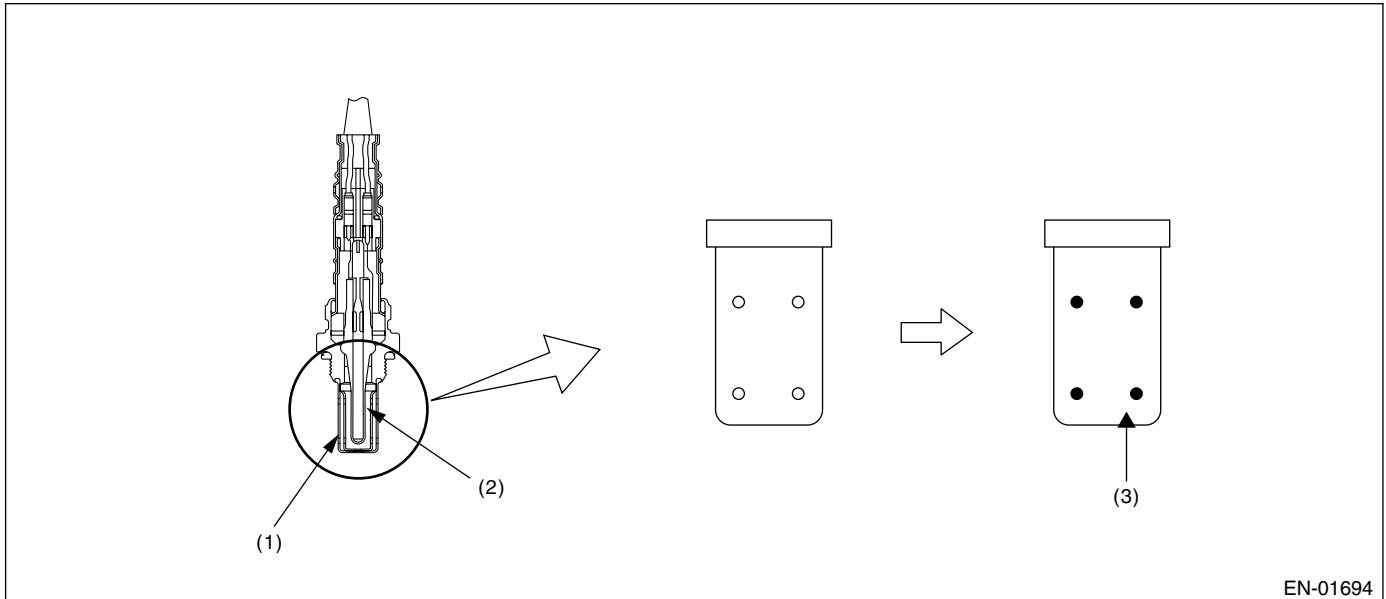

EN-01694

- (1) Cover
- (2) Zirconia
- (3) Clogging

# DIAGNOSTIC TROUBLE CODE (DTC) DETECTING CRITERIA

## GENERAL DESCRIPTION

When abnormal, the variation period from rich to lean is longer than when normal, as shown in the figure below.

When the condition is completed, the variation time from rich to lean and vice versa is calculated by varying the desired A/F value. Judge NG when the period is long.

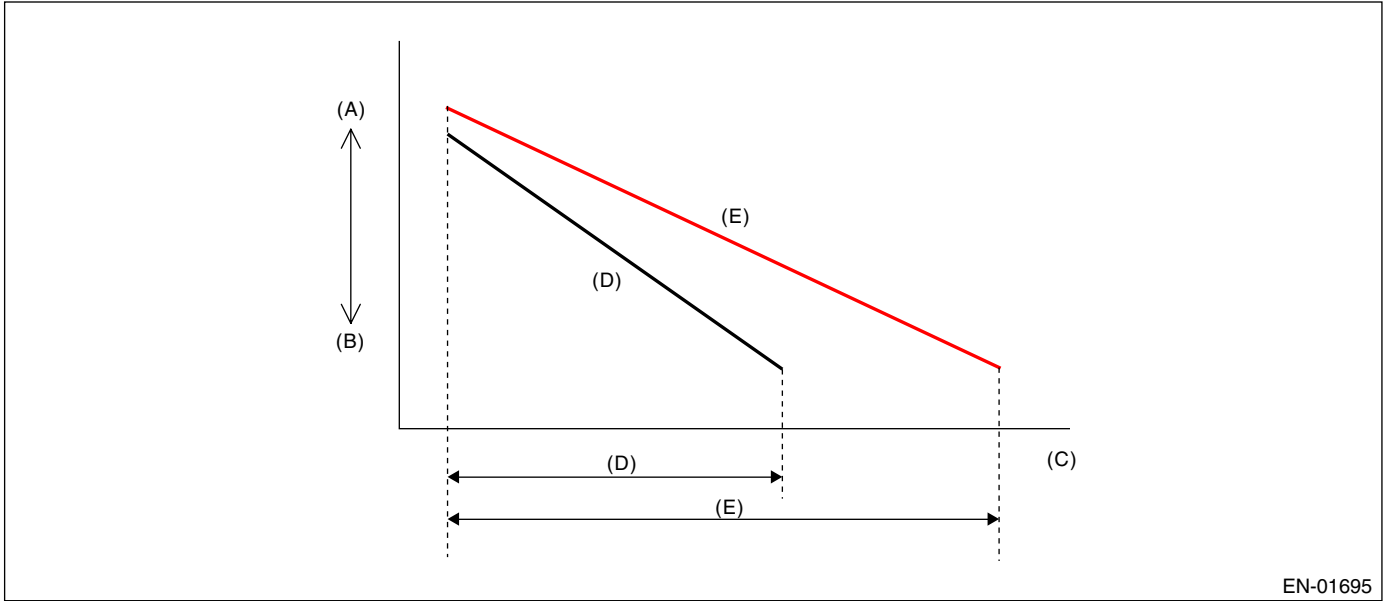

EN-01695

- |          |                 |
|----------|-----------------|
| (A) Rich | (D) Normal      |
| (B) Lean | (E) Malfunction |
| (C) Time |                 |

## 2. COMPONENT DESCRIPTION

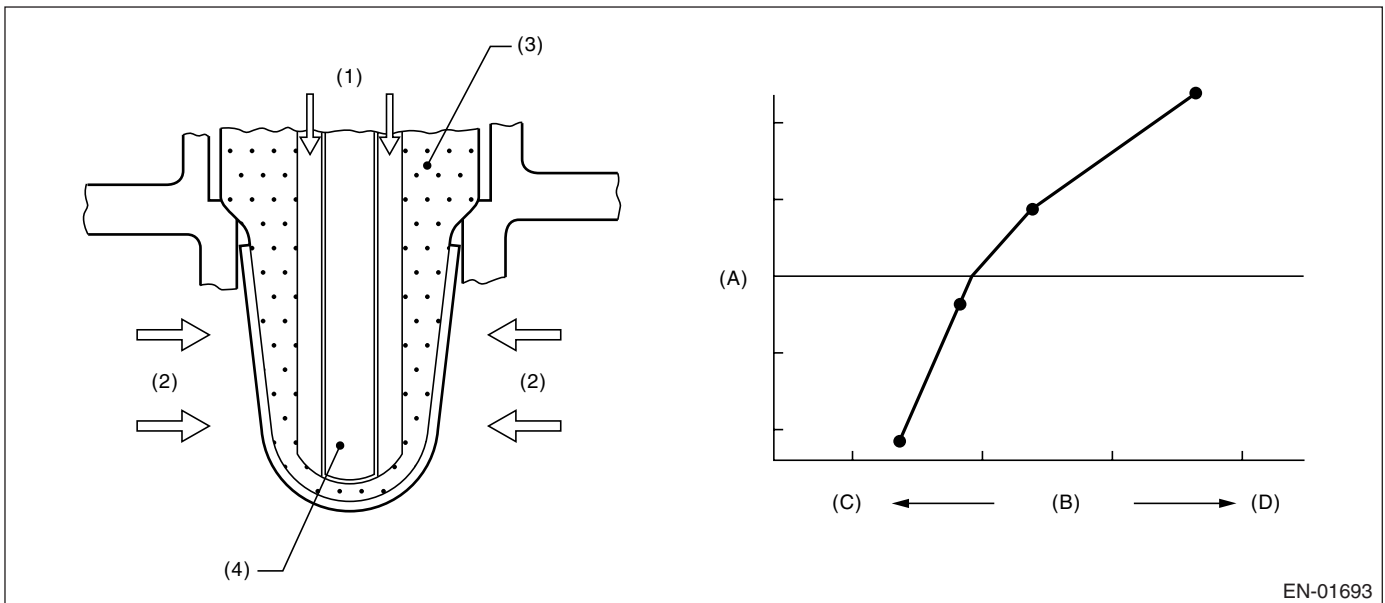

EN-01693

- |                      |                         |
|----------------------|-------------------------|
| (1) Atmosphere       | (A) Electromotive force |
| (2) Exhaust          | (B) Air fuel ratio      |
| (3) ZrO <sub>2</sub> | (C) Lean                |
| (4) Ceramic heater   | (D) Rich                |

# DIAGNOSTIC TROUBLE CODE (DTC) DETECTING CRITERIA

GENERAL DESCRIPTION

## 3. ENABLE CONDITION

Secondary Parameter	Enable Condition
Closed loop control	In operation
Average lambda	0.703 ←→ 1.375
After starting the engine	225 seconds or more
Engine coolant temperature	≥ 75°C (167°F)
Injector pulse	1.792 ←→ 4.032 milli-seconds
Engine speed	1800 ←→ 3000 rpm
Vehicle speed	≥ 76 km/h (47 MPH)
Atmospheric air pressure	≥ 76 kPa (568 mmHg, 22 inHg)
Throttle position change for 90 milliseconds	< 1.60°
Impedance of lambda sensor	10 ←→ 40 Ω
Misfire rate at engine 200 rev.	≤ 1.0%

## 4. GENERAL DRIVING CYCLE

Perform diagnosis constantly more than 76 km/h (47 MPH) just once in 225 seconds after starting the engine.

## 5. DIAGNOSTIC METHOD

When enable conditions are completed, measure the A/F sensor output A/F value variation period by changing air fuel ratio desired value to lean and rich. Judge NG when this period is long. Judge OK when this period is short.

Judge NG when the malfunction criteria below is completed. Judge OK when the malfunction criteria below is not completed.

### Judgment Value

Malfunction Criteria	Threshold Value
Average time of 5 changes from rich to lean, and from lean to rich	> See Map 5
Response time when noise is detected is not used as data.	

### Map 5

Engine Speed (Ne) (rpm)	1.75 ≤ TP < 2.25 (milliseconds)	2.25 ≤ TP < 2.75 (milliseconds)	2.75 ≤ TP < 3.19 (milliseconds)	3.19 ≤ TP (milliseconds)
≤ Ne <	1898	1731	1658	1591
≤ Ne < 2,500	1720	1570	1540	1530
2,500 ≤ Ne < 3,000	1674	1535	1499	1478
3,000 ≤ Ne	1674	1535	1499	1478

**Time Needed for Diagnosis:** 2 to 12 seconds

**Malfunction Indicator Light Illumination:** Illuminates when malfunction occurs in 2 continuous driving cycles.

## 6. DTC CLEAR CONDITION

- When the OK idling cycle was completed 40 times in a row
- When "Clear Memory" was performed

## 7. MALFUNCTION INDICATOR LIGHT CLEAR CONDITION

- When the OK driving cycle was completed 3 times in a row
- When "Clear Memory" was performed

# DIAGNOSTIC TROUBLE CODE (DTC) DETECTING CRITERIA

## GENERAL DESCRIPTION

---

### 8. FAIL SAFE

None

### 9. ECM OPERATION AT DTC SETTING

- Memorize the freeze frame data. (For test mode \$02)
- Memorize the diagnostic value and trouble standard value. (For test mode \$06)

# DIAGNOSTIC TROUBLE CODE (DTC) DETECTING CRITERIA

GENERAL DESCRIPTION

## AA: DTC P0134 — O<sub>2</sub> SENSOR CIRCUIT NO ACTIVITY DETECTED (BANK 1 SENSOR 1) —

### 1. OUTLINE OF DIAGNOSIS

Detect the open circuit of front oxygen (A/F) sensor.

Diagnosis is performed using A/F microcomputer, and communication is established between A/F microcomputer and main microcomputer. Judge NG when the data of open circuit NG is transmitted.

### 2. COMPONENT DESCRIPTION

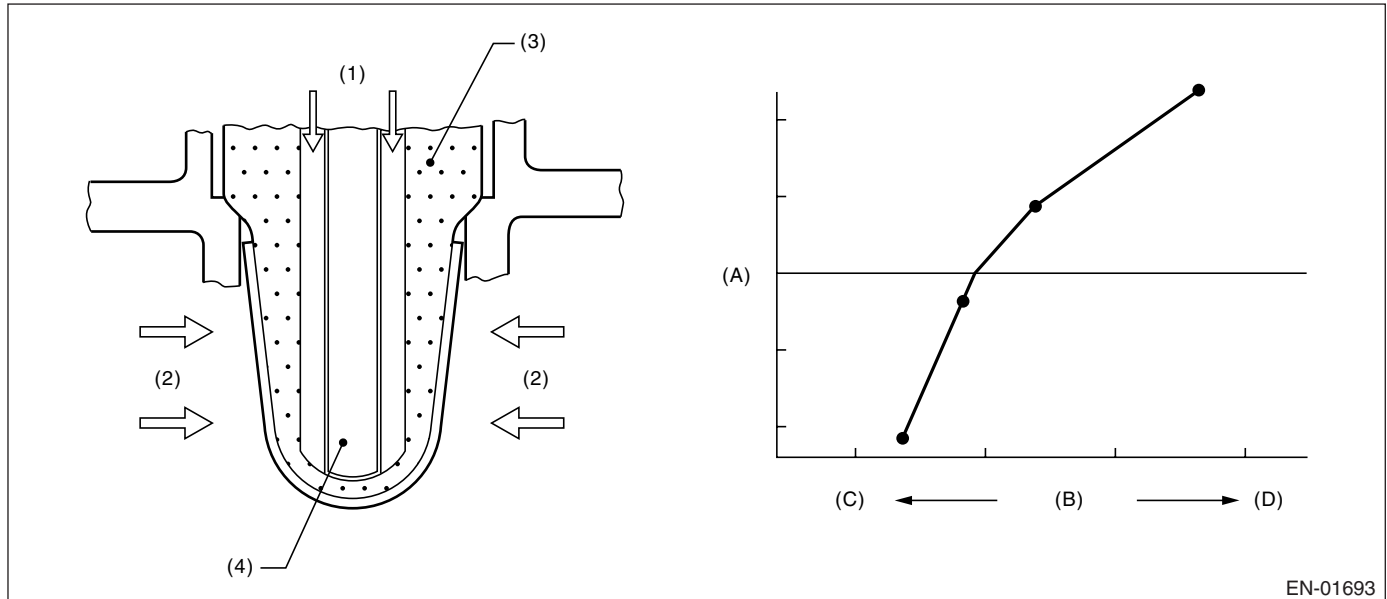

- (1) Atmosphere
- (2) Exhaust gas
- (3) ZrO<sub>2</sub>
- (4) Ceramic heater

- (A) Electromotive force
- (B) Air fuel ratio
- (C) Lean
- (D) Rich

### 3. ENABLE CONDITION

Secondary Parameters	Enable Conditions
None	

### 4. GENERAL DRIVING CYCLE

Terminate the diagnosis if the open circuit, low voltage short circuit or high voltage short circuit becomes NG once by performing diagnosis continuously.

### 5. DIAGNOSTIC METHOD

Judge NG when the continuous time of completing the malfunction criteria below becomes more than 5 seconds.

#### Judgment Value

Malfunction Criteria	Threshold Value
Heater control	In operation
Resistance of front oxygen (A/F) sensor	500 Ω

**Time Needed for diagnosis:** 5 seconds

**Malfunction Indicator Light Illumination:** Illuminates as soon as malfunction occurs.

# DIAGNOSTIC TROUBLE CODE (DTC) DETECTING CRITERIA

## GENERAL DESCRIPTION

---

### 6. DTC CLEAR CONDITION

- When the OK idling cycle was completed 40 times in a row
- When "Clear Memory" was performed

### 7. MALFUNCTION INDICATOR LIGHT CLEAR CONDITION

- When the OK driving cycle was completed 3 times in a row
- When "Clear Memory" was performed

### 8. FAIL SAFE

None

### 9. ECM OPERATION AT DTC SETTING

Memorize the freeze frame data. (For test mode \$02)



# DIAGNOSTIC TROUBLE CODE (DTC) DETECTING CRITERIA

GENERAL DESCRIPTION

## AB:DTC P0137 — O<sub>2</sub> SENSOR CIRCUIT LOW VOLTAGE (BANK 1 SENSOR 2) —

### 1. OUTLINE OF DIAGNOSIS

Detect the open or short circuit of rear oxygen sensor.  
Judge NG when out of the standard value.

### 2. COMPONENT DESCRIPTION

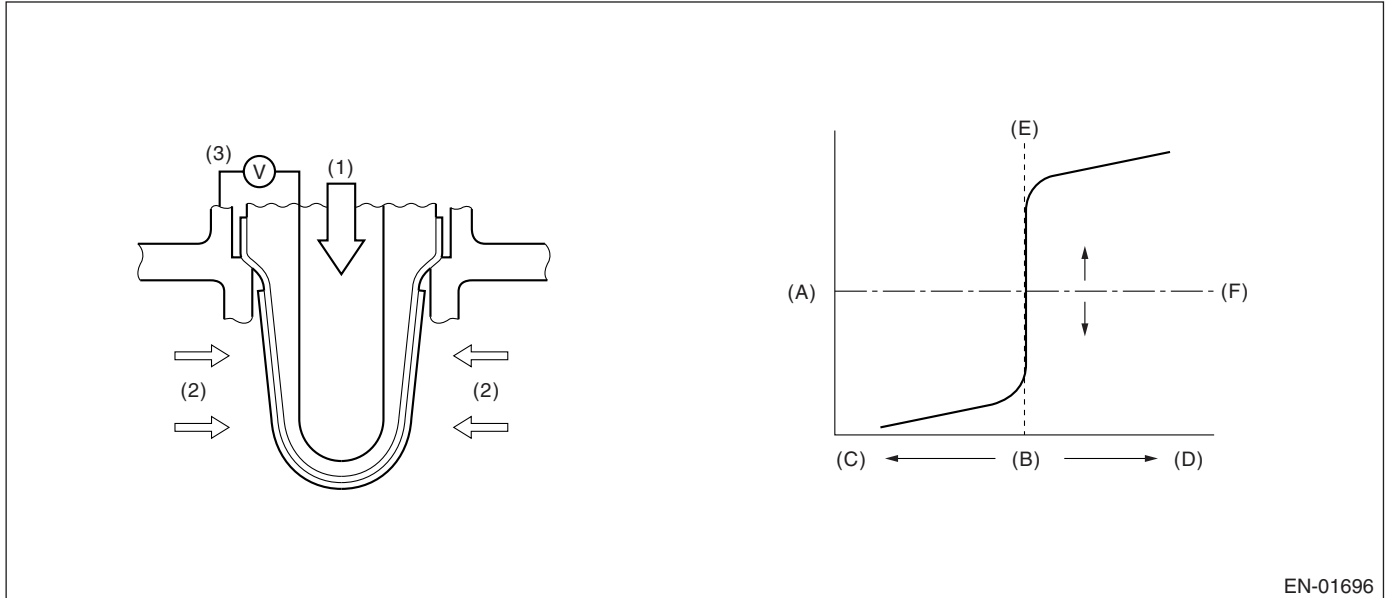

- (1) Atmosphere
- (2) Exhaust gas
- (3) Electromotive force

- (A) Electromotive force
- (B) Air fuel ratio
- (C) Lean
- (D) Rich
- (E) Theoretical air fuel ratio
- (F) Comparative voltage

### 3. ENABLE CONDITION

Secondary Parameters	Enable Conditions
Closed loop control	In operation

### 4. GENERAL DRIVING CYCLE

Perform the diagnosis only once during the closed loop.

# DIAGNOSTIC TROUBLE CODE (DTC) DETECTING CRITERIA

## GENERAL DESCRIPTION

---

### 5. DIAGNOSTIC METHOD

Judge NG when the cumulative time of completing the malfunction criteria below becomes more than time needed for diagnosis.

#### Judgment Value

Malfunction Criteria	Threshold Value
Maximum output voltage	< 490 mV
Engine coolant temperature	≥ 75°C (167°F)
Injector pulse	≥ 2.24 milliseconds
Engine speed	≥ 1500 rpm
2 seconds or more fuel shut-off in decel.	Experienced
Vehicle speed	≥ 32 km/h (20 MPH)
Engine misfire	None

**Time Needed for Diagnosis:** 200 seconds

**Malfunction Indicator Light Illumination:** Illuminates when malfunction occurs in 2 continuous driving cycles.

Judge OK and clear the NG when the malfunction criteria below are completed.

#### Judgment Value

Malfunction Criteria	Threshold Value
maximum output voltage	≥ 490 mV

### 6. DTC CLEAR CONDITION

- When the OK driving cycle was completed 40 times in a row
- When "Clear Memory" was performed

### 7. MALFUNCTION INDICATOR LIGHT CLEAR CONDITION

- When the OK driving cycle was completed 3 times in a row
- When "Clear Memory" was performed

### 8. FAIL SAFE

None

### 9. ECM OPERATION AT DTC SETTING

- Memorize the freeze frame data. (For test mode \$02)
- Memorize the diagnostic value and trouble standard value. (For test mode \$06)

# DIAGNOSTIC TROUBLE CODE (DTC) DETECTING CRITERIA

GENERAL DESCRIPTION

## AC:DTC P0138 — O<sub>2</sub> SENSOR CIRCUIT HIGH VOLTAGE (BANK 1 SENSOR 2) —

### 1. OUTLINE OF DIAGNOSIS

Detect the open or short circuit of rear oxygen sensor.  
Judge NG when out of the standard value.

### 2. COMPONENT DESCRIPTION

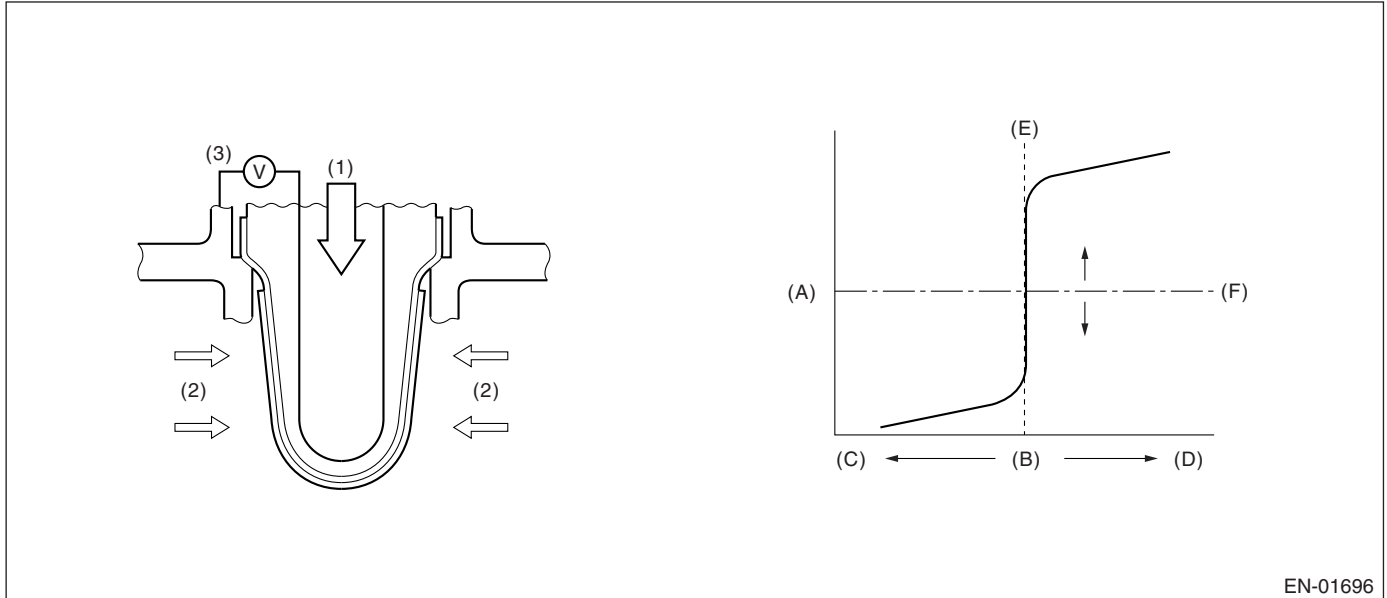

- (1) Atmosphere
- (2) Exhaust gas
- (3) Electromotive force

- (A) Electromotive force
- (B) Air fuel ratio
- (C) Lean
- (D) Rich
- (E) Theoretical air fuel ratio
- (F) Comparative voltage

### 3. ENABLE CONDITION

Secondary Parameters	Enable Conditions
Closed loop control	In operation

### 4. GENERAL DRIVING CYCLE

Perform the diagnosis only once during the closed loop.

# DIAGNOSTIC TROUBLE CODE (DTC) DETECTING CRITERIA

## GENERAL DESCRIPTION

---

### 5. DIAGNOSTIC METHOD

#### • Abnormality Judgment

Judge NG when the cumulative time of completing all the malfunction criteria below becomes more than time needed for diagnosis.

#### Judgment Value

Malfunction Criteria	Threshold Value
Minimum output voltage	> 250 mV
Engine coolant temperature	≥ 75°C (167°F)
Injector pulse	≥ 2.24 milliseconds
Engine speed	≥ 1500 rpm
2 seconds or more fuel shut-off in decel.	Experienced
Vehicle speed	≥ 32 km/h (20 MPH)
Engine misfire	No

**Time Needed for Diagnosis:** 200 seconds

**Malfunction Indicator Light Illumination:** Illuminates when malfunction occurs in 2 continuous driving cycles.

#### • Normality Judgment

Judge OK and clear the NG when the malfunction criteria below are completed.

#### Judgment Value

Malfunction Criteria	Threshold Value
Minimum output voltage	≤ 250 mV

### 6. DTC CLEAR CONDITION

- When the OK driving cycle was completed 40 times in a row
- When "Clear Memory" was performed

### 7. MALFUNCTION INDICATOR LIGHT CLEAR CONDITION

- When the OK driving cycle was completed 3 times in a row
- When "Clear Memory" was performed

### 8. FAIL SAFE

None

### 9. ECM OPERATION AT DTC SETTING

- Memorize the freeze frame data. (For test mode \$02)
- Memorize the diagnostic value and trouble standard value. (For test mode \$06)

## AD:DTC P0139 — O<sub>2</sub> SENSOR CIRCUIT SLOW RESPONSE (BANK 1 SENSOR 2)

### 1. OUTLINE OF DIAGNOSIS

Detect the slow response of rear oxygen sensor.

Calculate the response time of the output change of the rear oxygen sensor when the A/F ratio changes from rich to lean. And carry out the diagnosis comparing the calculated response time with the threshold value.

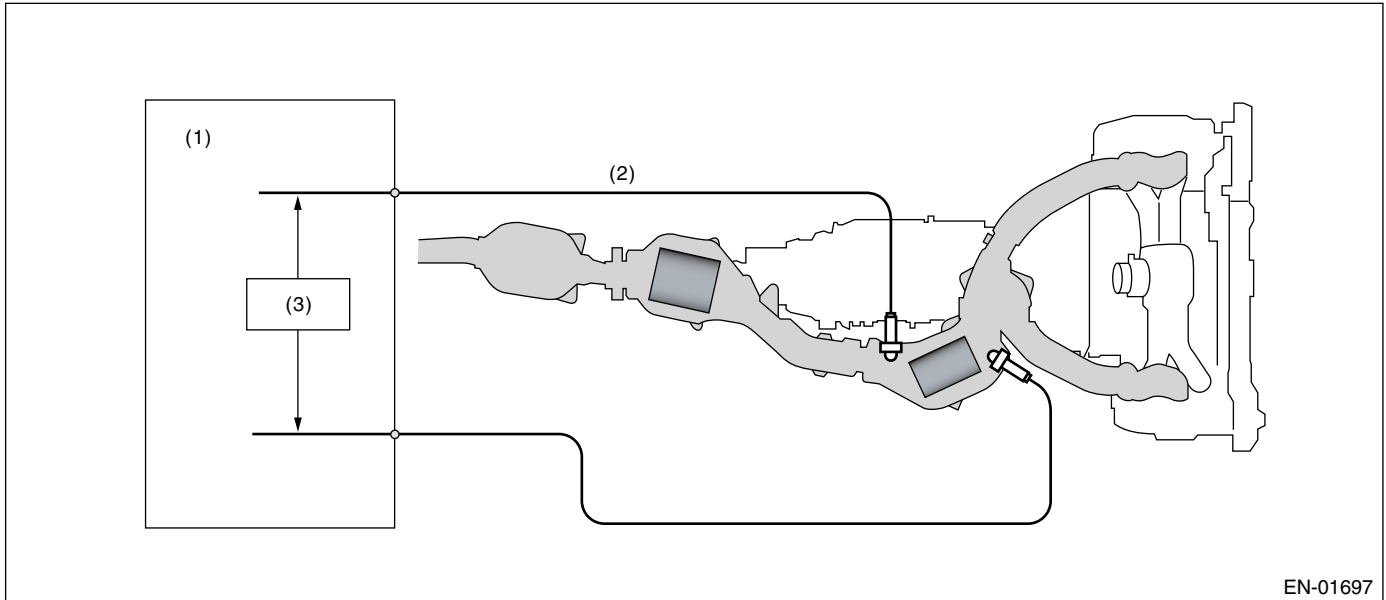

- (1) Engine control module (ECM)
- (2) Rear oxygen sensor
- (3) Diagnosis circuit

# DIAGNOSTIC TROUBLE CODE (DTC) DETECTING CRITERIA

## GENERAL DESCRIPTION

### 2. COMPONENT DESCRIPTION

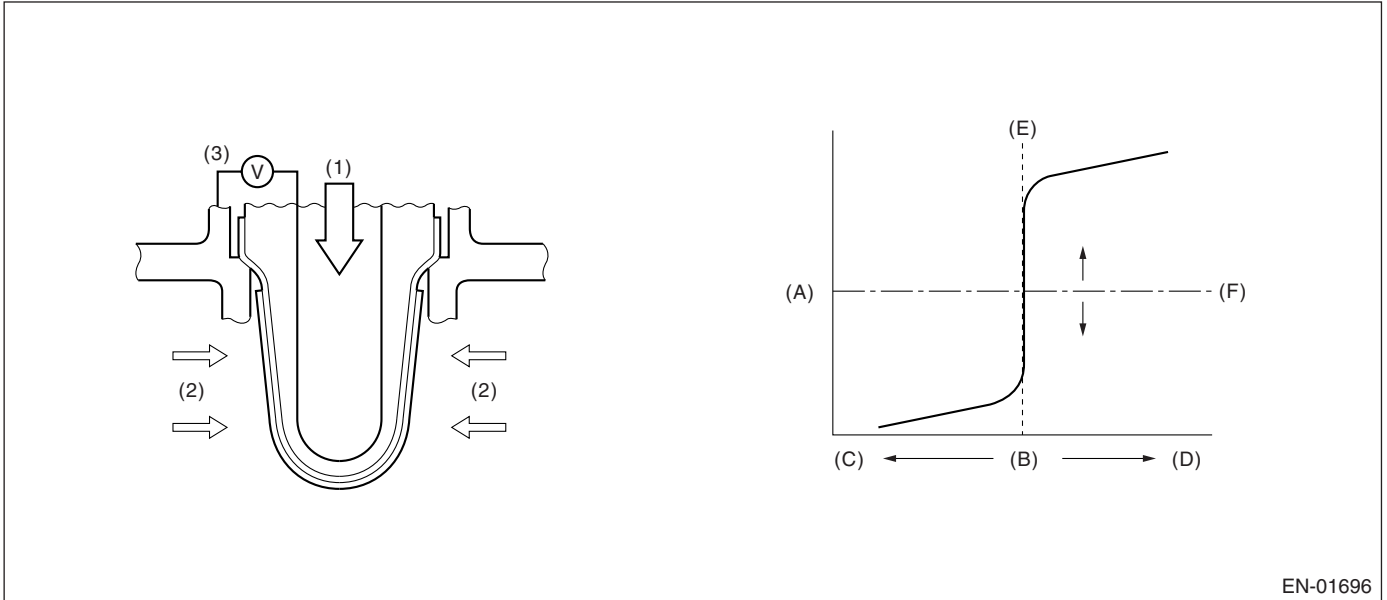

- (1) Atmosphere
- (2) Exhaust gas
- (3) Electromotive force

- (A) Electromotive force
- (B) Air fuel ratio
- (C) Lean
- (D) Rich
- (E) Theoretical air fuel ratio
- (F) Comparative voltage

### 3. ENABLE CONDITION

Secondary Parameters	Enable Conditions
Closed loop control with rear oxygen sensor	In operation

### 4. GENERAL DRIVING CYCLE

Diagnosis is performed only once when the deceleration fuel is cut from the rapid acceleration. (Pay attention to oxygen sensor voltage to calculate the diagnostic value when deciding the deceleration timing.)

# DIAGNOSTIC TROUBLE CODE (DTC) DETECTING CRITERIA

GENERAL DESCRIPTION

## 5. DIAGNOSTIC METHOD

When the rear oxygen sensor output voltage changes from 0.5 V (rich) to 0.15 V (lean), carry out calculation regarding the response time of the output change from 0.45 V to 0.2 V as diagnostic value. When the rear oxygen sensor output voltage does not change from 0.5 V to 0.15 V, do not carry out calculation even if the output changes from 0.45 V to 0.2 V.

### • Abnormality Judgment

Judge NG when the rear oxygen sensor output change response time (diagnostic value) exceeds the threshold value.

Response time > 2 seconds (threshold value) → Abnormal

Judge NG when all of the malfunction criteria below is completed.

### Judgment Value

Malfunction Criteria	Threshold Value
Shortest time change from rich (450 mV oxygen output) to lean (200 mV) if voltage reduces from 500 mV to 150 mV	≥ 0.43 seconds
2 seconds or more fuel shut-off in decel. After fuel shut-off	Experienced 2 seconds or more

**Time Needed for Diagnosis:** 4 seconds

**Malfunction Indicator Light Illumination:** Illuminates when malfunction occurs in 2 continuous driving cycles.

### • Normality Judgment

Judge OK when the rear oxygen sensor output change response time (diagnostic value) is below the threshold value.

Response time ≤ 2 seconds (threshold value) → Normal

Judge NG when the malfunction criteria below is completed.

### Judgment Value

Malfunction Criteria	Threshold Value
Shortest time change	≤ 0.43 seconds

# DIAGNOSTIC TROUBLE CODE (DTC) DETECTING CRITERIA

## GENERAL DESCRIPTION

### NOTE:

Response time is calculated during the deceleration fuel cut in case of abnormal judgment. However, in order to make a normal judgment quickly, diagnosis is performed without deceleration fuel cut.

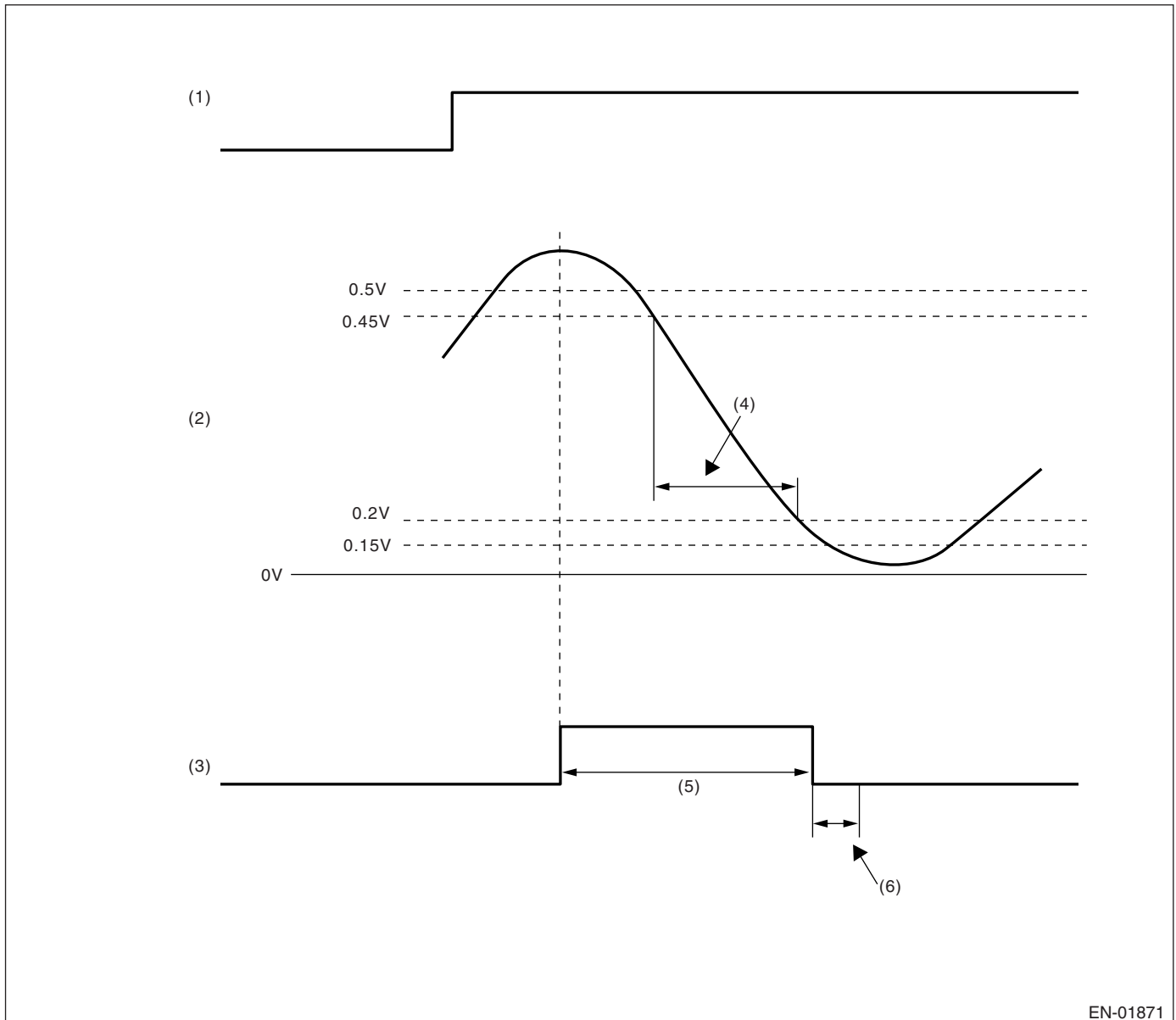

- (1) Diagnosis execution condition
- (2) Rear oxygen sensor (V)
- (3) Fuel cut on deceleration

- (4) Measure the response time.
- (5) More than 2 seconds
- (6) Execute the malfunction judgment in 2 seconds from the recovery of fuel cut on deceleration.

## 6. DTC CLEAR CONDITION

- When the OK idling cycle was completed 40 times in a row
- When "Clear Memory" was performed

## 7. MALFUNCTION INDICATOR LIGHT CLEAR CONDITION

- When the OK driving cycle was completed 3 times in a row
- When "Clear Memory" was performed



# DIAGNOSTIC TROUBLE CODE (DTC) DETECTING CRITERIA

GENERAL DESCRIPTION

---

## 8. FAIL SAFE

None

## 9. ECM OPERATION AT DTC SETTING

- Memorize the freeze frame data. (For test mode \$02)
- Memorize the diagnostic value and trouble standard value. (For test mode \$06)

# DIAGNOSTIC TROUBLE CODE (DTC) DETECTING CRITERIA

## GENERAL DESCRIPTION

### AE:DTC P0171 — SYSTEM TOO LEAN (BANK 1) —

#### 1. OUTLINE OF DIAGNOSIS

Detect the malfunction of fuel system by the amount of main feedback control.

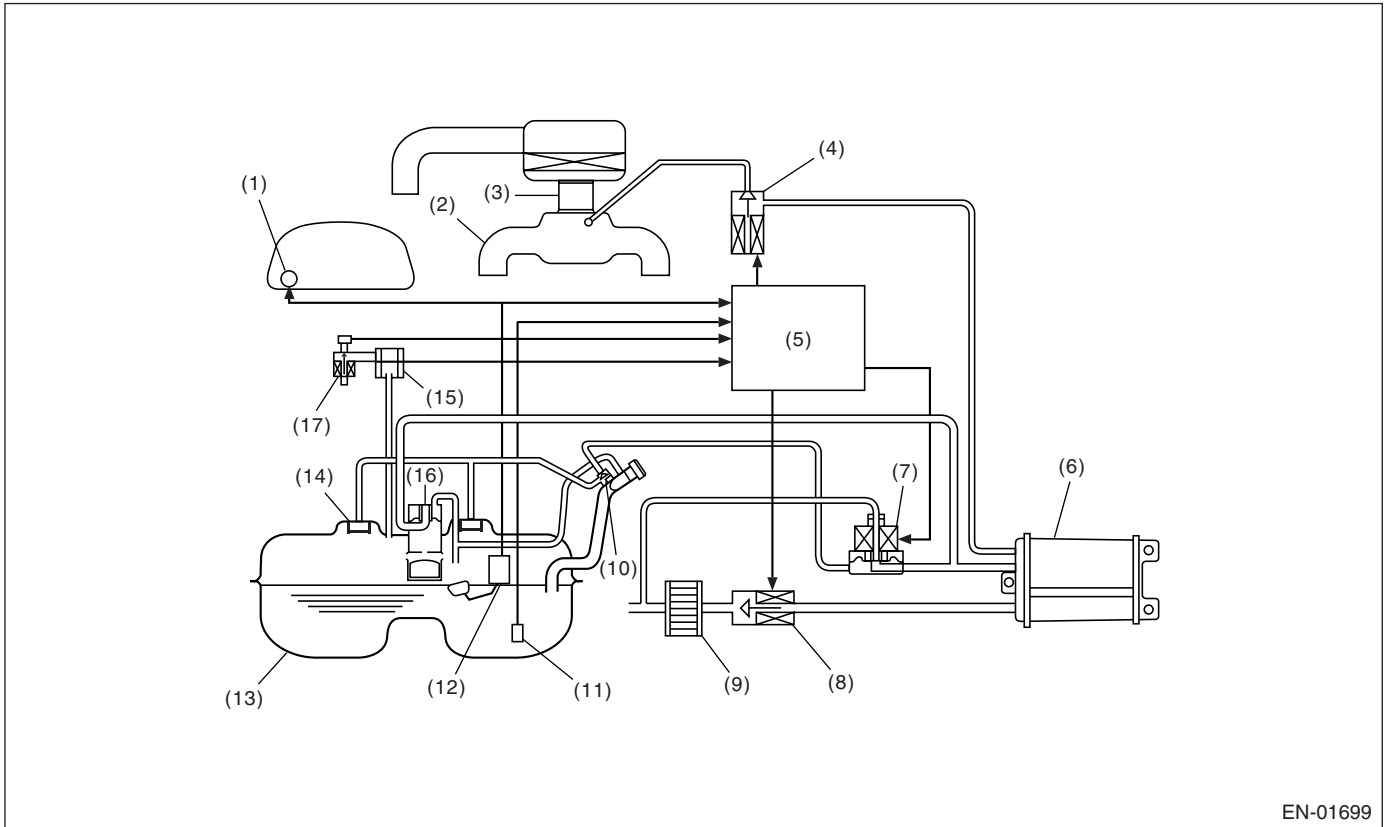

EN-01699

- |                                     |                                             |
|-------------------------------------|---------------------------------------------|
| (1) Fuel meter                      | (10) Shut-off valve                         |
| (2) Intake manifold                 | (11) Fuel temperature sensor                |
| (3) Throttle body                   | (12) Fuel level sensor                      |
| (4) Purge control solenoid valve    | (13) Fuel tank                              |
| (5) Engine control module (ECM)     | (14) Fuel cut valve                         |
| (6) Canister                        | (15) Fuel tank pressure sensor              |
| (7) Pressure control solenoid valve | (16) Vent valve                             |
| (8) Drain valve                     | (17) Tank pressure switching solenoid valve |
| (9) Drain filter                    |                                             |

Fuel system is diagnosed by comparing the target air fuel ratio calculated by ECM with the actual air fuel ratio measured by sensor.

# DIAGNOSTIC TROUBLE CODE (DTC) DETECTING CRITERIA

GENERAL DESCRIPTION

## 2. ENABLE CONDITION

Secondary Parameters	Enable Conditions
Fuel learning system	In operation
Engine coolant temperature	75 ↔ 110°C (167 ↔ 230°F)
Intake manifold pressure change during 50 msec	≤ 1.9 kPa (14.6 mmHg, 0.6 inHg)
Learning value of EVAP conc. during purge	≤ 1.0
Cumulative time of canister purge after engine start	20 seconds or more
Continuous period after canister purge starting	10 seconds or more
Intake air temperature	≥ Map 3

### Map 3

Engine speed (rpm)	Idle	800	1200	1600	2000	2400	2800	3200	3600	4000	4400
Pressure kPa (mmHg, inHg)	ha	24.0 (180, 7.1)	27.2 (204, 8.0)	27.2 (204, 8.0)	28.3 (212, 8.3)	29.9 (224, 8.8)	32.5 (244, 9.6)	34.1 (256, 10.1)	34.1 (256, 10.1)	33.1 (248, 9.8)	33.1 (248, 9.8)

## 3. GENERAL DRIVING CYCLE

Perform the serial diagnoses at idling after engine warmed up or with a constant vehicle speed.

## 4. DIAGNOSTIC METHOD

Judge that the malfunction occurred in fuel system when the malfunction criteria are completed for 50 seconds or more by comparing the diagnostic value (fsobd) with threshold value.

### Judgment Value

Malfunction Criteria	Threshold Value
fsobd = aflmd + lambda + kblrc	≥ fsobdL1
aflmd = measured lambda lambda = short term fuel trim kblrc = long term fuel trim	See Map 2 fsobdL1 = lean side threshold value of fsobd

### Map 2: Threshold value for fuel system malfunction criteria

Amount of air (g/s)	0	3.2	6.4	9.6	12.8	16	19.2
fsobdL1 (%)	40	40	33.2	26.5	26.5	26.5	26.5

**Time Needed for Diagnosis:** 10 seconds × 5 times

**Malfunction Indicator Light Illumination:** Twice continuous driving cycles.

Judge OK when the malfunction criteria below are completed for 10 seconds or more.

### Judgment Value

Malfunction Criteria	Threshold Value
fsobd = aflmd + lambda + kblrc	< 19%

## 5. DTC CLEAR CONDITION

- When the OK idling cycle is completed 40 times in a row
- When "Clear Memory" was performed

## 6. MALFUNCTION INDICATOR LIGHT CLEAR CONDITION

- When diagnosed OK with the similar driving for 3 driving cycles in a row
- When "Clear Memory" was performed

## 7. FAIL SAFE

None

# DIAGNOSTIC TROUBLE CODE (DTC) DETECTING CRITERIA

## GENERAL DESCRIPTION

---

### 8. ECM OPERATION AT DTC SETTING

Memorize the freeze frame data. (For test mode \$02)

# DIAGNOSTIC TROUBLE CODE (DTC) DETECTING CRITERIA

GENERAL DESCRIPTION

## AF:DTC P0172 — SYSTEM TOO RICH (BANK 1) —

### 1. OUTLINE OF DIAGNOSIS

Detect the malfunction of fuel system by the amount of main feedback control.

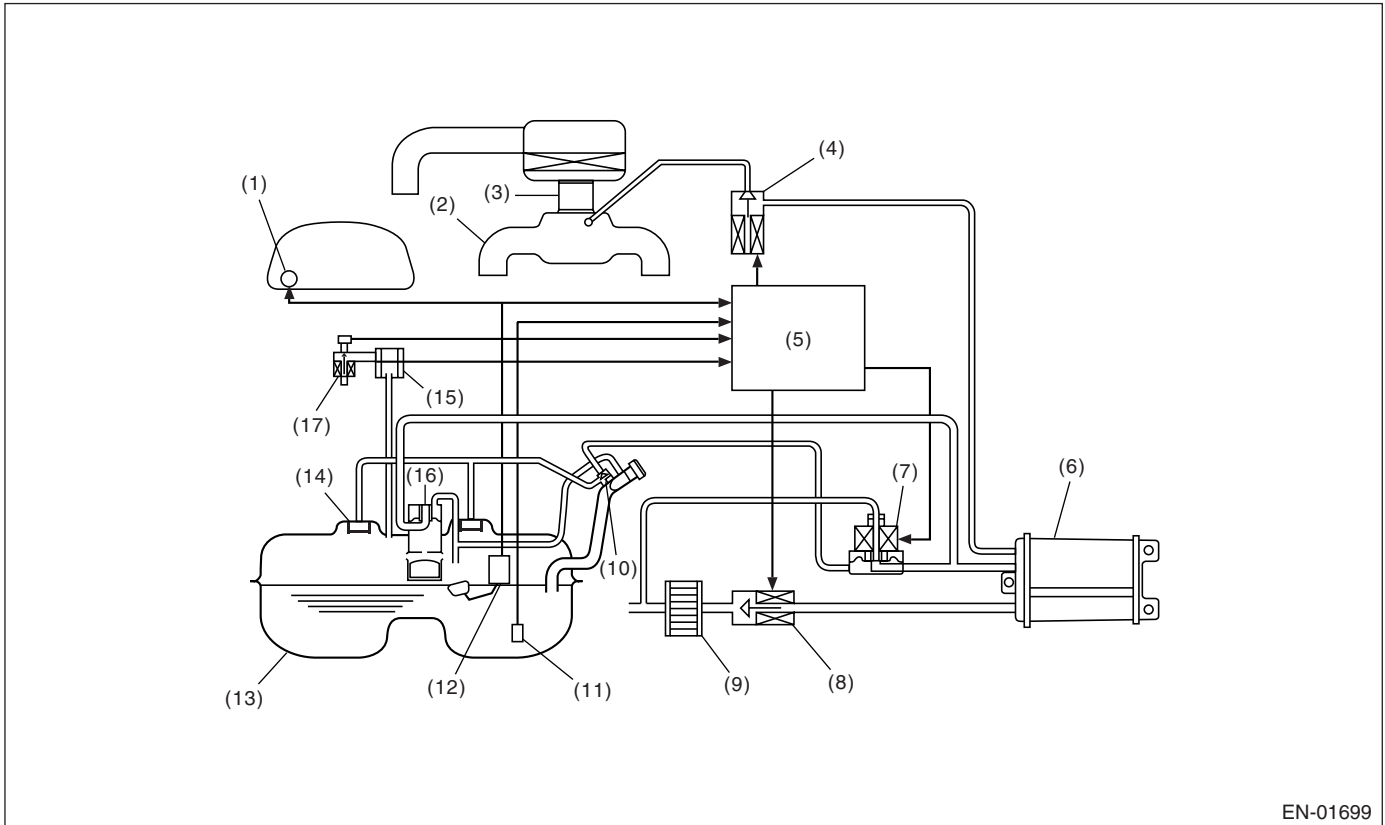

- |                                     |                                             |
|-------------------------------------|---------------------------------------------|
| (1) Fuel meter                      | (10) Shut-off valve                         |
| (2) Intake manifold                 | (11) Fuel temperature sensor                |
| (3) Throttle body                   | (12) Fuel level sensor                      |
| (4) Purge control solenoid valve    | (13) Fuel tank                              |
| (5) Engine control module (ECM)     | (14) Fuel cut valve                         |
| (6) Canister                        | (15) Fuel tank pressure sensor              |
| (7) Pressure control solenoid valve | (16) Vent valve                             |
| (8) Drain valve                     | (17) Tank pressure switching solenoid valve |
| (9) Drain filter                    |                                             |

Fuel system is diagnosed by comparing the target air fuel ratio calculated by ECM with the actual air fuel ratio measured by sensor.

# DIAGNOSTIC TROUBLE CODE (DTC) DETECTING CRITERIA

## GENERAL DESCRIPTION

### 2. ENABLE CONDITION

Secondary Parameters	Enable Conditions
Fuel learning system	In operation
Engine coolant temperature	75 ↔ 110°C (167 ↔ 230°F)
Intake manifold pressure change during 50 msec	≤ 1.9 kPa (14.6 mmHg, 0.6 inHg)
Learning value of EVAP conc. during purge	≤ 1.0
Cumulative time of canister purge after engine start	20 seconds or more
Continuous period after canister purge starting	10 seconds or more
Intake air temperature	≥ Map 3

#### Map 3

Engine speed (rpm)	Idle	800	1200	1600	2000	2400	2800	3200	3600	4000	4400
Pressure kPa (mmHg, inHg)	ha	24.0 (180, 7.1)	27.2 (204, 8.0)	27.2 (204, 8.0)	28.3 (212, 8.3)	29.9 (224, 8.8)	32.5 (244, 9.6)	34.1 (256, 10.1)	34.1 (256, 10.1)	33.1 (248, 9.8)	33.1 (248, 9.8)

### 3. GENERAL DRIVING CYCLE

Perform the serial diagnoses.

### 4. DIAGNOSTIC METHOD

Judge that the malfunction occurred in fuel system when the malfunction criteria are completed for 50 seconds or more by comparing the diagnostic value (fsobd) with threshold value.

#### Judgment Value

Malfunction Criteria	Threshold Value
fsobd = aflmd + lambda + kblrc	≤ fsobdR1
aflmd = measured lambda lambda = short term fuel trim kblrc = long term fuel trim	See Map 2 fsobdR1 = rich side threshold value of fsobd

#### Map 2: Threshold value for fuel system malfunction criteria

Amount of air (g/s)	0	3.2	6.4	9.6	12.8	16	19.2
fsobdR1 (%)	-45	-45	-36	-26.5	-26.5	-26.5	26.5

**Time Needed for Diagnosis:** 10 seconds × 5 times

**Malfunction Indicator Light Illumination:** Twice continuous driving cycles.

Judge OK when the malfunction criteria below are completed for 10 seconds or more.

#### Judgment Value

Malfunction Criteria	Threshold Value
fsobd = aflmd + lambda + kblrc	≥ -20%

### 5. DTC CLEAR CONDITION

- When the OK idling cycle is completed 40 times in a row
- When "Clear Memory" was performed

### 6. MALFUNCTION INDICATOR LIGHT CLEAR CONDITION

- When diagnosed OK with the similar driving for 3 driving cycles in a row
- When "Clear Memory" was performed

### 7. FAIL SAFE

None

# DIAGNOSTIC TROUBLE CODE (DTC) DETECTING CRITERIA

GENERAL DESCRIPTION

---

## 8. ECM OPERATION AT DTC SETTING

Memorize the freeze frame data. (For test mode \$02)

# DIAGNOSTIC TROUBLE CODE (DTC) DETECTING CRITERIA

## GENERAL DESCRIPTION

### AG:DTC P0181 — FUEL TEMPERATURE SENSOR “A” CIRCUIT RANGE/PERFORMANCE —

#### 1. OUTLINE OF DIAGNOSIS

Detect the malfunction of fuel temperature sensor output property.  
Diagnosis is performed in two methods; namely, drift diagnosis and stuck diagnosis.

#### 2. COMPONENT DESCRIPTION

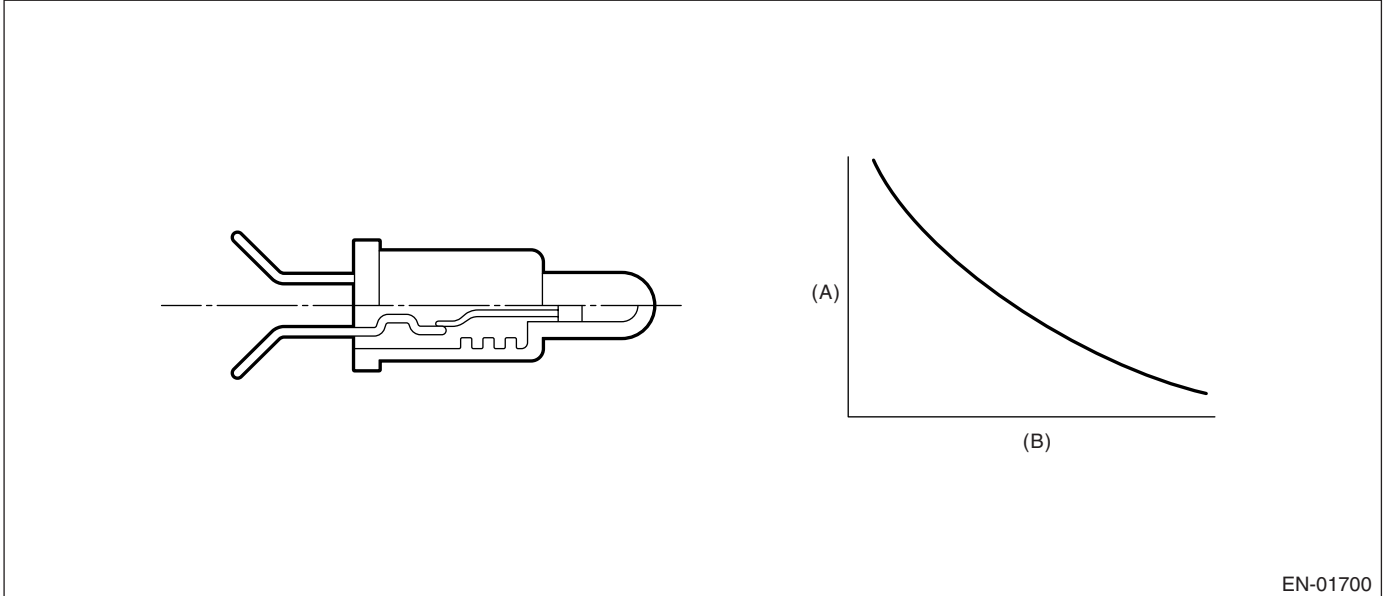

- (A) Resistance value ( $\Omega$ )
- (B) Fuel temperature  $^{\circ}\text{C}$  ( $^{\circ}\text{F}$ )

#### • Drift Diagnosis

Normally fuel temperature is lower than engine coolant temperature. When the fuel temperature becomes higher than the engine coolant temperature, the range is considered to be shifted, and NG judgment is done.

#### 3. ENABLE CONDITION

Secondary Parameters	Enable Conditions
Fuel level	$\geq 10 \text{ l}$ (2.6 US gal, 2.2 Imp gal)
After engine starting	20 seconds or more
Engine coolant temperature difference from engine start	$> -10^{\circ}\text{C}$ ( $18^{\circ}\text{F}$ )

#### 4. GENERAL DRIVING CYCLE

Perform the diagnosis continuously when the engine coolant temperature increases more than  $-10$  degrees ( $18$  degrees of Fahrenheit) from the temperature of engine starting in 20 seconds after starting the engine.



# DIAGNOSTIC TROUBLE CODE (DTC) DETECTING CRITERIA

GENERAL DESCRIPTION

## 5. DIAGNOSTIC METHOD

Judge NG when the continuous time until completing the malfunction criteria below becomes more than the time (120 seconds) needed for diagnosis. Also, judge OK when the malfunction criteria below is not completed. And then, clear the NG.

### Judgment Value

Malfunction Criteria	Threshold Value
Fuel temperature-engine coolant temperature	$\geq 10^{\circ}\text{C}$ (18°F)

**Time Needed for Diagnosis:** 120 seconds

**Malfunction Indicator Light Illumination:** Illuminates when malfunction occurs in 2 continuous driving cycles.

### • Stuck Diagnosis

If the fuel temperature which must increase along with engine idling does not increase, the engine is considered to be stuck and NG judgment is done.

## 6. ENABLE CONDITION

Secondary Parameters	Enable Conditions
After engine starting	20 seconds or more

## 7. GENERAL DRIVING CYCLE

Perform the diagnosis continuously in 20 seconds and more after starting the engine.

## 8. DIAGNOSTIC METHOD

### • Abnormality Judgment

Judge NG when all of the malfunction criteria below is completed.

Malfunction Criteria	Threshold Value
Accumulated amount of intake air	$\geq 550$ kg (1213 lb)
Fuel temperature difference between max and min	$< 3^{\circ}\text{C}$ (5.4°F)

### • Normality Judgment

Judge OK and clear the NG when the malfunction criteria below are completed.

Malfunction Criteria	Threshold Value
Fuel temperature difference between max. and min.	$\geq 3^{\circ}\text{C}$ (5.4°F)

**Time Needed for Diagnosis:** Undecided

**Malfunction Indicator Light Illumination:** Illuminates when malfunction occurs in 2 continuous driving cycles.

## 9. DTC CLEAR CONDITION

- When the OK idling was completed 40 times in a row
- When "Clear Memory" was performed

## 10.MALFUNCTION INDICATOR LIGHT CLEAR CONDITION

- When the OK driving cycle was completed 3 times in a row
- When "Clear Memory" was performed

## 11.FAIL SAFE

Fix the fuel temperature at  $40^{\circ}\text{C}$  (104°F).

## 12.ECM OPERATION AT DTC SETTING

Memorize the freeze frame data. (For test mode \$02)

# DIAGNOSTIC TROUBLE CODE (DTC) DETECTING CRITERIA

## GENERAL DESCRIPTION

### AH:DTC P0182 — FUEL TEMPERATURE SENSOR “A” CIRCUIT LOW INPUT —

#### 1. OUTLINE OF DIAGNOSIS

Detect the open or short circuit of fuel temperature sensor.  
Judge NG when out of the standard value.

#### 2. COMPONENT DESCRIPTION

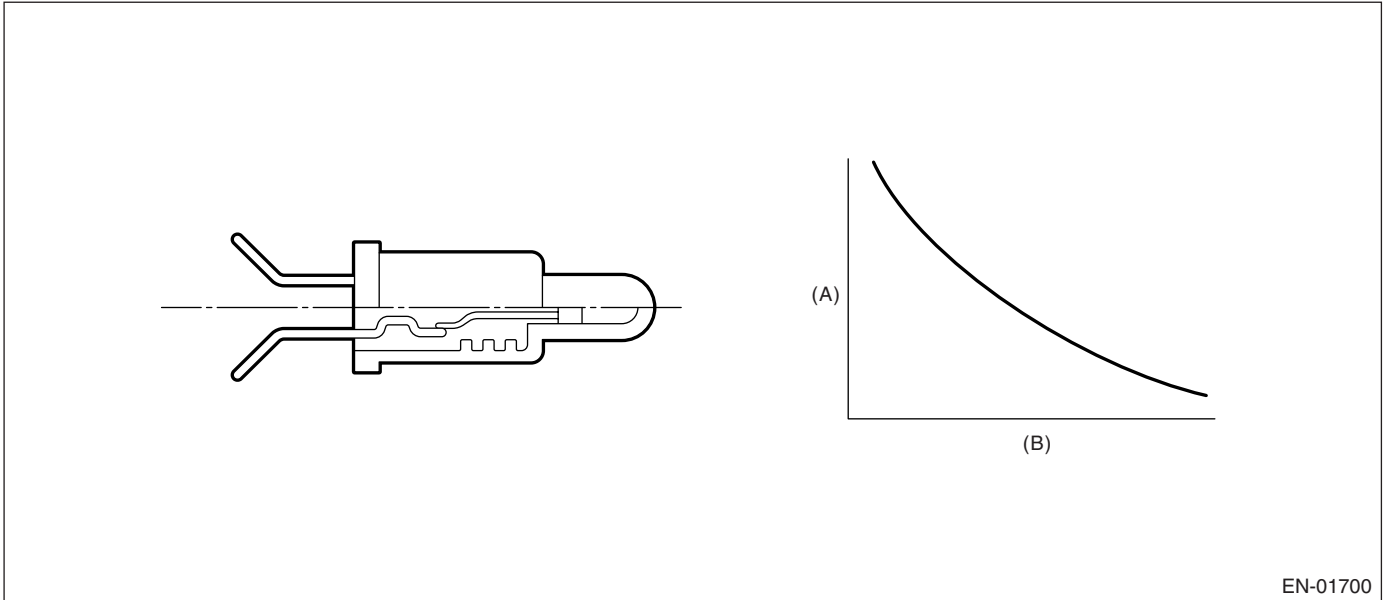

(A) Resistance value ( $\Omega$ )

(B) Fuel temperature  $^{\circ}\text{C}$  ( $^{\circ}\text{F}$ )

#### 3. ENABLE CONDITION

Secondary Parameters	Enable Conditions
None	

#### 4. GENERAL DRIVING CYCLE

Always perform the diagnosis continuously after starting the engine.

#### 5. DIAGNOSTIC METHOD

Judge NG when the continuous time of completing the malfunction criteria below becomes more than the time (2.5 seconds) needed for diagnosis. Judge OK and clear NG when the malfunction criteria below are not completed.

##### Judgment Value

Malfunction Criteria	Threshold Value
Output voltage	$\leq 0.1 \text{ V}$

**Time Needed for Diagnosis:** 2.5 seconds

**Malfunction Indicator Light Illumination:** Illuminates as soon as malfunction occurs.

#### 6. DTC CLEAR CONDITION

- When the OK idling cycle was completed 40 times in a row
- When “Clear Memory” was performed

#### 7. MALFUNCTION INDICATOR LIGHT CLEAR CONDITION

- When the OK driving cycle was completed 3 times in a row
- When “Clear Memory” was performed

# DIAGNOSTIC TROUBLE CODE (DTC) DETECTING CRITERIA

GENERAL DESCRIPTION

---

## 8. FAIL SAFE

Fix the fuel temperature for control at 40°C (104°F).

## 9. ECM OPERATION AT DTC SETTING

Memorize the freeze frame data. (For test mode \$02)

# DIAGNOSTIC TROUBLE CODE (DTC) DETECTING CRITERIA

## GENERAL DESCRIPTION

### AI: DTC P0183 — FUEL TEMPERATURE SENSOR “A” CIRCUIT HIGH INPUT —

#### 1. OUTLINE OF DIAGNOSIS

Detect the open or short circuit of fuel temperature sensor.  
Judge NG when out of the standard value.

#### 2. COMPONENT DESCRIPTION

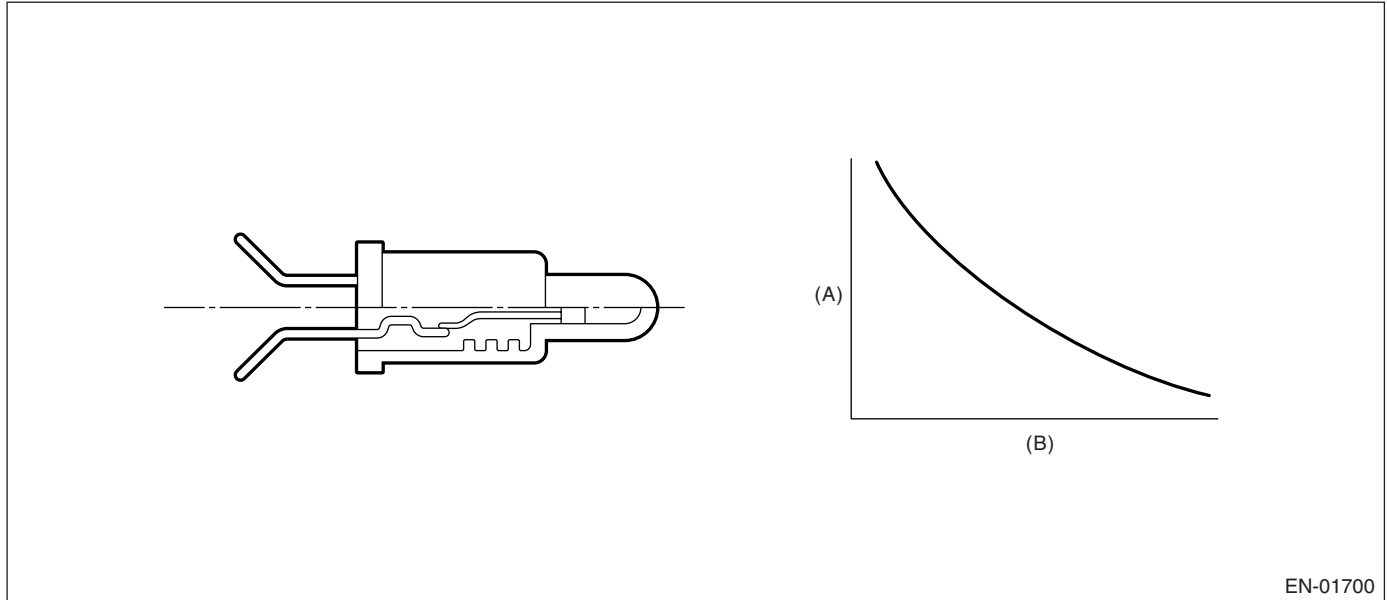

(A) Resistance value (Ω)

(B) Fuel temperature °C (°F)

EN-01700

#### 3. ENABLE CONDITION

Secondary Parameters	Enable Conditions
None	

#### 4. GENERAL DRIVING CYCLE

Always perform the diagnosis continuously after starting the engine.

#### 5. DIAGNOSTIC METHOD

Judge NG when the cumulative time of completing the malfunction criteria below becomes more than time (2.5 seconds) needed for diagnosis. Judge OK when the malfunction criteria below are not completed.

##### Judgment Value

Malfunction Criteria	Threshold Value
Output voltage	≥ 4.85 V

**Time Needed for Diagnosis:** 2.5 seconds

**Malfunction Indicator Light Illumination:** Illuminates as soon as malfunction occurs.

#### 6. DTC CLEAR CONDITION

- When the OK idling cycle was completed 40 times in a row
- When “Clear Memory” was performed

#### 7. MALFUNCTION INDICATOR LIGHT CLEAR CONDITION

- When the OK driving cycle was completed 3 times in a row
- When “Clear Memory” was performed

# DIAGNOSTIC TROUBLE CODE (DTC) DETECTING CRITERIA

GENERAL DESCRIPTION

---

## 8. FAIL SAFE

Fix the fuel temperature for control at 40°C (104°F).

## 9. ECM OPERATION AT DTC SETTING

Memorize the freeze frame data. (For test mode \$02)

# DIAGNOSTIC TROUBLE CODE (DTC) DETECTING CRITERIA

## GENERAL DESCRIPTION

### AJ:DTC P0301 — CYLINDER 1 MISFIRE DETECTED —

#### 1. OUTLINE OF DIAGNOSIS

Detect the presence of misfire occurrence.

Monitoring Misfire which influences exhaust deterioration (1.5 times of FTP) and catalyst damage is made obligatory by the law. Misfire affecting these two has three patterns below.

- Intermittent misfire (Different cylinders misfire intermittently.): FTP 1.5 times misfire
- Every time misfire (The same cylinder misfires every time.): Catalyst damage misfire, FTP 1.5 times misfire
- Opposed misfire (Dual ignition equipped model as #1, #2 simultaneously ignite. NA model only.): Catalyst damage misfire, FTP 1.5 times misfire

The following detecting methods are adopted for these detection.

- (1) Intermittent misfire: FTP 1.5 times misfire
  - 180° Interval Difference Method (3,550 rpm or less)
  - 720° Interval Difference Method (2,950 rpm or less)
- (2) Every time misfire: Catalyst damage misfire, FTP 1.5 times misfire
  - 180° Interval Difference Method (3,550 rpm or less)
  - Pattern Recognition Method (2,950 rpm or more)
- (3) Opposed misfire: Catalyst damage misfire, FTP 1.5 times misfire
  - 180° Interval Difference Method (3,550 rpm or less)
  - Pattern Recognition Method (2,950 rpm or more)

#### 2. ENABLE CONDITION

Secondary Parameters	Enable Conditions
Injector pulse	≥ 1.00 milliseconds
Engine speed	450 — 6200 rpm
Fuel shut-off function	Not operating
Fuel parameter determination	Not as extremely low volatility
Engine speed change	≥ Misfire level × -4.00
After fuel shut-off finished	15 revs. or more
(Weighted avg. value / given amount) of intake air -1.0	-0.5 ←→ 1.9
Fuel level	≥ 9 ℓ (2.4 US gal, 2.0 Imp gal)
Crankshaft position learning	Completed
Intake manifold pressure	> Value from Map 4
The change in torque during shifting	Not in operation
Throttle position change during 30 milliseconds	-20° ←→ 20°
Engine speed (Misfire detection by oxygen sensor)	> 4600 rpm

#### Map 4

rpm	0	400	800	1200	1600	2000	2400	2800
MT (V. Speed < 64 km/h (40 MPH)) kPa (mmHg, inHg)	21.9 (164, 6.5)	21.9 (164, 6.5)	21.9 (164, 6.5)	19.2 (144, 5.7)	18.7 (140, 5.5)	19.2 (144, 5.7)	18.7 (140, 5.5)	19.7 (148, 5.8)
(V. Speed ≥ 64 km/h (40 MPH)) kPa (mmHg, inHg)	21.9 (164, 6.5)	21.9 (164, 6.5)	21.9 (164, 6.5)	25.6 (192, 7.6)	25.1 (188, 7.4)	25.6 (192, 7.6)	24.5 (184, 7.2)	31.5 (236, 9.3)
AT kPa (mmHg, inHg)	22.9 (172, 6.8)	22.9 (172, 6.8)	22.9 (172, 6.8)	20.3 (152, 6.0)	20.3 (152, 6.0)	21.3 (160, 6.3)	20.3 (152, 6.0)	21.9 (164, 6.5)

# DIAGNOSTIC TROUBLE CODE (DTC) DETECTING CRITERIA

GENERAL DESCRIPTION

rpm	3200	3600	4000	4400	4800	5200	5600	6000
MT (V. Speed < 64 km/h (40 MPH)) kPa (mmHg, inHg)	22.9 (172, 6.8)	25.1 (188, 7.4)	28.3 (212, 8.3)	31.5 (236, 9.3)	34.7 (260, 10.2)	38.4 (288, 11.3)	41.6 (312, 12.3)	44.8 (336, 13.2)
(V. Speed ≥ 64 km/h (40 MPH)) kPa (mmHg, inHg)	32.5 (244, 9.6)	31.5 (236, 9.3)	31.5 (236, 9.3)	31.5 (236, 9.3)	34.7 (260, 10.2)	38.4 (288, 11.3)	41.6 (312, 12.3)	44.8 (336, 13.2)
AT kPa (mmHg, inHg)	25.1 (188, 7.4)	28.8 (216, 8.5)	32.0 (240, 9.4)	35.2 (264, 10.4)	37.9 (284, 11.2)	41.1 (308, 12.1)	44.3 (332, 13.1)	47.5 (356, 14.0)

### 3. GENERAL DRIVING CYCLE

If the condition matched, detect misfire in the engine speed of idling to high revolution.

### 4. DIAGNOSTIC METHOD

When the misfire occurred, the engine speed is decreased and the crankshaft position speed will change. Calculate the interval difference value (diagnostic value) from crankshaft position speed, and judge whether the misfire occurs or not comparing the calculated result with judgment value.

Calculate the diagnostic value (from crankshaft position speed)	→ Misfire detection every single ignition (Compare diagnostic value with judgment value) <ul style="list-style-type: none"> <li>• 180° Interval Difference Method</li> <li>• 720° Interval Difference Method</li> <li>• Pattern Recognition Method</li> </ul>	→ NG judgment (Judge misfire occurrence required by the law) (Compare number of misfire with judgment) <ul style="list-style-type: none"> <li>• FTP1.5 times misfire NG judgment</li> <li>• Catalyst damage misfire NG judgment</li> </ul>
-----------------------------------------------------------------	---------------------------------------------------------------------------------------------------------------------------------------------------------------------------------------------------------------------------------------------------------------	--------------------------------------------------------------------------------------------------------------------------------------------------------------------------------------------------------------------------------------------

For misfire detection, there are three methods such as 180° Interval Difference Method, 720° Interval Difference Method and Pattern Recognition Method.

#### • 180° Interval Difference Method, 720° Interval Difference Method

Transform the time needed for crankshaft movement from BTDC65° to BTDC10° into revolution. As the following, regard the revolution as MNX0. And then regard the former revolution as MNX1, the second former revolution as MNX2, and the third as MNX3, etc.

Use the detecting method below for misfire patterns, and judge misfire occurrence when the result calculated from the formula is out of threshold value.

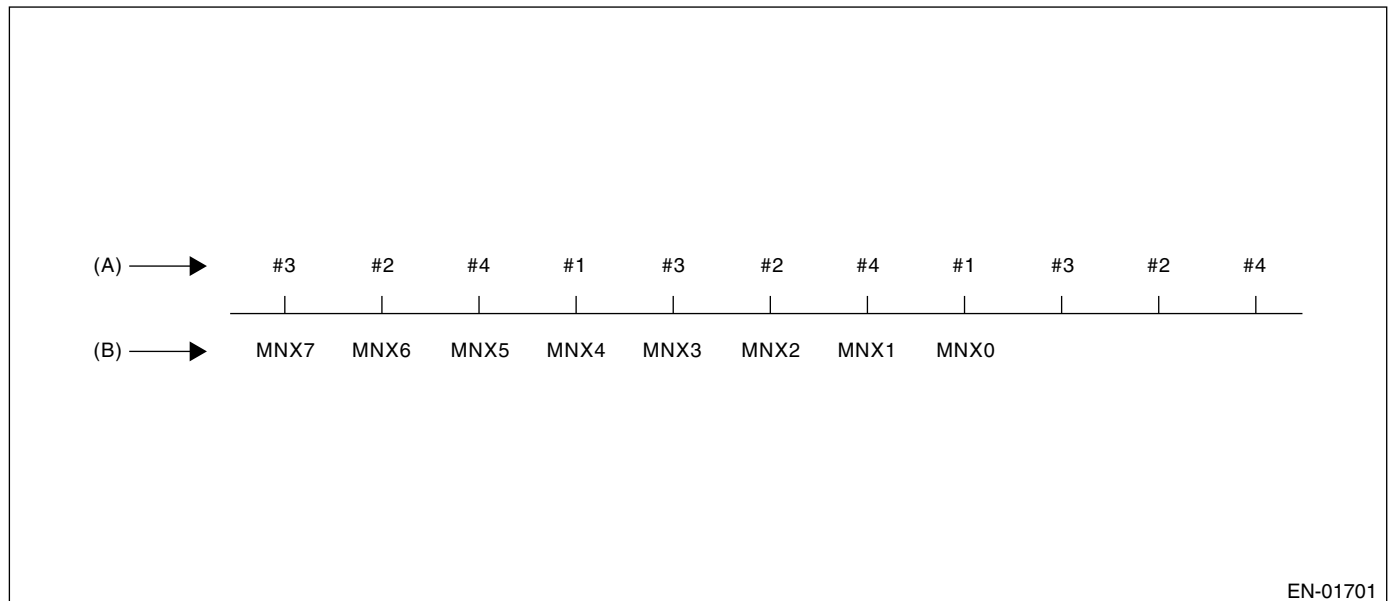

- (A) Ignition order
- (B) Engine speed (rpm)

# DIAGNOSTIC TROUBLE CODE (DTC) DETECTING CRITERIA

## GENERAL DESCRIPTION

### 180° Interval Difference Method (DDNCON0)

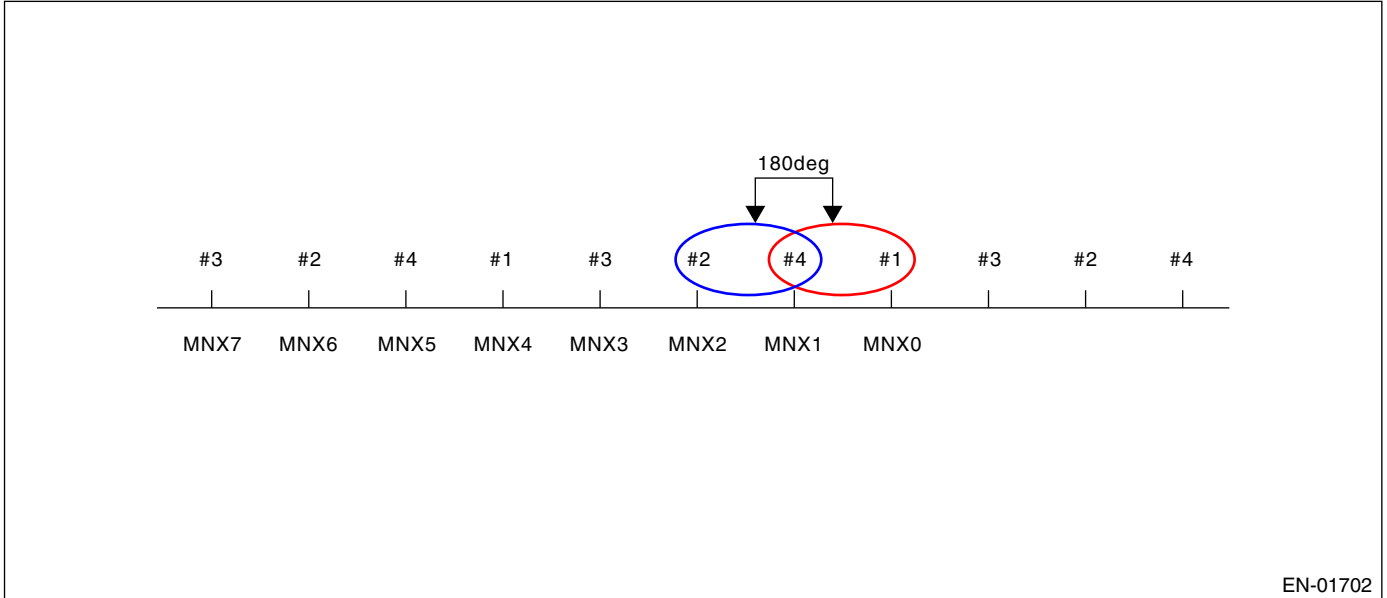

(1)  $DDNCON1 = (MNX\ 1 - MNX\ 2) - (MNX\ 2 - MNX\ 3) \leq \text{Threshold value}$

(2)  $DDNCON0 = (MNX\ 0 - MNX\ 1) - (MNX\ 1 - MNX\ 2) \geq \text{Threshold value}$

Judge misfire when the (1) and (2) above are completed.

### 720° Interval Difference Method (DDNCYL0)

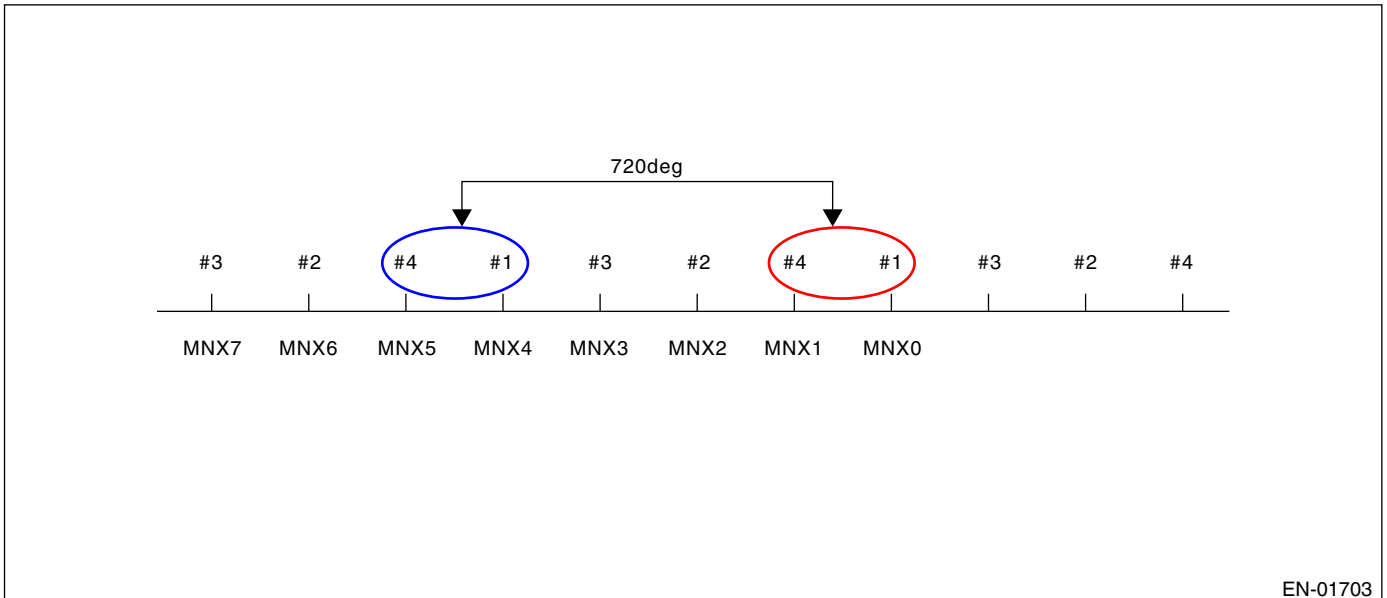

(3)  $DDNCYL4 = (MNX\ 4 - MNX\ 5) - (MNX\ 8 - MNX\ 9) \leq \text{Threshold value}$

(4)  $DDNCYL0 = (MNX\ 0 - MNX\ 1) - (MNX\ 4 - MNX\ 5) \geq \text{Threshold value}$

Judge misfire when the (1) and (2) above are completed.



# DIAGNOSTIC TROUBLE CODE (DTC) DETECTING CRITERIA

GENERAL DESCRIPTION

## • Pattern Recognition Method

Pattern Recognition Method has two patterns such as every time misfire on one cylinder and continuous misfire on two cylinders.

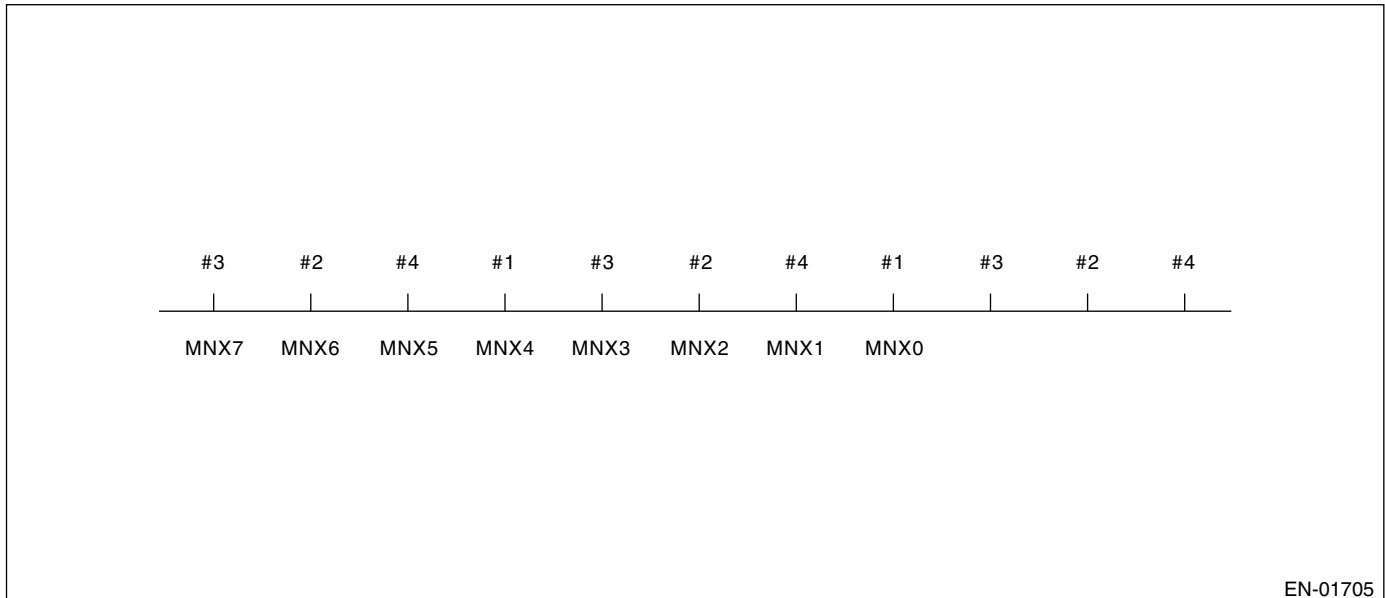

EN-01705

### Every time misfire on one cylinder

Calculate the simple average (calculate MNX 0 – MNX 1) per one hundred ignitions for one cylinder (per four hundred ignitions for four cylinder).

Regard the value calculated for #1 cylinder as AVE1, #2 cylinder as AVE2, and as AVE3, AVE4 like the same way. Judge misfire occurrence when the value calculated from the following formula is larger than threshold value.

(Max. value of AVE1 to AVE4) – AVE<sub>n</sub> (n=1, 2, 3, 4) ≥ threshold value → Judge that misfire occurs.

### Continuous misfire on two cylinders

(1) Two continuous ignitions with “MNX 0 – MNX 1 ≥ threshold value” occurs.

(2) Two continuous ignitions with “MNX 0 – MNX 1 ≤ – (threshold value)” occurs.

Judge misfire occurrence on continuous two cylinders when the judgment criteria (1) and (2) above repeated for four hundred ignition.

### • FTP 1.5 times Misfire (Misfire occurrence level which influences exhaust gas)

Judge malfunction when the misfire rate in 1000 revs. is large.

#### Judgment Value

Malfunction Criteria	Threshold Value
FTP emission	> 1.0% in 1000 revs.

**Time Needed for Diagnosis:** 1000 engine revs.

**Malfunction Indicator Light Illumination:** Twice continuous driving cycles.

### • Catalyst Damage Misfire (Misfire occurrence level which results in catalyst damage)

Judge malfunction when the misfire rate in 200 revs (400 ignitions) is large.

#### Judgment Value

Malfunction Criteria	Threshold Value
Catalyst damage	> See Map 1

# DIAGNOSTIC TROUBLE CODE (DTC) DETECTING CRITERIA

## GENERAL DESCRIPTION

### Map 1 Fault criteria limit for misfire which would result in catalyst damage

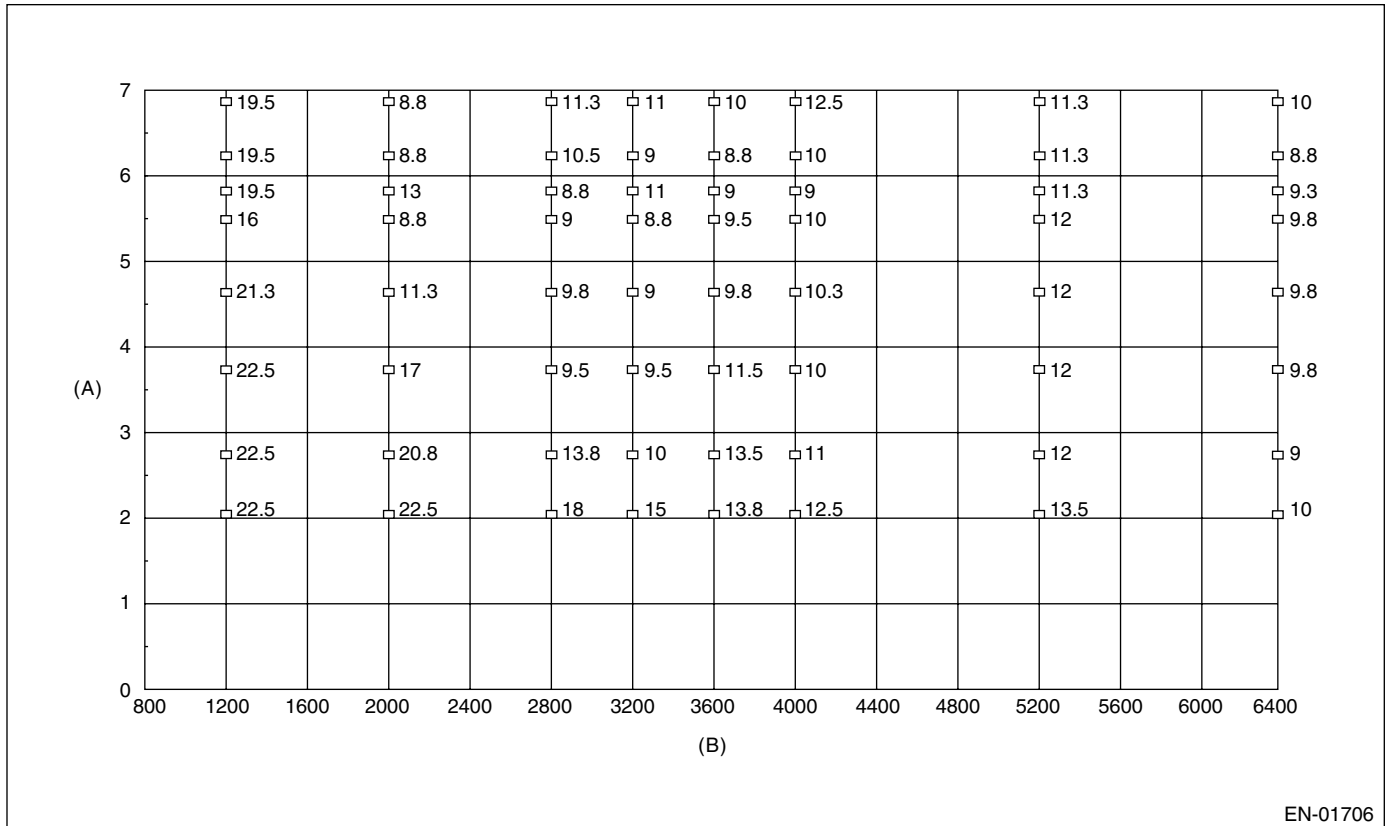

(A) Basic injection pulse (millisecond)

(B) Engine speed (rpm)

\*These figures represent the misfire rate (%) in 400 ignitions.

22.5 (%) means "400 (ignitions) × 22.5 (%) = 90 (ignitions)" or more, and judge misfire.

**Time Needed for Diagnosis:** 200 engine revs.

**Malfunction Indicator Light Illumination:** Illuminates as soon as malfunction occurs.

#### 5. DTC CLEAR CONDITION

- When the OK idling cycle is completed 40 times in a row
- When "Clear Memory" was performed

#### 6. MALFUNCTION INDICATOR LIGHT CLEAR CONDITION

- When diagnosed OK with the similar driving for 3 driving cycles in a row
- When "Clear Memory" was performed

#### 7. FAIL SAFE

None

#### 8. ECM OPERATION AT DTC SETTING

Memorize the freeze frame data. (For test mode \$02)

# DIAGNOSTIC TROUBLE CODE (DTC) DETECTING CRITERIA

GENERAL DESCRIPTION

---

## **AK:DTC P0302 — CYLINDER 2 MISFIRE DETECTED —**

### **1. OUTLINE OF DIAGNOSIS**

For detecting criteria, refer to DTC P0301 — CYLINDER 1 MISFIRE DETECTED —. <Ref. to GD(H4SO)-86, DTC P0301 — CYLINDER 1 MISFIRE DETECTED —, Diagnostic Trouble Code (DTC) Detecting Criteria.>

## **AL:DTC P0303 — CYLINDER 3 MISFIRE DETECTED —**

### **1. OUTLINE OF DIAGNOSIS**

For detecting criteria, refer to DTC P0301 — CYLINDER 1 MISFIRE DETECTED —. <Ref. to GD(H4SO)-86, DTC P0301 — CYLINDER 1 MISFIRE DETECTED —, Diagnostic Trouble Code (DTC) Detecting Criteria.>

## **AM:DTC P0304 — CYLINDER 4 MISFIRE DETECTED —**

### **1. OUTLINE OF DIAGNOSIS**

For detecting criteria, refer to DTC P0301 — CYLINDER 1 MISFIRE DETECTED —. <Ref. to GD(H4SO)-86, DTC P0301 — CYLINDER 1 MISFIRE DETECTED —, Diagnostic Trouble Code (DTC) Detecting Criteria.>

# DIAGNOSTIC TROUBLE CODE (DTC) DETECTING CRITERIA

## GENERAL DESCRIPTION

### AN:DTC P0327 — KNOCK SENSOR 1 CIRCUIT LOW INPUT (BANK 1 OR SINGLE SENSOR) —

#### 1. OUTLINE OF DIAGNOSIS

Detect the open or short circuit of knock sensor.  
Judge NG when out of the standard value.

#### 2. COMPONENT DESCRIPTION

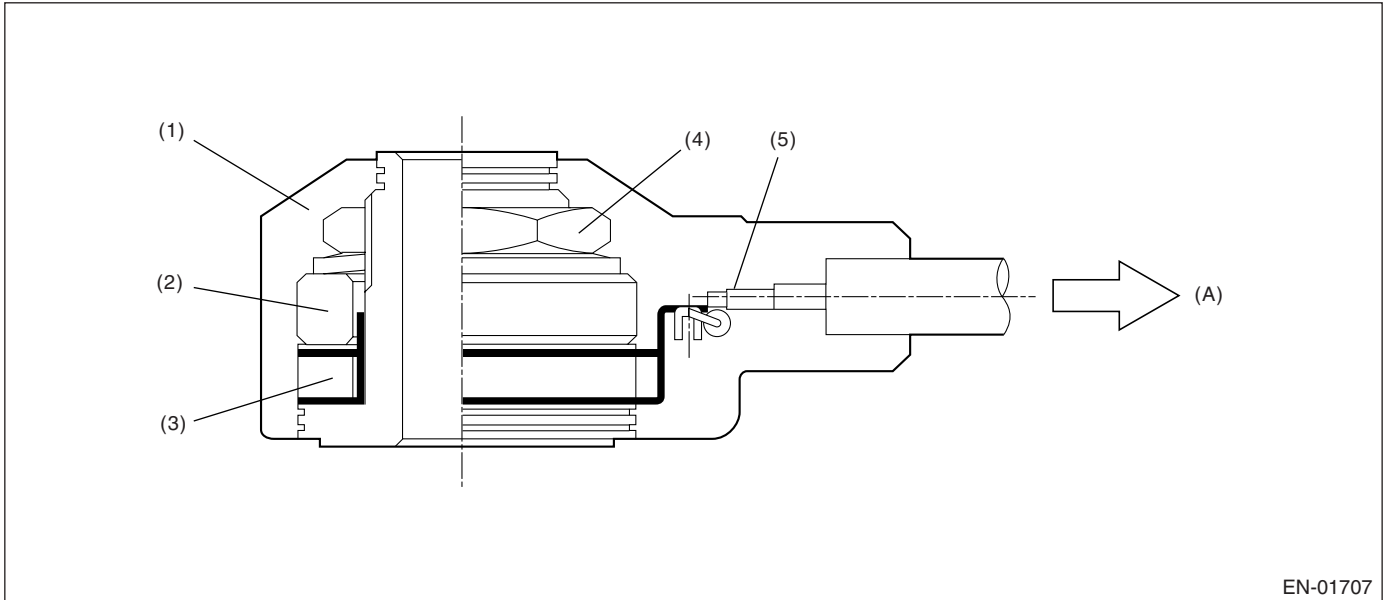

- (1) Case
- (2) Weight
- (3) Piezoelectric element
- (4) Nut
- (5) Resistance

(A) To knock sensor harness

#### 3. ENABLE CONDITION

Secondary Parameters	Enable Conditions
Ignition switch	ON

#### 4. GENERAL DRIVE CYCLE

Always perform the diagnosis continuously after starting the engine.

#### 5. DIAGNOSTIC METHOD

Judge NG when the continuous time until completing the malfunction criteria below becomes more than the time (1 second) needed for diagnosis. Judge OK when the malfunction criteria below are not completed.

##### Judgment Value

Malfunction Criteria	Threshold Value
Output voltage	< 0.6 V

**Time Needed for Diagnosis:** 1 second

**Malfunction Indicator Light Illumination:** Illuminates as soon as malfunction occurs.

# DIAGNOSTIC TROUBLE CODE (DTC) DETECTING CRITERIA

GENERAL DESCRIPTION

---

## 6. DTC CLEAR CONDITION

- When the OK idling cycle is completed 40 times in a row
- When "Clear Memory" was performed

## 7. MALFUNCTION INDICATOR LIGHT CLEAR CONDITION

- When the OK driving cycle was completed 3 times in a row
- When "Clear Memory" was performed

## 8. FAIL SAFE

- (1) Stop whole compensation, partial compensation, knock cancel compensation in ignition timing calculation at normal.
- (2) Knock cancel compensation of low engine coolant temperature is fixed value (7°C).
- (3) Stop partial compensation calculation of ignition leaning.

## 9. ECM OPERATION AT DTC

Memorize the freeze frame data. (For test mode \$02)

# DIAGNOSTIC TROUBLE CODE (DTC) DETECTING CRITERIA

## GENERAL DESCRIPTION

### AO:DTC P0328 — KNOCK SENSOR 1 CIRCUIT HIGH INPUT (BANK 1 OR SINGLE SENSOR) —

#### 1. OUTLINE OF DIAGNOSIS

Detect the open or short circuit of knock sensor.  
Judge NG when out of the standard value.

#### 2. COMPONENT DESCRIPTION

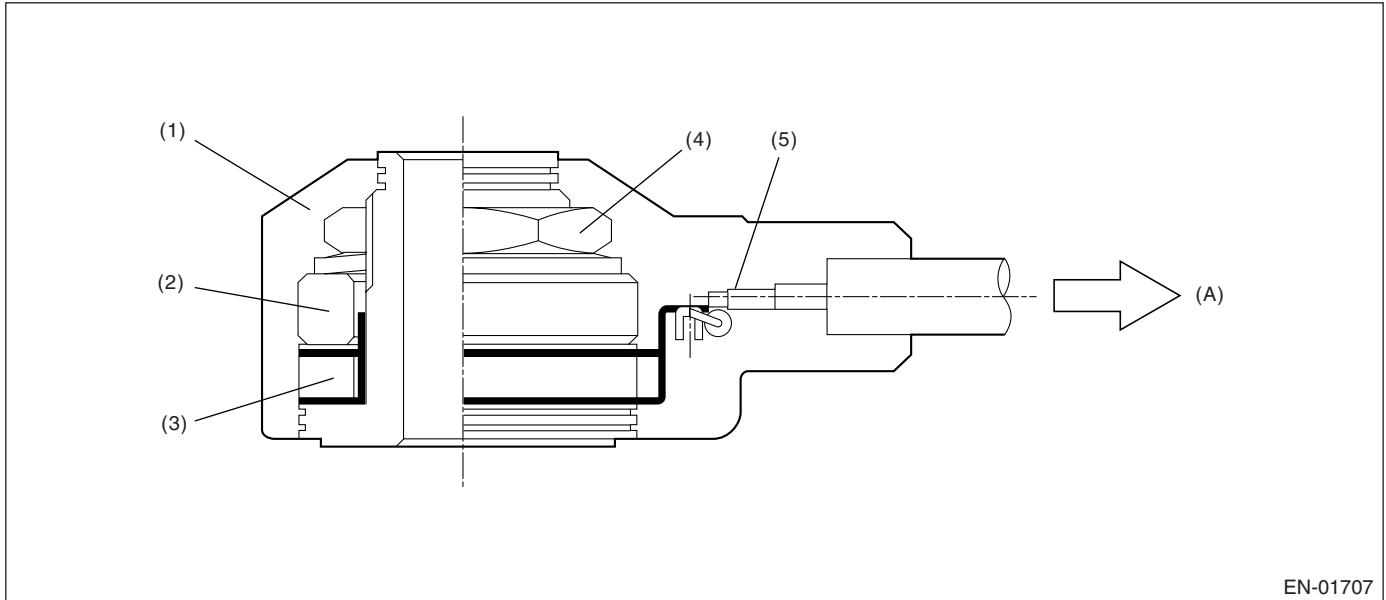

- (1) Case
- (2) Weight
- (3) Piezoelectric element
- (4) Nut
- (5) Resistance

(A) To knock sensor harness

#### 3. ENABLE CONDITION

Secondary Parameters	Enable Conditions
Ignition switch	ON

#### 4. GENERAL DRIVE CYCLE

Always perform the diagnosis continuously after starting the engine.

#### 5. DIAGNOSTIC METHOD

Judge NG when the continuous time of completing the malfunction criteria below becomes more than the time (1 second) needed for diagnosis. Judge OK when the malfunction criteria below are not completed.

##### Judgment Value

Malfunction Criteria	Threshold Value
Output voltage	> 3.5 V

**Time Needed for Diagnosis:** 1 second

**Malfunction Indicator Light Illumination:** Illuminates as soon as malfunction occurs.

# DIAGNOSTIC TROUBLE CODE (DTC) DETECTING CRITERIA

GENERAL DESCRIPTION

---

## 6. DTC CLEAR CONDITION

- When the OK idling cycle is completed 40 times in a row
- When "Clear Memory" was performed

## 7. MALFUNCTION INDICATOR LIGHT CLEAR CONDITION

- When the OK driving cycle was completed 3 times in a row
- When "Clear Memory" was performed

## 8. FAIL SAFE

- (1) Stop whole compensation, partial compensation, knock cancel compensation in ignition timing calculation at normal.
- (2) Knock cancel compensation of low engine coolant temperature is fixed value (7°C).
- (3) Stop partial compensation calculation of ignition leaning.

## 9. ECM OPERATION AT DTC

Memorize the freeze frame data. (For test mode \$02)

# DIAGNOSTIC TROUBLE CODE (DTC) DETECTING CRITERIA

## GENERAL DESCRIPTION

### AP:DTC P0335 — CRANKSHAFT POSITION SENSOR “A” CIRCUIT —

#### 1. OUTLINE OF DIAGNOSIS

Detect the open or short circuit of crankshaft position sensor.

Normally, the crankshaft position sensor signal and camshaft position sensor signal are input as shown below. But judge NG when continuing not to input the crankshaft position sensor signal.

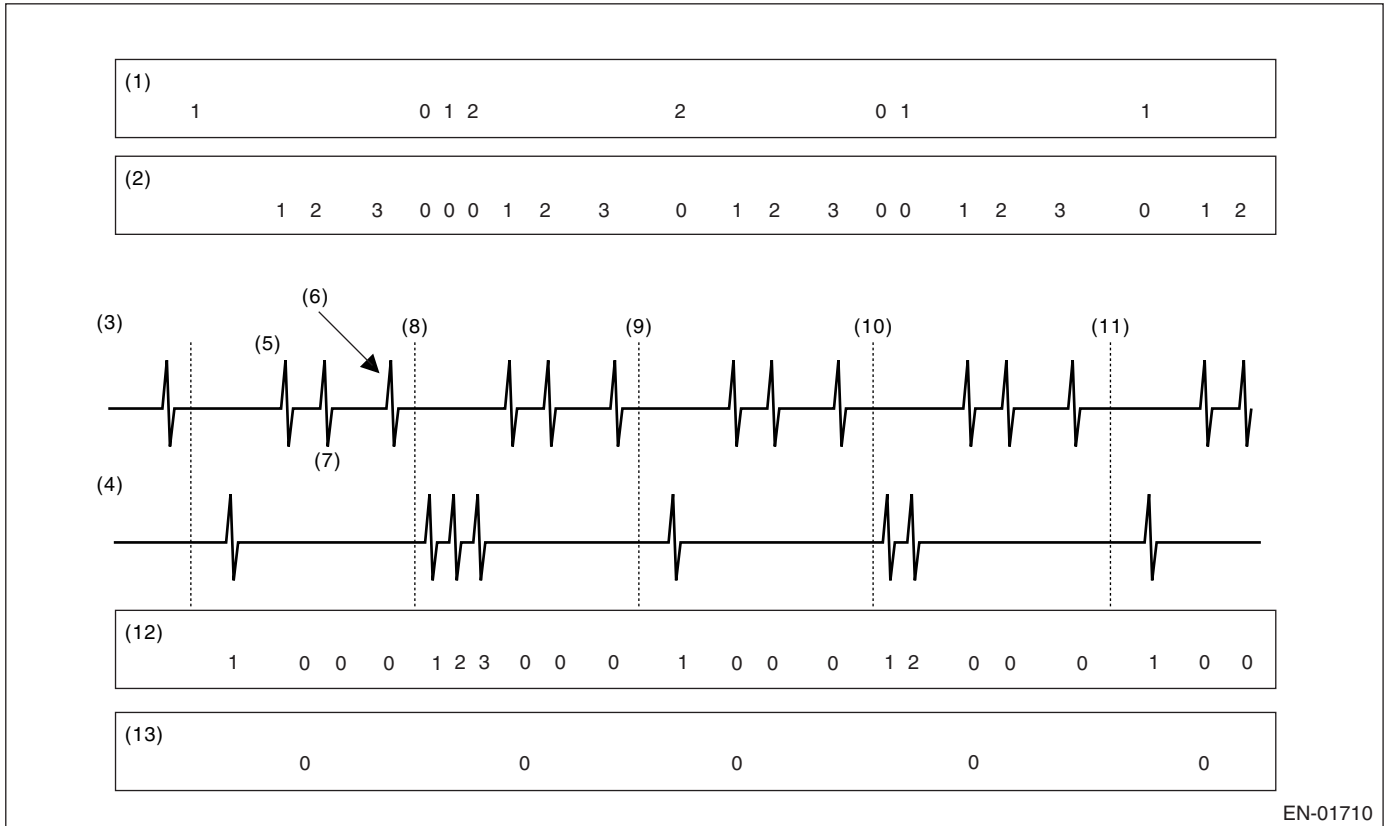

EN-01710

- |                                                |                                               |
|------------------------------------------------|-----------------------------------------------|
| (1) NG counter of crankshaft position sensor   | (8) #1 compression TDC                        |
| (2) Signal count of crankshaft position sensor | (9) #3 compression TDC                        |
| (3) Crankshaft position sensor signal          | (10) #2 compression TDC                       |
| (4) Camshaft position sensor signal            | (11) #4 compression TDC                       |
| (5) BTDC 97°CA                                 | (12) Signal count of camshaft position sensor |
| (6) BTDC 10°CA                                 | (13) NG counter of relative position          |
| (7) BTDC 65°CA                                 |                                               |

#### • Cylinder judgment method

When inputting BTDC97°CA crankshaft position sensor signal, judge what cylinder piston is brought to the top dead center of compression by camshaft position sensor signal number.

Camshaft position sensor signal number	Next top dead center of compression
3	#3
1	#2
2	#4
1	#1



## 2. COMPONENT DESCRIPTION

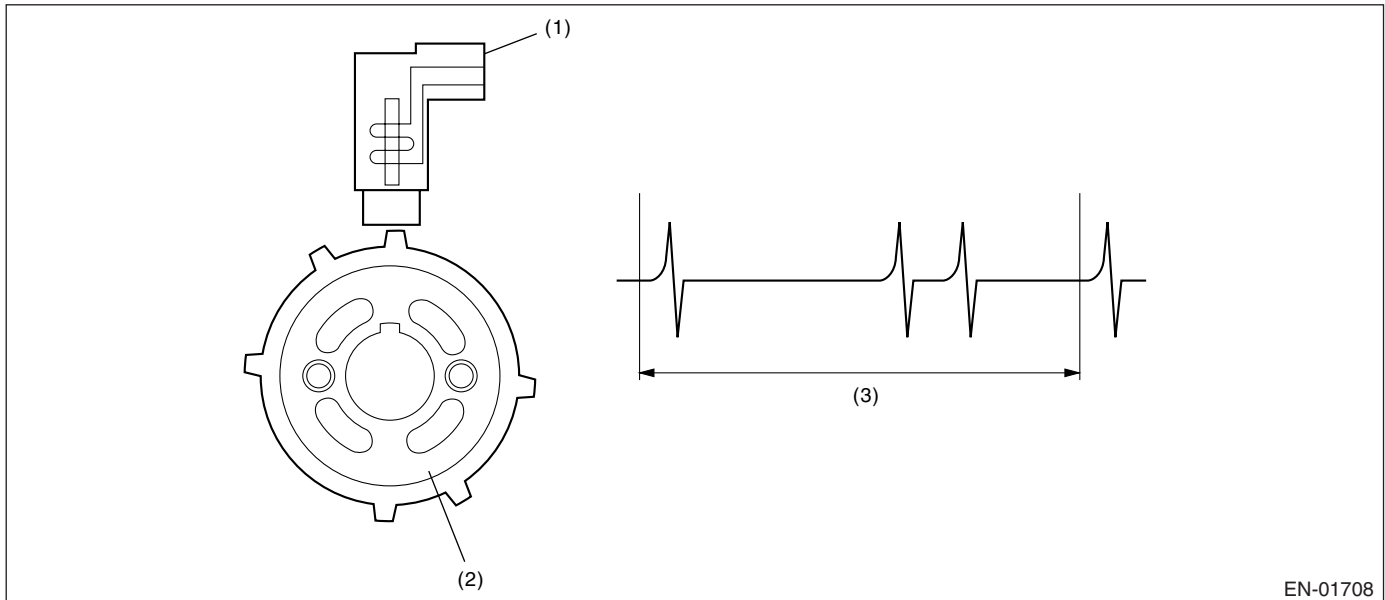

- (1) Crankshaft position sensor
- (2) Crank sprocket
- (3) Crankshaft half-turn

EN-01708

## 3. ENABLE CONDITION

Perform the diagnosis without condition.

## 4. GENERAL DRIVING CYCLE

Perform the diagnosis continuously.

## 5. DIAGNOSTIC METHOD

Judge OK and clear the NG when the malfunction criteria below are completed.

### Judgment Value

Malfunction Criteria	Threshold Value
Camshaft position sensor signal	≥ 24
Crankshaft position sensor signal	Detection when warming

When the crankshaft position sensor signal is input, the camshaft position sensor signal number is cleared.

**Time Needed for Diagnosis:** 7 revs.

**Malfunction Indicator Light Illumination:** Illuminates as soon as malfunction occurs.

## 6. DTC CLEAR CONDITION

- When the OK idling cycle was completed 40 times in a row
- When "Clear Memory" was performed

## 7. MALFUNCTION INDICATOR LIGHT CLEAR CONDITION

- When the OK driving cycle was completed 3 times in a row
- When "Clear Memory" was performed

## 8. FAIL SAFE

None

## 9. ECM OPERATION AT DTC

Memorize the freeze frame data. (For test mode \$02)

# DIAGNOSTIC TROUBLE CODE (DTC) DETECTING CRITERIA

## GENERAL DESCRIPTION

### AQ:DTC P0336 — CRANKSHAFT POSITION SENSOR “A” CIRCUIT RANGE/ PERFORMANCE —

#### 1. OUTLINE OF DIAGNOSIS

Detect the malfunction of crankshaft position sensor output property.

Compare the normal crankshaft position sensor signal with normal camshaft position sensor signal. When each input number does not correspond, judge NG.

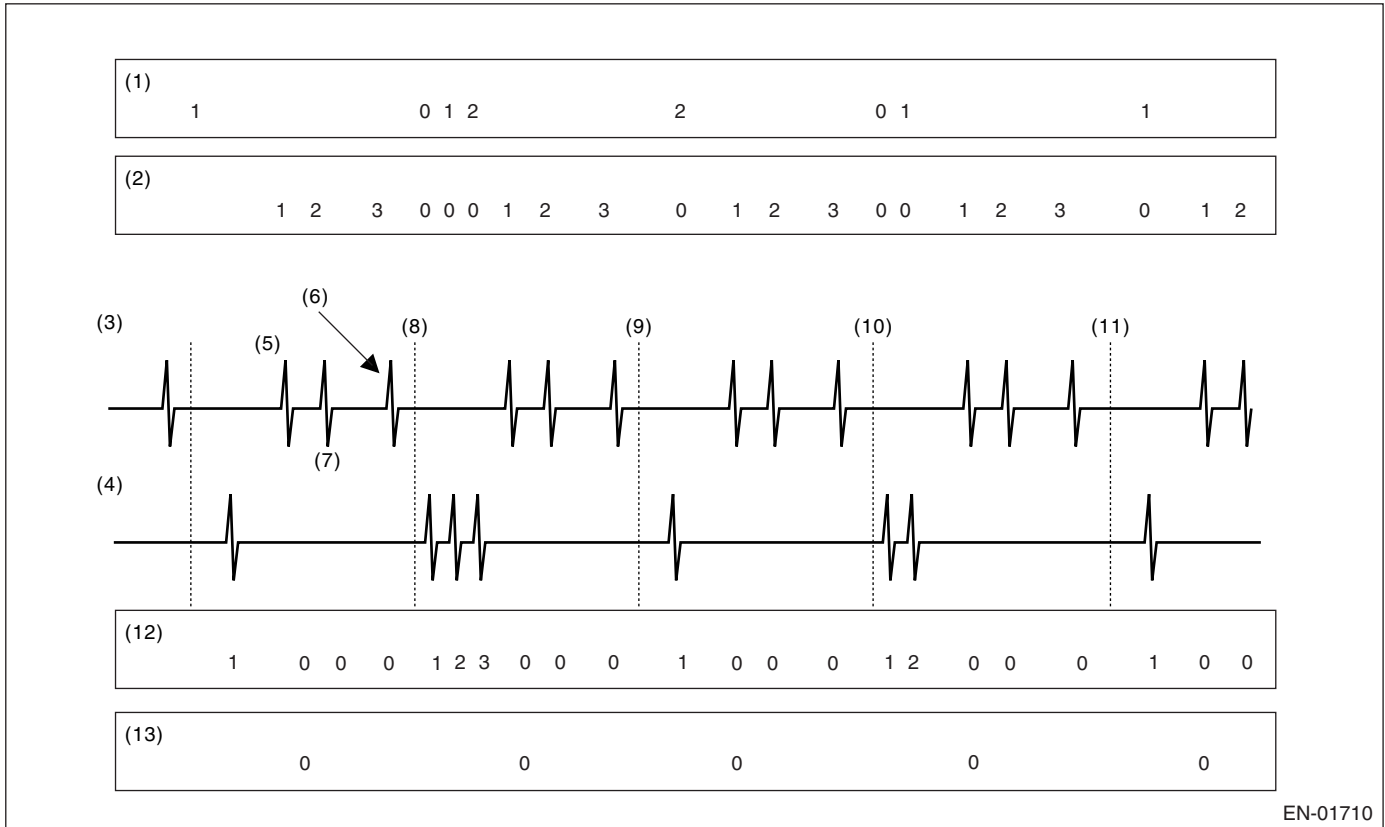

EN-01710

- |                                                |                                               |
|------------------------------------------------|-----------------------------------------------|
| (1) NG counter of crankshaft position sensor   | (8) #1 compression TDC                        |
| (2) Signal count of crankshaft position sensor | (9) #3 compression TDC                        |
| (3) Crankshaft position sensor signal          | (10) #2 compression TDC                       |
| (4) Camshaft position sensor signal            | (11) #4 compression TDC                       |
| (5) BTDC 97°CA                                 | (12) Signal count of camshaft position sensor |
| (6) BTDC 10°CA                                 | (13) NG counter of relative position          |
| (7) BTDC 65°CA                                 |                                               |

#### • Cylinder judgment method

When BTDC97°CA crankshaft position sensor signal is input, judge what cylinder piston is brought to the top dead center of compression by camshaft position sensor signal number.

Camshaft position sensor signal number	Next top dead center of compression
3	#3
1	#2
2	#4
1	#1

## 2. COMPONENT DESCRIPTION

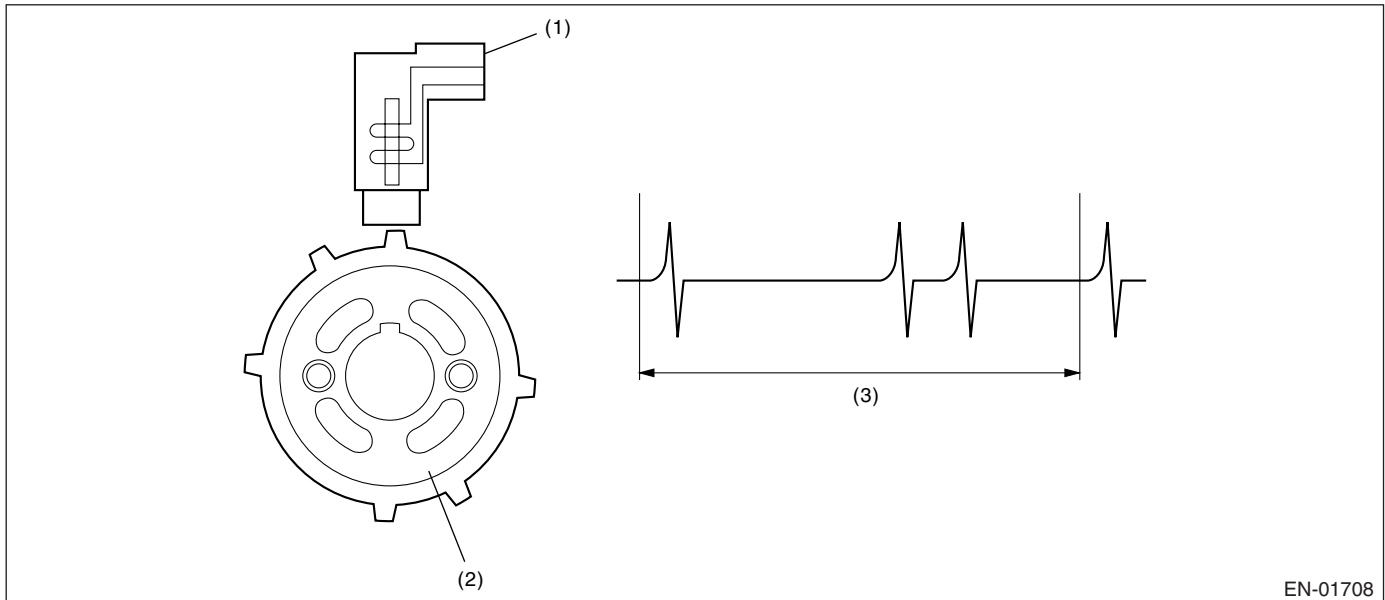

- (1) Crankshaft position sensor
- (2) Crank sprocket
- (3) Crankshaft half-turn

EN-01708

## 3. ENABLE CONDITION

Perform the diagnosis without condition.

## 4. GENERAL DRIVE CYCLE

Perform the diagnosis continuously.

## 5. DIAGNOSTIC METHOD

When the camshaft position sensor signal is input, compare the total crankshaft position sensor signal number from occasion of previous camshaft position sensor signal input to now with crankshaft position sensor signal number at normal. Increase NG judgment counter when each number does not correspond at once. Judge NG when each number does not correspond sequentially (NG counter  $\geq 32$ ). Judge OK and clear NG when the crankshaft position sensor signal number corresponds (NG counter = 0).

### Judgment Value

Malfunction Criteria	Threshold Value
Fault counter	$\geq 32$

**Time Needed for Diagnosis:** 10 revs.

**Malfunction Indicator Light Illumination:** Illuminates as soon as malfunction occurs.

## 6. DTC CLEAR CONDITION

- When the OK idling cycle was completed 40 times in a row
- When "Clear Memory" was performed

## 7. MALFUNCTION INDICATOR LIGHT CLEAR CONDITION

- When the OK driving cycle was completed 3 times in a row
- When "Clear Memory" was performed

## 8. FAIL SAFE

None

# DIAGNOSTIC TROUBLE CODE (DTC) DETECTING CRITERIA

## GENERAL DESCRIPTION

---

### 9. ECM OPERATION AT DTC

Memorize the freeze frame data. (For test mode \$02)

# DIAGNOSTIC TROUBLE CODE (DTC) DETECTING CRITERIA

GENERAL DESCRIPTION

## AR:DTC P0340 — CAMSHAFT POSITION SENSOR “A” CIRCUIT (BANK 1 OR SINGLE SENSOR) —

### 1. OUTLINE OF DIAGNOSIS

Detect the malfunction of crankshaft position sensor output property.

Judge NG when continuing not to input the camshaft position sensor signal.

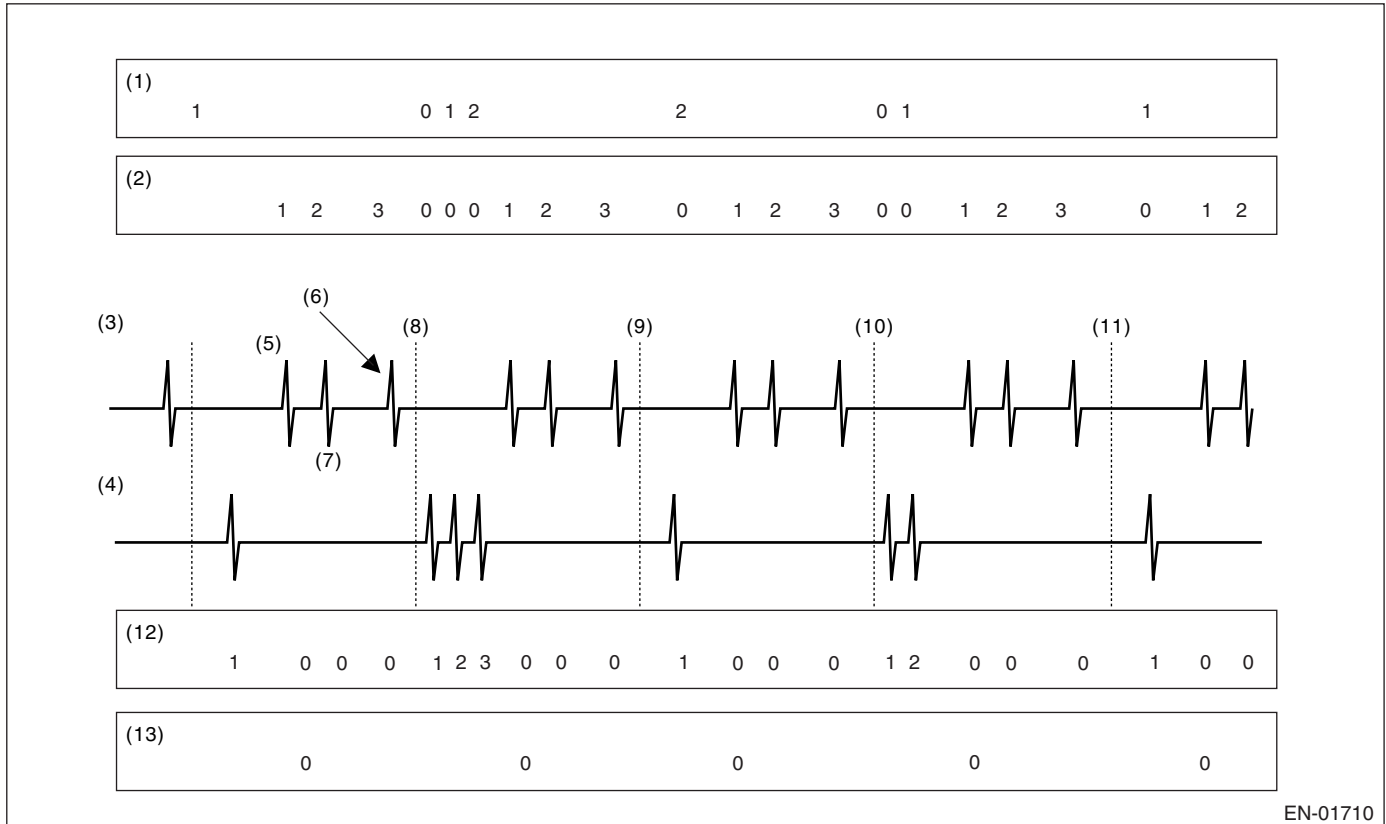

EN-01710

- (1) NG counter of crankshaft position sensor
- (2) Signal count of crankshaft position sensor
- (3) Crankshaft position sensor signal
- (4) Camshaft position sensor signal
- (5) BTDC 97°CA
- (6) BTDC 10°CA
- (7) BTDC 65°CA
- (8) #1 compression TDC
- (9) #3 compression TDC
- (10) #2 compression TDC
- (11) #4 compression TDC
- (12) Signal count of camshaft position sensor
- (13) NG counter of relative position

#### • Cylinder judgment method

When BTDC97°CA crankshaft position sensor signal is input, judge what cylinder piston is brought to the top dead center of compression by camshaft position sensor signal number.

Camshaft position sensor signal number	Next top dead center of compression
3	#3
1	#2
2	#4
1	#1

# DIAGNOSTIC TROUBLE CODE (DTC) DETECTING CRITERIA

## GENERAL DESCRIPTION

### 2. COMPONENT DESCRIPTION

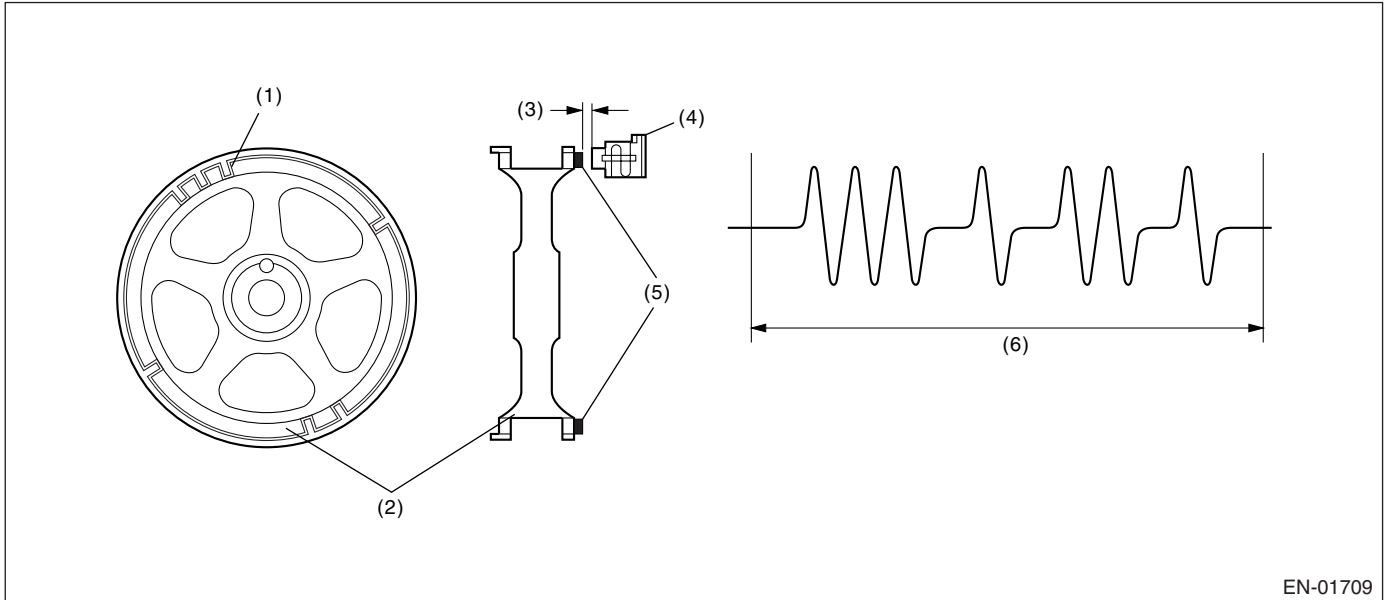

- (1) Boss
- (2) Cam sprocket
- (3) Air gap

- (4) Camshaft position sensor
- (5) Boss
- (6) Camshaft one turn (Crankshaft two turns)

### 3. ENABLE CONDITION

Perform the diagnosis without condition.

### 4. GENERAL DRIVING CYCLE

Perform the diagnosis continuously.

### 5. DIAGNOSTIC METHOD

When many crankshaft position sensor signals were input without camshaft position sensor signal input, judge OK and clear NG.

#### Judgment Value

Malfunction Criteria	Threshold Value
Crankshaft position sensor signal	$\geq 36$
Camshaft position sensor signal	Detection when warming

**Time Needed for Diagnosis:** 6 revs.

**Malfunction Indicator Light Illumination:** Illuminates as soon as malfunction occurs.

### 6. DTC CLEAR CONDITION

- When the OK idling cycle was completed 40 times in a row
- When "Clear Memory" was performed

### 7. MALFUNCTION INDICATOR LIGHT CLEAR CONDITION

- When the OK driving cycle was completed 3 times in a row
- When "Clear Memory" was performed

### 8. FAIL SAFE

None

### 9. ECM OPERATION AT DTC

Memorize the freeze frame data. (For test mode \$02)

# DIAGNOSTIC TROUBLE CODE (DTC) DETECTING CRITERIA

GENERAL DESCRIPTION

## AS:DTC P0341 — CAMSHAFT POSITION SENSOR “A” CIRCUIT RANGE/PERFORMANCE (BANK 1 OR SINGLE SENSOR) —

### 1. OUTLINE OF DIAGNOSIS

Detect the malfunction of crankshaft position sensor output property.

Compare the normal crankshaft position sensor signal with normal camshaft position sensor signal. When each input number does not correspond, judge NG.

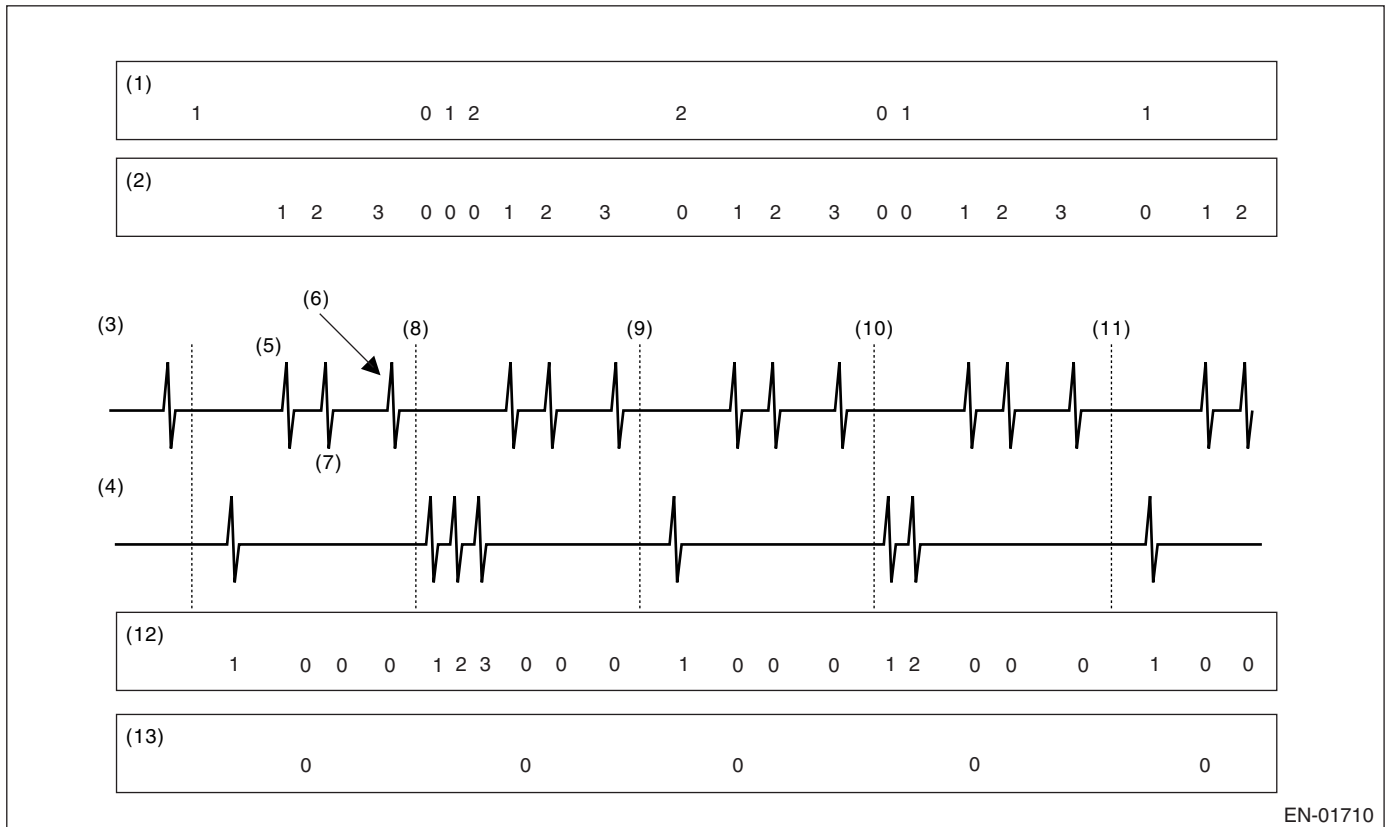

EN-01710

- |                                                |                                               |
|------------------------------------------------|-----------------------------------------------|
| (1) NG counter of crankshaft position sensor   | (8) #1 compression TDC                        |
| (2) Signal count of crankshaft position sensor | (9) #3 compression TDC                        |
| (3) Crankshaft position sensor signal          | (10) #2 compression TDC                       |
| (4) Camshaft position sensor signal            | (11) #4 compression TDC                       |
| (5) BTDC 97°CA                                 | (12) Signal count of camshaft position sensor |
| (6) BTDC 10°CA                                 | (13) NG counter of relative position          |
| (7) BTDC 65°CA                                 |                                               |

#### • Cylinder judgment method

When BTDC97°CA crankshaft position sensor signal is input, judge what cylinder piston is brought to the top dead center of compression by camshaft position sensor signal number.

Camshaft position sensor signal number	Next top dead center of compression
3	#3
1	#2
2	#4
1	#1

# DIAGNOSTIC TROUBLE CODE (DTC) DETECTING CRITERIA

## GENERAL DESCRIPTION

### 2. COMPONENT DESCRIPTION

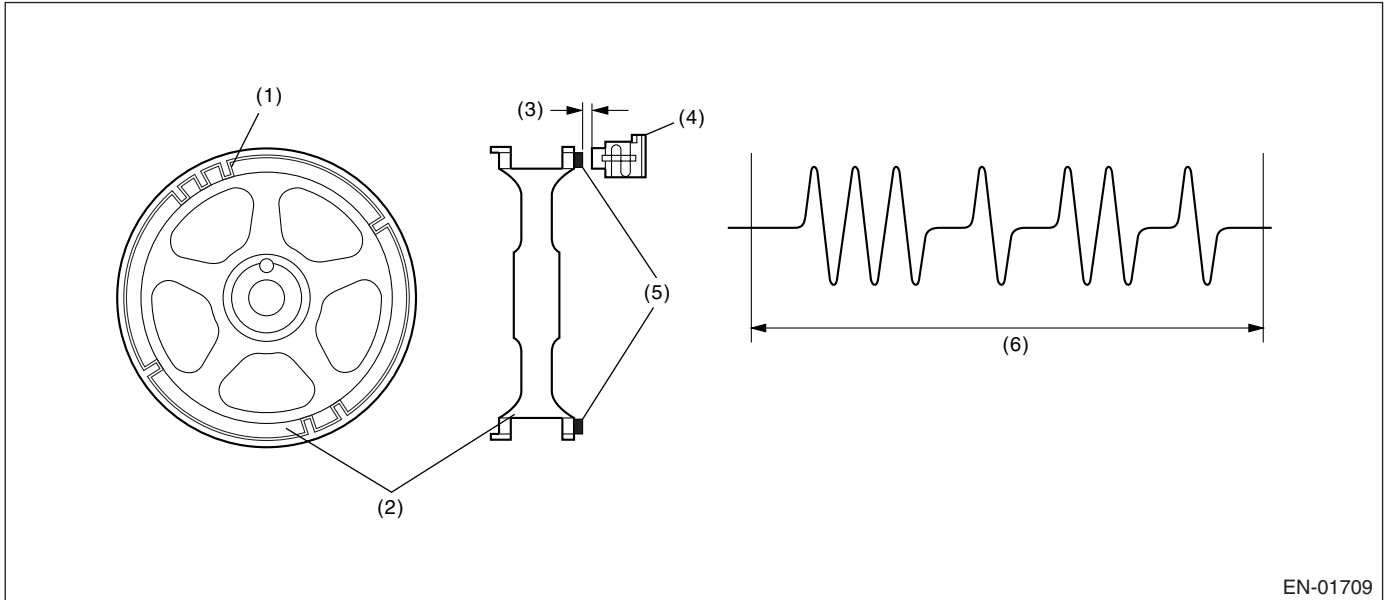

- (1) Boss
- (2) Cam sprocket
- (3) Air gap

- (4) Camshaft position sensor
- (5) Boss
- (6) Camshaft one turn (Crankshaft two turns)

EN-01709

### 3. ENABLE CONDITION

Perform the diagnosis without condition.

### 4. GENERAL DRIVE CYCLE

Always perform the diagnosis continuously.

### 5. DIAGNOSTIC METHOD

When BTDC97°CA crankshaft position sensor signal is input, compare the camshaft position sensor signal number in past 4 times with camshaft position sensor signal number at normal. Increase NG judgment counter when each number does not correspond at once, judge OK and clear NG when the camshaft position sensor signal is normal.

#### Judgment Value

Malfunction Criteria	Threshold Value
Fault counter	≥ 32

**Time Needed for Diagnosis:** 6 revs.

**Malfunction Indicator Light Illumination:** Illuminates as soon as malfunction occurs.

### 6. DTC CLEAR CONDITION

- When the OK idling cycle was completed 40 times in a row
- When "Clear Memory" was performed

### 7. MALFUNCTION INDICATOR LIGHT CLEAR CONDITION

- When the OK driving cycle was completed 3 times in a row
- When "Clear Memory" was performed

### 8. FAIL SAFE

None

### 9. ECM OPERATION AT DTC

Memorize the freeze frame data. (For test mode \$02)



# DIAGNOSTIC TROUBLE CODE (DTC) DETECTING CRITERIA

GENERAL DESCRIPTION

## AT:DTC P0400 — EGR SYSTEM —

### 1. OUTLINE OF DIAGNOSIS

Detect the malfunction of EGR system.

Intake manifold pressure (negative pressure) is stable because the throttle valve is fully closed during the fuel shut-off in deceleration. In this case, the intake manifold pressure changes when EGR valve is opened or closed. Judge EGR system is OK or NG according to intake manifold pressure change amount.

### 2. COMPONENT DESCRIPTION

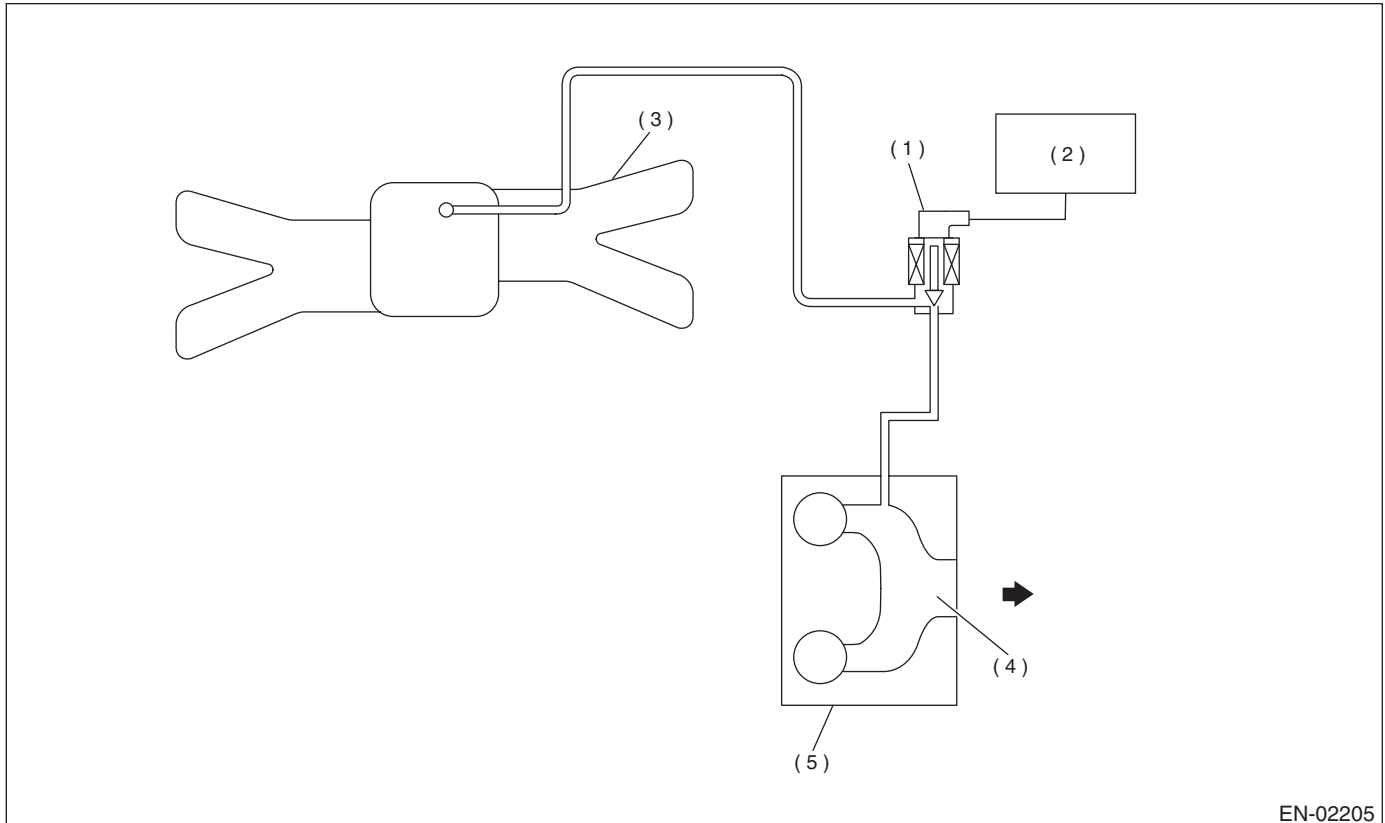

EN-02205

- (1) EGR valve
- (2) Engine control module (ECM)
- (3) Intake manifold

- (4) Exhaust port
- (5) Cylinder head LH

# DIAGNOSTIC TROUBLE CODE (DTC) DETECTING CRITERIA

## GENERAL DESCRIPTION

---

### 3. ENABLE CONDITIONS

Secondary Parameters	Enable Conditions
After engine starting	40 secs. or more
Engine coolant temperature	≥ 75°C (167°F)
Engine speed	1,200 — 2,500 rpm
Intake manifold pressure	13.3 — 34.3 kPa (100 — 257 mmHg, 3.9 — 10.1 inHg)
Estimated ambient temperature	≥ 5°C (41°F)
Throttle position	< 1°
Battery voltage	> 10.9 V
Atmospheric pressure	75.7 kPa (568 mmHg, 22.4 inHg)
Vehicle speed	≥ 40 km/h (25 MPH)
Fuel shut-off function	Operation
Neutral switch	Off or 1 second chang- ing from “on” to “off”
After load input switch operation (air con- ditioner, power steering, lights, rear defroster, heater fan and radiator fan)	5 secs. or more

### 4. GENERAL DRIVING CYCLE

Perform the diagnosis only once at the fuel shut-off in deceleration in vehicle speed more than 40 km/h (25 MPH). Pay attention to vehicle speed and engine speed. (The diagnosis is not completed if vehicle speed and engine speed are out of condition due to deceleration.)

### 5. DIAGNOSTIC METHOD

Measure the pressure in the following procedures when the enable conditions are completed, and then diagnosis by calculating the result.

(1) PMOF1 is equal to the intake manifold pressure at enable condition completed, and EGR target step is set to 50 steps (almost fully opened).

(2) PMON is equal to the intake manifold pressure in 1 second after EGR target step is set 50 steps (when enable conditions are completed), and EGR target step is set to 0 step.

# DIAGNOSTIC TROUBLE CODE (DTC) DETECTING CRITERIA

GENERAL DESCRIPTION

(3) PMOF2 is equal to the intake manifold pressure in 1 second after EGR target step is set to 0 step (in 2 seconds after enable conditions are completed).

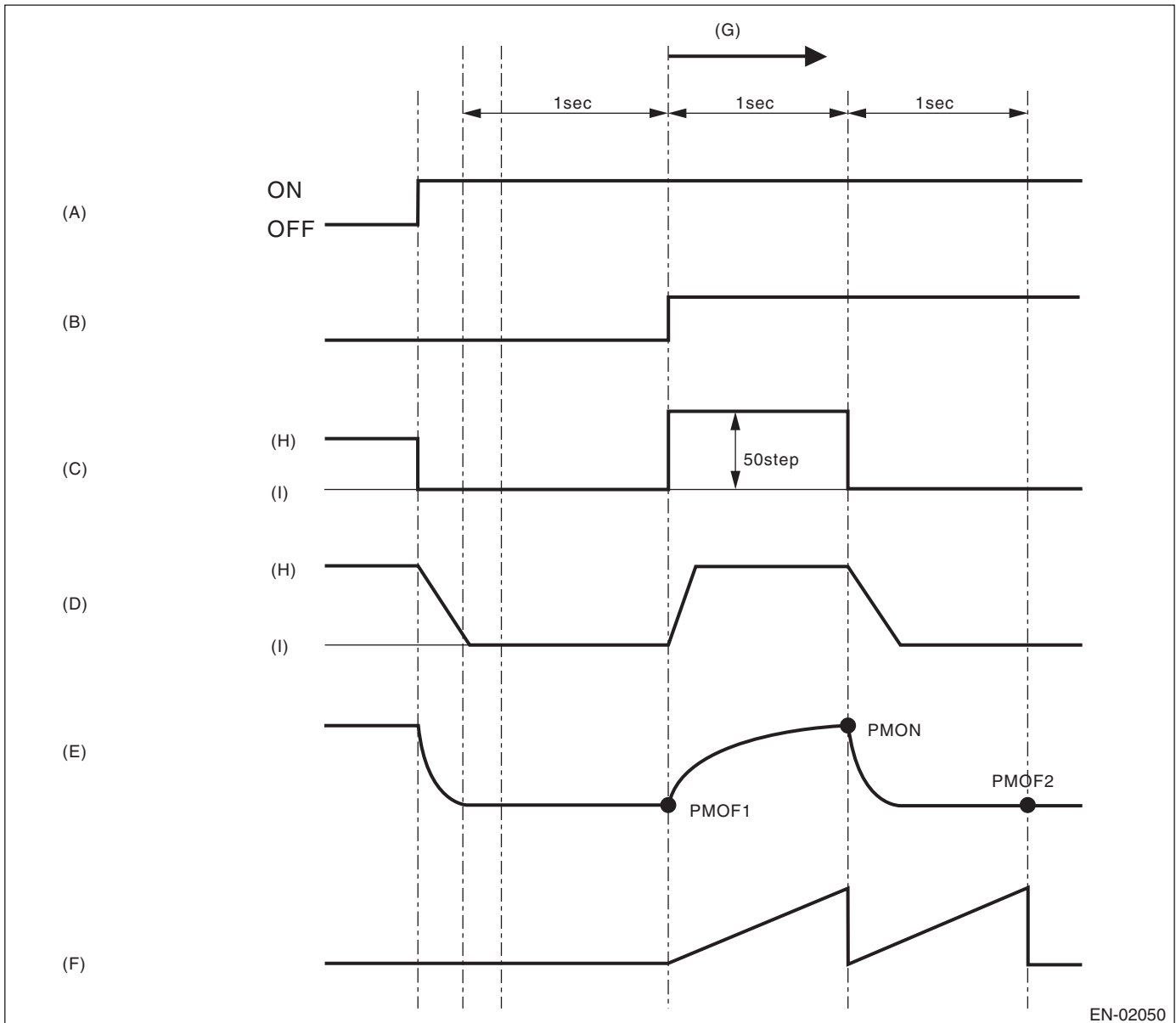

EN-02050

- (A) Fuel shut-off in deceleration
- (B) Diagnosis enable condition
- (C) EGR target step
- (D) EGR actual step
- (E) Intake manifold pressure (At normal condition)
- (F) Diagnosis mode timer
- (G) Diagnosis starts
- (H) Open
- (I) Close

Calculate the judged value using the following formula.

$$\text{Judged value} = [\text{PMON} - (\text{PMOF1} + \text{PMOF2})/2]$$

Judge NG when the malfunction criteria bellows are completed. Judge OK and clear NG when the malfunction criteria bellow are not completed.

### Judgment Value

Malfunction Criteria	Threshold Value	DTC
Judged value	< 1.3 Kpa (10 mmHg, 0.4 inHg)	P0400

**Time Needed for Diagnosis:** 3 seconds

# DIAGNOSTIC TROUBLE CODE (DTC) DETECTING CRITERIA

## GENERAL DESCRIPTION

---

**Malfunction Indicator Light Illumination:** Illuminates when malfunction occurs in 2 continuous driving cycles.

### 6. DTC CLEAR CONDITION

- When the OK idling cycle was completed 40 times in a row
- When "Clear Memory" was performed

### 7. MALFUNCTION INDICATOR LIGHT CLEAR CONDITION

- When the OK driving cycle was completed 3 times in a row
- When "Clear Memory" was performed

### 8. FAIL SAFE

None

### 9. ECM OPERATION AT DTC SETTING

- Memorize the freeze frame data. (For test mode \$02)
- Memorize the diagnostic value and trouble standard value. (For test mode \$06)

## AU:DTC P0420 — CATALYST SYSTEM EFFICIENCY BELOW THRESHOLD (BANK 1) —

### 1. OUTLINE OF DIAGNOSIS

Check the catalyst efficiency deterioration.

Generally, the catalytic converter exhaust gas conversion efficiency and oxygen absorbing/removing function are inter-related. The front A/F sensor and rear oxygen sensor are therefore utilized to monitor the oxygen absorbing/removing function, and the results are used to monitor the conversion efficiency.

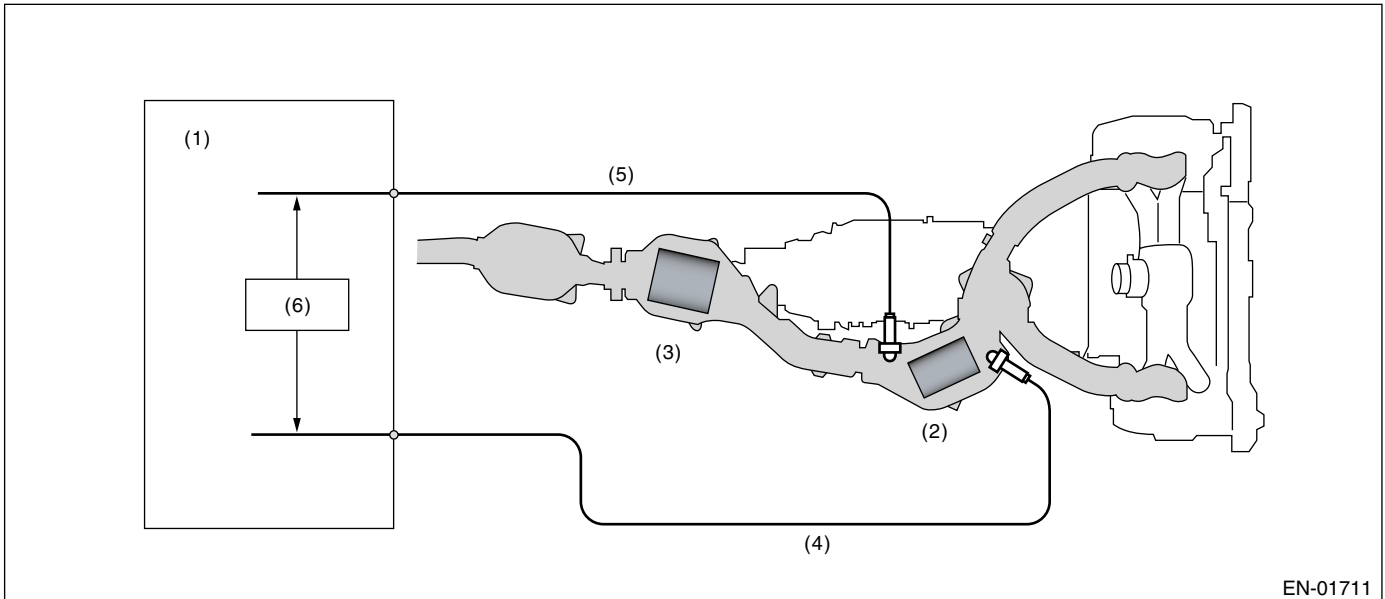

EN-01711

- (1) Engine control module (ECM)
- (2) Front catalyst converter
- (3) Rear catalyst converter

- (4) Front oxygen (A/F) sensor
- (5) Rear oxygen sensor
- (6) Diagnosis circuit

# DIAGNOSTIC TROUBLE CODE (DTC) DETECTING CRITERIA

## GENERAL DESCRIPTION

Oil adherence to the catalytic metal (an alloy of platinum and rhodium, or an alloy of platinum, rhodium and palladium) in catalyst converter or metal melting by extraordinary high temperature result in the decrease of metal surface area contacting exhaust gas. Eventually, catalytic conversion efficiency blunted and oxygen density of catalyst downstream may change.

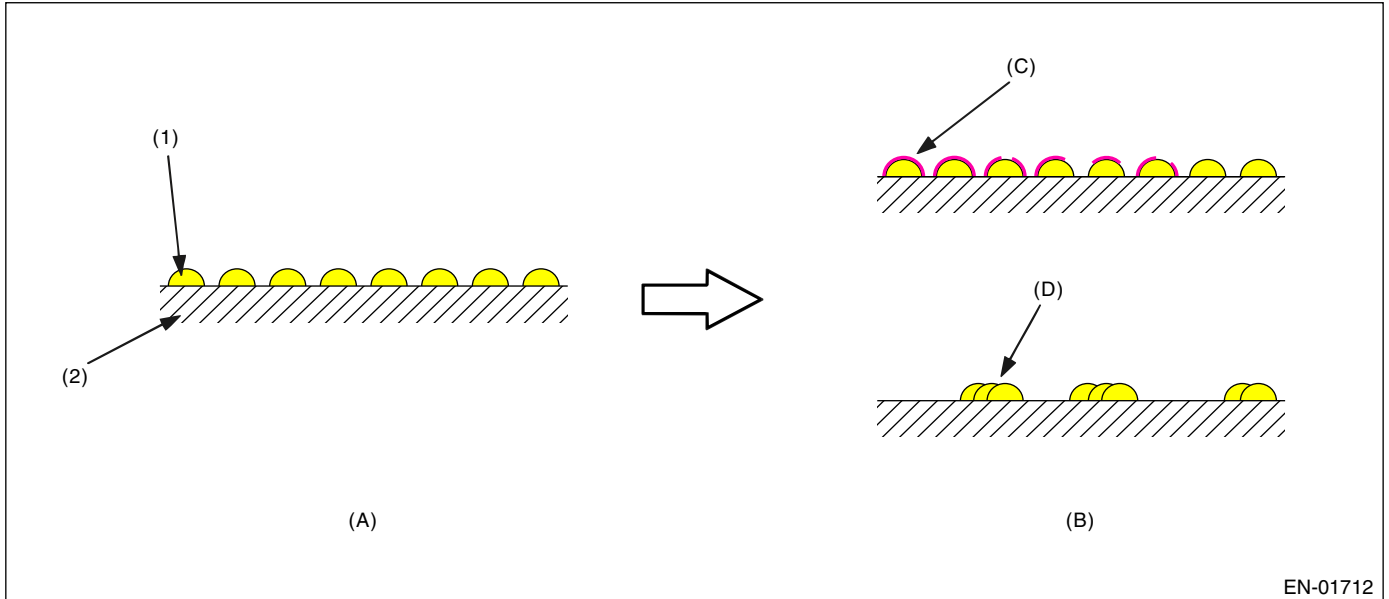

EN-01712

(1) Metal (catalytic function)

(2) Monolith

(A) Normal

(B) Deterioration

(C) Oil adherence

(D) Metal melting by high temperature

# DIAGNOSTIC TROUBLE CODE (DTC) DETECTING CRITERIA

GENERAL DESCRIPTION

Output of rear oxygen sensor changes gradually with a new catalyst, but the blunted catalyst efficiency mentioned above makes sensor output larger and inverse time shorter.

Therefore, catalyst diagnosis is conducted by monitoring the rear oxygen sensor output and comparing its output with the front A/F sensor output.

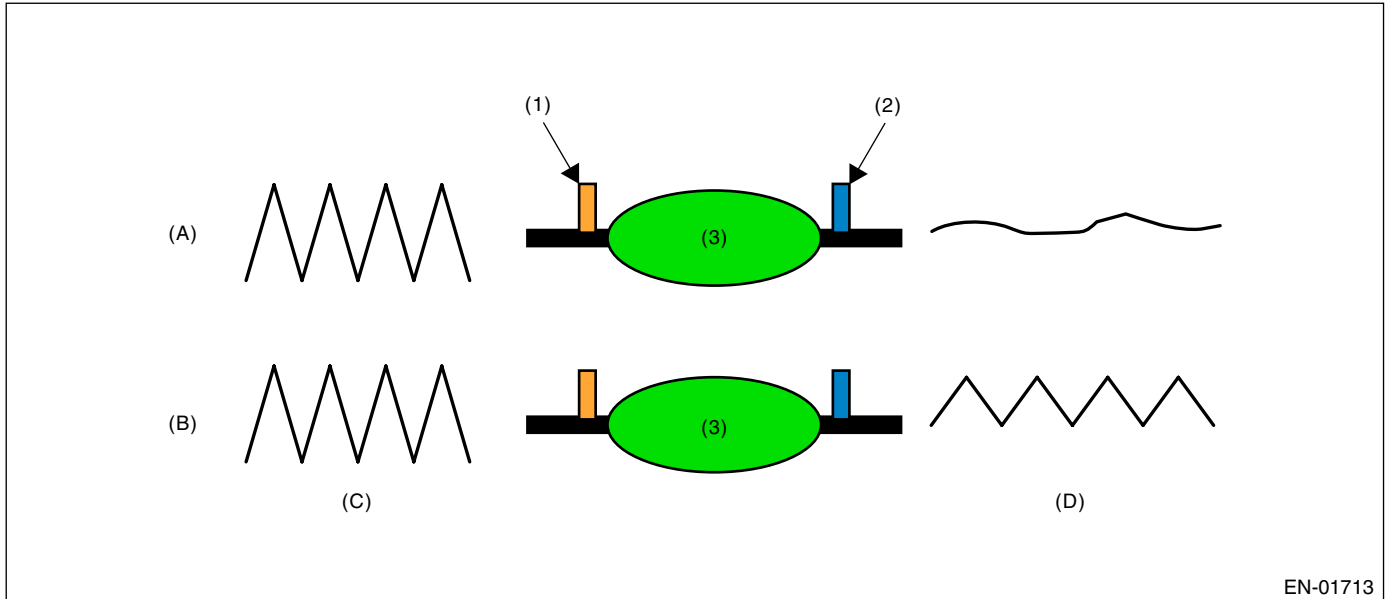

- (1) Front oxygen (A/F) sensor
- (2) Rear catalyst converter
- (3) Catalytic converter

- (A) Normal
- (B) Deterioration
- (C) Output waveform from the front oxygen (A/F) sensor
- (D) Output waveform from the rear oxygen sensor

# DIAGNOSTIC TROUBLE CODE (DTC) DETECTING CRITERIA

## GENERAL DESCRIPTION

---

### 2. ENABLE CONDITION

Secondary Parameters	Enable Conditions
Idle switch off after coolant temp 71°C (160°F)	180 seconds
Closed loop control continuous 5 seconds	Not in standstill
Vehicle speed	24 — 140 km/h (15 — 87 MPH)
Injector pulse (AT)	0.832 — 4.096 milliseconds
(MT)	0.384 — 3.840 milliseconds
Closed loop control with rear oxygen sensor	Operating
Engine misfire during 400 ignitions	≤ 5 times
Lambda	0.625 — 1.375
Engine speed (AT)	600 — 3000 rpm
(MT)	1000 — 3300 rpm
Neutral position	OFF
Engine coolant temperature	≥ 75°C (167°F)
Throttle position (AT)	< 14.72°
(MT)	< 17.60°
Average AIA during diagnosis	≥ 35.2 kg/h
Integrated fluctuating AIA during diagnosis	> 160 kg/h
After fuel shut-off finished	1 second or more
Accumulated amount of intake air (AIA) (start condition)	0.84 kg (1.85 lb)/60 seconds
Vehicle speed (continuous 80 seconds) (start condition)	≥ 20 km/h (12 MPH)
Injector pulse (continuous 40 seconds) (start condition)	1.34 — 4.22 milliseconds
Vehicle speed (continuous 70 seconds) (start condition)	≥ 74 km/h (46 MPH)

### 3. GENERAL DRIVING CYCLE

Perform the diagnosis once with a constant vehicle speed more than 74 km/h (46 MPH).



## 4. DIAGNOSTIC METHOD

### • Output fluctuation accumulate method

The accumulated value of front oxygen (A/F) sensor output changes and the accumulated value of rear oxygen sensor output changes are determined, and the diagnostic value is calculated using the following formula.

Diagnostic value = Accumulated value of rear oxygen sensor output changes / Accumulated value of front oxygen (A/F) sensor output changes

**For example**

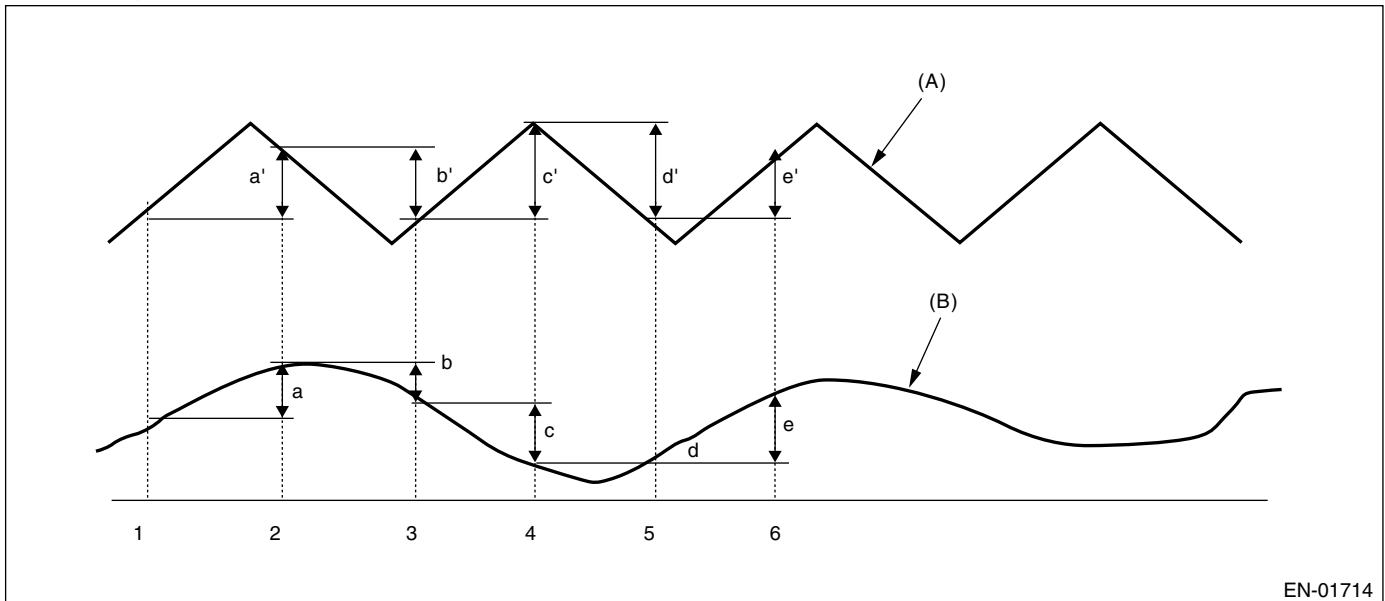

(A) Front oxygen (A/F) sensor output waveform

(B) Rear oxygen sensor output waveform

Judge NG when the malfunction criteria below are completed, and judge OK when they are not completed.

### Judgment Value

Malfunction Criteria	Threshold Value
Accumulated variation of output Voltage of rear oxygen sensor per 50 milliseconds divided by accumulated Variation of output voltage of front lambda sensor per 50 milliseconds	$\geq 1.5$

**Time Needed for Diagnosis:** 45 seconds

**Malfunction Indicator Light Illumination:** Twice continuous driving cycles.

## 5. DTC CLEAR CONDITION

- When the OK idling cycle is completed 40 times in a row
- When "Clear Memory" was performed

## 6. MALFUNCTION INDICATOR LIGHT CLEAR CONDITION

- When the OK driving cycle is completed 3 times in a row
- When "Clear Memory" was performed

## 7. FAIL SAFE

None

## 8. ECM OPERATION AT DTC SETTING

- Memorize the freeze frame data. (For test mode \$02)
- Memorize the diagnosis value and trouble standard value. (For test mode \$06)

# DIAGNOSTIC TROUBLE CODE (DTC) DETECTING CRITERIA

## GENERAL DESCRIPTION

### AV:DTC P0442 — EVAPORATIVE EMISSION CONTROL SYSTEM LEAK DETECTED (SMALL LEAK) —

#### 1. OUTLINE OF DIAGNOSIS

Check if there is a leakage in fuel system or not, and perform the function diagnosis of valve.

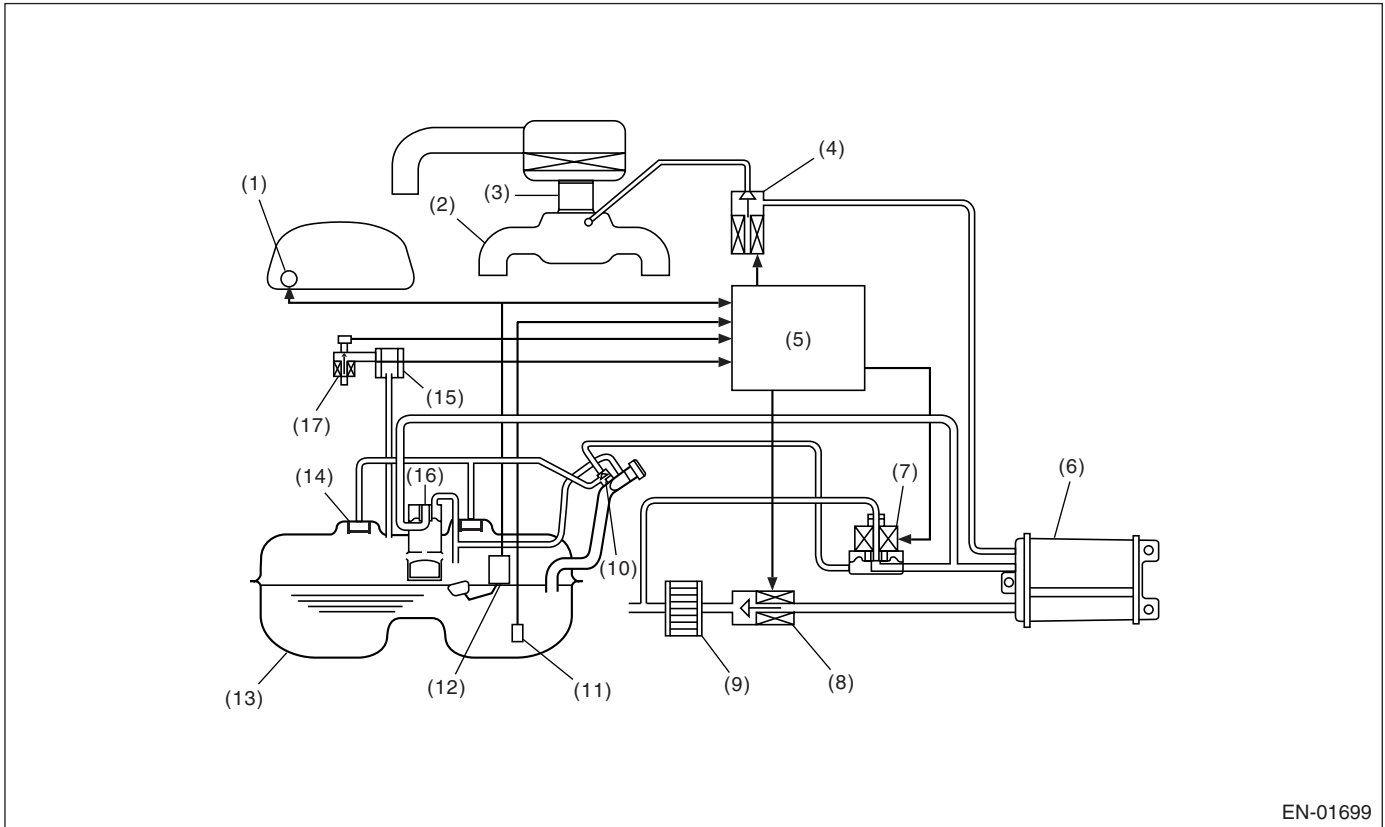

- |                                     |                                             |
|-------------------------------------|---------------------------------------------|
| (1) Fuel gauge                      | (10) Shut-off valve                         |
| (2) Intake manifold                 | (11) Fuel temperature sensor                |
| (3) Throttle body                   | (12) Fuel level sensor                      |
| (4) Purge control solenoid valve    | (13) Fuel tank                              |
| (5) Engine control module (ECM)     | (14) Fuel cut valve                         |
| (6) Canister                        | (15) Fuel tank pressure sensor              |
| (7) Pressure control solenoid valve | (16) Vent valve                             |
| (8) CCV                             | (17) Tank pressure switching solenoid valve |
| (9) Drain filter                    |                                             |

In this system diagnosis, checking for leakage and valve function is conducted by changing the fuel tank pressure, and monitoring the pressure change using the fuel tank pressure sensor. 0.04 inch diagnosis is performed in the order of mode Z, mode A, mode B, mode C, mode D and mode E, and 0.02 inch diagnosis is performed in the order of mode Y, mode A, mode B, mode C, mode D and mode E.

# DIAGNOSTIC TROUBLE CODE (DTC) DETECTING CRITERIA

GENERAL DESCRIPTION

## • 0.04-inch Diagnosis

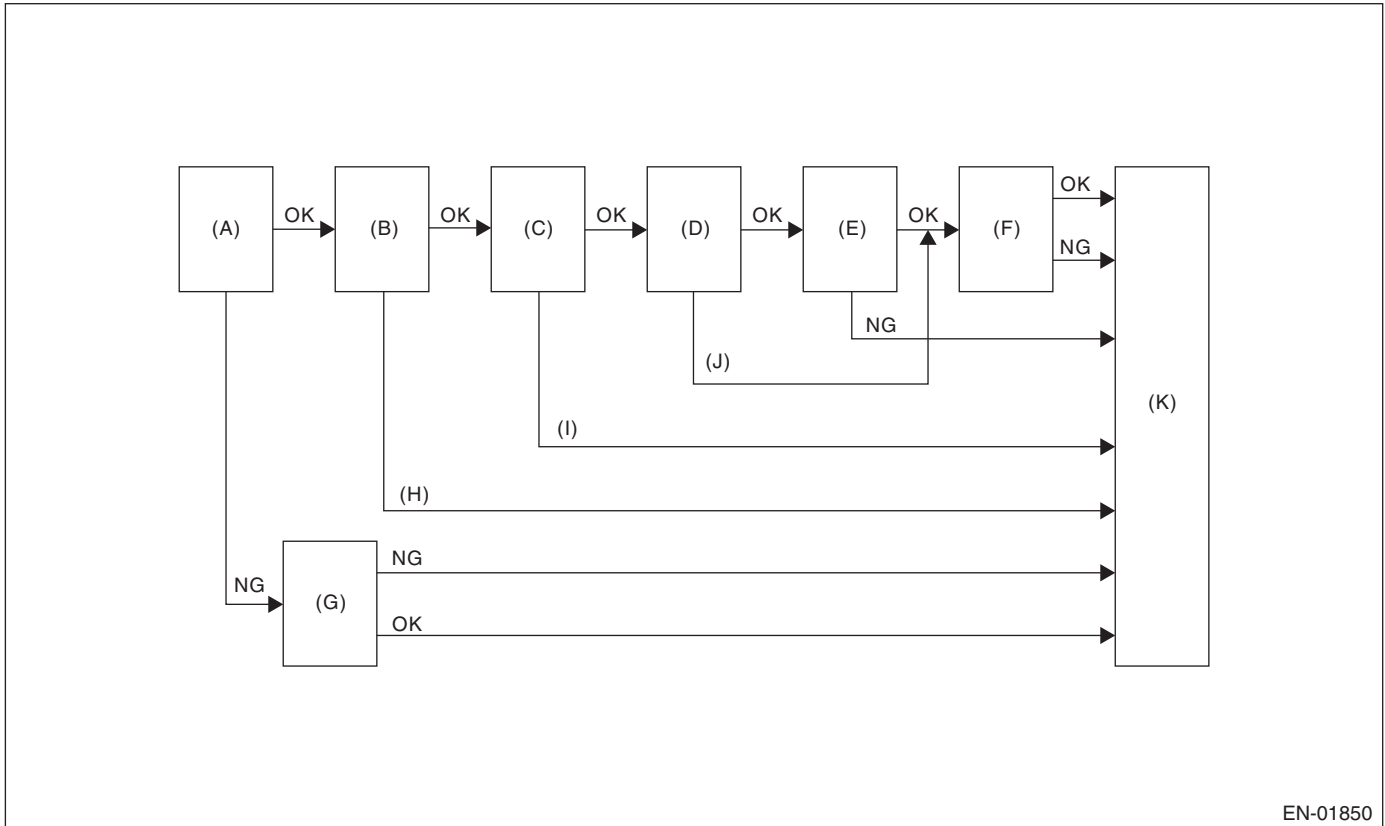

EN-01850

- |            |                             |
|------------|-----------------------------|
| (A) Mode Z | (G) Mode Z extend           |
| (B) Mode A | (H) Cancel                  |
| (C) Mode B | (I) Large leakage judgement |
| (D) Mode C | (J) Early OK                |
| (E) Mode D | (K) End                     |
| (F) Mode E |                             |

Mode	Mode Description	Diagnosis Period
Mode Z (CCV abnormal close diagnosis)	At starting a diagnosis, and carry out CCV close trouble diagnosis according to tank pressure change amount.	3 — 16 seconds
Mode A (Estimated evaporation amount)	Calculate the tank pressure change amount (P1).	7 — 15.5 seconds
Mode B (Sealed negative pressure, large leakage judgment)	Introduce the intake manifold pressure to the fuel tank and reduce the tank pressure to the desired value. If the tank pressure cannot be reduced, it is diagnosed as large leak.	5 — 35 seconds
Mode C (Pressure increase check, advanced OK judgment)	Wait until the tank pressure becomes P2 calculation start pressure. If the tank pressure does not become the value, make advanced OK judgment.	4 — 16 seconds
Mode D (Negative pressure variation measurement, evaporation leakage diagnosis)	Calculate the tank pressure variation (P2), and obtain the diagnostic value using P1 of Mode A. Perform the evaporation leakage diagnosis using the diagnostic value.	7 — 15.5 seconds
Mode E (CCV property abnormal diagnosis)	After the leakage diagnosis, CCV property abnormal diagnosis according to the tank pressure change amount.	4 seconds

# DIAGNOSTIC TROUBLE CODE (DTC) DETECTING CRITERIA

## GENERAL DESCRIPTION

### • 0.02-inch Diagnosis

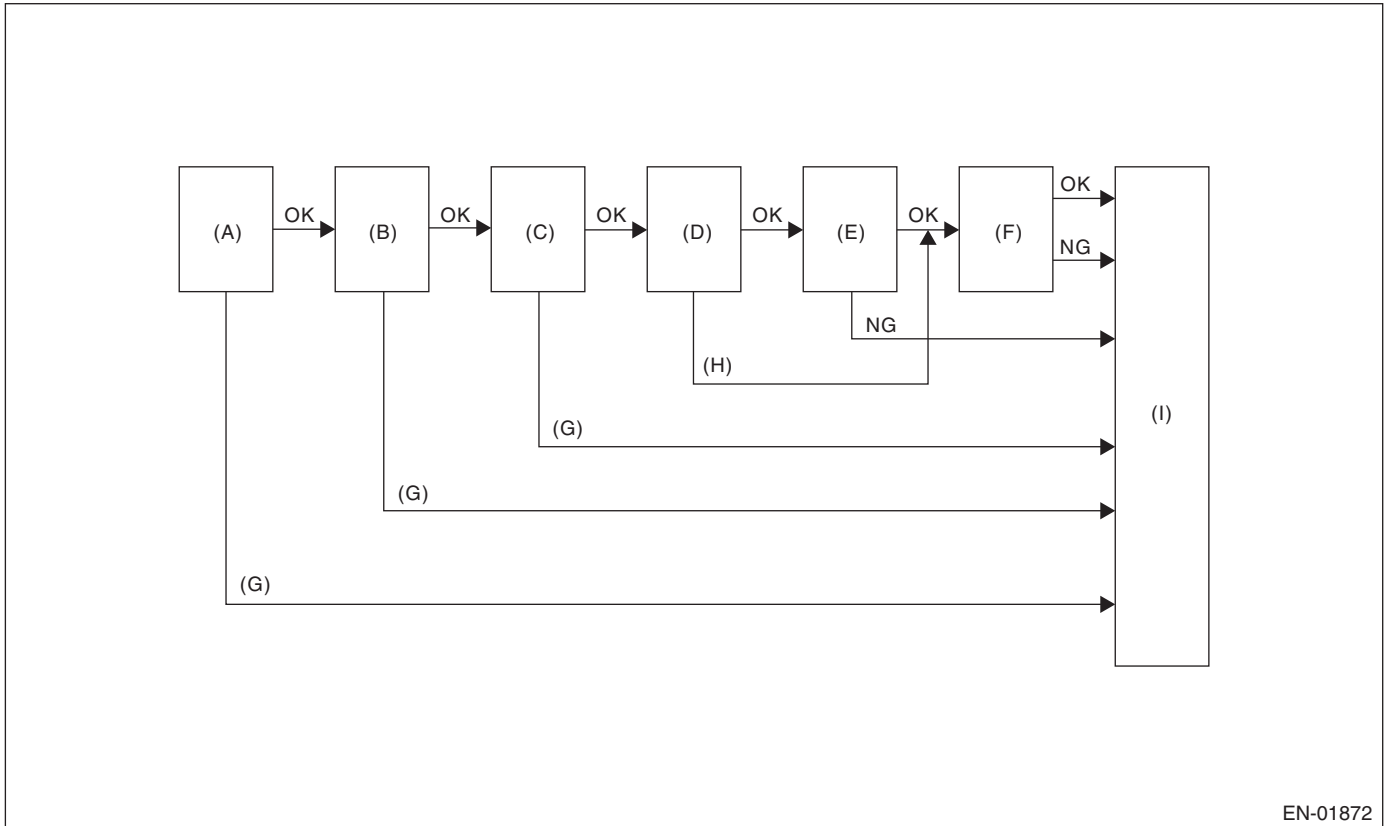

EN-01872

- |            |              |
|------------|--------------|
| (A) Mode Y | (F) Mode E   |
| (B) Mode A | (G) Cancel   |
| (C) Mode B | (H) Early OK |
| (D) Mode C | (I) End      |
| (E) Mode D |              |

Mode	Mode Description	Diagnosis Period
Mode Y (Tank pressure stabilization)	Return the tank pressure to atmosphere.	0.1 seconds
Mode A (Estimated evaporation amount)	Calculate the tank pressure change amount (P1).	18 — 29 seconds
Mode B (Negative pressure sealed)	Introduce the intake manifold pressure to the fuel tank and reduce the tank pressure to the desired value.	10 — 62 seconds
Mode C (Pressure increase check, advanced OK judgment)	Wait until the tank pressure becomes P2 calculation start pressure. If the tank pressure does not become the value, make advanced OK judgment.	5 — 20 seconds
Mode D (Negative pressure variation measurement, evaporation leakage diagnosis)	Calculate the tank pressure variation (P2), and obtain the diagnostic value using P1 of Mode A. Perform the evaporation leakage diagnosis using the diagnostic value.	14 — 25 seconds
Mode E (CCV property abnormal diagnosis)	After the leakage diagnosis, perform the CCV property abnormal diagnosis according to the tank pressure change amount.	4 seconds

# DIAGNOSTIC TROUBLE CODE (DTC) DETECTING CRITERIA

GENERAL DESCRIPTION

## • Mode Table for Evaporative Emission Control System Diagnosis

### 0.04-inch Diagnosis

Mode	Behavior of tank internal pressure under normal conditions	Diagnostic item	DTC
Mode Z	Nearly same as atmospheric pressure (equivalent pressure of 0 kPa (0 mmHg, 0 inHg))	CCV is judged to be stuck closed.	P1443
Mode A	Pressure is in proportion to amount of evaporation gas occurrence.		
Mode B	Negative pressure is formed due to intake manifold negative pressure	Large leakage judgment	P0457
Mode C	Target pressure is reached.		
Mode D	Pressure change is small.	Evaporation system is judged to have large leak [1.0 mm (0.04 in)].	P0442
Mode E	Return to atmosphere	CCV property judgment	P1443

### 0.02-inch Diagnosis

Mode	Behavior of tank internal pressure under normal conditions	Diagnostic item	DTC
Mode Y	Return to atmosphere		
Mode A	Pressure is in proportion to amount of evaporation gas occurrence.		
Mode B	Negative pressure is formed due to intake manifold negative pressure		
Mode C	Target pressure is reached.		
Mode D	Pressure change is small.	P2 measurement of small leak in system. Evaporation system is judged to have small leak [0.5 mm (0.02 in.)].	P0456
Mode E	Return to atmosphere	CCV property judgment	P1443

# DIAGNOSTIC TROUBLE CODE (DTC) DETECTING CRITERIA

## GENERAL DESCRIPTION

### 2. COMPONENT DESCRIPTION

#### • Pressure Control Solenoid Valve

PCV controls the fuel tank pressure to be equal to the atmospheric air pressure.

Normally, the solenoid is set to OFF. And the valve opens and closes mechanically in accordance with the pressure difference between tank and atmospheric air, or tank and canister.

The valve can be forcibly opened by setting the solenoid to ON at the time of diagnosis.

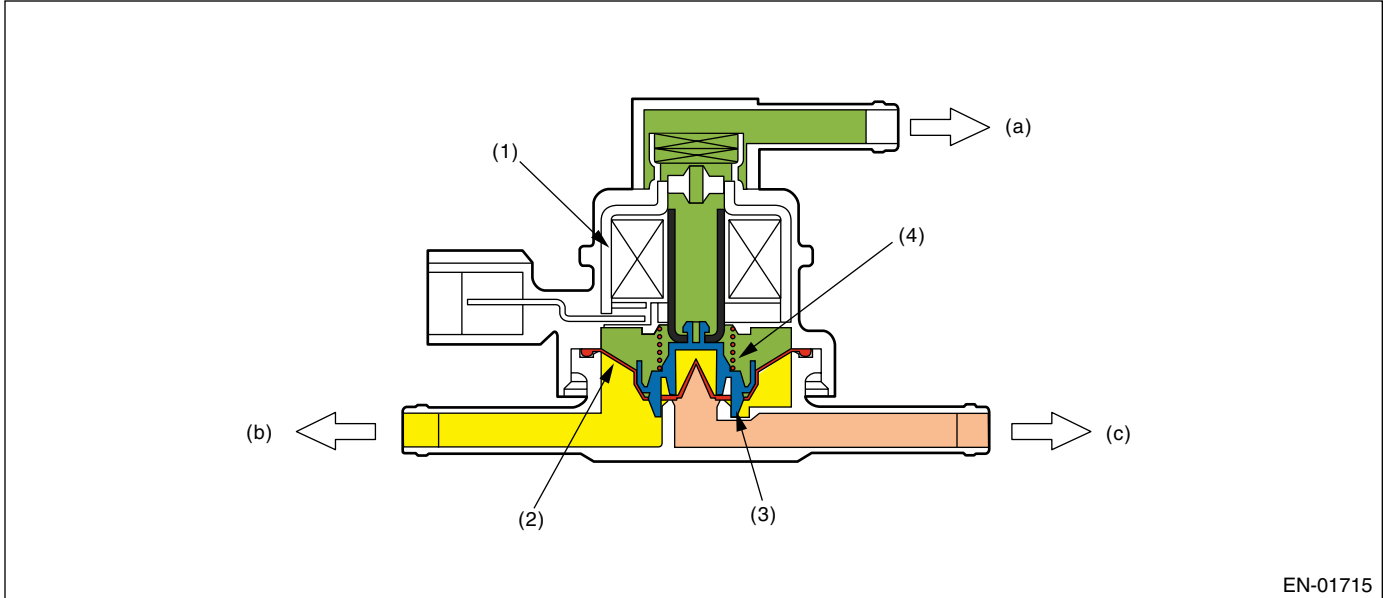

- (1) Solenoid
- (2) Diaphragm
- (3) Valve
- (4) Spring

- (a) Atmospheric pressure
- (b) Fuel tank
- (c) Canister

EN-01715

# DIAGNOSTIC TROUBLE CODE (DTC) DETECTING CRITERIA

GENERAL DESCRIPTION

## • Valve Operation and Air Flow

In the figure below, divided by the diaphragm, the part above X is charged with atmospheric air pressure, and the part below X is charged with tank pressure. Also, the part above Y is charged with tank pressure, and the part below Y is charged with canister pressure.

If the atmospheric air pressure port is A, tank pressure port is B, and canister pressure port is C, the air flows according to pressure difference from each port as shown in the table below.

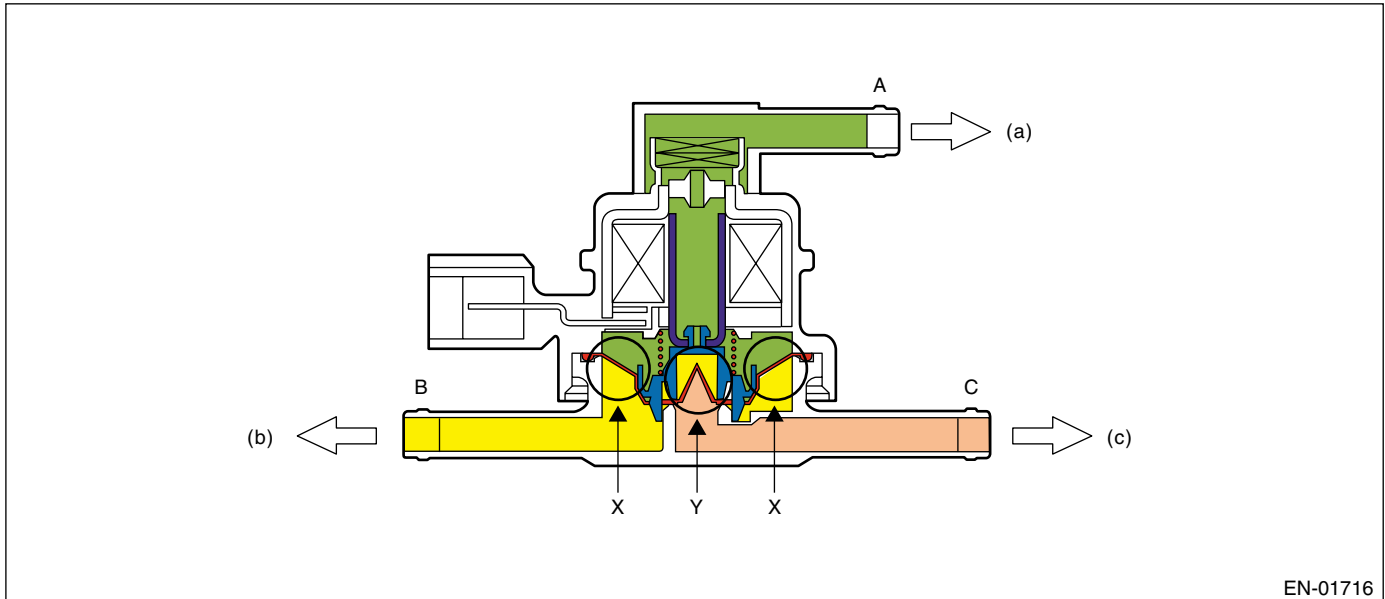

EN-01716

- (a) Atmospheric pressure
- (b) Fuel tank
- (c) Canister

Condition of pressure	Flow
$A < B$ (solenoid OFF)	$B \rightarrow C$
$B < C$ (solenoid OFF)	$C \rightarrow B$
Solenoid ON	$B \leftrightarrow C$

# DIAGNOSTIC TROUBLE CODE (DTC) DETECTING CRITERIA

## GENERAL DESCRIPTION

### • When $A < B$ (Solenoid OFF)

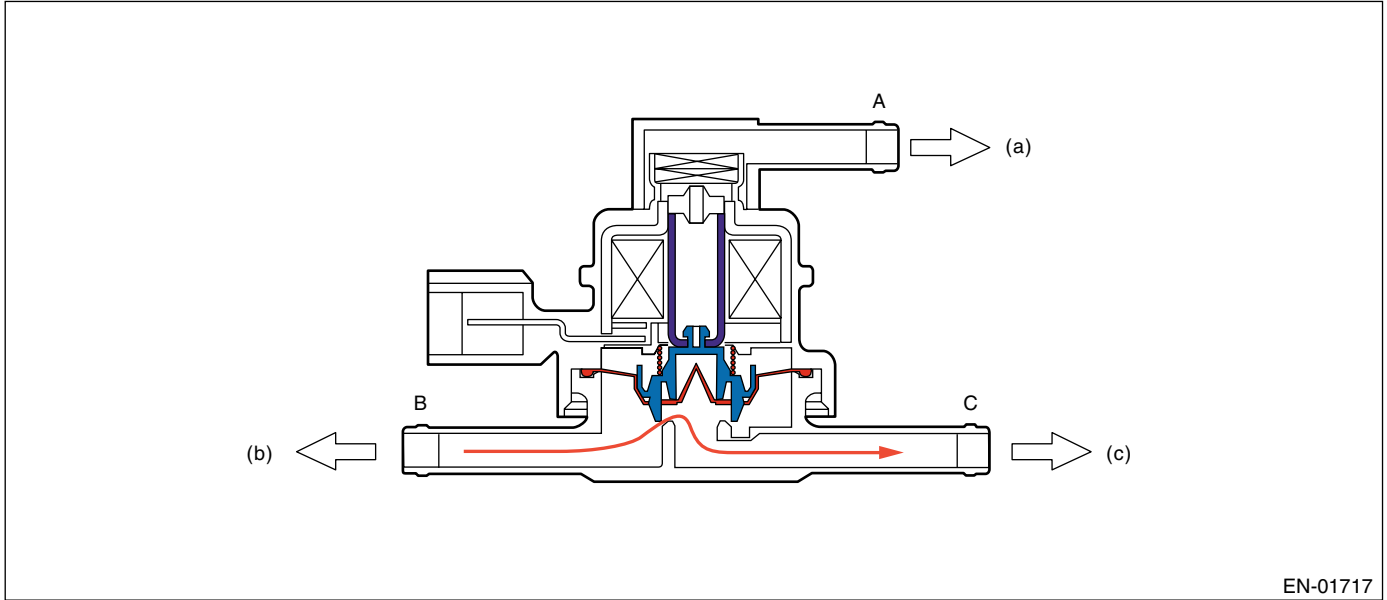

- (a) Atmospheric pressure
- (b) Fuel tank
- (c) Canister

### • When $B < C$ (Solenoid OFF)

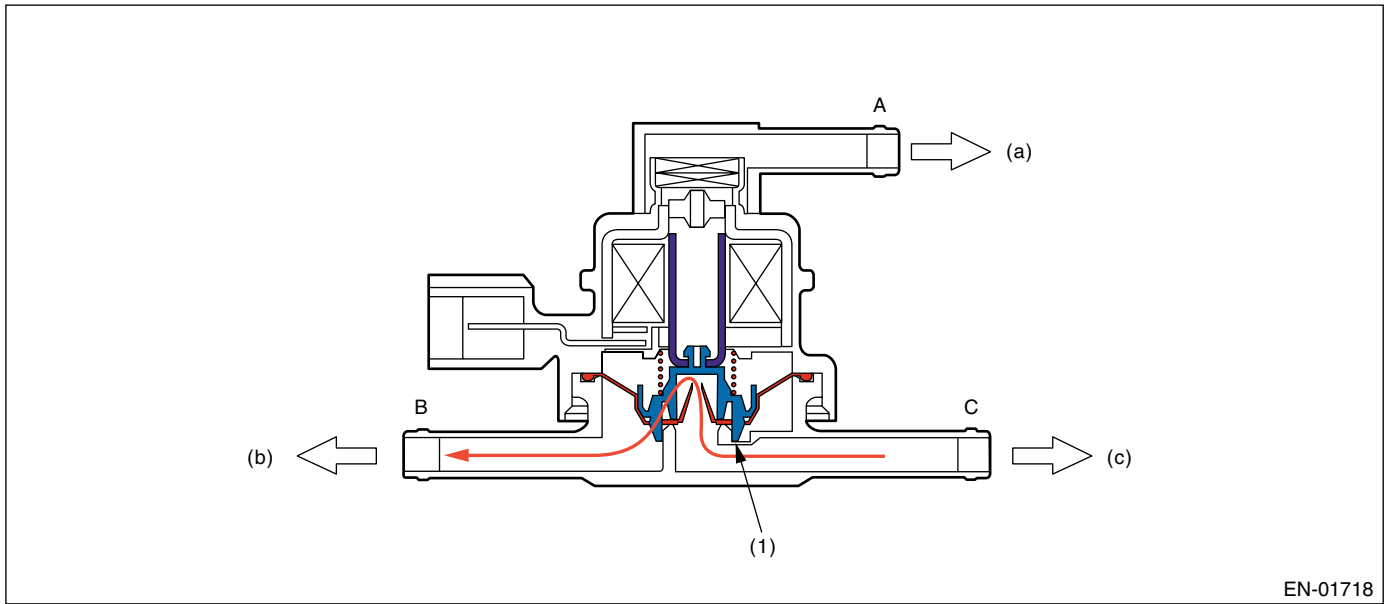

(1) Valve

- (a) Atmospheric pressure
- (b) Fuel tank
- (c) Canister



# DIAGNOSTIC TROUBLE CODE (DTC) DETECTING CRITERIA

GENERAL DESCRIPTION

- When Solenoid is ON

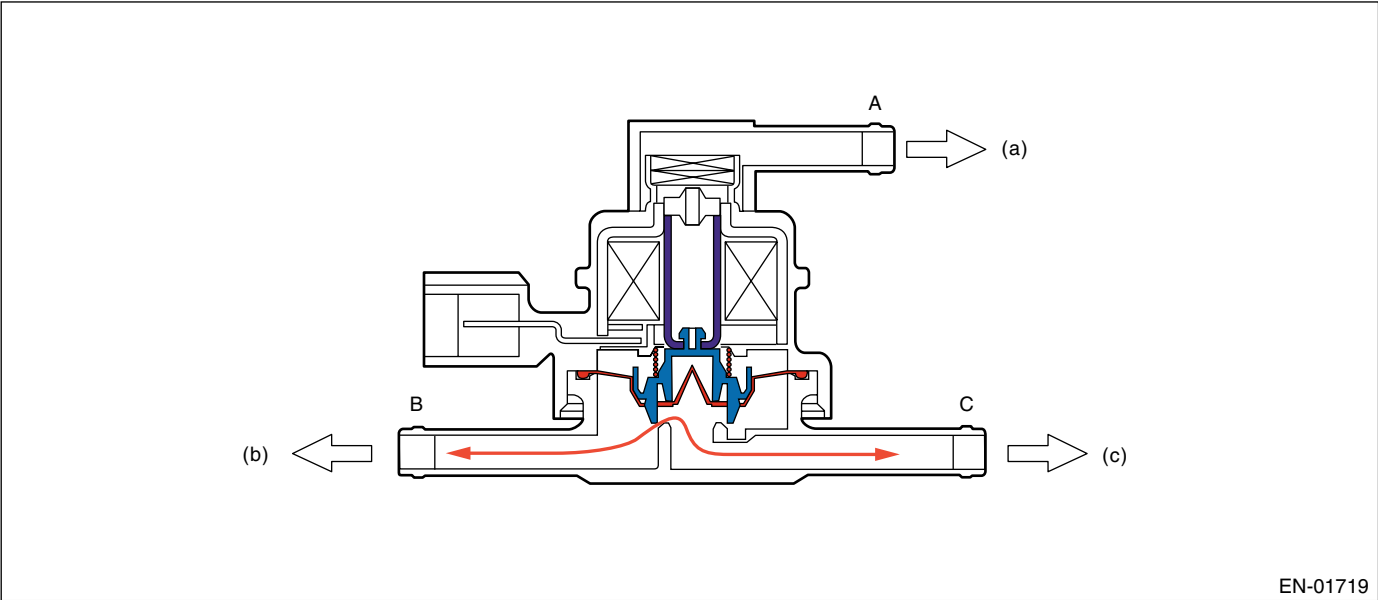

- (a) Atmospheric pressure
- (b) Fuel tank
- (c) Canister

# DIAGNOSTIC TROUBLE CODE (DTC) DETECTING CRITERIA

## GENERAL DESCRIPTION

### • CCV

CCV controls the ambient air to be introduced to the canister.

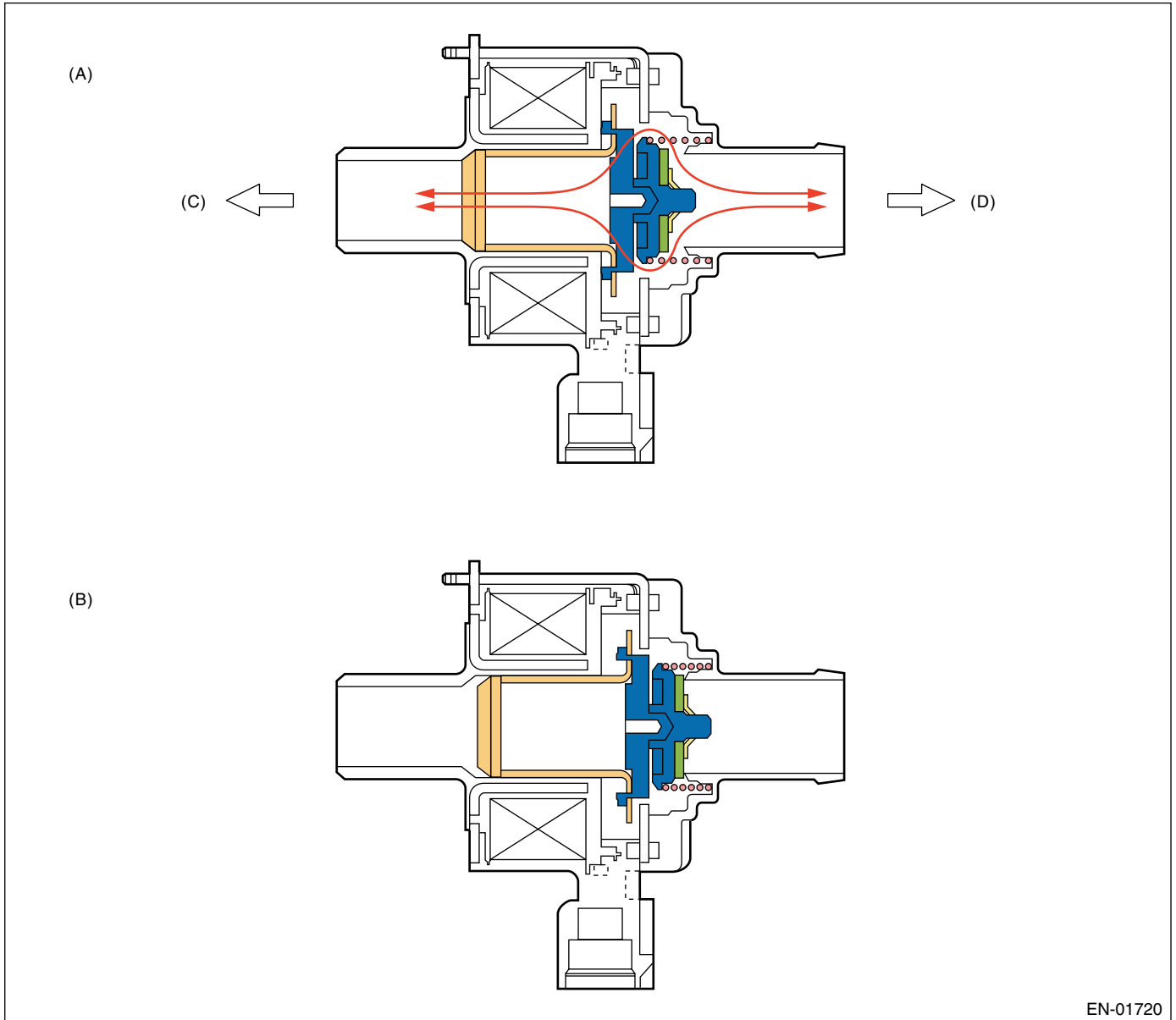

EN-01720

- (A) Open (Solenoid OFF)
- (B) Close (Solenoid ON)
- (C) Filter
- (D) Canister

# DIAGNOSTIC TROUBLE CODE (DTC) DETECTING CRITERIA

GENERAL DESCRIPTION

- Tank Pressure Switching Solenoid

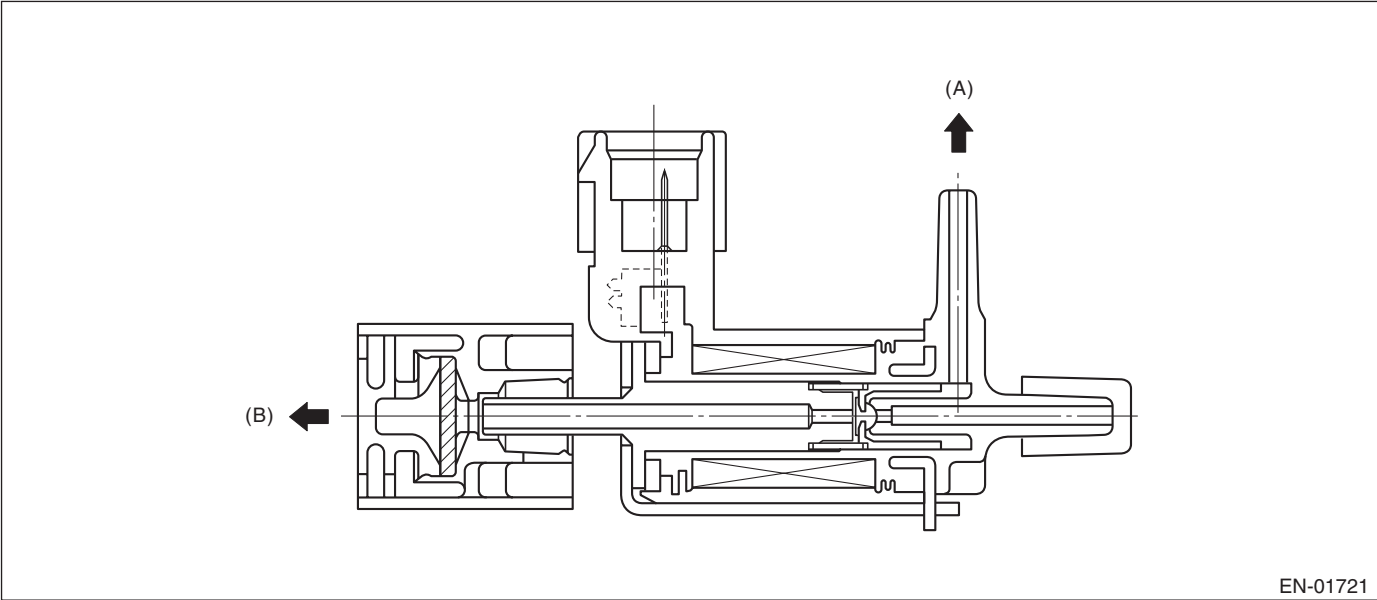

- (A) Fuel tank pressure sensor
- (B) Atmosphere

# DIAGNOSTIC TROUBLE CODE (DTC) DETECTING CRITERIA

## GENERAL DESCRIPTION

### • Purpose of this solenoid

Fuel tank pressure sensor detects the difference between the atmospheric air pressure and the tank pressure and the ECM monitors the pressure difference.

Even if the tank pressure is constant, the atmospheric air pressure varies depending on the driving height, and the pressure signal transmitted to ECM will change.

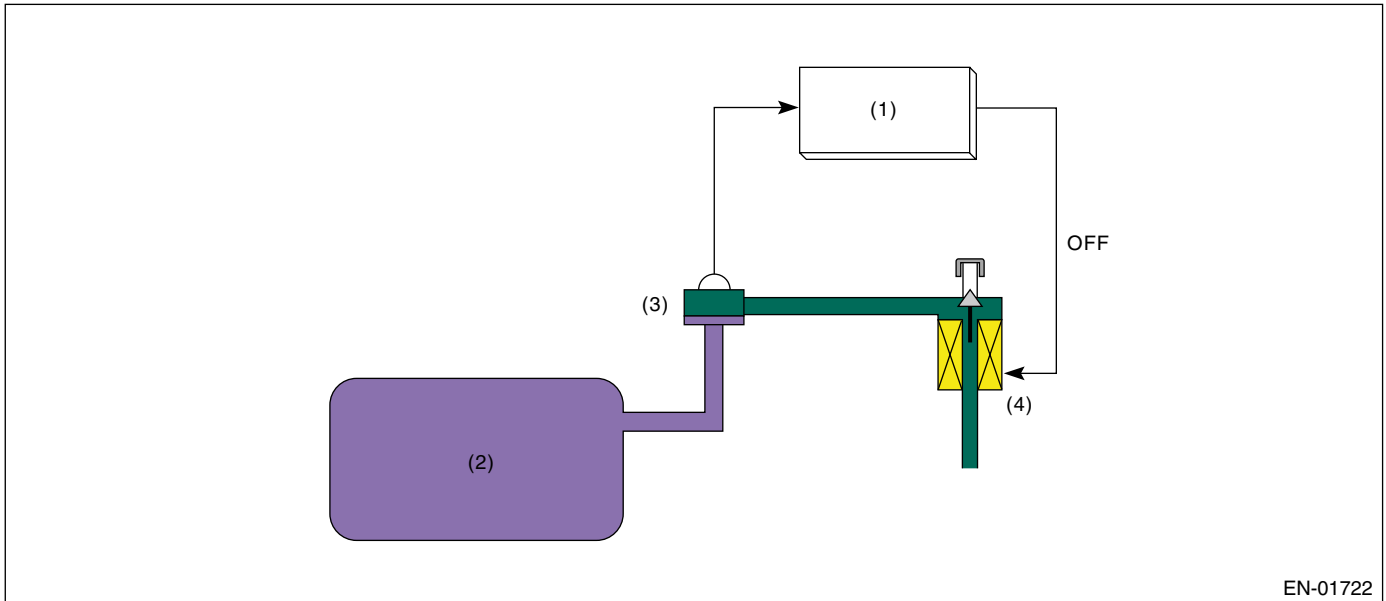

- (1) Engine control module (ECM)
- (2) Fuel tank
- (3) Fuel tank pressure sensor
- (4) Atmospheric pressure switching solenoid

EN-01722

# DIAGNOSTIC TROUBLE CODE (DTC) DETECTING CRITERIA

GENERAL DESCRIPTION

Especially, in the small leakage [0.5 mm (0.02 in)], minute change in the tank pressure has to be detected. This diagnosis period is long (approx. 29 seconds). And if the driving height changes during the diagnosis, the atmospheric air pressure changes. In this case, it becomes difficult to precisely detect the tank pressure variation, causing erroneous diagnosis. Therefore, using the atmospheric pressure switching solenoid, atmospheric air is sealed between the fuel tank pressure sensor and atmospheric pressure switching solenoid, maintaining the air pressure constant and enabling the detection of minute variation of tank pressure.

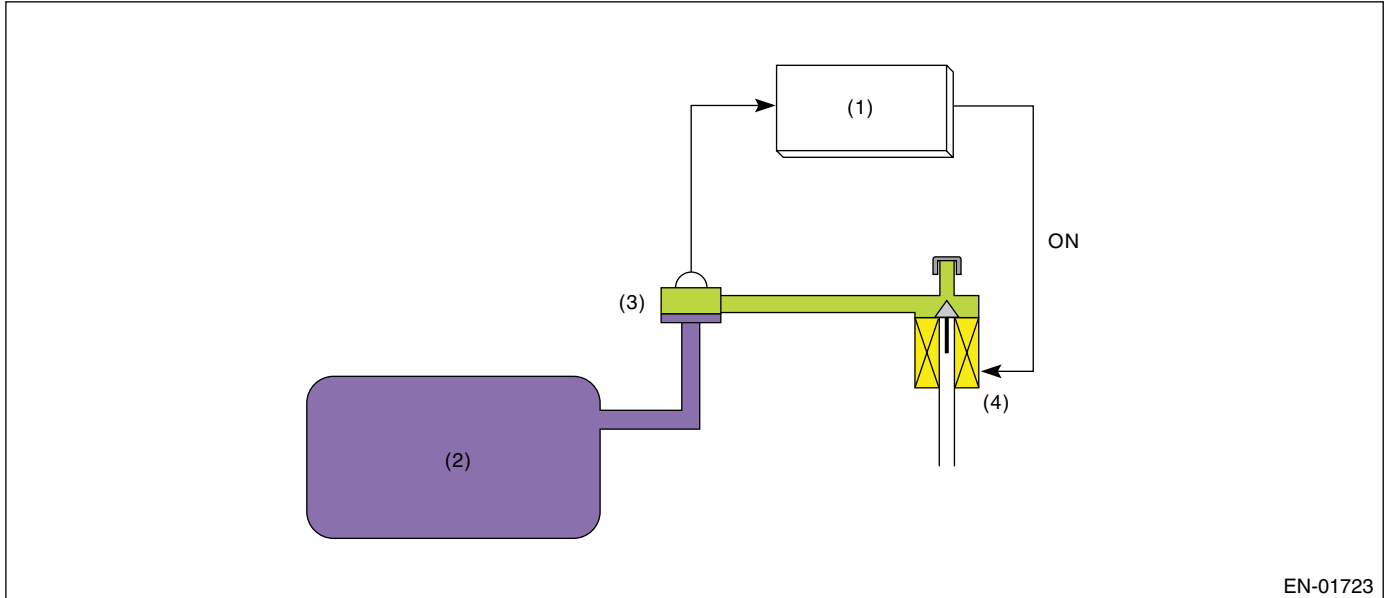

- (1) Engine control module (ECM)
- (2) Fuel tank
- (3) Fuel tank pressure sensor
- (4) Atmospheric pressure switching solenoid

## NOTE:

ECM also has the atmospheric air pressure sensor, and always monitors atmospheric air. However, as the monitoring range is large, that is, 53 to 107 kPa (400 to 800 mmHg, 16 to 32 inHg) it is not suitable for detection of minute pressure variation.

In the case of small leakage diagnosis, the tank pressure variation is very small, that is, 0.13 to 0.27 kPa (1 to 2 mmHg, 0.04 to 0.08 inHg) and the fuel tank pressure sensor is equipped.

# DIAGNOSTIC TROUBLE CODE (DTC) DETECTING CRITERIA

## GENERAL DESCRIPTION

### 3. ENABLE CONDITION

#### 0.04-inch Diagnosis

Secondary Parameters	Enable Conditions
Closed air/fuel ratio	In operation
Throttle angle	3.8 — 14.1°
Canister purge cumulative time	≥ 120 seconds
Engine speed	≥ 1500 rpm
Fuel tank pressure at Evap. monitoring starting	≥ -1000 — 1600 Pa (-7.5 — 12.0 mmHg, -0.295 — 0.472 inHg)
Intake manifold relative pressure	≥ -26.66 kPa (-200 mmHg, -7.9 inHg)
Vehicle speed	≥ 48 km/h (30 MPH)
Fuel level	9 — 51 ℓ (2.4 — 13.5 US gal, 2.0 — 11.2 Imp gal)
After engine started	More than 454 sec- onds
Barometric pressure	≥ 76 kPa (568 mmHg, 22.4 inHg)
Fuel temperature	-10 — 45°C (14 — 113°F)

#### Cancel Conditions

Secondary Parameters	Enable Conditions
Change of fuel level	≥ 5 ℓ (1.3 US gal, 1.1 Imp gal)/200 millise- conds
Throttle angle	≤ 0.640°
Engine speed	≤ 1300 rpm
Intake manifold relative pressure	≤ -16 kPa (-120 mmHg, 4.7 inHg)
Vehicle speed	≤ 48 km/h (30 MPH)
Compensation factor of air fuel ratio	≤ -30%
Tank pressure variation amount	≥ 0.1 kPa (0.75 mmHg, 0.03 inHg)
Difference between max. and min. pres- sure per second while monitoring	< 300 Pa (2.3 mmHg, 7.6 inHg)
Time after the completion of previous 0.04-inch leak diagnosis	> 180 seconds

# DIAGNOSTIC TROUBLE CODE (DTC) DETECTING CRITERIA

GENERAL DESCRIPTION

## 0.02-inch Diagnosis

Secondary Parameters	Enable Conditions
Continuous time when all conditions are completed.	≥ 5 seconds
Fuel tank pressure at vacuum starting	-37.5 — 937 Pa (-0.28 — 7.03 mmHg, -0.0110 — 10.7 inHg)
Time after the cancellation of 0.02-inch leak diagnosis	> 180 seconds
Total time of operating canister purge	More than 120 seconds
After engine started	More than 325 seconds
Fuel tank pressure below -3050 Pa (-22.87 mmHg, -0.9007 inHg) during same driving cycle	< 2 seconds
Fuel temperature	-10 — 35°C (14 — 95°F)
After engine start with coolant temperature of 40°C or below	< 2400 seconds
Fuel level	9 — 51 ℓ (2.4 — 13.5 US gal, 2.0 — 11.2 Imp gal)
Atmospheric pressure	≥ 75.7 kPa (568 mmHg, 22.3 inHg)
Ambient temperature	≥ -10°C (14°F)
(Ambient-fuel) temperature	≥ 1°C (1.8°F)
Closed air fuel ratio control	In operating

# DIAGNOSTIC TROUBLE CODE (DTC) DETECTING CRITERIA

## GENERAL DESCRIPTION

### Cancel Conditions

Secondary Parameters	Enable Conditions
Lambda element	< 0.75 kPa (5.62 mmHg, 0.22 inHg)
P1	≥ 125 Pa (0.94 mmHg, 0.04 inHg)
P1	≥ -87.5 Pa (-0.66 mmHg, -0.03 inHg)
Fuel level variation	≥ 5 ℓ (1.32 US gal, 1.10 Imp gal)
Engine speed	< 1500 rpm
Manifold pressure - atmospheric pressure	> -9.07 kPa (-68 mmHg, -2.68 inHg)
Vehicle speed	> 68 km/h (42 MPH)
Comparison between fuel tank pressure variation per second and that of previous second	≥ 100 Pa (0.75 mmHg, 0.03 inHg)
Difference between max. and min. pressures of fuel tank per second while monitoring	≥ 300 Pa (2.25 mmHg, 0.09 inHg)
Atmospheric pressure variation while calculating P1	≥ 150 Pa (1.13 mmHg, 0.05 inHg)
Atmospheric pressure variation while calculating P1	≥ 150 Pa (1.13 mmHg, 0.05 inHg)
Fuel level variation after engine starting (8 ℓ (2.11 US gal, 1.76 Imp gal) or more)	≤ 3 times
Engine speed variation after diagnosis starting	≥ 300 rpm
Manifold pressure variation after diagnosis starting	≥ 20.0 kPa (150 mmHg, 5.91 inHg)

## 4. GENERAL DRIVING CYCLE

### • 0.04-inch Diagnosis

- Perform the diagnosis only once in more than 920 seconds after the engine start at the constant driving speed of 48 km/h (30 MPH) or more.
- Pay attention to the fuel temperature and fuel level.

### • 0.02-inch Diagnosis

- Perform diagnosis in more than 325 seconds after engine start at the constant speed of 68 km/h (42 MPH) or more, and then terminate the diagnosis when judged OK or NG.
- If not judged OK or NG, repeat the diagnosis until judged OK or NG.
- Pay attention to the fuel temperature and fuel level.



# DIAGNOSTIC TROUBLE CODE (DTC) DETECTING CRITERIA

GENERAL DESCRIPTION

## 5. DIAGNOSTIC METHOD

### • MODE Y (Tank pressure stabilization)

Perform the diagnosis under the conditions, and return the tank pressure to atmosphere.

Tank pressure > 0.9 kPa (67.5 mmHg, 2.7 inHg) after 0.1 seconds:

Cancel the leak check. (Change to Mode A, Tank pressure ≤ 0.9 kPa (67.5 mmHg, 2.7 inHg).)

### • MODE Z (Purge control solenoid valve open malfunction diagnosis, CPC close malfunction diagnosis)

DTC P0457

DTC P1443

### • Purpose of Mode Z

When performing the leakage diagnosis of EVAP system, CCV and CPC have to operate normally. Therefore, mode Z is used to diagnose the CCV close fixation and CPC open fixation.

If the CCV closed fixation trouble or CPC open fixation trouble is detected, the EVAP system leakage diagnosis is cancelled.

If the CCV closed fixation trouble occurred, negative pressure is generated from the engine to pressure control solenoid valve when pressure control solenoid valve is closed and CPC is opened. In this case, the valve cannot be opened for the pressure control solenoid valve structure if the negative pressure is larger than electromagnetic force when pressure control solenoid valve solenoid is set to ON in order to open the valve.

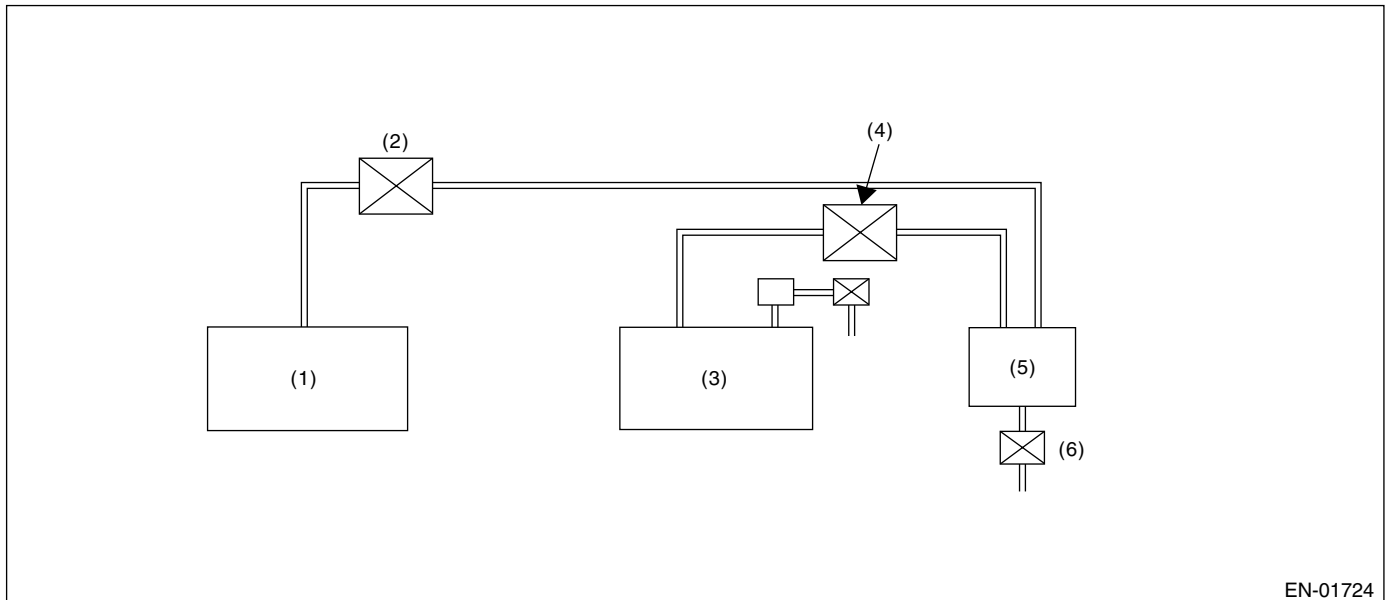

EN-01724

(1) Engine

(2) Purge control solenoid valve open

(3) Fuel tank

(4) Pressure control solenoid valve close

(5) Canister

(6) CCV stuck close

# DIAGNOSTIC TROUBLE CODE (DTC) DETECTING CRITERIA

## GENERAL DESCRIPTION

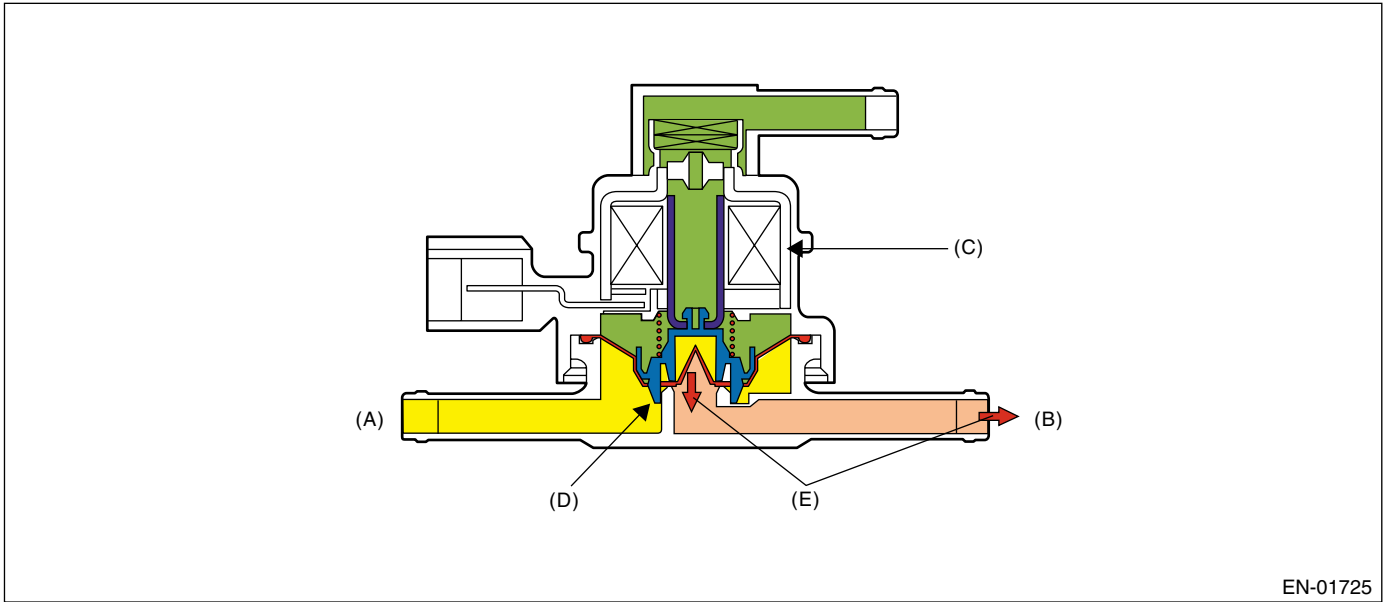

EN-01725

- (A) To fuel tank
- (B) To canister (Negative pressure)
- (C) Solenoid ON
- (D) Valve cannot be open.
- (E) Negative pressure

### • Diagnostic method

CCV closed fixation diagnosis and CPC open fixation diagnosis are performed in mode Z as shown in the figure below.

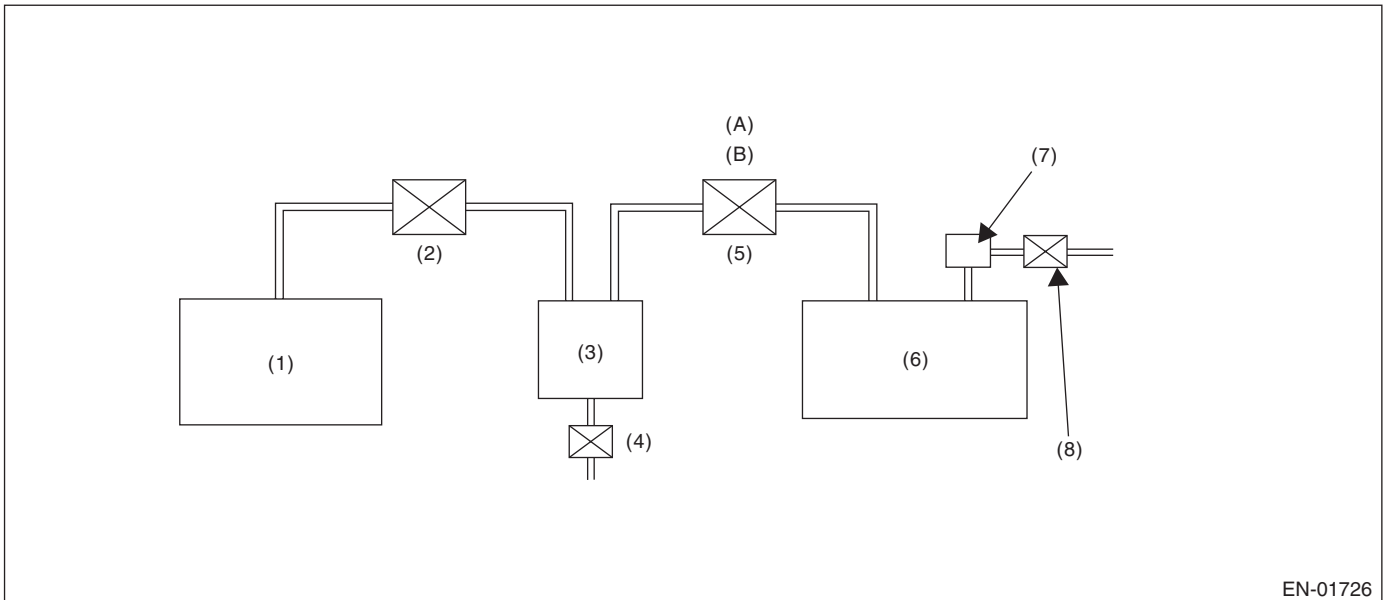

EN-01726

- |                                     |                                             |
|-------------------------------------|---------------------------------------------|
| (1) Engine                          | (6) Fuel tank                               |
| (2) Purge control solenoid valve    | (7) Fuel tank pressure sensor               |
| (3) Canister                        | (8) Tank pressure switching solenoid valve  |
| (4) Drain valve                     | (A) Normal condition: mechanical control    |
| (5) Pressure control solenoid valve | (B) Under the diagnosis: electronic control |

# DIAGNOSTIC TROUBLE CODE (DTC) DETECTING CRITERIA

GENERAL DESCRIPTION

## • Normal Operation

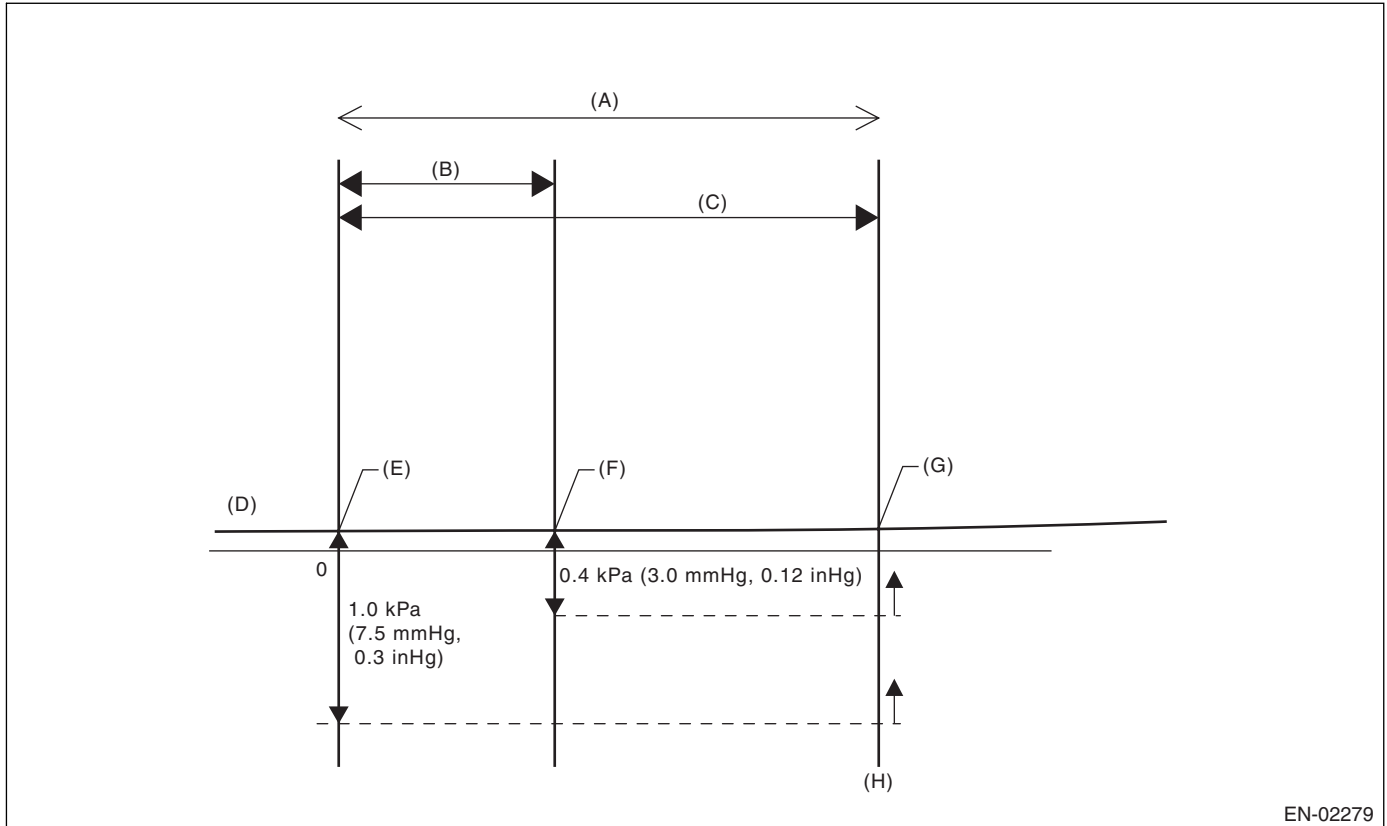

- (A) Mode Z
- (B) 1 s
- (C) 3 s
- (D) Fuel tank pressure
- (E) evptezini
- (F) evptez
- (G) evptezna
- (H) OK

- $evptez - evptezha \leq 0.4 \text{ kPa (3.0 mmHg, 0.12 inHg)}$
  - $evptezini - evptezha \leq 1.0 \text{ kPa (7.5 mmHg, 0.3 inHg)}$
- Judge normal when these calculations are completed.

# DIAGNOSTIC TROUBLE CODE (DTC) DETECTING CRITERIA

## GENERAL DESCRIPTION

### • Drain valve close fixation

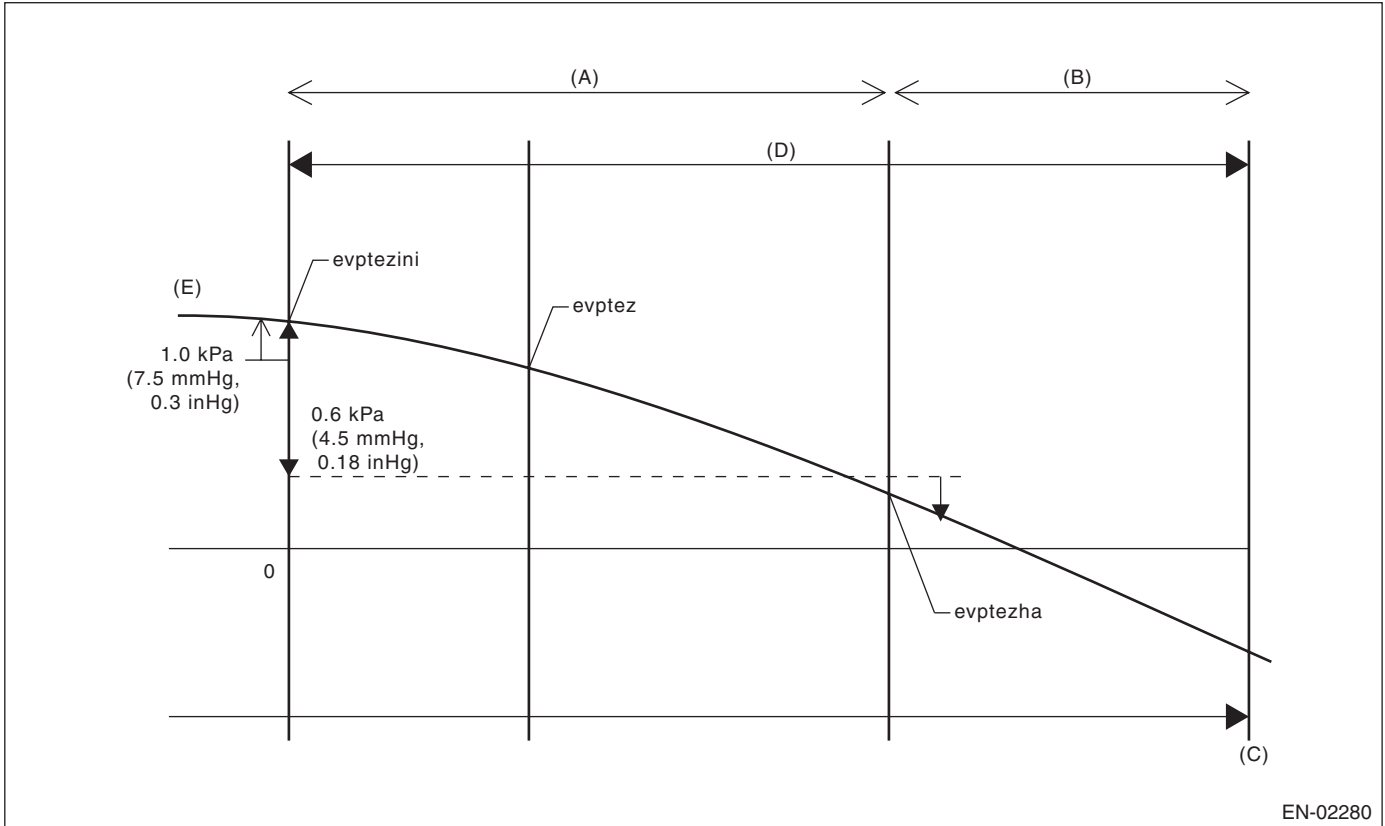

- (A) Mode Z
- (B) Mode Z extend
- (C) NG judgement
- (D) 16 s
- (E) Fuel tank pressure

- $evptezini - evptezha > 0.6 \text{ kPa (4.5 mmHg, 0.18 inHg)}$
- $evptezini > 1.0 \text{ kPa (7.5 mmHg, 0.3 inHg)}$

Judge normal when these calculations are completed.

### • Diagnosing Function of CCV [P1443]

CCV functional diagnosis is performed by monitoring the tank pressure variation in Mode Z.

#### Normality Judgment

Judge OK and change to Mode A when the criteria below are completed in 3 seconds after Mode Z started.

#### Judgment Value

Malfunction Criteria	Threshold Value	DTC
(Tank pressure 1 second after Mode Z starting) – (Tank pressure when Mode Z finished)	$\leq 0.4 \text{ kPa (3.0 mmHg, 0.12 inHg)}$	P1443
(Tank pressure when Mode Z started) – (Tank pressure when Mode Z finished)	$\leq 1.0 \text{ kPa (7.5 mmHg, 0.3 inHg)}$	

#### Abnormality Judgment

If OK judgment cannot be made, extend Mode Z 16 seconds more, and judge NG when all the criteria below are completed in 16 seconds.

# DIAGNOSTIC TROUBLE CODE (DTC) DETECTING CRITERIA

GENERAL DESCRIPTION

## Judgment Value

Malfunction Criteria	Threshold Value	DTC
Tank pressure when Mode Z started	> 1.0 kPa (7.5 mmHg, -0.3 inHg)	P1443
(Tank pressure when Mode Z started) – (Tank pressure when Mode Z finished)	> 0.6 kPa (4.5 mmHg, 0.18 inHg)	

**Time Needed for Diagnosis:** 16 seconds

**Malfunction Indicator Light Illumination:** Illuminates when malfunction occurs in 2 continuous driving cycles.

Finish the evaporative emission control system diagnosis when making NG judgment for drain valve close fixation.

Cancel the evaporative emission control system diagnosis when the OK/NG judgment for drain valve close fixation and purge control solenoid valve open fixation cannot be made in Mode Z.

### • Leak Diagnosis

DTC P0442

DTC P0456

DTC P0457

### • Diagnostic method

- The diagnostic method consists of creating a sealed vacuum in the fuel tank and then determining the presence of leakage from the speed at which the tank internal pressure returns to atmospheric pressure.
- The diagnosis is divided into the following five phases.

#### Mode A;

Calculate the tank pressure variation amount P1. After calculating P1, change to Mode B.

#### Mode B;

Introduce the negative pressure in the intake manifold to the tank.

Approx. 0 → -1.4 kPa (0 → -10.5 mmHg, 0 → -0.41 inHg) (0.04-in diagnosis)

Approx. 0 → -3.05 kPa (0 → -22.9 mmHg, 0 → -0.9 inHg) (0.02-in diagnosis)

When the pressure above (desired negative pressure) is reached, Mode C is entered.

In this case, if the tank pressure does not become the desired negative pressure, judge that there is a large leakage in the system.

Judge NG when the malfunction criteria below is completed.

Finish the Evap. diagnosis when judging large leak (35 seconds) in 0.04-inch diagnosis. Cancel the diagnosis (62 seconds) in 0.02-inch diagnosis.

### Abnormality Judgment

Judge NG (large leak) when the criteria below are completed in the specified time.

Specified Time

High vehicle speed mode (Vehicle speed ≥ 72 km/h (45 MPH)); 35 seconds

Low vehicle speed mode (Vehicle speed < 72 km/h (45 MPH)); 35 seconds

## Judgment Value

Malfunction Criteria	Threshold Value	DTC
(0.04-inch diagnosis) (Tank pressure when Mode Z started) – (Min. value of tank pressure during Mode B)	< 900 Pa (6.75 mmHg, 0.25 inHg)	P0457

Cancel the diagnosis when the NG judgment does not completed in the specified time.

# DIAGNOSTIC TROUBLE CODE (DTC) DETECTING CRITERIA

## GENERAL DESCRIPTION

### Mode C;

Stop the introduction of negative pressure. (Wait until the tank pressure returns to the start level of P2 calculation.)

Change to Mode D when the tank pressure returns to the start level of P2 calculation.

Judge immediate OK and change to Mode E when it does not return in spite of spending the specified time.

	Tank pressure when P2 calculation started	Time for immediate OK judgment
0.04-inch diagnosis	-1.3 kPa (-9.75 mmHg, -0.38 inHg)	16 seconds
0.02-inch diagnosis	-3 kPa (-22.5 mmHg, -0.89 inHg)	20 seconds

### Mode D;

Monitor the pressure variation in the tank in Mode D. In this case, the tank pressure increases, that is, the pressure becomes as high as the atmospheric air pressure, because evaporator is generated. However, if any leakage exists, the pressure increases additionally in proportion to this leakage. The pressure variation of this tank is P2.

After calculating P2, perform small leak diagnosis and change to Mode E if normal. Complete Evap. diagnosis if abnormal.

#### • After Diagnosis

Assigning P1 and P2, which are tank variations measured in Mode A and Mode B, to the formula below, judge the small leakage of the system. If the measured judgment value exceeds the threshold value, it is judged to be malfunction.

#### • 0.04-inch Diagnosis

#### Abnormality Judgment

Judge NG when the criteria below are completed and judge OK when not completed.

#### Judgment Value

Malfunction Criteria	Threshold Value	DTC
$P2 - 1.5 \times P1$  P2 = Tank pressure varying at a specified time in mode D. P1 = Tank pressure varying at a specified time in mode A.	> 0.55 kPa (4.13 mmHg, 0.16 inHg)	P0442

\*1.5: Compensation value of the amount of evaporator occurrence. (Because evaporator increases more when becoming negative pressure.)

#### • 0.02-inch Diagnosis

#### Abnormality Judgment

Judge NG when the criteria below are completed.

#### Judgment Value

Malfunction Criteria	Threshold Value	DTC
$P2 - 1.5 \times P1$  P2 = Tank pressure varying at a specified time in mode D. P1 = Tank pressure varying at a specified time in mode A.	$\geq 800$ Pa (6.0 mmHg, 0.24 inHg)	P0456

#### Normality Judgment

Judge OK when the criteria below are completed.

#### Judgment Value

Malfunction Criteria	Threshold Value	DTC
$P2 - 1.5 \times P1$	< 600 Pa (4.5 mmHg, 0.18 inHg)	P0456

# DIAGNOSTIC TROUBLE CODE (DTC) DETECTING CRITERIA

GENERAL DESCRIPTION

If not judged OK or NG, repeat the diagnosis.

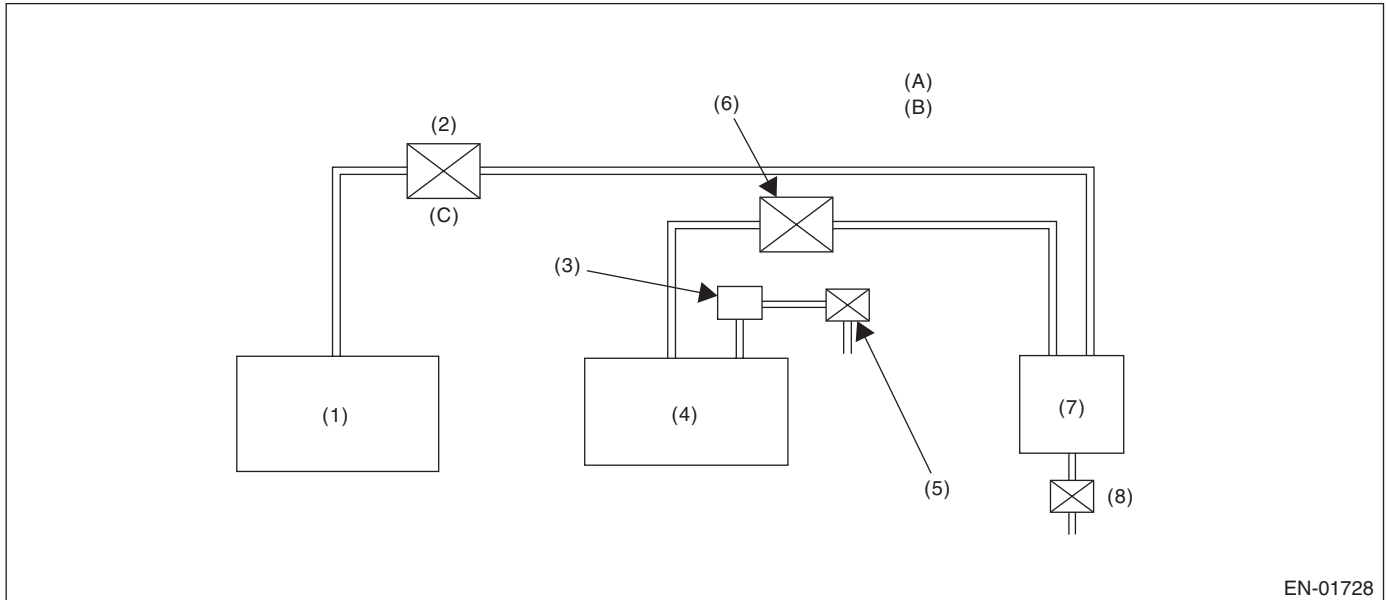

EN-01728

- |                                             |                                             |
|---------------------------------------------|---------------------------------------------|
| (1) Engine                                  | (7) Canister                                |
| (2) Purge control solenoid valve            | (8) Drain valve                             |
| (3) Fuel tank pressure sensor               | (A) Normal condition: mechanical control    |
| (4) Fuel tank                               | (B) Under the diagnosis: electronic control |
| (5) Atmospheric pressure switching solenoid | (C) Duty control                            |
| (6) Pressure control solenoid valve         |                                             |

# DIAGNOSTIC TROUBLE CODE (DTC) DETECTING CRITERIA

## GENERAL DESCRIPTION

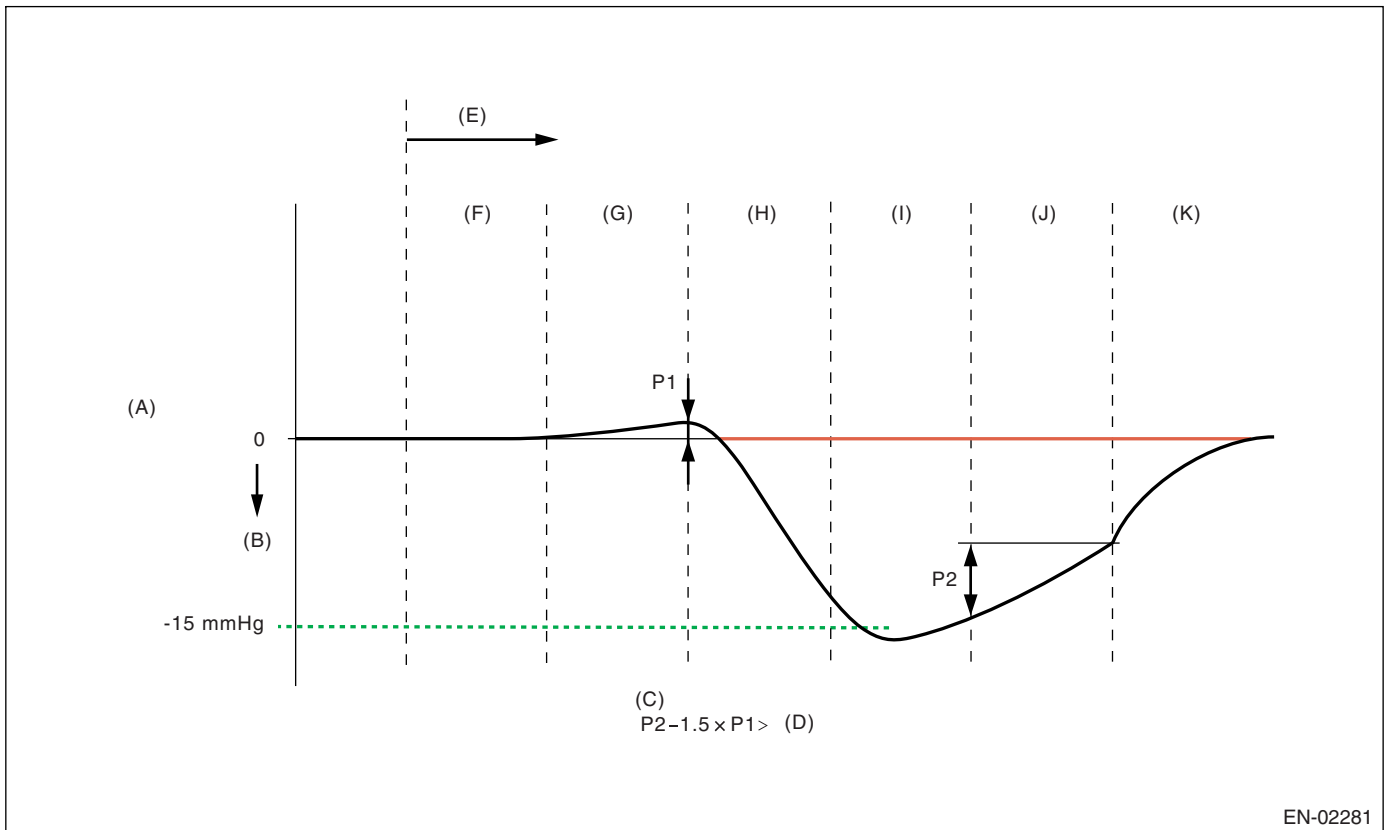

EN-02281

- (A) Fuel tank internal pressure
- (B) Negative pressure
- (C) Small leakage
- (D) Threshold value
- (E) Diagnosis start
- (F) Mode Z

- (G) Mode A
- (H) Mode B
- (I) Mode C
- (J) Mode D
- (K) Mode E



# DIAGNOSTIC TROUBLE CODE (DTC) DETECTING CRITERIA

GENERAL DESCRIPTION

## • CCV Property Diagnosis [P1443]

### Mode E;

The tank pressure must become again as high as the atmospheric air pressure, because the closed CCV becomes open after the evaporation diagnosis. If the tank pressure does not become as high as the atmospheric air pressure, judge that CCV is blocked.

Malfunction Criteria	Threshold Value	DTC
Fuel tank pressure difference from the end of EVAP sys. diagnosis to 4 seconds later	< 400 Pa (3.0 mmHg, 0.12 inHg)	P1443

### Time Needed for Diagnosis:

- 0.04-inch: 30 — 70 seconds
- 0.02-inch: 45 — 90 seconds

**Malfunction Indicator Light Illumination:** Illuminates when malfunction occurs in 2 continuous driving cycles.

## 6. DTC CLEAR CONDITION

- When the OK idling cycle was completed 40 times in a row
- When “Clear Memory” was performed

## 7. MALFUNCTION INDICATOR LIGHT CLEAR CONDITION

- When the OK driving cycle was completed 3 times in a row
- When “Clear Memory” was performed

## 8. FAIL SAFE

Atmospheric purge solenoid function malfunction; Open the pressure control solenoid valve.

## 9. ECM OPERATION AT DTC SETTING

- Memorize the freeze frame data. (For test mode \$02)
- Memorize the diagnostic value and trouble standard value. (For test mode \$06)

# DIAGNOSTIC TROUBLE CODE (DTC) DETECTING CRITERIA

## GENERAL DESCRIPTION

### AW:DTC P0447 — EVAPORATIVE EMISSION CONTROL SYSTEM VENT CONTROL CIRCUIT OPEN —

#### 1. OUTLINE OF DIAGNOSIS

Detect the open or short circuit of drain valve.

Judge NG when the ECM output level is not equal to the actual terminal level.

#### 2. COMPONENT DESCRIPTION

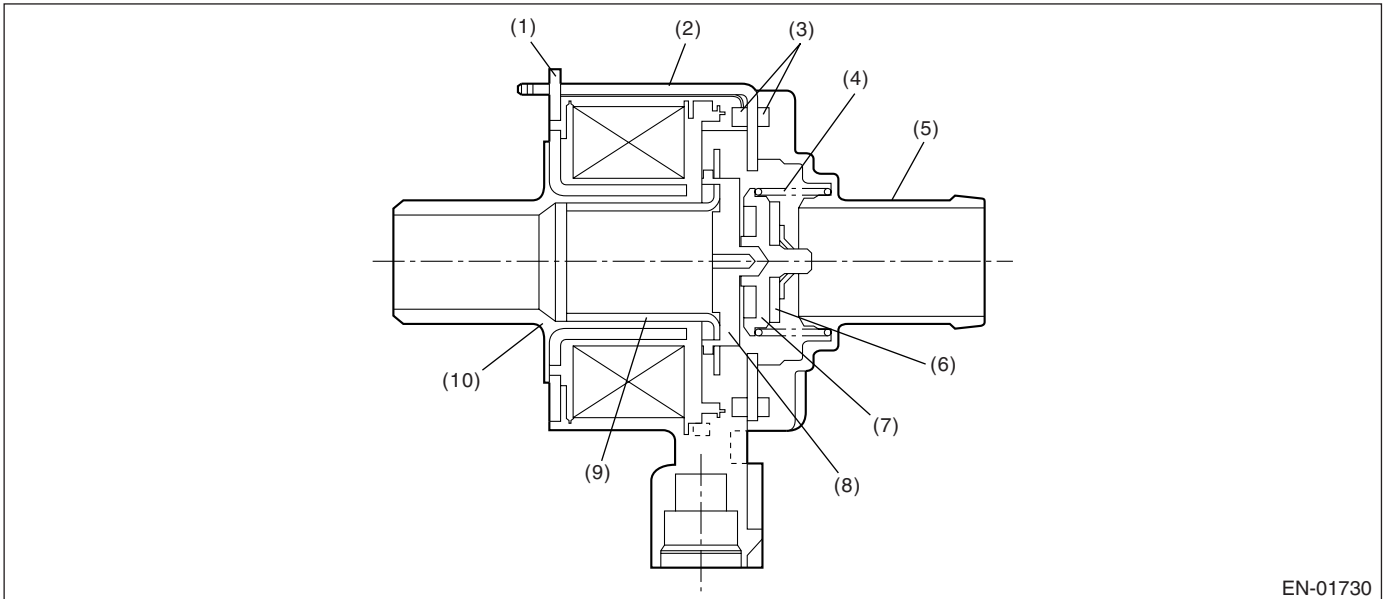

- (1) Magnetic plate
- (2) Yoke
- (3) Packing
- (4) Spring
- (5) Valve seat

- (6) Valve
- (7) Plate
- (8) Retainer
- (9) Movable core
- (10) Bobbin

#### 3. ENABLE CONDITION

Secondary Parameter	Enable Condition
Engine speed	$\geq 500$ rpm
Battery voltage	$\geq 8$ V
After starting the engine	1 second or more
Ignition switch	ON

#### 4. GENERAL DRIVING CYCLE

Perform the diagnosis continuously after string the engine.

# DIAGNOSTIC TROUBLE CODE (DTC) DETECTING CRITERIA

GENERAL DESCRIPTION

## 5. DIAGNOSTIC METHOD

### • Abnormality Judgment

Judge NG when the continuous time until completing the malfunction criteria below become more than time (2.5 seconds) needed for diagnosis.

### Judgment Value

Malfunction Criteria	Threshold Value
Terminal voltage when ECM outputs OFF signal.	Low

**Time Needed for Diagnosis:** 2.5 seconds

**Malfunction Indicator Light Illumination:** Illuminates when malfunction occurs in 2 continuous driving cycles.

### • Normality Judgment

Judge OK and clear the NG when the malfunction criteria below are completed.

### Judgment Value

Malfunction Criteria	Threshold Value
Terminal voltage when ECM outputs OFF signal.	High

## 6. DTC CLEAR CONDITION

- When the OK idling cycle was completed 40 times in a row
- When "Clear Memory" was performed

## 7. MALFUNCTION INDICATOR LIGHT CLEAR CONDITION

- When the OK driving cycle was completed 3 times in a row
- When "Clear Memory" was performed

## 8. FAIL SAFE

Open PCV solenoid.

## 9. ECM OPERATION AT DTC SETTING

Memorize the freeze frame data. (For test mode \$02)

# DIAGNOSTIC TROUBLE CODE (DTC) DETECTING CRITERIA

## GENERAL DESCRIPTION

### AX:DTC P0448 — EVAPORATIVE EMISSION CONTROL SYSTEM VENT CONTROL CIRCUIT SHORTED —

#### 1. OUTLINE OF DIAGNOSIS

Detect the short circuit of drain valve.

Judge NG when the ECU output level is not equal to the actual terminal level.

#### 2. COMPONENT DESCRIPTION

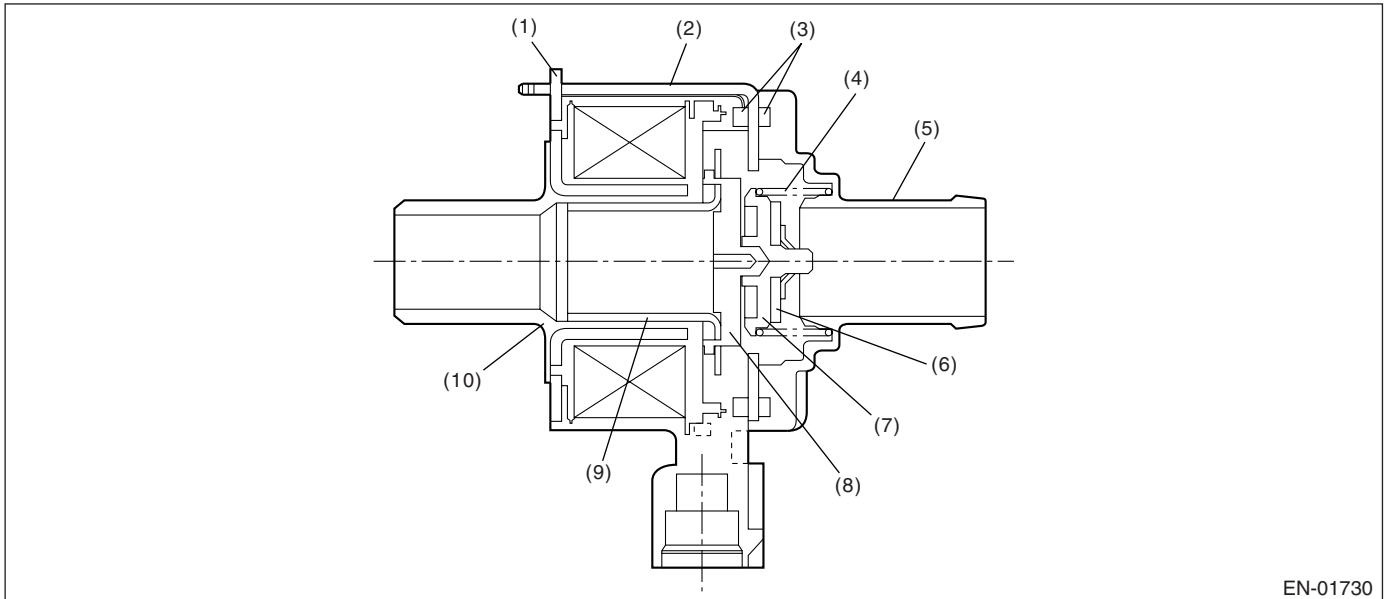

EN-01730

- (1) Magnetic plate
- (2) Yoke
- (3) Packing
- (4) Spring
- (5) Valve seat

- (6) Valve
- (7) Plate
- (8) Retainer
- (9) Movable core
- (10) Bobbin

#### 3. ENABLE CONDITION

Secondary Parameter	Enable Condition
Engine speed	$\geq 500$ rpm
Battery voltage	$\geq 8$ V
After starting the engine	1 second or more
Ignition switch	ON

#### 4. GENERAL DRIVING CYCLE

Perform the diagnosis continuously after starting the engine.

# DIAGNOSTIC TROUBLE CODE (DTC) DETECTING CRITERIA

GENERAL DESCRIPTION

## 5. DIAGNOSTIC METHOD

### • Abnormality Judgment

Judge NG when the continuous time until completing the malfunction criteria below become more than time (2.5 seconds) needed for diagnosis.

### Judgment Value

Malfunction Criteria	Threshold Value
Terminal voltage when ECM outputs ON signal.	High

**Time Needed for Diagnosis:** 2.5 seconds

**Malfunction Indicator Light Illumination:** Illuminates when malfunction occurs in 2 continuous driving cycles.

### • Normality Judgment

Judge OK and clear the NG when the malfunction criteria below are completed.

### Judgment Value

Malfunction Criteria	Threshold Value
Terminal voltage when ECM outputs ON signal.	Low

## 6. DTC CLEAR CONDITION

- When the OK idling cycle was completed 40 times in a row
- When "Clear Memory" was performed

## 7. MALFUNCTION INDICATOR LIGHT CLEAR CONDITION

- When the OK driving cycle was completed 3 times in a row
- When "Clear Memory" was performed

## 8. FAIL SAFE

Open PCV solenoid.

## 9. ECM OPERATION AT DTC SETTING

Memorize the freeze frame data. (For test mode \$02)

# DIAGNOSTIC TROUBLE CODE (DTC) DETECTING CRITERIA

## GENERAL DESCRIPTION

### AY:DTC P0451 — EVAPORATIVE EMISSION CONTROL SYSTEM PRESSURE SENSOR RANGE/PERFORMANCE —

#### 1. OUTLINE OF DIAGNOSIS

Detect the malfunction of tank pressure sensor output property.

Judge NG when there is little variation in the fuel tank pressure even if the vehicle is in driving status where there must be variation in the fuel tank pressure considering the fuel temperature and fuel level.

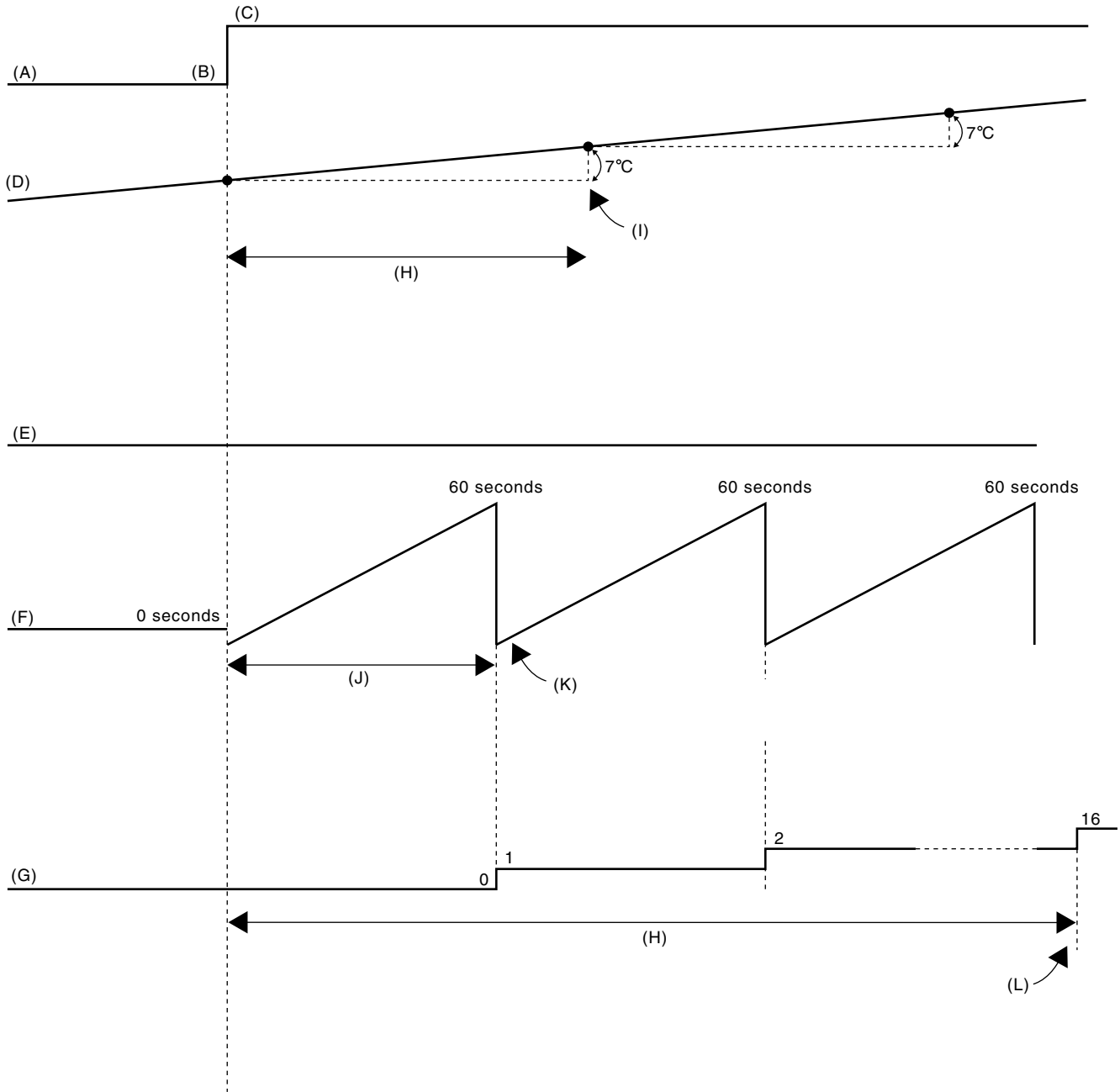

EN-01731

# DIAGNOSTIC TROUBLE CODE (DTC) DETECTING CRITERIA

GENERAL DESCRIPTION

- (A) Execution condition
- (B) Incomplete
- (C) Completed
- (D) Fuel temperature
- (E) Vehicle speed > 0 km/h (0 MPH)
- (F) Timer TMLVD
- (G) Fuel level variation count
- (H) Measure the max. and min. values of fuel tank pressure during this period.
- (I) NG condition (a) is completed if there is no difference between max. and min. values at this point. Otherwise, OK condition (a) is completed if there is a difference.
- (J) Measure the max. and min. values of fuel level during 60 seconds.
- (K) Number of the fuel level variation count is incremented if there is the difference of 2 or more between max. and min. values at this point.
- (L) NG condition (b) is completed if there is no difference between max. and min. values at this point. Otherwise, OK condition (b) is completed if there is a difference.

- If NG condition (a) & (b) are experienced, NG results. (If there is OK, NG experience becomes unexperienced.)
- If OK conditions (a) & (b) are experienced, OK results. (If there is NG, OK experience becomes unexperienced.)

## 2. COMPONENT DESCRIPTION

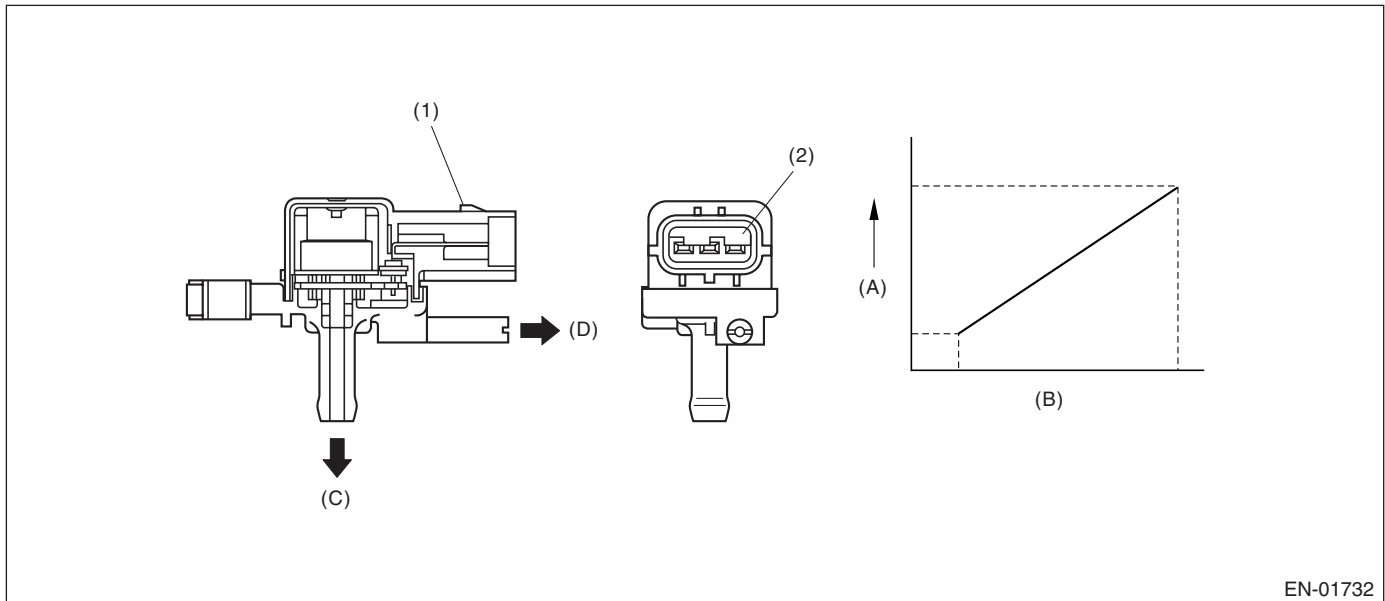

EN-01732

- (1) Connector
- (2) Terminal

- (A) Output voltage
- (B) Input voltage
- (C) To fuel tank
- (D) To tank pressure switching solenoid valve

## 3. ENABLE CONDITION

Secondary Parameters	Enable Conditions
Timer after starting the engine	≥ 30 seconds
Fuel level	≥ 9 ℓ (2.4 US gal, 2.0 Imp gal)

## 4. GENERAL DRIVING CYCLE

Perform the diagnosis continuously in 30 seconds after starting the engine.

# DIAGNOSTIC TROUBLE CODE (DTC) DETECTING CRITERIA

## GENERAL DESCRIPTION

### 5. DIAGNOSTIC METHOD

- (1) There is no tank pressure variation when there is fuel temperature variation of 7°C (45°F).
- (2) There is no tank pressure variation even when there is fuel level variation of 2 ℓ (0.5 US gal, 0.4 Imp gal) or more every 60 seconds.

Judge NG when both of the conditions above are experienced.

#### • Abnormality Judgment

Judge NG when the conditions below are completed.

#### Judgment Value

Malfunction Criteria	Threshold Value
Change of fuel temperature	≥ 7°C (12.6°F)
Max. – min. tank pressure	≤ 100 Pa (0.75 mmHg, 0.03 inHg)
Total time lapse where there is fuel level variation of 2 ℓ (0.5 US gal, 0.4 Imp gal) or more per minute.	≥ 10 minutes

**Time Needed for Diagnosis:** 10 minutes

**Malfunction Indicator Light Illumination:** Illuminates when malfunction occurs in 2 continuous driving cycles.

#### • Normality Judgment

Judge OK when both of the conditions below are experienced, and clear NG.

#### Judgment Value

Malfunction Criteria	Threshold Value
Max. – min. tank pressure (During fuel temperature variation of 7°C (45°F))	> 100 Pa (0.75 mmHg, 0.03 inHg)
Change of fuel temperature	≥ 7°C (45°F)

Malfunction Criteria	Threshold Value
Max. – min. tank pressure (During time lapse below)	> 100 Pa (0.75 mmHg, 0.03 inHg)
Total time lapse where there is fuel level variation of 2 ℓ (0.5 US gal, 0.4 Imp gal) or more per minute.	≥ 10 minutes

### 6. DTC CLEAR CONDITION

- When the OK idling cycle was completed 40 times in a row
- When “Clear Memory” was performed

### 7. MALFUNCTION INDICATOR LIGHT CLEAR CONDITION

- When the OK driving cycle was completed 3 times in a row
- When “Clear Memory” was performed

### 8. FAIL SAFE

Fix the fuel tank pressure at 0 kPa (0 mmHg, 0 inHg).

### 9. ECM OPERATION AT DTC SETTING

Memorize the freeze frame data. (For test mode \$02)



## AZ:DTC P0452 — EVAPORATIVE EMISSION CONTROL SYSTEM PRESSURE SENSOR LOW INPUT —

### 1. OUTLINE OF DIAGNOSIS

Detect the open or short circuit of tank pressure sensor.  
Judge NG when out of the standard value.

### 2. COMPONENT DESCRIPTION

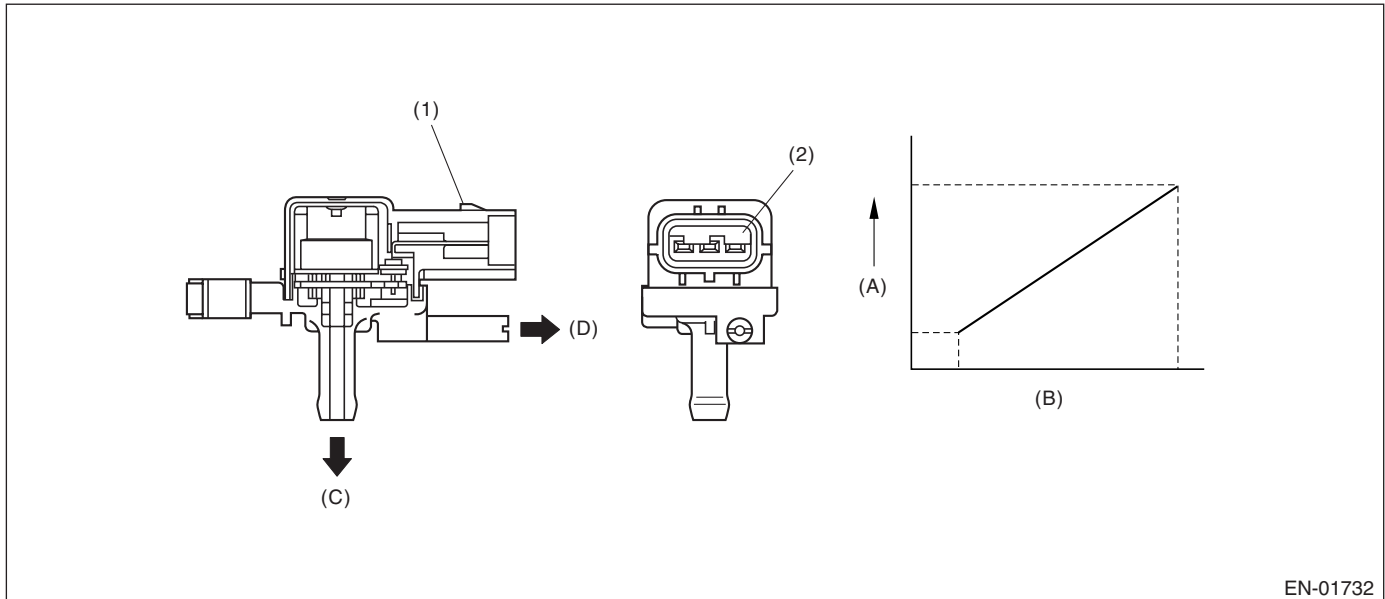

- (1) Connector
- (2) Terminal

- (A) Output voltage
- (B) Input voltage
- (C) To fuel tank
- (D) To tank pressure switching solenoid valve

EN-01732

### 3. ENABLE CONDITION

Secondary Parameters	Enable Conditions
Engine speed	$\geq 500$ rpm
Battery voltage	$\geq 10$ V
After engine starting	2 seconds or more
Pressure control solenoid valve	Open
Drain valve	Close
Canister purge control solenoid valve duty ratio	$\leq 0\%$

### 4. GENERAL DRIVING CYCLE

Perform the diagnosis continuously in 2 seconds after starting the engine.

### 5. DIAGNOSTIC METHOD

#### • Abnormality Judgment

Judge NG when the continuous time until completing all of the malfunction criteria below becomes more than time needed for diagnosis.

#### Judgment Value

Malfunction Criteria	Threshold Value
Output voltage	$< 0.2$ V

# DIAGNOSTIC TROUBLE CODE (DTC) DETECTING CRITERIA

## GENERAL DESCRIPTION

---

**Time Needed for Diagnosis:** 20 seconds

**Malfunction Indicator Light Illumination:** Illuminates as soon as malfunction occurs.

• **Normality Judgment**

Judge OK and clear the NG when the malfunction criteria below are completed

**Judgment Value**

Malfunction Criteria	Threshold Value
Output voltage	$\geq 0.2$ V

### 6. DTC CLEAR CONDITION

- When the OK idling cycle was completed 40 times in a row
- When "Clear Memory" was performed

### 7. MALFUNCTION INDICATOR LIGHT CLEAR CONDITION

- When the OK driving cycle was completed 3 times in a row
- When "Clear Memory" was performed

### 8. FAIL SAFE

Fix the fuel tank pressure at 0 kPa (0 mmHg, 0 inHg).

### 9. ECM OPERATION AT DTC SETTING

Memorize the freeze frame data. (For test mode \$02)

# DIAGNOSTIC TROUBLE CODE (DTC) DETECTING CRITERIA

GENERAL DESCRIPTION

## BA:DTC P0453 — EVAPORATIVE EMISSION CONTROL SYSTEM PRESSURE SENSOR HIGH INPUT —

### 1. OUTLINE OF DIAGNOSIS

Detect the open or short circuit of tank pressure sensor.  
Judge NG when out of the standard value.

### 2. COMPONENT DESCRIPTION

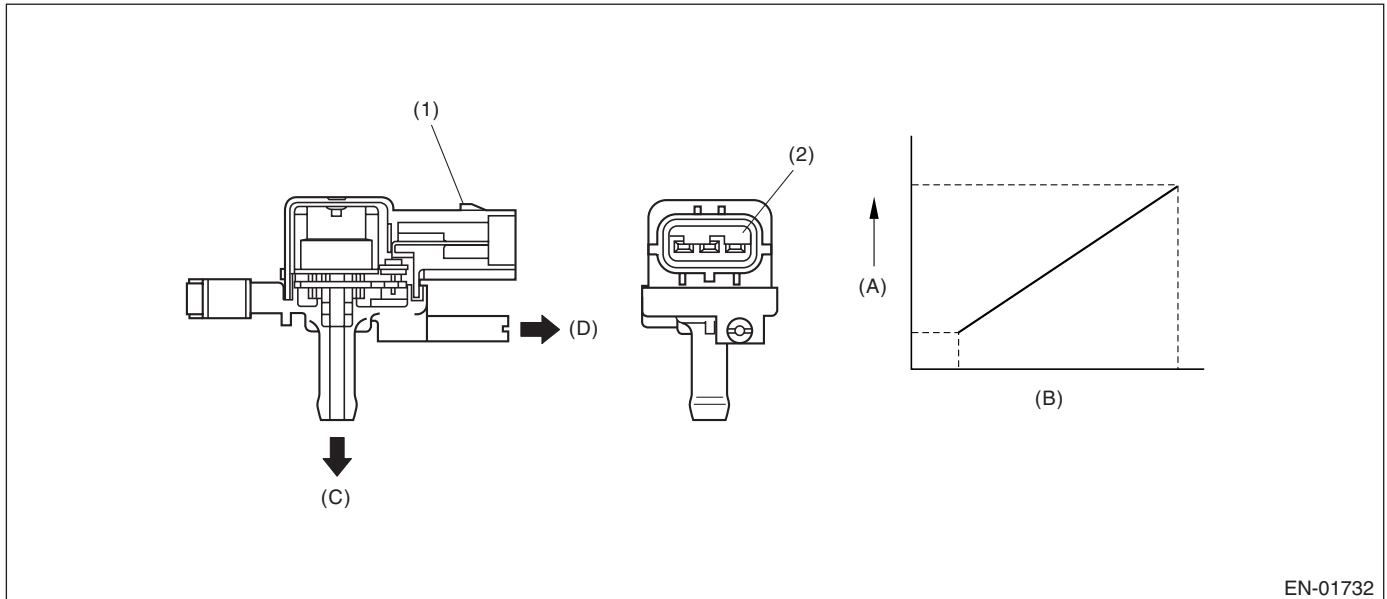

- (1) Connector
- (2) Terminal

- (A) Output voltage
- (B) Input voltage
- (C) To fuel tank
- (D) To tank pressure switching solenoid valve

### 3. ENABLE CONDITION

Secondary Parameters	Enable Conditions
Engine speed	$\geq 500$ rpm
Battery voltage	$\geq 10$ V
After engine starting	2 seconds or more

### 4. GENERAL DRIVING CYCLE

Perform the diagnosis continuously in 2 seconds after starting the engine.

# DIAGNOSTIC TROUBLE CODE (DTC) DETECTING CRITERIA

## GENERAL DESCRIPTION

---

### 5. DIAGNOSTIC METHOD

#### • Abnormality Judgment

Judge NG when the cumulative time until completing all of the malfunction criteria below becomes more than the time (20 seconds) needed for diagnosis.

#### Judgment Value

Malfunction Criteria	Threshold Value
Output voltage	$\geq 4.8$ V
Fuel temperature	$< 35^{\circ}\text{C}$ ( $95^{\circ}\text{F}$ )
Barometric pressure	$\geq 76$ kPa (568 mmHg, 22.4 inHg)

**Time Needed for Diagnosis:** 20 seconds

**Malfunction Indicator Light Illumination:** Illuminates as soon as malfunction occurs.

#### • Normality Judgment

Judge OK and clear the NG when the malfunction criteria below are completed.

#### Judgment Value

Malfunction Criteria	Threshold Value
Output voltage	$< 4.8$ V

### 6. DTC CLEAR CONDITION

- When the OK idling cycle was completed 40 times in a row
- When "Clear Memory" was performed

### 7. MALFUNCTION INDICATOR LIGHT CLEAR CONDITION

- When the OK driving cycle was completed 3 times in a row
- When "Clear Memory" was performed

### 8. FAIL SAFE

Fix the fuel tank pressure at 0 kPa (0 mmHg, 0 inHg).

### 9. ECM OPERATION AT DTC SETTING

Memorize the freeze frame data. (For test mode \$02)

# DIAGNOSTIC TROUBLE CODE (DTC) DETECTING CRITERIA

GENERAL DESCRIPTION

---

## **BB:DTC P0456 — EVAPORATIVE EMISSION CONTROL SYSTEM LEAK DETECTED (VERY SMALL LEAK) —**

### **1. OUTLINE OF DIAGNOSIS**

For detecting conditions, refer to DTC P0442 EVAPORATIVE EMISSION CONTROL SYSTEM LEAK DETECTED (SMALL LEAK). <Ref. to GD(H4SO)-114, DTC P0442 — EVAPORATIVE EMISSION CONTROL SYSTEM LEAK DETECTED (SMALL LEAK) —, Diagnostic Trouble Code (DTC) Detecting Criteria.>

## **BC:DTC P0457 — EVAPORATIVE EMISSION CONTROL SYSTEM LEAK DETECTED (FUEL CAP LOOSE/OFF) —**

### **1. OUTLINE OF DIAGNOSIS**

For detecting conditions, refer to DTC P0442 EVAPORATIVE EMISSION CONTROL SYSTEM LEAK DETECTED (SMALL LEAK). <Ref. to GD(H4SO)-114, DTC P0442 — EVAPORATIVE EMISSION CONTROL SYSTEM LEAK DETECTED (SMALL LEAK) —, Diagnostic Trouble Code (DTC) Detecting Criteria.>

# DIAGNOSTIC TROUBLE CODE (DTC) DETECTING CRITERIA

## GENERAL DESCRIPTION

### BD:DTC P0458 — EVAPORATIVE EMISSION CONTROL SYSTEM PURGE CONTROL VALVE CIRCUIT LOW —

#### 1. OUTLINE OF DIAGNOSIS

Detect the open or short circuit of purge control solenoid valve.  
Judge NG when ECM output level is different from actual terminal level.

#### 2. COMPONENT DESCRIPTION

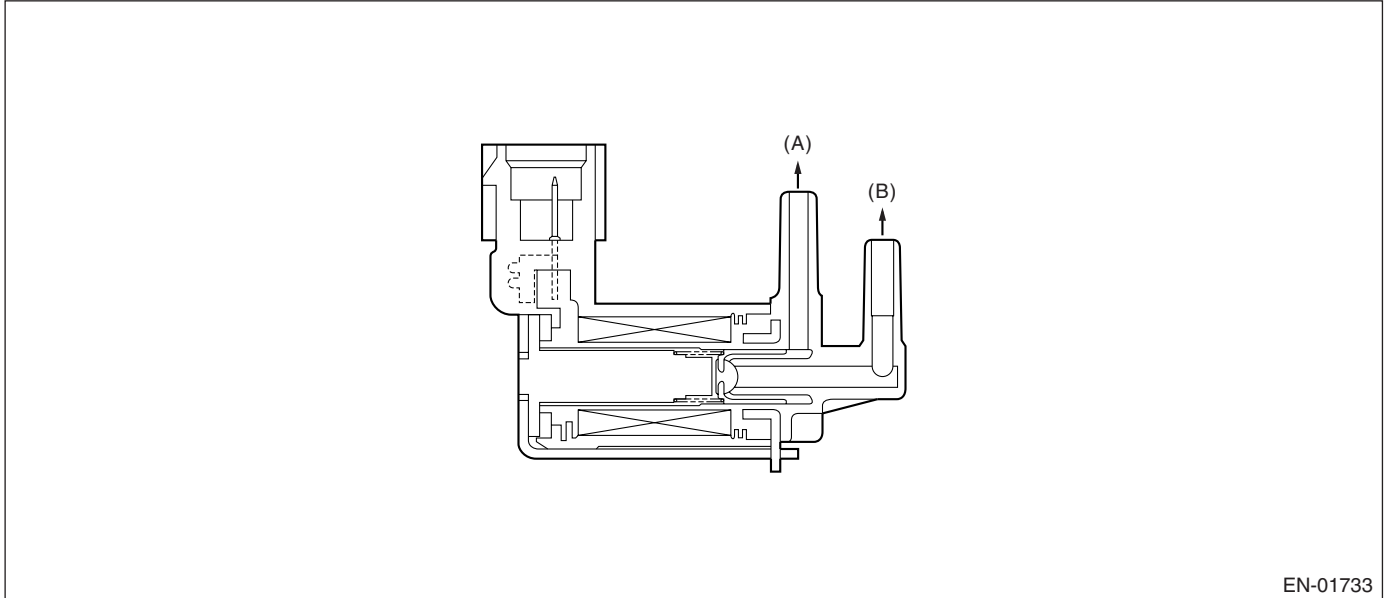

- (A) To canister
- (B) To intake manifold

#### 3. ENABLE CONDITION

Secondary Parameters	Enable Conditions
Engine speed	$\geq 500$ rpm
Battery voltage	$\geq 8$ V
After engine starting	1 second or more
Ignition switch	ON

#### 4. GENERAL DRIVING CYCLE

Perform the diagnosis continuously after starting the engine.

#### 5. DIAGNOSTIC METHOD

##### • Abnormality Judgment

Judge NG when the cumulative time until completing all the malfunction criteria below becomes more than the time (2 seconds) needed for diagnosis.

##### Judgment Value

Malfunction Criteria	Threshold Value
Duty ratio of "ON"	$< 75\%$
Terminal output voltage when ECM outputs OFF signal	Low

**Time Needed for Diagnosis:** 2.5 seconds

**Malfunction Indicator Light Illumination:** Illuminates when malfunction occurs in 2 continuous driving cycles.

# DIAGNOSTIC TROUBLE CODE (DTC) DETECTING CRITERIA

GENERAL DESCRIPTION

## • Normality Judgment

Judge OK when the cumulative time until completing all the malfunction criteria below becomes more than 1 second.

### Judgment Value

Malfunction Criteria	Threshold Value
Duty ratio of "ON"	< 75%
Terminal output voltage when ECM outputs OFF signal	High

## 6. DTC CLEAR CONDITION

- When the OK idling cycle is completed 40 times in a row
- When "Clear Memory" was performed

## 7. MALFUNCTION INDICATOR LIGHT CLEAR CONDITION

- When the OK driving cycle was completed 3 times in a row
- When "Clear Memory" was performed

## 8. FAIL SAFE

None

## 9. ECM OPERATION AT DTC

Memorize the freeze frame data. (For test mode \$02)

# DIAGNOSTIC TROUBLE CODE (DTC) DETECTING CRITERIA

## GENERAL DESCRIPTION

### BE:DTC P0459 — EVAPORATIVE EMISSION CONTROL SYSTEM PURGE CONTROL VALVE CIRCUIT HIGH —

#### 1. OUTLINE OF DIAGNOSIS

Detect the open or short circuit of purge control solenoid valve.  
Judge NG when ECM output level is different from actual terminal level.

#### 2. COMPONENT DESCRIPTION

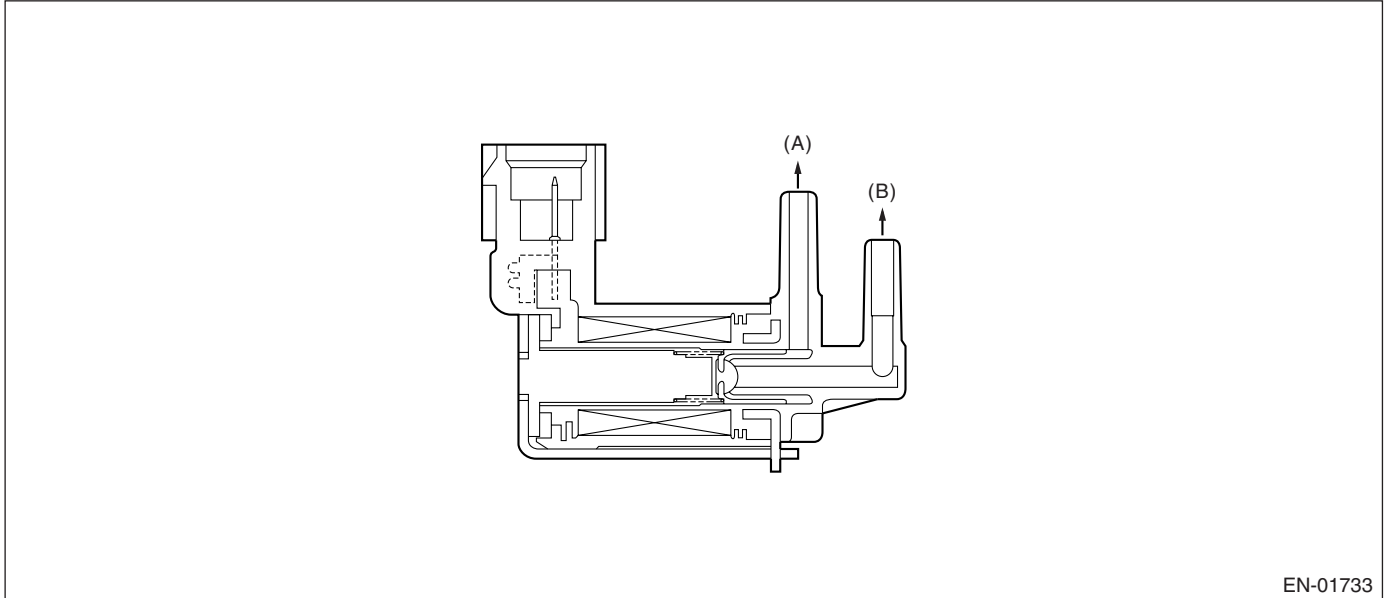

- (A) To canister
- (B) To intake manifold

#### 3. ENABLE CONDITION

Secondary Parameters	Enable Conditions
Engine speed	$\geq 500$ rpm
Battery voltage	$\geq 8$ V
After engine starting	1 second or more
Ignition switch	ON

#### 4. GENERAL DRIVING CYCLE

Perform the diagnosis continuously after starting the engine.

#### 5. DIAGNOSTIC METHOD

##### • Abnormality Judgment

Judge NG when the cumulative time until completing the malfunction criteria below becomes more than the time (2 seconds) needed for diagnosis.

##### Judgment Value

Malfunction Criteria	Threshold Value
Duty ratio of "ON"	$> 25\%$
Terminal output voltage when ECM outputs ON signal	High

**Time Needed for Diagnosis:** 2.5 seconds

**Malfunction Indicator Light Illumination:** Illuminates when malfunction occurs in 2 continuous driving cycles.



# DIAGNOSTIC TROUBLE CODE (DTC) DETECTING CRITERIA

GENERAL DESCRIPTION

## • Normality Judgment

Judge OK when the cumulative time until completing the malfunction criteria below becomes more than 1 second.

### Judgment Value

Malfunction Criteria	Threshold Value
Duty ratio of "ON"	> 25%
Terminal output voltage when ECM outputs OFF signal	Low

## 6. DTC CLEAR CONDITION

- When the OK idling cycle is completed 40 times in a row
- When "Clear Memory" was performed

## 7. MALFUNCTION INDICATOR LIGHT CLEAR CONDITION

- When the OK driving cycle was completed 3 times in a row
- When "Clear Memory" was performed

## 8. FAIL SAFE

None

## 9. ECM OPERATION AT DTC

Memorize the freeze frame data. (For test mode \$02)

# DIAGNOSTIC TROUBLE CODE (DTC) DETECTING CRITERIA

## GENERAL DESCRIPTION

### BF:DTC P0461 — FUEL LEVEL SENSOR CIRCUIT RANGE/PERFORMANCE —

#### 1. OUTLINE OF DIAGNOSIS

Detect the malfunction of fuel level sensor output property.

Judge NG by the difference between max. and min. value of fuel level during every 160 km (100 miles) driving distance converted from vehicle speed.

#### 2. COMPONENT DESCRIPTION

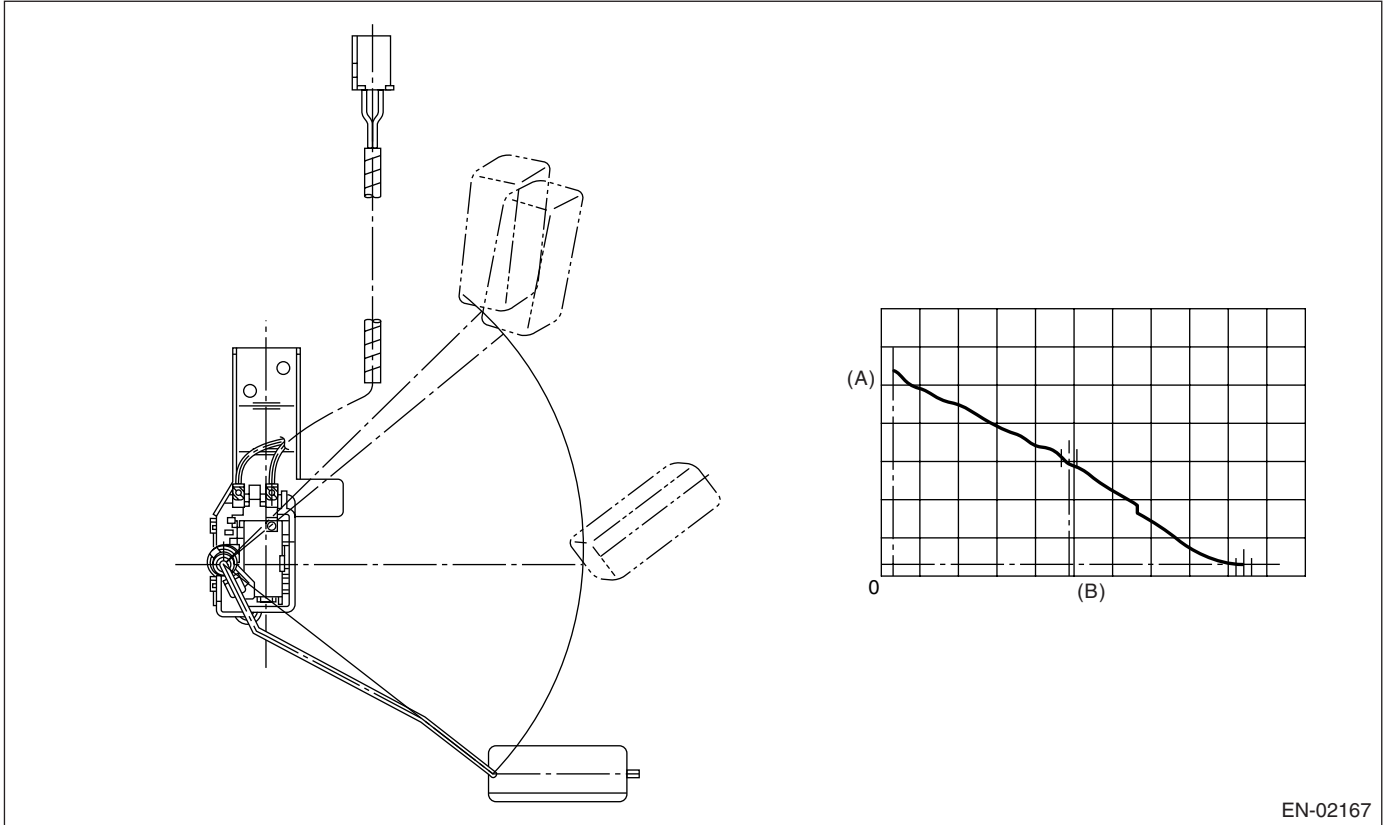

- (A) Fuel level (L)
- (B) Resistance ( $\Omega$ )

#### 3. ENABLE CONDITION

Secondary Parameters	Enable Conditions
None	

#### 4. GENERAL DRIVING CYCLE

Always perform the diagnosis continuously.

#### 5. DIAGNOSTIC METHOD

##### • Abnormality Judgment

Judge NG when all the malfunction criteria below are completed.

##### Judgment Value

Malfunction Criteria	Threshold Value
Max. – min. fuel level	< 10 l (2.6 US gal, 2.2 Imp gal)
Trip distance from last fill up	$\geq$ 160 km (100 miles)

**Time Needed for Diagnosis:** Not determined.

# DIAGNOSTIC TROUBLE CODE (DTC) DETECTING CRITERIA

GENERAL DESCRIPTION

**Malfunction Indicator Light Illumination:** Illuminates when malfunction occurs in 2 continuous driving cycles.

## • Normality Judgment

Judge OK and clear the NG when the malfunction criteria below are completed.

## Judgment Value

Malfunction Criteria	Threshold Value
Max. – min. fuel level	$\geq 10 \ell$ (2.6 US gal, 2.2 Imp gal)

## 6. DTC CLEAR CONDITION

- When the OK idling cycle is completed 40 times in a row
- When “Clear Memory” was performed

## 7. MALFUNCTION INDICATOR LIGHT CLEAR CONDITION

- When the OK driving cycle is completed 3 times in a row
- When “Clear Memory” was performed

## 8. FAIL SAFE

None

## 9. ECM OPERATION AT DTC SETTING

Memorize the freeze frame data. (For test mode \$02)

# DIAGNOSTIC TROUBLE CODE (DTC) DETECTING CRITERIA

## GENERAL DESCRIPTION

### BG:DTC P0462 — FUEL LEVEL SENSOR CIRCUIT LOW INPUT —

#### 1. OUTLINE OF DIAGNOSIS

Detect the open or short circuit of fuel level sensor.  
Judge NG when out of the standard value.

#### 2. COMPONENT DESCRIPTION

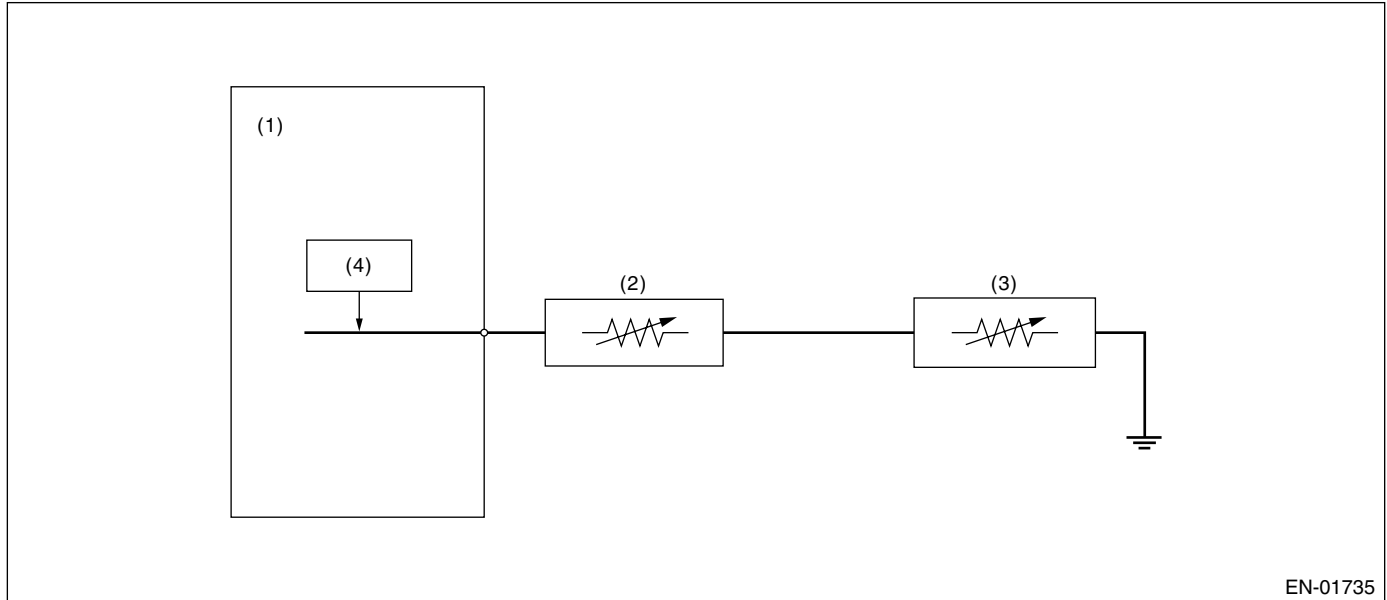

- (1) Engine control module (ECM)
- (2) Fuel level sensor
- (3) Fuel sub level sensor
- (4) Detecting circuit

#### 3. ENABLE CONDITION

Secondary Parameters	Enable Conditions
Battery voltage	8 — 16 V
Ignition switch	ON

#### 4. GENERAL DRIVING CYCLE

Always perform the diagnosis continuously.

#### 5. DIAGNOSTIC METHOD

Judge NG when the continuous time of completing the malfunction criteria below becomes more than the time (2.5 seconds) needed for diagnosis, and then judge OK and clear the NG when the malfunction criteria below are not completed.

##### Judgment Value

Malfunction Criteria	Threshold Value
Output voltage	$\leq 0.02$ V

**Time Needed for Diagnosis:** 2.5 seconds

**Malfunction Indicator Light Illumination:** Illuminates when malfunction occurs in 2 continuous driving cycles.

#### 6. DTC CLEAR CONDITION

- When the OK driving cycle is completed 40 times in a row
- When "Clear Memory" was performed

# DIAGNOSTIC TROUBLE CODE (DTC) DETECTING CRITERIA

GENERAL DESCRIPTION

---

## 7. MALFUNCTION INDICATOR LIGHT CLEAR CONDITION

- When the OK driving cycle is completed 3 times in a row
- When "Clear Memory" was performed

## 8. FAIL SAFE

None

## 9. ECM OPERATION AT DTC SETTING

Memorize the freeze frame data. (For test mode \$02)

# DIAGNOSTIC TROUBLE CODE (DTC) DETECTING CRITERIA

## GENERAL DESCRIPTION

### BH:DTC P0463 — FUEL LEVEL SENSOR CIRCUIT HIGH INPUT —

#### 1. OUTLINE OF DIAGNOSIS

Detect the open or short circuit of fuel level sensor.  
Judge NG when out of the standard value.

#### 2. COMPONENT DESCRIPTION

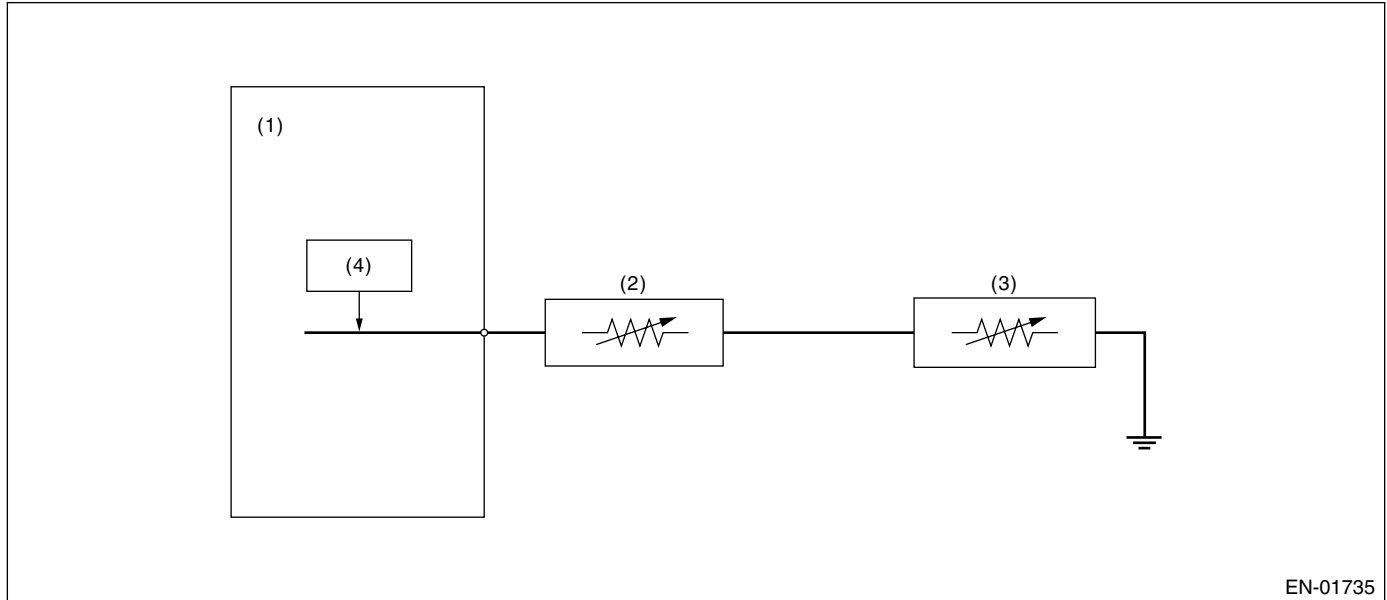

- (1) Engine control module (ECM)
- (2) Fuel level sensor
- (3) Fuel sub level sensor
- (4) Detecting circuit

#### 3. ENABLE CONDITION

Secondary Parameter	Enable Conditions
Battery voltage	8 — 16 V
Ignition switch	ON

#### 4. GENERAL DRIVING CYCLE

Always perform the diagnosis continuously.

#### 5. DIAGNOSTIC METHOD

Judge NG when the cumulative time until completing the malfunction criteria below becomes more than the time (0.5 seconds) needed for diagnosis, and then judge OK and clear the NG when the malfunction criteria below are not completed.

##### Judgment Value

Malfunction Criteria	Threshold Value
Output voltage	$\geq 5.08$ V

**Time Needed for Diagnosis:** 2.5 seconds

**Malfunction Indicator Light Illumination:** Illuminates when malfunction occurs in 2 continuous driving cycles.

#### 6. DTC CLEAR CONDITION

- When the OK idling cycle is completed 40 times in a row
- When “Clear Memory” was performed

# DIAGNOSTIC TROUBLE CODE (DTC) DETECTING CRITERIA

GENERAL DESCRIPTION

---

## 7. MALFUNCTION INDICATOR LIGHT CLEAR CONDITION

- When the OK driving cycle is completed 3 times in a row
- When "Clear Memory" was performed

## 8. FAIL SAFE

None

## 9. ECM OPERATION AT DTC SETTING

Memorize the freeze frame data. (For test mode \$02)

# DIAGNOSTIC TROUBLE CODE (DTC) DETECTING CRITERIA

## GENERAL DESCRIPTION

---

### BI: DTC P0464 — FUEL LEVEL SENSOR CIRCUIT INTERMITTENT —

#### 1. OUTLINE OF DIAGNOSIS

Detect the malfunction of unstable output from fuel level sensor because of noise.

Judge NG by comparing the max value and cumulative value of the amount of output voltage variation from fuel level sensor with threshold value.

#### 2. ENABLE CONDITION

Secondary Parameters	Enable Conditions
Engine speed	≥ 500 rpm
Battery voltage	> 10.9 V
After engine starting	1 second or more
Idle switch	ON
Fuel level	9 — 51 ℓ (2.4 — 13.5 US gal, 2.0 — 11.2 Imp gal)
Vehicle speed = 0 km/h (0 MPH)	10 seconds or more
Ignition switch	ON
Tank pressure difference between Max. and Min. (12.8 seconds)	< 50 Pa (0.38 mmHg, 0.015 inHg)
Battery voltage difference between Max. and Min. (12.8 seconds)	< 0.4 V

#### 3. GENERAL DRIVING CYCLE

Perform the diagnosis continuously at idling.



# DIAGNOSTIC TROUBLE CODE (DTC) DETECTING CRITERIA

GENERAL DESCRIPTION

## 4. DIAGNOSTIC METHOD

Calculate the max. value of the amount of output voltage variation from fuel level sensor and cumulative value during 12.8 seconds. Comparing the max value and cumulative value with the threshold value, and judge OK when the both do not go over the threshold value. Otherwise, when one of them goes over the threshold, count the counter up. Judge the ECM is troubled when the counter increased 4 times in a row.

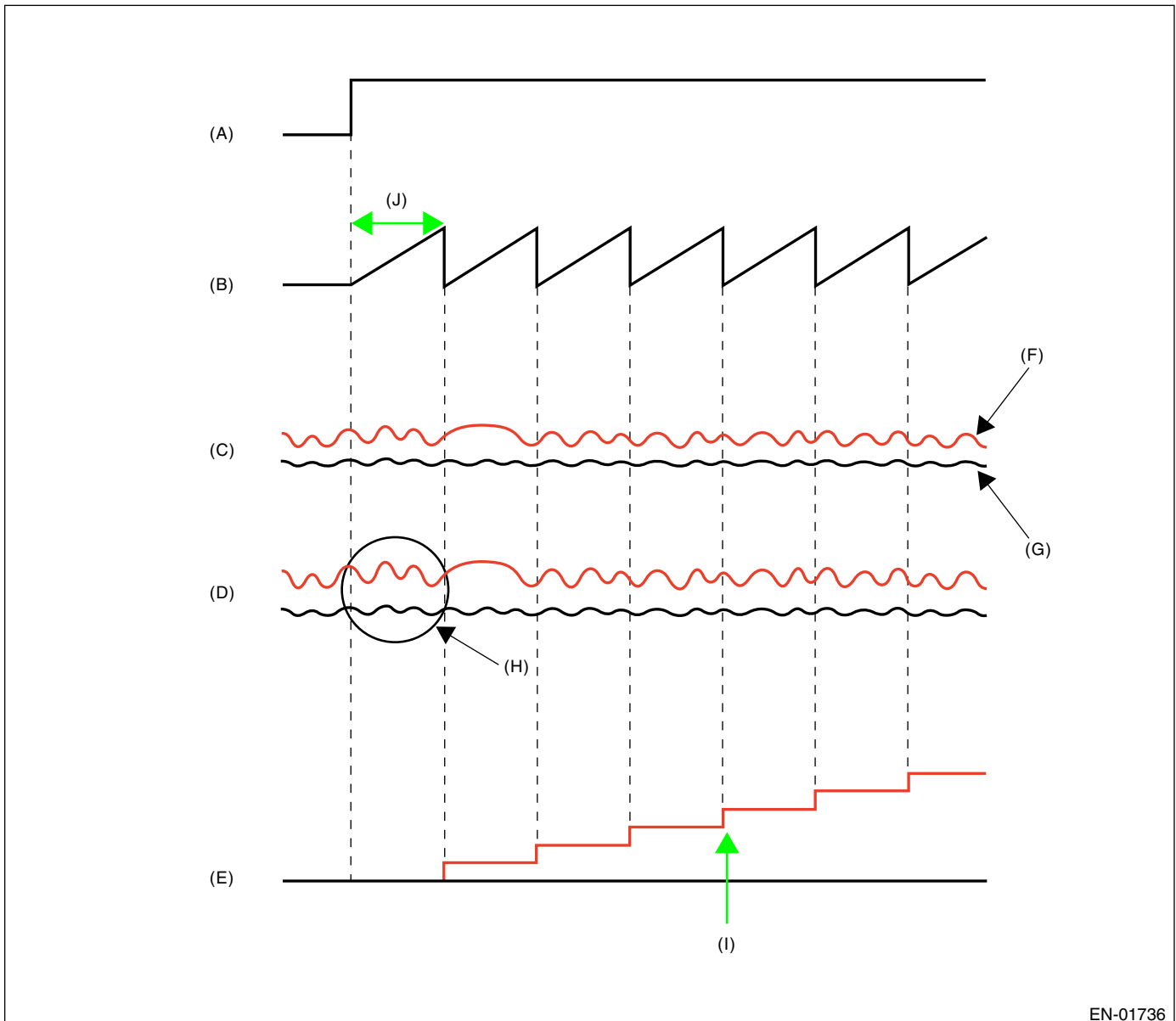

EN-01736

- |                                                   |                                                                           |
|---------------------------------------------------|---------------------------------------------------------------------------|
| (A) Diagnosis condition                           | (G) Normal                                                                |
| (B) Diagnosis timer                               | (H) Regard the Max. value as delvflmx and the cumulative value as sumvfl. |
| (C) Fuel level sensor A/D value                   | (I) NG at 4 counts                                                        |
| (D) Amount of Fuel level output voltage variation | (J) 12.8 s                                                                |
| (E) Diagnosis counter                             |                                                                           |
| (F) Malfunction                                   |                                                                           |

# DIAGNOSTIC TROUBLE CODE (DTC) DETECTING CRITERIA

## GENERAL DESCRIPTION

---

### • Abnormality Judgment

Judge NG when the malfunction criteria below are completed.

#### Judgment Value

Malfunction Criteria	Threshold Value
Integrated times of the condition reaching follows, <ul style="list-style-type: none"><li>• DVFLMAX <math>\geq</math> 0.88 V</li><li>• SUMVFL <math>\geq</math> 14.08 V</li></ul> DVFLMAX is max. value of sensor output during 12.8 seconds. SUMVFL is cumulative value of sensor output deviation during 12.8 seconds.	$\geq$ 4 times

**Time Needed for Diagnosis:** 12.8 seconds  $\times$  4 times

**Malfunction Indicator Light Illumination:** Illuminates when malfunction occurs in 2 continuous driving cycles.

### • Normality Judgment

Judge OK and clear the NG when all the malfunction criteria below are completed.

#### Judgment Value

Malfunction Criteria	Threshold Value
DVFLMAX	$<$ 0.88 V
SUMVFL	$<$ 14.08 V

## 5. DTC CLEAR CONDITION

- When the OK idling cycle is completed 40 times in a row
- When "Clear Memory" was performed

## 6. MALFUNCTION INDICATOR LIGHT CLEAR CONDITION

- When the OK driving cycle is completed 3 times in a row
- When "Clear Memory" was performed

## 7. FAIL SAFE

None

## 8. ECM OPERATION AT DTC SETTING

Memorize the freeze frame data. (For test mode \$02)

# DIAGNOSTIC TROUBLE CODE (DTC) DETECTING CRITERIA

GENERAL DESCRIPTION

## BJ:DTC P0483 — COOLING FAN RATIONALITY CHECK —

### 1. OUTLINE OF DIAGNOSIS

Detect the malfunction of radiator fan.

Judge NG when the engine coolant temperature decreases slowly even if the radiator fan started rotating.

### 2. ENABLE CONDITION

Secondary Parameters	Enable Conditions
Engine coolant temperature	$\geq 100^{\circ}\text{C}$ ( $212^{\circ}\text{F}$ )

### 3. GENERAL DRIVING CYCLE

Perform the diagnosis continuously when the engine coolant temperature is very high (more than  $100^{\circ}\text{C}$  ( $212^{\circ}\text{F}$ )).

### 4. DIAGNOSTIC METHOD

Check the engine coolant temperature (A/D value) when the radiator fan is ON since the radiator fan output turns from OFF to ON with all of the malfunction conditions below completed.

Secondary Parameters	Enable Conditions
Engine speed	600 — 900 rpm
Idle switch	ON
Vehicle speed	0 km/h (0 MPH)
Battery voltage	$\geq 10.9$ V

Judge NG when the cumulative time until completing the malfunction criteria below becomes more than the time (5 minutes) needed for diagnosis. Also Judge OK when the malfunction criteria below is not completed. And then clear NG.

#### Judgment Value

Malfunction Criteria	Threshold Value
Radiator fan signal change	From OFF to ON
Engine coolant temperature	$\geq 10.5^{\circ}\text{C}$ ( $50.9^{\circ}\text{F}$ )
Engine coolant temperature	Do not decrease

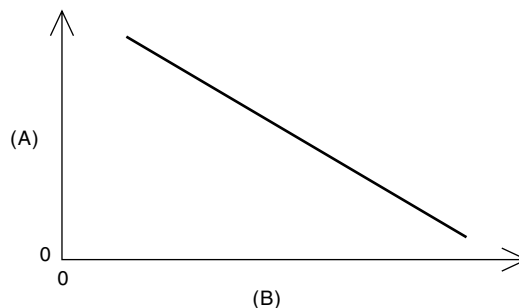

EN-01737

- (A) Engine coolant temperature  $^{\circ}\text{C}$  ( $^{\circ}\text{F}$ )
- (B) A/D value (V)

# DIAGNOSTIC TROUBLE CODE (DTC) DETECTING CRITERIA

## GENERAL DESCRIPTION

---

**Time Needed for Diagnosis:** 150 seconds

**Malfunction Indicator Light Illumination:** Illuminates when malfunction occurs in 2 continuous driving cycles.

### 5. DTC CLEAR METHOD

- When the OK idling cycle was completed 40 times in a row
- When "Clear Memory" was performed

### 6. MALFUNCTION INDICATOR LIGHT CLEAR CONDITION

- When the OK driving cycle was completed 3 times in a row
- When "Clear Memory" was performed

### 7. FAIL SAFE

None

### 8. ECM OPERATION AT DTC SETTING

Memorize the freeze frame data. (For test mode \$02)

# DIAGNOSTIC TROUBLE CODE (DTC) DETECTING CRITERIA

GENERAL DESCRIPTION

## BK:DTC P0502 — VEHICLE SPEED SENSOR CIRCUIT LOW INPUT —

### 1. OUTLINE OF DIAGNOSIS

- Detect the open or short circuit of vehicle speed.
- Judge NG when the vehicle speed is low while the vehicle speed is assumed to be high.

### 2. ENABLE CONDITION

Secondary Parameters	Enable Conditions
None	

### 3. GENERAL DRIVE CYCLE

Always perform the diagnosis continuously.

### 4. DIAGNOSTIC METHOD

Judge NG when the time of completing the malfunction criteria below becomes more than time needed for diagnosis. Judge OK when the vehicle speed is more than 4 km/h (2.5 MPH) and less than 224 km/h (140 MPH).

#### Judgment Value

Malfunction Criteria	Threshold Value
<b>Low side diagnosis (1)</b>	
Cumulative time when the malfunction criteria below are completed	≥ 20 seconds
Idle switch	OFF
Injector pulse	≥ 2.5 milliseconds
Engine speed	≥ 2,800 rpm
Neutral switch	OFF
Vehicle speed signal (353 mS)	< 1

#### Time Needed for Diagnosis:

Low side                      20 seconds

**Malfunction Indicator Light Illumination:** Illuminates as soon as malfunction occurs.

### 5. DTC CLEAR CONDITION

- When the OK idling cycle is completed 40 times in a row
- When “Clear Memory” was performed

### 6. MALFUNCTION INDICATOR LIGHT CLEAR CONDITION

- When the OK driving cycle was completed 3 times in a row.
- When “Clear Memory” was performed

### 7. FAIL SAFE

None

### 8. ECM OPERATION AT DTC

Memorize the freeze frame data. (For test mode \$02)

# DIAGNOSTIC TROUBLE CODE (DTC) DETECTING CRITERIA

## GENERAL DESCRIPTION

### BL:DTC P0503 — VEHICLE SPEED SENSOR INTERMITTENT/ERRATIC/HIGH —

#### 1. OUTLINE OF DIAGNOSIS

- Detect the open or short circuit of vehicle speed.
- Judge NG when the vehicle speed is high while the vehicle speed is assumed to be low.

#### 2. ENABLE CONDITION

Secondary Parameters	Enable Conditions
None	

#### 3. GENERAL DRIVE CYCLE

Perform the diagnosis continuously.

#### 4. DIAGNOSTIC METHOD

Judge NG when the time of completing the malfunction criteria below becomes more than time needed for diagnosis. Judge OK when the vehicle speed is more than 4 km/h (2.5 MPH) and less than 224 km/h (140 MPH).

##### Judgment Value

Malfunction Criteria	Threshold Value
<b>High side diagnosis</b>	
Cumulative time when the malfunction criteria below are completed	≥ 5 seconds
Idle switch	OFF
Injector pulse	≤ 2.0 milliseconds
Engine speed	≤ 2,100 rpm
Neutral switch	OFF
Vehicle speed signal (353 mS)	≥ 56

##### Time Needed for Diagnosis:

High 5 seconds

**Malfunction Indicator Light Illumination:** Illuminates as soon as malfunction occurs.

#### 5. DTC CLEAR CONDITION

- When the OK idling cycle is completed 40 times in a row
- When "Clear Memory" was performed

#### 6. MALFUNCTION INDICATOR LIGHT CLEAR CONDITION

- When the OK driving cycle was completed 3 times in a row
- When "Clear Memory" was performed

#### 7. FAIL SAFE

None

#### 8. ECM OPERATION AT DTC

Memorize the freeze frame data. (For test mode \$02)

# DIAGNOSTIC TROUBLE CODE (DTC) DETECTING CRITERIA

GENERAL DESCRIPTION

## BM:DTC P0506 — IDLE CONTROL SYSTEM RPM LOWER THAN EXPECTED —

### 1. OUTLINE OF DIAGNOSIS

Detect the malfunction that the engine speed does not approach to the target engine speed at idling.  
Judge NG when the engine speed is lower than target engine speed and does not increase to target engine speed even though idle air control solenoid valve is opened.

### 2. COMPONENT DESCRIPTION

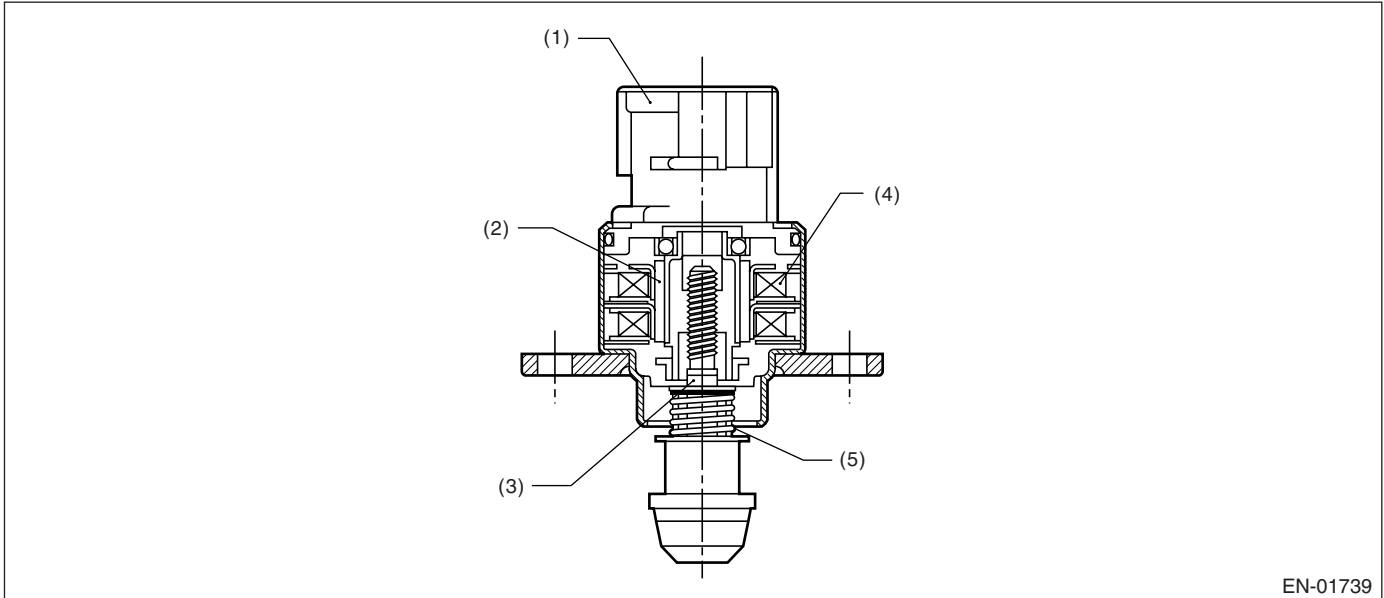

- (1) Connector
- (2) Permanent magnet
- (3) Shaft
- (4) Coil
- (5) Spring

### 3. ENABLE CONDITION

Secondary Parameters	Enable Conditions
Closed control in ISC	In operation
Dashpot function	0
Vehicle speed	= 0 km/h (0 MPH)
Coolant temperature	$\geq 75^{\circ}\text{C}$ ( $167^{\circ}\text{F}$ )
Battery voltage	$> 10.9\text{ V}$
AT model	"N" range or "P" range
MT model	Neutral

### 4. GENERAL DRIVE CYCLE

Perform the diagnosis continuously at idling after warming up engine.

# DIAGNOSTIC TROUBLE CODE (DTC) DETECTING CRITERIA

## GENERAL DESCRIPTION

---

### 5. DIAGNOSTIC METHOD

#### • Abnormality Judgment

Judge NG when the continuous time until completing all the malfunction criteria below becomes more than the time (10 seconds) needed for diagnosis.

#### Judgment Value

Malfunction Criteria	Threshold Value
Actual – target engine speed	≤ 100 rpm

**Time Needed for Diagnosis:** 10 seconds

**Malfunction Indicator Light Illumination:** Illuminates when malfunction occurs in 2 continuous driving cycles.

#### • Normality Judgment

Judge OK when the continuous time until completing the malfunction criteria below becomes more than time needed for diagnosis (2 seconds).

#### Judgment Value

Malfunction Criteria	Threshold Value
Actual – target engine speed	> 100 rpm

### 6. DTC CLEAR CONDITION

- When the OK idling cycle is completed 40 times in a row
- When “Clear Memory” was performed

### 7. MALFUNCTION INDICATOR LIGHT CLEAR CONDITION

- When the OK driving cycle was completed 3 times in a row
- When “Clear Memory” was performed

### 8. FAIL SAFE

None

### 9. ECM OPERATION AT DTC

Memorize the freeze frame data. (For test mode \$02)



# DIAGNOSTIC TROUBLE CODE (DTC) DETECTING CRITERIA

GENERAL DESCRIPTION

## BN:DTC P0507 — IDLE CONTROL SYSTEM RPM HIGHER THAN EXPECTED —

### 1. OUTLINE OF DIAGNOSIS

Detect the malfunction that the engine speed does not approach to the target engine speed at idling.  
Judge NG when the engine speed is higher than target engine speed and does not decrease to target engine speed even though idle air control solenoid valve is closed.

### 2. COMPONENT DESCRIPTION

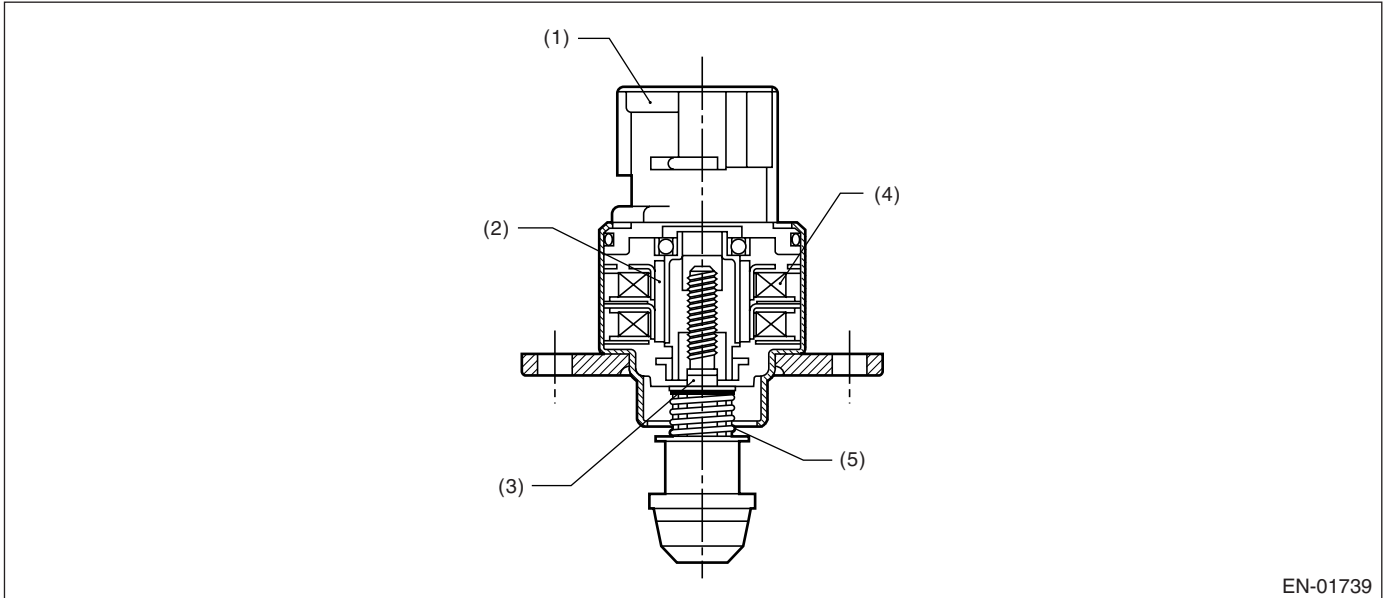

EN-01739

- (1) Connector
- (2) Permanent magnet
- (3) Shaft
- (4) Coil
- (5) Spring

### 3. ENABLE CONDITION

Secondary Parameters	Enable Conditions
Closed control in ISC	In operation
Dashpot function	0
Vehicle speed	= 0 km/h (0 MPH)
Coolant temperature	$\geq 75^{\circ}\text{C}$ ( $167^{\circ}\text{F}$ )
Battery voltage	$> 10.9\text{ V}$
AT model	"N" range or "P" range
MT model	Neutral

### 4. GENERAL DRIVE CYCLE

Perform the diagnosis continuously at idling after warming up engine.

# DIAGNOSTIC TROUBLE CODE (DTC) DETECTING CRITERIA

## GENERAL DESCRIPTION

---

### 5. DIAGNOSTIC METHOD

#### • Abnormality Judgment

Judge NG when the continuous time until completing all the malfunction criteria below becomes more than the time (10 seconds) needed for diagnosis.

#### Judgment Value

Malfunction Criteria	Threshold Value
Actual – target engine speed	≥ 200 rpm

**Time Needed for Diagnosis:** 10 seconds

**Malfunction Indicator Light Illumination:** Illuminates when malfunction occurs in 2 continuous driving cycles.

#### • Normality Judgment

Judge OK when the continuous time until completing all the malfunction criteria below becomes more than the time (2 seconds) needed for diagnosis.

#### Judgment Value

Malfunction Criteria	Threshold Value
Actual – target engine speed	< 200 rpm

### 6. DTC CLEAR CONDITION

- When the OK idling cycle is completed 40 times in a row
- When “Clear Memory” was performed

### 7. MALFUNCTION INDICATOR LIGHT CLEAR CONDITION

- When the OK driving cycle was completed 3 times in a row
- When “Clear Memory” was performed

### 8. FAIL SAFE

None

### 9. ECM OPERATION AT DTC

Memorize the freeze frame data. (For test mode \$02)

# DIAGNOSTIC TROUBLE CODE (DTC) DETECTING CRITERIA

GENERAL DESCRIPTION

## BO:DTC P0512 — STARTER REQUEST CIRCUIT —

### 1. OUTLINE OF DIAGNOSIS

- Detect the open/short circuit of starter switch.
- Judge ON NG when the starter signal remains OFF after engine start from stall.

### 2. ENABLE CONDITION

Secondary Parameters	Enable Conditions
Engine	Run

### 3. GENERAL DRIVING CYCLE

Always perform diagnosis continuously after starting engine.

### 4. DIAGNOSTIC METHOD

Judge NG when all condition are completed. Judge OK and clear NG when starter switch turned to ON.

#### Judgment Value

Malfunction Criteria	Threshold Value
Engine speed change	$\geq 0$ — 700 rpm
Vehicle speed	$\geq 0$ km/h (0 MPH)
Starter "ON" signal	Not detected

#### Time Needed for Diagnosis:

ON side                      1 second

**Malfunction Indicator Light Illumination:** Illuminates when malfunction occurs in 2 continuous driving cycles.

### 5. DTC CLEAR CONDITION

- When the OK idling cycle is completed 40 times in a row
- When "Clear Memory" was performed

### 6. MALFUNCTION INDICATOR LIGHT CLEAR CONDITION

- When the OK driving cycle was completed 3 times in a row
- When "Clear Memory" was performed

### 7. FAIL SAFE

None

### 8. ECM OPERATION AT DTC

Memorize the freeze frame data. (For test mode \$02)

# DIAGNOSTIC TROUBLE CODE (DTC) DETECTING CRITERIA

## GENERAL DESCRIPTION

### BP:DTC P0519 — IDLE CONTROL SYSTEM MALFUNCTION (FAIL-SAFE) —

#### 1. OUTLINE OF DIAGNOSIS

- Detect the malfunction of engine speed increase at idling.
- Judge NG when the engine speed is higher than and too far from the target engine speed.

#### 2. ENABLE CONDITION

Secondary Parameters	Enable Conditions
Dashpot function at closed idle control	0

#### 3. GENERAL DRIVE CYCLE

Always perform the diagnosis continuously at idle speed.

#### 4. DIAGNOSTIC METHOD

##### • Abnormality Judgment

Judge NG when the cumulative time until completing the malfunction criteria below becomes more than the time needed for diagnosis.

##### Judgment Value

Malfunction Criteria	Threshold Value
Actual – target engine speed	≥ 800 rpm
ISC closed loop compensation value	= MIN value

**Time Needed for Diagnosis:** 1 second

**Malfunction Indicator Light Illumination:** Illuminates as soon as malfunction occurs.

##### • Normality Judgment

Judge OK when one of the malfunction criteria below is completed.

##### Judgment Value

Malfunction Criteria	Threshold Value
ISC closed loop compensation value	≠ MIN value
Cumulative time (actual – target engine speed) < 100 rpm	≥ 2 seconds
Cumulative time (engine speed < target idle speed)	≥ 2 seconds

#### 5. DTC CLEAR CONDITION

- When the OK idling cycle is completed 40 times in a row
- When “Clear Memory” was performed

#### 6. MALFUNCTION INDICATOR LIGHT CLEAR CONDITION

- When the OK driving cycle was completed 3 times in a row
- When “Clear Memory” was performed

#### 7. FAIL SAFE

Cut the fuel of all cylinders, #1 cylinder or #1, #2 cylinder according to throttle position, engine speed, vehicle speed.

#### 8. ECM OPERATION AT DTC

Memorize the freeze frame data. (For test mode \$02)

# DIAGNOSTIC TROUBLE CODE (DTC) DETECTING CRITERIA

GENERAL DESCRIPTION

## BQ:DTC P0565 — CRUISE CONTROL ON SIGNAL —

### 1. OUTLINE OF DIAGNOSIS

Judge NG when the vehicle speed is less than 20 km/h (12 MPH) and cruise control set signal remains ON for limited time.

### 2. ENABLE CONDITION

Secondary Parameters	Enable Conditions
Vehicle speed	≤ 20 km/h (12 MPH)

### 3. GENERAL DRIVING CYCLE

Perform the diagnosis with less than 20 km/h (12 MPH) vehicle speed.

### 4. DIAGNOSTIC METHOD

#### Judgment Value

Malfunction Criteria	Threshold Value
Canceling signal	No signal

**Time Needed for Diagnosis:** 10 seconds

**Malfunction Indicator Light Illumination:** Illuminates when malfunction occurs in 2 continuous driving cycles.

### 5. DTC CLEAR CONDITION

- When the OK idling cycle was completed 40 times in a row
- When "Clear Memory" was performed

### 6. MALFUNCTION INDICATOR LIGHT CLEAR CONDITION

- When the OK driving cycle was completed 3 times in a row
- When "Clear Memory" was performed

### 7. FAIL SAFE

None

### 8. ECM OPERATION AT DTC SETTING

Memorize the freeze frame data. (For test mode \$02)

# DIAGNOSTIC TROUBLE CODE (DTC) DETECTING CRITERIA

## GENERAL DESCRIPTION

---

### **BR:DTC P0604 — INTERNAL CONTROL MODULE RANDOM ACCESS MEMORY (RAM) ERROR —**

#### **1. OUTLINE OF DIAGNOSIS**

- Detect the malfunction of micro-computer (RAM).
- Zero clear the all normal RAM on initial routine, and judge NG when the sum of cleared RAM is not “0”.

#### **2. ENABLE CONDITION**

Perform the diagnosis without condition by initial routine.

#### **3. GENERAL DRIVING CYCLE**

Perform the diagnosis only once immediately after the IG key is turned to ON.

#### **4. DIAGNOSTIC METHOD**

Judge NG when the malfunction criteria below are completed, and judge OK at the IG key turned to ON.

##### **Judgment Value**

Malfunction Criteria	Threshold Value
Sum on RAM data after data cleared operation	Not to zero

**Time Needed for Diagnosis:** Not determined

**Malfunction Indicator Light Illumination:** Illuminates as soon as malfunction occurs.

#### **5. DTC CLEAR CONDITION**

- When the OK idling cycle is completed 40 times in a row
- When “Clear Memory” was performed

#### **6. MALFUNCTION INDICATOR LIGHT CLEAR CONDITION**

- When the OK driving cycle is completed 3 times in a row
- When “Clear Memory” was performed

#### **7. FAIL SAFE**

None

#### **8. ECM OPERATION AT DTC SETTING**

Memorize the freeze frame data. (For test mode \$02)

# DIAGNOSTIC TROUBLE CODE (DTC) DETECTING CRITERIA

GENERAL DESCRIPTION

## BS:DTC P0691 — COOLING FAN 1 CONTROL CIRCUIT LOW —

### 1. OUTLINE OF DIAGNOSIS

- Detect the open/short circuit of radiator fan circuit.
- Judge NG when the ECM output level and the actual terminal level are different.

### 2. ENABLE CONDITION

Secondary Parameters	Enable Conditions
Engine speed	≥ 500 rpm
Battery voltage	≥ 8 V
After engine starting	1 second or more
Ignition switch	ON

### 3. GENERAL DRIVING CYCLE

Always perform the diagnosis continuously after starting the engine.

### 4. DIAGNOSTIC METHOD

Judge NG when the continuous time until completing the malfunction criteria below becomes more than the time (2.5 seconds) needed for diagnosis, and also judge OK when the malfunction criteria below is not completed. And then clear NG.

#### Judgment Value

Malfunction Criteria	Threshold Value
Terminal voltage level when ECM transmits OFF signal	Low level

**Time Needed for Diagnosis:** 2.5 seconds

**Malfunction Indicator Light Illumination:** Illuminates when malfunction occurs in 2 continuous driving cycles.

### 5. DTC CLEAR CONDITION

- When the OK idling cycle was completed 40 times in a row
- When “Clear Memory” was performed

### 6. MALFUNCTION INDICATOR LIGHT CLEAR CONDITION

- When the OK driving cycle was completed 3 times in a row
- When “Clear Memory” was performed

### 7. FAIL SAFE

None

### 8. ECM OPERATION AT DTC SETTING

Memorize the freeze frame data. (For test mode \$02)

# DIAGNOSTIC TROUBLE CODE (DTC) DETECTING CRITERIA

## GENERAL DESCRIPTION

---

### BT:DTC P0692 — COOLING FAN 1 CONTROL CIRCUIT HIGH —

#### 1. OUTLINE OF DIAGNOSIS

- Detect the open/short circuit of radiator fan circuit.
- Judge NG when the ECM output level and the actual terminal level are different.

#### 2. ENABLE CONDITION

Secondary Parameters	Enable Conditions
Engine speed	≥ 500 rpm
Battery voltage	≥ 8 V
After engine starting	1 second or more
Ignition switch	ON

#### 3. GENERAL DRIVING CYCLE

Always perform the diagnosis continuously after starting the engine.

#### 4. DIAGNOSTIC METHOD

Judge NG when the continuous time until completing the malfunction criteria below becomes more than the time (2.5 seconds) needed for diagnosis, and also judge OK when the malfunction criteria below is not completed. And then clear NG.

##### Judgment Value

Malfunction Criteria	Threshold Value
Terminal voltage level when ECM transmits ON signal	High level

**Time Needed for Diagnosis:** 2.5 seconds

**Malfunction Indicator Light Illumination:** Illuminates when malfunction occurs in 2 continuous driving cycles.

#### 5. DTC CLEAR CONDITION

- When the OK idling cycle was completed 40 times in a row
- When “Clear Memory” was performed

#### 6. MALFUNCTION INDICATOR LIGHT CLEAR CONDITION

- When the OK driving cycle was completed 3 times in a row
- When “Clear Memory” was performed

#### 7. FAIL SAFE

None

#### 8. ECM OPERATION AT DTC SETTING

Memorize the freeze frame data. (For test mode \$02)



# DIAGNOSTIC TROUBLE CODE (DTC) DETECTING CRITERIA

GENERAL DESCRIPTION

## BU:DTC P0703 — TORQUE CONVERTER/BRAKE SWITCH “B” CIRCUIT —

### 1. OUTLINE OF DIAGNOSIS

Judge NG when the AT break SW circuit is battery short, ground short or open.

### 2. ENABLE CONDITION

Secondary Parameters	Enable Conditions
Vehicle speed change	30 to 0 km/h (18.6 to 0 MPH) 0 to 30 km/h (0 to 18.6 MPH)

### 3. GENERAL DRIVING CYCLE

Perform the diagnosis with vehicle speed change from 30 to 0 km/h (from 18.6 to 0 MPH) and change from 0 to 30 km/h (from 0 to 18.6 MPH).

### 4. DIAGNOSTIC METHOD

#### Judgment Value

Malfunction Criteria	Threshold Value
ON signal	No signal
OFF signal	No signal

**Time Needed for Diagnosis:** 15 times

**Malfunction Indicator Light Illumination:** Illuminates when malfunction occurs in 2 continuous driving cycles.

### 5. DTC CLEAR CONDITION

- When the OK idling cycle was completed 40 times in a row
- When “Clear Memory” was performed

### 6. MALFUNCTION INDICATOR LIGHT CLEAR CONDITION

- When the OK driving cycle was completed 3 times in a row
- When “Clear Memory” was performed

### 7. FAIL SAFE

None

### 8. ECM OPERATION AT DTC SETTING

Memorize the freeze frame data. (For test mode \$02)

# DIAGNOSTIC TROUBLE CODE (DTC) DETECTING CRITERIA

## GENERAL DESCRIPTION

### BV:DTC P0705 — TRANSMISSION RANGE SENSOR CIRCUIT (PRNDL INPUT)

#### 1. OUTLINE OF DIAGNOSIS

Judge NG when the “D” range switch becomes ground short or open circuit.

#### 2. COMPONENT DESCRIPTION

Inhibitor switch ensures the safety at engine start. This switch is installed to the right side of transmission case, and operated by selector lever.

When the selector lever is in the “P” or “N” range, the engine will start because the electric circuit in inhibitor switch is closed and the starter circuit is connected.

When the selector lever is in the “R”, “D”, “3”, “2” or “1” range, the electric circuit in inhibitor switch is open; therefore, the engine cannot be cranked.

In the “R” range, the back-up light will illuminate because the back-up light circuit in the switch is connected. In addition to the functions above, the inhibitor switch has the circuit which detects the selected range position at the present and transmits the range signal to the TCM.

#### 3. ENABLE CONDITION

##### • Enable condition A

Secondary Parameters	Enable Conditions
Shift	“N” to “3”
Vehicle speed	≥ 60 km/h (37 MPH)

##### • Enable condition B

Secondary Parameters	Enable Conditions
Engine speed	> 500 rpm
Battery voltage	> 10.9 V

#### 4. GENERAL DRIVING CYCLE

- Perform the diagnosis continuously after engine start (Under enable condition A).
- Perform the diagnosis when shift from “N” to “3” range, at more than 60 km/h (37 MPH) (Under enable condition B).

#### 5. DIAGNOSTIC METHOD

##### Judgment Value

Malfunction Criteria	Threshold Value
“D” signal continuously (Under enable condition A)	Not detected
Simultaneous signal (Under enable condition B)	≥ 2

##### Time Needed for Diagnosis:

- 63.75 seconds (Under enable condition A)
- 10 seconds (Under enable condition B)

**Malfunction Indicator Light Illumination:** Illuminates when malfunction occurs in 2 continuous driving cycles.

#### 6. DTC CLEAR CONDITION

- When the OK idling cycle was completed 40 times in a row
- When “Clear Memory” was performed

#### 7. MALFUNCTION INDICATOR LIGHT CLEAR CONDITION

- When the OK driving cycle was completed 3 times in a row
- When “Clear Memory” was performed

# DIAGNOSTIC TROUBLE CODE (DTC) DETECTING CRITERIA

GENERAL DESCRIPTION

---

## 8. FAIL SAFE

None

## 9. ECM OPERATION AT DTC SETTING

Memorize the freeze frame data. (For test mode \$02)

# DIAGNOSTIC TROUBLE CODE (DTC) DETECTING CRITERIA

## GENERAL DESCRIPTION

### BW:DTC P0710 — TRANSMISSION FLUID TEMPERATURE SENSOR CIRCUIT

#### 1. OUTLINE OF DIAGNOSIS

- Judge NG when the ATF temperature sensor is open, battery short or ground short.
- Judge NG when the ATF sensor is defective.

#### 2. COMPONENT DESCRIPTION

ATF temperature sensor is installed to the hydraulic control valve body of transmission as a unit with transmission harness. This sensor detects ATF temperature and outputs it as electric resistance signal.

#### 3. ENABLE CONDITION

Secondary Parameters	Enable Conditions
None	

#### 4. GENERAL DRIVING CYCLE

Always perform the diagnosis continuously.

#### 5. DIAGNOSTIC METHOD

##### Judgment Value

Malfunction Criteria	Threshold Value
Output voltage	$\leq 0.1 \text{ V}$
Output at $\geq 80\text{km/h}$ (50 MPH) after 5 minutes from reaching more than 4.8 V	$\geq 4.7 \text{ V}$

**Time Needed for Diagnosis:** 63.75 seconds

**Malfunction Indicator Light Illumination:** Illuminates when malfunction occurs in 2 continuous driving cycles.

#### 6. DTC CLEAR CONDITION

- When the OK idling cycle was completed 40 times in a row
- When "Clear Memory" was performed

#### 7. MALFUNCTION INDICATOR LIGHT CLEAR CONDITION

- When the OK driving cycle was completed 3 times in a row
- When "Clear Memory" was performed

#### 8. FAIL SAFE

Control ATF temperature at a constant temperature 80°C (176°F).

#### 9. ECM OPERATION AT DTC SETTING

Memorize the freeze frame data. (For test mode \$02)

# DIAGNOSTIC TROUBLE CODE (DTC) DETECTING CRITERIA

GENERAL DESCRIPTION

## **BX:DTC P0716 — INPUT/TURBINE SPEED SENSOR CIRCUIT RANGE/PERFORMANCE —**

### **1. OUTLINE OF DIAGNOSIS**

Judge NG when the turbine speed signal is not transmitted for some reasons.

### **2. COMPONENT DESCRIPTION**

Torque converter turbine speed sensor (output shaft speed sensor) is installed to the outside of transmission case.

This sensor detects the turbine speed of torque converter by the peripheral speed of high clutch drum connected to input shaft. And then it transmits the sine wave signal (32 pulses per rev.) to TCM. TCM calculates the ratio of the input shaft speed to vehicle speed, and then makes a judgment whether to shift or not.

### **3. ENABLE CONDITION**

Secondary Parameters	Enable Conditions
Engine speed	≥ 1,500 rpm
Vehicle speed	≥ 40 km/h (25 MPH)
Range switch	"D", "3", "2" or "1"

### **4. GENERAL DRIVING CYCLE**

Perform the diagnosis at engine speed more than 1500 rpm and vehicle speed more than 40 km/h (25 MPH).

### **5. DIAGNOSTIC METHOD**

Perform the diagnosis when the conditions below were continued for 2 seconds.

- (1) Except "P", "N", "R" ranges and inhibitor switch is normal.
- (2) Engine speed is more than 3,000 rpm.
- (3) Vehicle speed is 30 km/h (19 MPH) and vehicle speed sensor is normal.
- (4) Turbine speed is more than 600 rpm.

#### **Judgment Value**

Malfunction Criteria	Threshold Value
Output from turbine shaft speed	< 600 rpm

**Time Needed for Diagnosis:** As soon as the malfunction occurs.

**Malfunction Indicator Light Illumination:** Illuminates when malfunction occurs in 2 continuous driving cycles.

### **6. DTC CLEAR CONDITION**

- When the OK idling cycle was completed 40 times in a row
- When "Clear Memory" was performed

### **7. MALFUNCTION INDICATOR LIGHT CLEAR CONDITION**

- When the OK driving cycle was completed 3 times in a row
- When "Clear Memory" was performed

### **8. FAIL SAFE**

None

### **9. ECM OPERATION AT DTC SETTING**

Memorize the freeze frame data. (For test mode \$02)

# DIAGNOSTIC TROUBLE CODE (DTC) DETECTING CRITERIA

## GENERAL DESCRIPTION

---

### BY:DTC P0720 — OUTPUT SPEED SENSOR CIRCUIT —

#### 1. OUTLINE OF DIAGNOSIS

Judge NG when an abnormal large signal is input to the front vehicle speed sensor, or no signal is input to the rear vehicle speed sensor.

#### 2. COMPONENT DESCRIPTION

This vehicle speed sensor (output shaft speed sensor) is installed to the outside of transmission case. This sensor detects the front wheel speed, and transmits the sine wave signal (16 pulses per rev.) to TCM. TCM converts the signal to pulse signal, and transmits to both of the ECM and the combination meter.

#### 3. ENABLE CONDITION

Secondary Parameters	Enable Conditions
Vehicle speed	≥ 20 km/h (12 MPH)

#### 4. GENERAL DRIVING CYCLE

Perform the diagnosis continuously with more than 20 km/h (12 MPH) vehicle speed.

#### 5. DIAGNOSTIC METHOD

##### Judgment Value

Malfunction Criteria	Threshold Value
Vehicle speed sensor signals/1second	≥ 4698 or no signal

**Time Needed for Diagnosis:** 63.75 seconds

**Malfunction Indicator Light Illumination:** Illuminates when malfunction occurs in 2 continuous driving cycles.

#### 6. DTC CLEAR CONDITION

- When the OK idling cycle was completed 40 times in a row
- When "Clear Memory" was performed

#### 7. MALFUNCTION INDICATOR LIGHT CLEAR CONDITION

- When the OK driving cycle was completed 3 times in a row
- When "Clear Memory" was performed

#### 8. FAIL SAFE

- Use the normal vehicle speed sensor signal when either of them is normal.
- Use the vehicle speed calculated from the current gear position and turbine speed when both front and rear wheels are troubled.

#### 9. ECM OPERATION AT DTC SETTING

Memorize the freeze frame data. (For test mode \$02)

# DIAGNOSTIC TROUBLE CODE (DTC) DETECTING CRITERIA

GENERAL DESCRIPTION

## BZ:DTC P0726 — ENGINE SPEED INPUT CIRCUIT RANGE/PERFORMANCE —

### 1. OUTLINE OF DIAGNOSIS

Judge NG when the engine speed is not input in the status of running the engine.

### 2. COMPONENT DESCRIPTION

Engine speed sensor is installed to the outside of engine body and crank part. This sensor detects the crank speed, and transmits the sine wave signal (2 pulses per rev.) to TCM.

### 3. ENABLE CONDITION

Secondary Parameters	Enable Conditions
Output from mass air flow sensor	$\geq 1.0$ V

### 4. GENERAL DRIVING CYCLE

Perform the diagnosis continuously after engine start.

### 5. DIAGNOSTIC METHOD

#### Judgment Value

Malfunction Criteria	Threshold Value
Engine speed	$\leq 400$ rpm

**Time Needed for Diagnosis:** 63.75 seconds

**Malfunction Indicator Light Illumination:** Illuminates when malfunction occurs in 2 continuous driving cycles.

### 6. DTC CLEAR CONDITION

- When the OK idling cycle was completed 40 times in a row
- When "Clear Memory" was performed

### 7. MALFUNCTION INDICATOR LIGHT CLEAR CONDITION

- When the OK driving cycle was completed 3 times in a row
- When "Clear Memory" was performed

### 8. FAIL SAFE

None

### 9. ECM OPERATION AT DTC SETTING

Memorize the freeze frame data. (For test mode \$02)

# DIAGNOSTIC TROUBLE CODE (DTC) DETECTING CRITERIA

## GENERAL DESCRIPTION

### CA:DTC P0731 — GEAR 1 INCORRECT RATIO —

#### 1. OUTLINE OF DIAGNOSIS

Judge NG when the expected present gear is different from the actual gear.

#### 2. ENABLE CONDITION

Secondary Parameters	Enable Conditions
Throttle angle	≥ 15°
Vehicle speed	≥ 10 km/h (6 MPH)
Range switch	“D”, “3”, “2” or “1”
Upshift or downshift events	Not in operation

#### 3. GENERAL DRIVING CYCLE

Perform the diagnosis continuously with more than 10 km/h (6 MPH) vehicle speed and depressing accelerator pedal.

#### 4. DIAGNOSTIC METHOD

Perform the diagnosis when the conditions below are not completed for more than 40 milliseconds on normal control.

- (1) Vehicle speed is more than 10 km/h (6 MPH).
- (2) Throttle sensor is more than a certain angle.
- (3) Shifted to “D”, “3”, “2” or “1” range, and range signal is normal.
- (4) More than 1 second passed after shift change finished.

#### Judgment Value

Malfunction Criteria	Threshold Value
GR / (1st gear ratio) Where, GR = (vehicle speed sensor 1 output) / (turbine shaft speed sensor output)	> 110% or < 90%

**Time Needed for Diagnosis:** 3 seconds

**Malfunction Indicator Light Illumination:** Illuminates when malfunction occurs in 2 continuous driving cycles.

#### 5. DTC CLEAR CONDITION

- When the OK idling cycle was completed 40 times in a row
- When “Clear Memory” was performed

#### 6. MALFUNCTION INDICATOR LIGHT CLEAR CONDITION

- When the OK driving cycle was completed 3 times in a row
- When “Clear Memory” was performed

#### 7. FAIL SAFE

None

#### 8. ECM OPERATION AT DTC SETTING

Memorize the freeze frame data. (For test mode \$02)



# DIAGNOSTIC TROUBLE CODE (DTC) DETECTING CRITERIA

GENERAL DESCRIPTION

## CB:DTC P0732 — GEAR 2 INCORRECT RATIO —

### 1. OUTLINE OF DIAGNOSIS

Judge NG when the expected present gear is different from the actual gear.

### 2. ENABLE CONDITION

Secondary Parameters	Enable Conditions
Throttle angle	$\geq 15^\circ$
Vehicle speed	$\geq 10$ km/h (6 MPH)
Range switch	"D", "3", "2" or "1"
Upshift or downshift events	Not in operation

### 3. GENERAL DRIVING CYCLE

Perform the diagnosis continuously with more than 10 km/h (6 MPH) vehicle speed and depressing accelerator pedal.

### 4. DIAGNOSTIC METHOD

Perform the diagnosis when the conditions below are not completed for more than 40 milliseconds on normal control.

- (1) Vehicle speed is more than 10 km/h (6 MPH).
- (2) Throttle sensor is more than a certain angle.
- (3) Shifted to "D", "3", "2" or "1" range, and range signal is normal.
- (4) More than 1 second passed after shift change finished.

#### Judgment Value

Malfunction Criteria	Threshold Value
GR / (2nd gear ratio) Where, GR = (vehicle speed sensor 1 output) / (turbine shaft speed sensor output)	> 110% or < 90%

**Time Needed for Diagnosis:** 3 seconds

**Malfunction Indicator Light Illumination:** Illuminates when malfunction occurs in 2 continuous driving cycles.

### 5. DTC CLEAR CONDITION

- When the OK idling cycle was completed 40 times in a row
- When "Clear Memory" was performed

### 6. MALFUNCTION INDICATOR LIGHT CLEAR CONDITION

- When the OK driving cycle was completed 3 times in a row
- When "Clear Memory" was performed

### 7. FAIL SAFE

None

### 8. ECM OPERATION AT DTC SETTING

Memorize the freeze frame data. (For test mode \$02)

# DIAGNOSTIC TROUBLE CODE (DTC) DETECTING CRITERIA

## GENERAL DESCRIPTION

### CC:DTC P0733 — GEAR 3 INCORRECT RATIO —

#### 1. OUTLINE OF DIAGNOSIS

Judge NG when the expected present gear is different from the actual gear.

#### 2. ENABLE CONDITION

Secondary Parameters	Enable Conditions
Throttle angle	$\geq 15^\circ$
Vehicle speed	$\geq 10$ km/h (6 MPH)
Range switch	"D", "3", "2" or "1"
Upshift or downshift events	Not in operation

#### 3. GENERAL DRIVING CYCLE

Perform the diagnosis continuously with more than 10 km/h (6 MPH) vehicle speed and depressing accelerator pedal.

#### 4. DIAGNOSTIC METHOD

Perform the diagnosis when the conditions below are not completed for more than 40 milliseconds on normal control.

- (1) Vehicle speed is more than 10 km/h (6 MPH).
- (2) Throttle sensor is more than a certain angle.
- (3) Shifted to "D", "3", "2" or "1" range, and range signal is normal.
- (4) More than 1 second passed after shift change finished.

#### Judgment Value

Malfunction Criteria	Threshold Value
GR / (3rd gear ratio) Where, GR = (vehicle speed sensor 1 output) / (turbine shaft speed sensor output)	> 110% or < 90%

**Time Needed for Diagnosis:** 3 seconds

**Malfunction Indicator Light Illumination:** Illuminates when malfunction occurs in 2 continuous driving cycles.

#### 5. DTC CLEAR CONDITION

- When the OK idling cycle was completed 40 times in a row
- When "Clear Memory" was performed

#### 6. MALFUNCTION INDICATOR LIGHT CLEAR CONDITION

- When the OK driving cycle was completed 3 times in a row
- When "Clear Memory" was performed

#### 7. FAIL SAFE

None

#### 8. ECM OPERATION AT DTC SETTING

Memorize the freeze frame data. (For test mode \$02)

# DIAGNOSTIC TROUBLE CODE (DTC) DETECTING CRITERIA

GENERAL DESCRIPTION

## CD:DTC P0734 — GEAR 4 INCORRECT RATIO —

### 1. OUTLINE OF DIAGNOSIS

Judge NG when the expected present gear is different from the actual gear.

### 2. ENABLE CONDITION

Secondary Parameters	Enable Conditions
Throttle angle	$\geq 15^\circ$
Vehicle speed	$\geq 10$ km/h (6 MPH)
Range switch	"D", "3", "2" or "1"
Upshift or downshift events	Not in operation

### 3. GENERAL DRIVING CYCLE

Perform the diagnosis continuously with more than 10 km/h (6 MPH) vehicle speed and depressing accelerator pedal.

### 4. DIAGNOSTIC METHOD

Perform the diagnosis when the conditions below are not completed for more than 40 milliseconds on normal control.

- (1) Vehicle speed is more than 10 km/h (6 MPH).
- (2) Throttle sensor is more than a certain angle.
- (3) Shifted to "D", "3", "2" or "1" range, and range signal is normal.
- (4) More than 1 second passed after shift change finished.

#### Judgment Value

Malfunction Criteria	Threshold Value
GR / (4th gear ratio) Where, GR = (vehicle speed sensor 1 output) / (turbine shaft speed sensor output)	> 110% or < 90%

**Time Needed for Diagnosis:** 3 seconds

**Malfunction Indicator Light Illumination:** Illuminates when malfunction occurs in 2 continuous driving cycles.

### 5. DTC CLEAR CONDITION

- When the OK idling cycle was completed 40 times in a row
- When "Clear Memory" was performed

### 6. MALFUNCTION INDICATOR LIGHT CLEAR CONDITION

- When the OK driving cycle was completed 3 times in a row
- When "Clear Memory" was performed

### 7. FAIL SAFE

None

### 8. ECM OPERATION AT DTC SETTING

Memorize the freeze frame data. (For test mode \$02)

# DIAGNOSTIC TROUBLE CODE (DTC) DETECTING CRITERIA

## GENERAL DESCRIPTION

---

### CE:DTC P0741 — TORQUE CONVERTER CLUTCH CIRCUIT PERFORMANCE OR STUCK OFF —

#### 1. OUTLINE OF DIAGNOSIS

Judge NG when the engine speed is different from the turbine speed for some reasons at AT lock-up.

#### 2. ENABLE CONDITION

Secondary Parameters	Enable Conditions
In 4th gear position, duty ratio for duty solenoid valve	$\geq 90\%$

#### 3. GENERAL DRIVING CYCLE

Perform the diagnosis when AT lock-up with 4th gear.

#### 4. DIAGNOSTIC METHOD

##### Judgment Value

Malfunction Criteria	Threshold Value
Engine speed $\geq$ (output shaft speed $\times$ 4th gear ratio $\times 9/8$ )	

**Time Needed for Diagnosis:** 10.2 seconds

**Malfunction Indicator Light Illumination:** Illuminates when malfunction occurs in 2 continuous driving cycles.

#### 5. DTC CLEAR CONDITION

- When the OK idling cycle was completed 40 times in a row
- When "Clear Memory" was performed

#### 6. MALFUNCTION INDICATOR LIGHT CLEAR CONDITION

- When the OK driving cycle was completed 3 times in a row
- When "Clear Memory" was performed

#### 7. FAIL SAFE

Not allowed to lock up.

#### 8. ECM OPERATION AT DTC SETTING

Memorize the freeze frame data. (For test mode \$02)

# DIAGNOSTIC TROUBLE CODE (DTC) DETECTING CRITERIA

GENERAL DESCRIPTION

## CF:DTC P0743 — TORQUE CONVERTER CLUTCH CIRCUIT ELECTRICAL —

### 1. OUTLINE OF DIAGNOSIS

Judge NG when the lock-up duty solenoid becomes battery short, ground short or open circuit.

### 2. COMPONENT DESCRIPTION

Lock-up duty solenoid is installed to the transmission hydraulic control valve body. The duty ratio is controlled by the signal from TCM. This allows the lock-up clutch to be connected or released smoothly by controlling the lock-up control valve.

### 3. ENABLE CONDITION

Secondary Parameters	Enable Conditions
None	

### 4. GENERAL DRIVING CYCLE

Always perform the diagnosis continuously.

### 5. DIAGNOSTIC METHOD

#### Judgment Value

Malfunction Criteria	Threshold Value
Vc at "ON" signal from ECM	Low level
Vc at "OFF" signal from ECM	High level

**Time Needed for Diagnosis:** 0.14 seconds

**Malfunction Indicator Light Illumination:** Illuminates when malfunction occurs in 2 continuous driving cycles.

### 6. DTC CLEAR CONDITION

- When the OK idling cycle was completed 40 times in a row
- When "Clear Memory" was performed

### 7. MALFUNCTION INDICATOR LIGHT CLEAR CONDITION

- When the OK driving cycle was completed 3 times in a row
- When "Clear Memory" was performed

### 8. FAIL SAFE

None

### 9. ECM OPERATION AT DTC SETTING

Memorize the freeze frame data. (For test mode \$02)

# DIAGNOSTIC TROUBLE CODE (DTC) DETECTING CRITERIA

## GENERAL DESCRIPTION

---

### CG:DTC P0748 — PRESSURE CONTROL SOLENOID “A” ELECTRICAL —

#### 1. OUTLINE OF DIAGNOSIS

Judge NG when the line pressure duty solenoid becomes battery short, ground short or open circuit.

#### 2. COMPONENT DESCRIPTION

Line pressure duty solenoid is installed to the transmission hydraulic control valve body. The duty ratio is controlled by the signal from TCM. This allows controlling the pressure modifier valve and accumulator control valve A, and allows the line pressure to be adjusted to the pressure appropriate for driving condition.

#### 3. ENABLE CONDITION

Secondary Parameters	Enable Conditions
None	

#### 4. GENERAL DRIVING CYCLE

Always perform the diagnosis continuously.

#### 5. DIAGNOSTIC METHOD

##### Judgment Value

Malfunction Criteria	Threshold Value
Vc at “ON” signal from ECM	Low level
Vc at “OFF” signal from ECM	High level

**Time Needed for Diagnosis:** 0.14 seconds

**Malfunction Indicator Light Illumination:** Illuminates when malfunction occurs in 2 continuous driving cycles.

#### 6. DTC CLEAR CONDITION

- When the OK idling cycle was completed 40 times in a row
- When “Clear Memory” was performed

#### 7. MALFUNCTION INDICATOR LIGHT CLEAR CONDITION

- When the OK driving cycle was completed 3 times in a row
- When “Clear Memory” was performed

#### 8. FAIL SAFE

Control the shift to be fixed in 3rd gear.

#### 9. ECM OPERATION AT DTC SETTING

Memorize the freeze frame data. (For test mode \$02)

# DIAGNOSTIC TROUBLE CODE (DTC) DETECTING CRITERIA

GENERAL DESCRIPTION

## CH:DTC P0753 — SHIFT SOLENOID “A” ELECTRICAL —

### 1. OUTLINE OF DIAGNOSIS

Judge NG when the shift solenoid 1 becomes battery short, ground short or open circuit.

### 2. COMPONENT DESCRIPTION

Shift solenoid 1

Shift solenoid is installed to the transmission hydraulic control valve body. This solenoid is switched on or off by the signal from TCM. Gear positions will change depending on the solenoid condition which is ON or OFF.

### 3. ENABLE CONDITION

Secondary Parameters	Enable Conditions
None	

### 4. GENERAL DRIVING CYCLE

Always perform the diagnosis continuously.

### 5. DIAGNOSTIC METHOD

#### Judgment Value

Malfunction Criteria	Threshold Value
Collector voltage of transistor (Vc) for solenoid valve is inconsistent with signal from ECM	

**Time Needed for Diagnosis:** 30 milliseconds

**Malfunction Indicator Light Illumination:** Illuminates when malfunction occurs in 2 continuous driving cycles.

### 6. DTC CLEAR CONDITION

- When the OK idling cycle was completed 40 times in a row
- When “Clear Memory” was performed

### 7. MALFUNCTION INDICATOR LIGHT CLEAR CONDITION

- When the OK driving cycle was completed 3 times in a row
- When “Clear Memory” was performed

### 8. FAIL SAFE

Control the shift to be fixed in 3rd gear.

### 9. ECM OPERATION AT DTC SETTING

Memorize the freeze frame data. (For test mode \$02)

# DIAGNOSTIC TROUBLE CODE (DTC) DETECTING CRITERIA

## GENERAL DESCRIPTION

---

### CI: DTC P0758 — SHIFT SOLENOID “B” ELECTRICAL —

#### 1. OUTLINE OF DIAGNOSIS

Judge NG when the shift solenoid 2 becomes battery short, ground short or open circuit.

#### 2. COMPONENT DESCRIPTION

Shift solenoid 2

Shift solenoid is installed to the transmission hydraulic control valve body. This solenoid is switched on or off by the signal from TCM. Gear positions will change depending on the solenoid condition which is ON or OFF.

#### 3. ENABLE CONDITION

Secondary Parameters	Enable Conditions
None	

#### 4. GENERAL DRIVING CYCLE

Always perform the diagnosis continuously.

#### 5. DIAGNOSTIC METHOD

##### Judgment Value

Malfunction Criteria	Threshold Value
Vc for solenoid valve is inconsistent with signal from ECM	

**Time Needed for Diagnosis:** 30 milliseconds

**Malfunction Indicator Light Illumination:** Illuminates when malfunction occurs in 2 continuous driving cycles.

#### 6. DTC CLEAR CONDITION

- When the OK idling cycle was completed 40 times in a row
- When “Clear Memory” was performed

#### 7. MALFUNCTION INDICATOR LIGHT CLEAR CONDITION

- When the OK driving cycle was completed 3 times in a row
- When “Clear Memory” was performed

#### 8. FAIL SAFE

Control the shift to be fixed in 3rd gear.

#### 9. ECM OPERATION AT DTC SETTING

Memorize the freeze frame data. (For test mode \$02)



# DIAGNOSTIC TROUBLE CODE (DTC) DETECTING CRITERIA

GENERAL DESCRIPTION

## CJ:DTC P0771 — SHIFT SOLENOID “E” PERFORMANCE OR STUCK OFF —

### 1. OUTLINE OF DIAGNOSIS

Judge NG when the low clutch timing solenoid becomes battery short, ground short or open circuit.

### 2. COMPONENT DESCRIPTION

Low clutch timing solenoid

Low clutch timing solenoid is installed to the transmission hydraulic control valve body. This solenoid is switched on or off by the signal from TCM. This allows controlling the low clutch timing valve B and reverse inhibitor valve.

### 3. ENABLE CONDITION

Secondary Parameters	Enable Conditions
None	

### 4. GENERAL DRIVING CYCLE

Always perform the diagnosis continuously.

### 5. DIAGNOSTIC METHOD

#### Judgment Value

Malfunction Criteria	Threshold Value
Vc at “ON” signal from ECM	Low level
Vc at “OFF” signal from ECM	High level

**Time Needed for Diagnosis:** 30 milliseconds

**Malfunction Indicator Light Illumination:** Illuminates when malfunction occurs in 2 continuous driving cycles.

### 6. DTC CLEAR CONDITION

- When the OK idling cycle was completed 40 times in a row
- When “Clear Memory” was performed

### 7. MALFUNCTION INDICATOR LIGHT CLEAR CONDITION

- When the OK driving cycle was completed 3 times in a row
- When “Clear Memory” was performed

### 8. FAIL SAFE

None

### 9. ECM OPERATION AT DTC SETTING

Memorize the freeze frame data. (For test mode \$02)

# DIAGNOSTIC TROUBLE CODE (DTC) DETECTING CRITERIA

## GENERAL DESCRIPTION

---

### CK:DTC P0778 — PRESSURE CONTROL SOLENOID “B” ELECTRICAL —

#### 1. OUTLINE OF DIAGNOSIS

Judge NG when the 2-4 brake duty solenoid becomes battery short, ground short or open circuit.

#### 2. COMPONENT DESCRIPTION

2-4 brake duty solenoid is installed to the transmission hydraulic control valve body. The duty ratio is controlled by the signal from TCM. This solenoid decreases the change gear shock by adjusting the 2-4 brake pressure during 2-4 brake operation.

#### 3. ENABLE CONDITION

Secondary Parameters	Enable Conditions
None	

#### 4. GENERAL DRIVING CYCLE

Always perform the diagnosis continuously.

#### 5. DIAGNOSTIC METHOD

##### Judgment Value

Malfunction Criteria	Threshold Value
Vc at “ON” signal from ECM	Low level
Vc at “OFF” signal from ECM	High level

**Time Needed for Diagnosis:** 0.14 seconds

**Malfunction Indicator Light Illumination:** Illuminates when malfunction occurs in 2 continuous driving cycles.

#### 6. DTC CLEAR CONDITION

- When the OK idling cycle was completed 40 times in a row
- When “Clear Memory” was performed

#### 7. MALFUNCTION INDICATOR LIGHT CLEAR CONDITION

- When the OK driving cycle was completed 3 times in a row
- When “Clear Memory” was performed

#### 8. FAIL SAFE

Control the shift to be fixed in 3rd gear.

#### 9. ECM OPERATION AT DTC SETTING

Memorize the freeze frame data. (For test mode \$02)

# DIAGNOSTIC TROUBLE CODE (DTC) DETECTING CRITERIA

GENERAL DESCRIPTION

## CL:DTC P0785 — SHIFT/TIMING SOLENOID —

### 1. OUTLINE OF DIAGNOSIS

Judge NG when the 2-4 brake timing solenoid becomes battery short, ground short or open circuit.

### 2. COMPONENT DESCRIPTION

2-4 brake timing solenoid is installed to the transmission hydraulic control valve body. This solenoid is switched on or off by the signal from TCM. This allows controlling the 2-4 brake timing valve B and decreases the change gear shock.

### 3. ENABLE CONDITION

Secondary Parameters	Enable Conditions
None	

### 4. GENERAL DRIVING CYCLE

Always perform the diagnosis continuously.

### 5. DIAGNOSTIC METHOD

#### Judgment Value

Malfunction Criteria	Threshold Value
Vc at "ON" signal from ECM	Low level
Vc at "OFF" signal from ECM	High level

**Time Needed for Diagnosis:** 30 milliseconds

**Malfunction Indicator Light Illumination:** Illuminates when malfunction occurs in 2 continuous driving cycles.

### 6. DTC CLEAR CONDITION

- When the OK idling cycle was completed 40 times in a row
- When "Clear Memory" was performed

### 7. MALFUNCTION INDICATOR LIGHT CLEAR CONDITION

- When the OK driving cycle was completed 3 times in a row
- When "Clear Memory" was performed

### 8. FAIL SAFE

None

### 9. ECM OPERATION AT DTC SETTING

Memorize the freeze frame data. (For test mode \$02)

# DIAGNOSTIC TROUBLE CODE (DTC) DETECTING CRITERIA

## GENERAL DESCRIPTION

### CM:DTC P0851 — NEUTRAL SWITCH INPUT CIRCUIT LOW —

#### 1. OUTLINE OF DIAGNOSIS

- Detect the open/short circuit of neutral switch.
- AT: Judge NG when ECM neutral terminal input is different from reception data from TCM.
- MT: Judge NG when the neutral switch does not respond even though shift lever is changed (neutral switch is turned on or off by vehicle and engine speed).

#### 2. ENABLE CONDITION

Secondary Parameters	Enable Conditions
After engine starting	1 second or more
Starter switch	OFF
Battery voltage	≥ 8 V
Ignition switch	ON

#### 3. GENERAL DRIVING CYCLE

Perform the diagnosis continuously after starting the engine.

#### 4. DIAGNOSTIC METHOD

##### • Abnormality Judgment

AT: Judge NG when the continuing time of completing the malfunction criteria below reached to 5 seconds.

##### Judgment Value

Malfunction Criteria	Threshold Value
Switch signal	ON (Low)
“P” range / “N” range on AT	OFF
Any other switches on AT	ON

##### • Normality Judgment

AT: Judge OK and clear the NG when the malfunction criteria below are completed.

##### Judgment Value

Malfunction Criteria	Threshold Value
Switch signal	OFF (High)
“P” range / “N” range on AT	OFF
Any other switches on AT	ON

MT: Judge NG when the number of times until completing the malfunction criteria below continue 3 times in a row, judge OK when turning to OFF or ON.

##### Judgment Value

Malfunction Criteria	Threshold Value
Neutral switch on MT	Can not detect ON
Driving condition change a) Vehicle speed = 0 km/h (0 MPH) & engine speed 600 — 900 rpm b) Vehicle speed 64 — 106 km/h (40 — 66 MPH) & engine speed 1600 — 2550 rpm	While changing a) to b)

##### Time Needed for Diagnosis:

- Normal reception from AT is 5 times
- 3 monitoring on MT

**Malfunction Indicator Light Illumination:** Illuminates when malfunction occurs in 2 continuous driving cycles.

#### 5. DTC CLEAR CONDITION

- When the OK idling cycle is completed 40 times in a row
- When “Clear Memory” was performed

# DIAGNOSTIC TROUBLE CODE (DTC) DETECTING CRITERIA

GENERAL DESCRIPTION

---

## 6. MALFUNCTION INDICATOR LIGHT CLEAR CONDITION

- When the OK driving cycle was completed 3 times in a row
- When "Clear Memory" was performed

## 7. FAIL SAFE

None

## 8. ECM OPERATION AT DTC

Memorize the freeze frame data. (For test mode \$02)

# DIAGNOSTIC TROUBLE CODE (DTC) DETECTING CRITERIA

## GENERAL DESCRIPTION

### CN:DTC P0852 — NEUTRAL SWITCH INPUT CIRCUIT HIGH —

#### 1. OUTLINE OF DIAGNOSIS

- Detect the open/short circuit of neutral switch.
- AT: Judge NG when ECM neutral terminal input is different from reception data from TCM.
- MT: Judge NG when the neutral switch does not respond even though shift lever is changed (neutral switch is turned on or off by vehicle and engine speed).

#### 2. ENABLE CONDITION

Secondary Parameters	Enable Conditions
After engine starting	1 second or more
Starter switch	Turn off
Battery voltage	≥ 8 V
Ignition switch	ON

#### 3. GENERAL DRIVING CYCLE

Perform the diagnosis continuously after starting the engine.

#### 4. DIAGNOSTIC METHOD

##### • Abnormality Judgement

AT: Judge NG when the continuing time of completing the malfunction criteria below reached to 5 seconds.

##### Judgment Value

Malfunction Criteria	Threshold Value
Switch signal	OFF (High)
“P” range / “N” range on AT	ON
Any other switches on AT	OFF

##### • Normality Judgment

AT: Judge OK and clear the NG when the malfunction criteria below are completed.

##### Judgment Value

Malfunction Criteria	Threshold Value
Switch signal	ON (Low)
“P” range / “N” range on AT	ON
Any other switches on AT	OFF

MT: Judge NG when the number of times until completing the malfunction criteria below continue 3 times in a row, judge OK when turning to OFF or ON.

##### Judgment Value

Malfunction Criteria	Threshold Value
Neutral switch on MT	Can not detect SW OFF (High)
Driving condition change a) Vehicle speed = 0 km/h (0 MPH) & engine speed 600 — 900 rpm b) Vehicle speed 64 — 106 km/h (40 — 66 MPH) & engine speed 1600 — 2550 rpm	Change a) to b)

##### Time Needed for Diagnosis:

- 5 seconds on AT
- 3 monitoring on MT

**Malfunction Indicator Light Illumination:** Illuminates when malfunction occurs in 2 continuous driving cycles.

# DIAGNOSTIC TROUBLE CODE (DTC) DETECTING CRITERIA

GENERAL DESCRIPTION

---

## 5. DTC CLEAR CONDITION

- When the OK idling cycle is completed 40 times in a row
- When "Clear Memory" was performed

## 6. MALFUNCTION INDICATOR LIGHT CLEAR CONDITION

- When the OK driving cycle was completed 3 times in a row
- When "Clear Memory" was performed

## 7. FAIL SAFE

None

## 8. ECM OPERATION AT DTC

Memorize the freeze frame data. (For test mode \$02)

# DIAGNOSTIC TROUBLE CODE (DTC) DETECTING CRITERIA

## GENERAL DESCRIPTION

### CO:DTC P0864 — TCM COMMUNICATION CIRCUIT RANGE/PERFORMANCE —

#### 1. OUTLINE OF DIAGNOSIS

- Detect the communication malfunction of AT diagnosis.
- Judge NG when the communication format does not correspond.

#### 2. ENABLE CONDITION

Secondary Parameters	Enable Conditions
Battery voltage	≥ 8.0 V
Engine speed	≥ 500 rpm
Ignition switch	ON

#### 3. GENERAL DRIVING CYCLE

Perform the diagnosis continuously after starting the engine.

#### 4. DIAGNOSTIC METHOD

Judge NG when the continuous time communication format does not correspond continued for time needed for diagnosis. Judge OK and clear the NG when the communication format corresponds.

##### Judgment Value

Malfunction Criteria	Threshold Value
Incorrect pattern in wiring harness for communication	≥ 60 seconds

**Time Needed for Diagnosis:** 60 seconds

**Malfunction Indicator Light Illumination:** Illuminates when malfunction occurs in 2 continuous driving cycles.

#### 5. DTC CLEAR CONDITION

- When the OK idling cycle is completed 40 times in a row
- When “Clear Memory” was performed

#### 6. MALFUNCTION INDICATOR LIGHT CLEAR CONDITION

- When the OK driving cycle was completed 3 times in a row
- When “Clear Memory” was performed

#### 7. FAIL SAFE

None

#### 8. ECM OPERATION AT DTC

Memorize the freeze frame data. (For test mode \$02)



# DIAGNOSTIC TROUBLE CODE (DTC) DETECTING CRITERIA

GENERAL DESCRIPTION

## CP:DTC P0865 — TCM COMMUNICATION CIRCUIT LOW —

### 1. OUTLINE OF DIAGNOSIS

- Detect the open/short circuit of AT diagnosis line.
- Judge NG when the signal remains Low.

### 2. ENABLE CONDITION

Secondary Parameters	Enable Conditions
Battery voltage	≥ 8.0 V
Engine speed	≥ 500 rpm
Ignition switch	ON

### 3. GENERAL DRIVING CYCLE

Perform the diagnosis continuously after starting the engine.

### 4. DIAGNOSTIC METHOD

Judge NG when the malfunction criteria below are completed. Judge OK and clear the NG when the signal is turned over.

#### Judgment Value

Malfunction Criteria	Threshold Value
Continuing time of signal line is Low	≥ 3 seconds

**Time Needed for Diagnosis:** 3 seconds

**Malfunction Indicator Light Illumination:** Illuminates when malfunction occurs in 2 continuous driving cycles.

### 5. DTC CLEAR CONDITION

- When the OK idling cycle is completed 40 times in a row
- When “Clear Memory” was performed

### 6. MALFUNCTION INDICATOR LIGHT CLEAR CONDITION

- When the OK driving cycle was completed 3 times in a row
- When “Clear Memory” was performed

### 7. FAIL SAFE

None

### 8. ECM OPERATION AT DTC

Memorize the freeze frame data. (For test mode \$02)

# DIAGNOSTIC TROUBLE CODE (DTC) DETECTING CRITERIA

## GENERAL DESCRIPTION

---

### CQ:DTC P0866 — TCM COMMUNICATION CIRCUIT HIGH —

#### 1. OUTLINE OF DIAGNOSIS

- Detect the open/short circuit of AT diagnosis line.
- Judge NG when the signal remains High.

#### 2. ENABLE CONDITION

Secondary Parameters	Enable Conditions
Battery voltage	≥ 8.0 V
Engine speed	≥ 500 rpm
Ignition switch	ON

#### 3. GENERAL DRIVING CYCLE

Perform the diagnosis continuously after starting the engine.

#### 4. DIAGNOSTIC METHOD

Judge NG when the malfunction criteria below are completed. Judge OK and clear the NG when the signal is turned over.

##### Judgment Value

Malfunction Criteria	Threshold Value
Continuing time of signal line is High	≥ 3 seconds

**Time Needed for Diagnosis:** 3 seconds

**Malfunction Indicator Light Illumination:** Illuminates when malfunction occurs in 2 continuous driving cycles.

#### 5. DTC CLEAR CONDITION

- When the OK idling cycle is completed 40 times in a row
- When “Clear Memory” was performed

#### 6. MALFUNCTION INDICATOR LIGHT CLEAR CONDITION

- When the OK driving cycle was completed 3 times in a row
- When “Clear Memory” was performed

#### 7. FAIL SAFE

None

#### 8. ECM OPERATION AT DTC

Memorize the freeze frame data. (For test mode \$02)

# DIAGNOSTIC TROUBLE CODE (DTC) DETECTING CRITERIA

GENERAL DESCRIPTION

## CR:DTC P1110 — ATMOSPHERIC PRESSURE SENSOR CIRCUIT MALFUNCTION (LOW INPUT) —

### 1. OUTLINE OF DIAGNOSIS

- Detect the open/short circuit of atmospheric pressure sensor.
- Judge NG when out of the standard value.

### 2. COMPONENT DESCRIPTION

Atmospheric pressure sensor is built in ECM.

### 3. ENABLE CONDITION

Secondary Parameters	Enable Conditions
Engine speed	≥ 500 rpm
Battery voltage	≥ 10 V
Timer after starting the engine	≥ 2 seconds
Ignition switch	ON

### 4. GENERAL DRIVING CYCLE

Perform the diagnosis continuously in 2 seconds after starting the engine.

### 5. DIAGNOSTIC METHOD

Judge NG when the continuous time until completing the malfunction criteria below becomes more than the time (2.5 seconds) needed for diagnosis. Judge fail safe NG when the continuous time until completing the malfunction criteria below becomes more than the time (0.1 seconds) needed for diagnosis. Judge OK and clear the NG when the malfunction criteria below are not completed.

#### Judgment Value

Malfunction Criteria	Threshold Value
Output voltage	≤ 0.1 V

**Time Needed for Diagnosis:** 2.5 seconds

**Malfunction Indicator Light Illumination:** Illuminates as soon as malfunction occurs.

### 6. DTC CLEAR CONDITION

- When the OK idling cycle is completed 40 times in a row
- When “Clear Memory” was performed

### 7. MALFUNCTION INDICATOR LIGHT CLEAR CONDITION

- When the OK driving cycle is completed 3 times in a row
- When “Clear Memory” was performed

### 8. FAIL SAFE

Make the atmospheric pressure 101 kPa (760 mmHg, 30 inHg).

### 9. ECM OPERATION AT DTC SETTING

Memorize the freeze frame data. (For test mode \$02)

# DIAGNOSTIC TROUBLE CODE (DTC) DETECTING CRITERIA

## GENERAL DESCRIPTION

---

### CS:DTC P1111 — ATMOSPHERIC PRESSURE SENSOR CIRCUIT MALFUNCTION (HIGH INPUT) —

#### 1. OUTLINE OF DIAGNOSIS

- Detect the open/short circuit of atmospheric pressure sensor.
- Judge NG when out of the standard value.

#### 2. COMPONENT DESCRIPTION

Atmospheric pressure sensor is built in ECM.

#### 3. ENABLE CONDITION

Secondary Parameters	Enable Conditions
Ignition switch	ON

#### 4. GENERAL DRIVING CYCLE

Always perform the diagnosis continuously.

#### 5. DIAGNOSTIC METHOD

Judge NG when the continuous time until completing the malfunction criteria below becomes more than the time (2.5 seconds) needed for diagnosis. Judge fail safe NG when the cumulative time until completing the malfunction criteria below becomes more than the time (0.1 seconds) needed for diagnosis. Judge OK and clear the NG when the malfunction criteria below are not completed.

##### Judgment Value

Malfunction Criteria	Threshold Value
Output voltage	$\geq 4.8$ V

**Time Needed for Diagnosis:** 2.5 seconds

**Malfunction Indicator Light Illumination:** Illuminates as soon as malfunction occurs.

#### 6. DTC CLEAR CONDITION

- When the OK idling cycle is completed 40 times in a row
- When "Clear Memory" was performed

#### 7. MALFUNCTION INDICATOR LIGHT CLEAR CONDITION

- When the OK driving cycle is completed 3 times in a row
- When "Clear Memory" was performed

#### 8. FAIL SAFE

Make the atmospheric pressure 101 kPa (760 mmHg, 30 inHg).

#### 9. ECM OPERATION AT DTC SETTING

Memorize the freeze frame data. (For test mode \$02)

# DIAGNOSTIC TROUBLE CODE (DTC) DETECTING CRITERIA

GENERAL DESCRIPTION

## CT:DTC P1134 — A/F SENSOR MICRO-COMPUTER PROBLEM —

### 1. OUTLINE OF DIAGNOSIS

- Detect the malfunction of IC communication.
- Judge NG when the communication to front oxygen (A/F) sensor control IC is unable.

### 2. COMPONENT DESCRIPTION

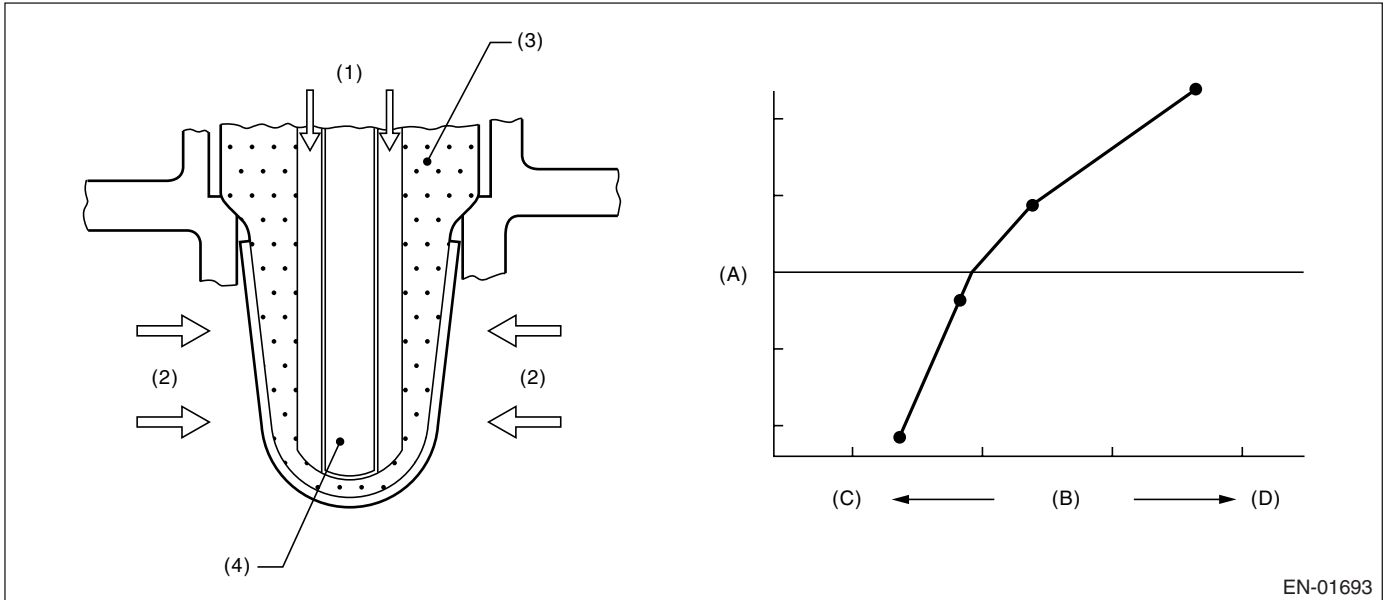

- (1) Atmospheric air
- (2) Exhaust gas
- (3) ZrO<sub>2</sub>
- (4) Ceramic heater

- (A) Electromotive force
- (B) Air fuel ratio
- (C) Lean
- (D) Rich

### 3. ENABLE CONDITION

Secondary Parameters	Enable Conditions
Battery voltage	≥ 10.9 V
After engine starting	≥ 140 seconds

### 4. GENERAL DRIVING CYCLE

Perform the diagnosis continuously in 140 seconds after starting the engine.

# DIAGNOSTIC TROUBLE CODE (DTC) DETECTING CRITERIA

## GENERAL DESCRIPTION

---

### 5. DIAGNOSTIC METHOD

#### • Abnormality Judgment

Judge NG when the malfunction criteria below are completed.

#### Judgment Value

Malfunction Criteria	Threshold Value
Communication error to main CPU	≥ 250 times

**Time Needed for Diagnosis:** 12.5 seconds

**Malfunction Indicator Light Illumination:** Illuminates as soon as malfunction occurs.

#### • Normality Judgment

Judge OK and clear the NG when the malfunction criteria below are completed.

#### Judgment Value

Malfunction Criteria	Threshold Value
Error	None

### 6. DTC CLEAR CONDITION

- When the OK idling cycle is completed 40 times in a row
- When "Clear Memory" was performed

### 7. MALFUNCTION INDICATOR LIGHT CLEAR CONDITION

- When the OK driving cycle is completed 3 times in a row
- When "Clear Memory" was performed

### 8. FAIL SAFE

None

### 9. ECM OPERATION AT DTC SETTING

Memorize the freeze frame data. (For test mode \$02)

# DIAGNOSTIC TROUBLE CODE (DTC) DETECTING CRITERIA

GENERAL DESCRIPTION

## CU:DTC P1137 — O<sub>2</sub> SENSOR CIRCUIT LOW VOLTAGE (BANK 1 SENSOR 2) — Middle Electric Potential

### 1. OUTLINE OF DIAGNOSIS

- Detect the output property malfunction of from oxygen (A/F) sensor.
- Judge NG when output voltage does not move to lean side or rich side.

### 2. COMPONENT DESCRIPTION

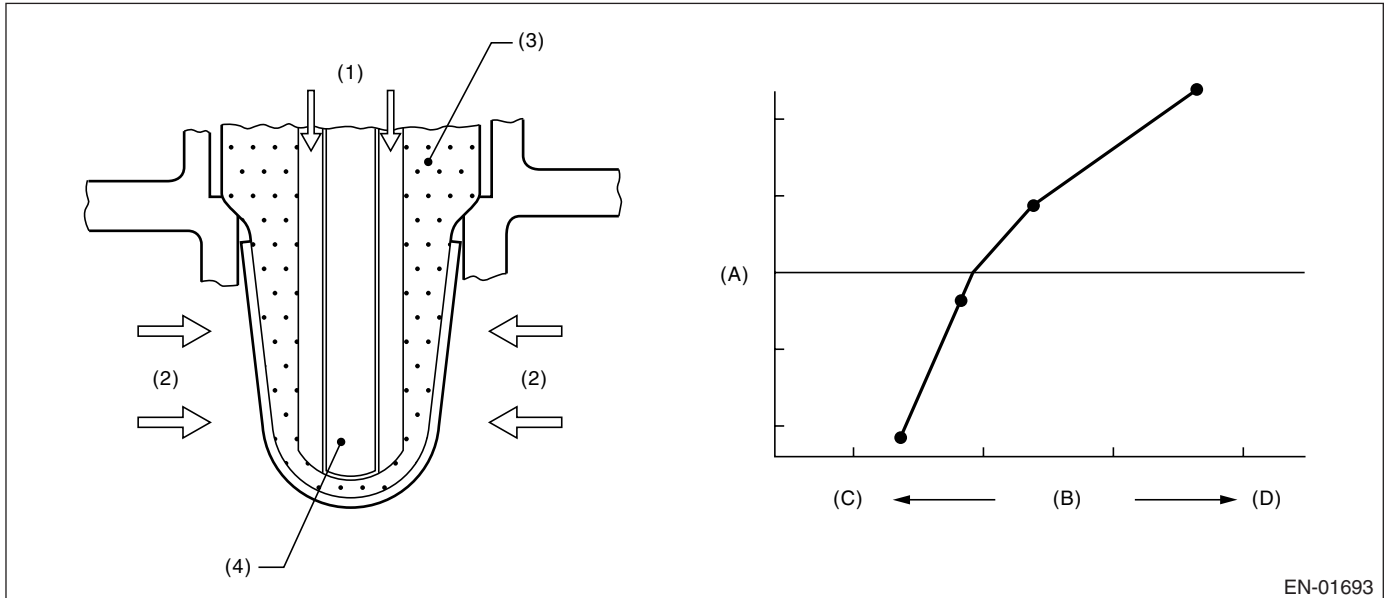

- (1) Atmosphere
- (2) Exhaust gas
- (3) ZrO<sub>2</sub>
- (4) Ceramic rotor

- (A) Electromotive force
- (B) Air fuel ratio
- (C) Lean
- (D) Rich

EN-01693

### 3. ENABLE CONDITION

Secondary Parameter	Enable Conditions
A/F sensor response diagnosis	Under diagnosis

### 4. GENERAL DRIVING CYCLE

Perform the diagnosis just once in 225 seconds or more after starting the engine constantly at 76 km/h (47 MPH) or more of vehicle speed (Same as A/F sensor response diagnosis).

# DIAGNOSTIC TROUBLE CODE (DTC) DETECTING CRITERIA

## GENERAL DESCRIPTION

---

### 5. DIAGNOSTIC METHOD

#### • Abnormality Judgment

Judge NG when one of the malfunction criteria below is completed.

#### Judgment Value

Malfunction Criteria	Threshold Value
Continuous time of output voltage > 2.065 V ( $\lambda = 0.98$ )	3.4 seconds or more
Continuous time of output voltage < 2.180 V ( $\lambda = 1.0$ )	3.4 seconds or more

**Time needed for diagnosis:** 3.4 seconds

**Malfunction Indicator Light Illumination:** Illuminates as soon as malfunction occurs.

#### • Normality Judgment

Judge OK when all the malfunction criteria below are completed.

#### Judgment Value

Malfunction Criteria	Threshold Value
Cumulative time of output voltage $\leq$ 2.065 V	0.2 seconds or more
Cumulative time of output voltage $\geq$ 2.180 V	0.2 seconds or more

### 6. DTC CLEAR CONDITION

- When the OK idling cycle was completed 40 times in a row
- When "Clear Memory" was performed

### 7. MALFUNCTION INDICATOR LIGHT CLEAR CONDITION

- When the OK driving cycle was completed 3 times in a row
- When "Clear Memory" was performed

### 8. FAIL SAFE

None

### 9. ECM OPERATION AT DTC SETTING

- Memorize the freeze frame data. (For test mode \$02)
- Memorize the diagnostic value and trouble standard value. (For test mode \$06)



# DIAGNOSTIC TROUBLE CODE (DTC) DETECTING CRITERIA

GENERAL DESCRIPTION

## CV:DTC P1400 — FUEL TANK PRESSURE CONTROL SOLENOID VALVE CIRCUIT LOW —

### 1. OUTLINE OF DIAGNOSIS

- Detect the open/short circuit of pressure control solenoid valve.
- Judge NG when ECM output level is different from actual terminal level.

### 2. COMPONENT DESCRIPTION

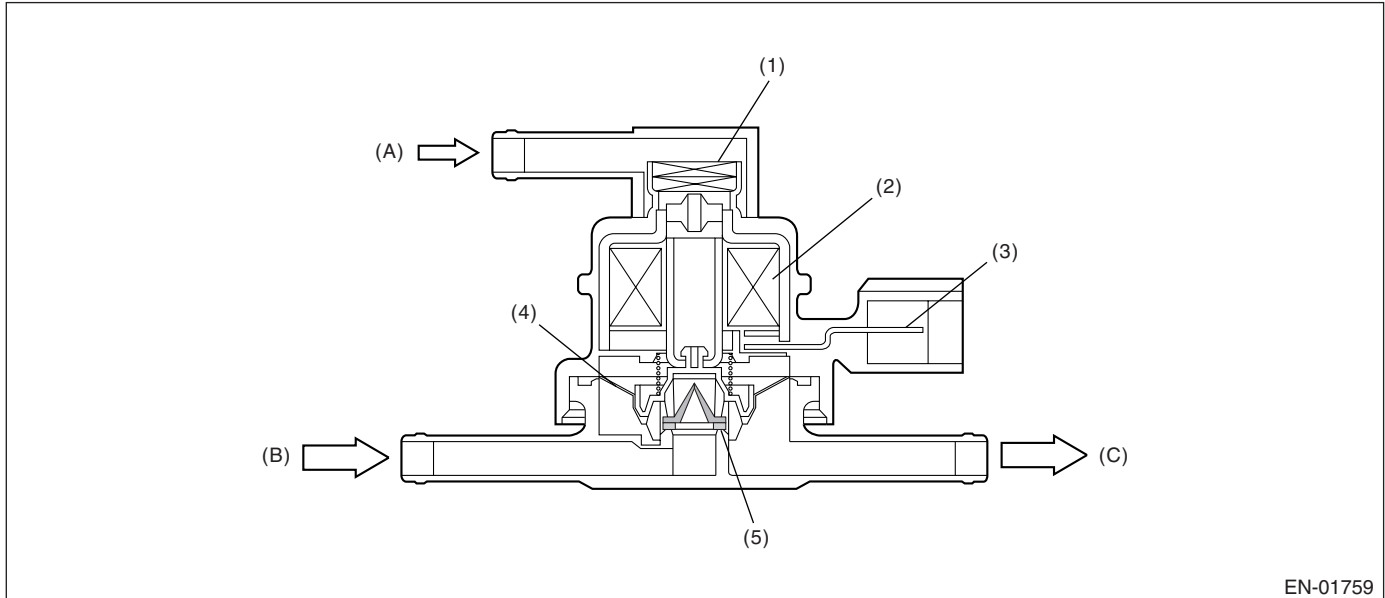

- (1) Filter
- (2) Coil
- (3) Connector terminal
- (4) Diaphragm
- (5) Valve

- (A) Atmospheric pressure
- (B) Shut-off valve
- (C) To fuel tank

### 3. ENABLE CONDITION

Secondary Parameters	Enable Conditions
Engine speed	$\geq 500$ rpm
Battery voltage	$\geq 8$ V
After engine starting	1 second or more
Ignition switch	ON

### 4. GENERAL DRIVING CYCLE

Perform the diagnosis continuously after starting the engine.

# DIAGNOSTIC TROUBLE CODE (DTC) DETECTING CRITERIA

## GENERAL DESCRIPTION

---

### 5. DIAGNOSTIC METHOD

#### • Abnormality Judgment

Judge NG when the continuous time until completing the malfunction criteria below becomes more than time needed for diagnosis (2.5 seconds).

#### Judgment Value

Malfunction Criteria	Threshold Value
Terminal voltage when ECM outputs OFF signal	Low

**Time Needed for Diagnosis:** 2.5 seconds

**Malfunction Indicator Light Illumination:** Illuminates when malfunction occurs in 2 continuous driving cycles.

#### • Normality Judgment

Judge OK and clear the NG when the malfunction criteria below are completed.

#### Judgment Value

Malfunction Criteria	Threshold Value
Terminal voltage when ECM outputs OFF signal	High

### 6. DTC CLEAR CONDITION

- When the OK idling cycle is completed 40 times in a row
- When "Clear Memory" was performed

### 7. MALFUNCTION INDICATOR LIGHT CLEAR CONDITION

- When the OK driving cycle was completed 3 times in a row
- When "Clear Memory" was performed

### 8. FAIL SAFE

None

### 9. ECM OPERATION AT DTC

Memorize the freeze frame data. (For test mode \$02)

## CW:DTC P1420 — FUEL TANK PRESSURE CONTROL SOL. VALVE CIRCUIT HIGH —

### 1. OUTLINE OF DIAGNOSIS

- Detect the open/short circuit of pressure control solenoid valve.
- Judge NG when ECM output level is different from actual terminal level.

### 2. COMPONENT DESCRIPTION

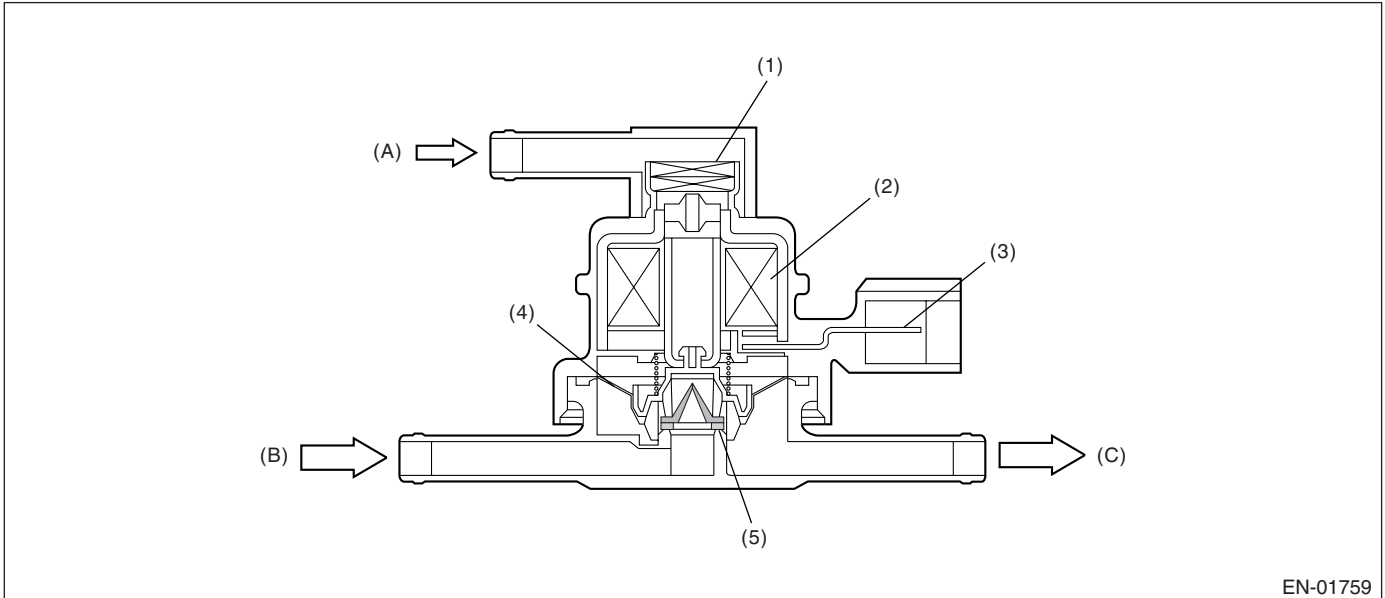

- |                        |                          |
|------------------------|--------------------------|
| (1) Filter             | (A) Atmospheric pressure |
| (2) Coil               | (B) Shut-off valve       |
| (3) Connector terminal | (C) To fuel tank         |
| (4) Diaphragm          |                          |
| (5) Valve              |                          |

### 3. ENABLE CONDITION

Secondary Parameters	Enable Conditions
Engine speed	≥ 500 rpm
Battery voltage	≥ 8 V
After engine starting	1 second or more
Ignition switch	ON

### 4. GENERAL DRIVING CYCLE

Perform the diagnosis continuously after starting the engine.

# DIAGNOSTIC TROUBLE CODE (DTC) DETECTING CRITERIA

## GENERAL DESCRIPTION

---

### 5. DIAGNOSTIC METHOD

#### • Abnormality Judgment

Judge NG when the continuous time until completing the malfunction criteria below becomes more than time needed for diagnosis (2.5 seconds).

#### Judgment Value

Malfunction Criteria	Threshold Value
Terminal voltage when ECM outputs ON signal	High

**Time Needed for Diagnosis:** 2.5 seconds

**Malfunction Indicator Light Illumination:** Illuminates when malfunction occurs in 2 continuous driving cycles.

#### • Normality Judgment

Judge OK and clear the NG when the malfunction criteria below are completed.

#### Judgment Value

Malfunction Criteria	Threshold Value
Terminal voltage when ECM outputs ON signal	Low

### 6. DTC CLEAR CONDITION

- When the OK idling cycle is completed 40 times in a row
- When "Clear Memory" was performed

### 7. MALFUNCTION INDICATOR LIGHT CLEAR CONDITION

- When the OK driving cycle was completed 3 times in a row
- When "Clear Memory" was performed

### 8. FAIL SAFE

None

### 9. ECM OPERATION AT DTC

Memorize the freeze frame data. (For test mode \$02)

# DIAGNOSTIC TROUBLE CODE (DTC) DETECTING CRITERIA

GENERAL DESCRIPTION

---

## **CX:DTC P1443 — VENT CONTROL SOLENOID VALVE FUNCTION PROBLEM —**

### **1. OUTLINE OF DIAGNOSIS**

For detecting conditions, refer to DTC P0442 EVAPORATIVE EMISSION CONTROL SYSTEM LEAK DETECTED (SMALL LEAK). <Ref. to GD(H4SO)-114, DTC P0442 — EVAPORATIVE EMISSION CONTROL SYSTEM LEAK DETECTED (SMALL LEAK) —, Diagnostic Trouble Code (DTC) Detecting Criteria.>

# DIAGNOSTIC TROUBLE CODE (DTC) DETECTING CRITERIA

## GENERAL DESCRIPTION

### CY:DTC P1446 — FUEL TANK SENSOR CONTROL VALVE CIRCUIT LOW —

#### 1. OUTLINE OF DIAGNOSIS

- Detect the open/short circuit of fuel tank sensor control valve.
- Judge NG when the ECM output level is different from actual terminal level.

#### 2. COMPONENT DESCRIPTION

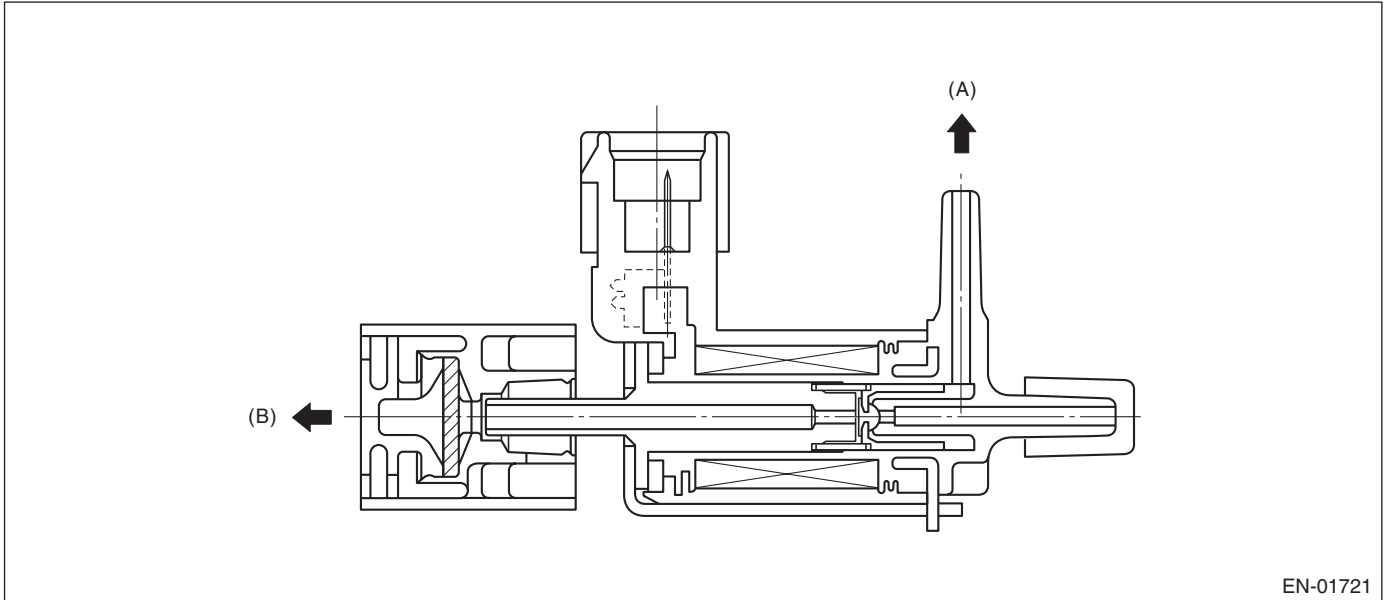

(A) Fuel tank pressure sensor

(B) External air

#### 3. ENABLE CONDITION

Secondary Parameters	Enable Conditions
Engine speed	$\geq 500$ rpm
Battery voltage	$\geq 8$ V
After engine starting	1 second or more
Ignition switch	ON

#### 4. GENERAL DRIVING CYCLE

Perform the diagnosis continuously after starting the engine.

#### 5. DIAGNOSTIC METHOD

Judge NG when the continuous time until completing the malfunction criteria below becomes more than the time (2.5 seconds) needed for diagnosis. Judge OK and clear the NG when the malfunction criteria are not completed.

##### Judgment Value

Malfunction Criteria	Threshold Value
Terminal voltage level when ECM sent OFF signals	Low level

**Time Needed for Diagnosis:** 2.5 seconds

**Malfunction Indicator Light Illumination:** Illuminates when malfunction occurs in 2 continuous driving cycles.

# DIAGNOSTIC TROUBLE CODE (DTC) DETECTING CRITERIA

GENERAL DESCRIPTION

---

## 6. DTC CLEAR CONDITION

- When the OK idling cycle is completed 40 times in a row
- When "Clear Memory" was performed

## 7. MALFUNCTION INDICATOR LIGHT CLEAR CONDITION

- When the OK driving cycle is completed 3 times in a row
- When "Clear Memory" was performed

## 8. FAIL SAFE

None

## 9. ECM OPERATION AT DTC SETTING

Memorize the freeze frame data. (For test mode \$02)

# DIAGNOSTIC TROUBLE CODE (DTC) DETECTING CRITERIA

## GENERAL DESCRIPTION

### CZ:DTC P1447 — FUEL TANK SENSOR CONTROL VALVE CIRCUIT HIGH —

#### 1. OUTLINE OF DIAGNOSIS

- Detect the open/short circuit of fuel tank sensor control valve.
- Judge NG when the ECM output level is different from actual terminal level.

#### 2. COMPONENT DESCRIPTION

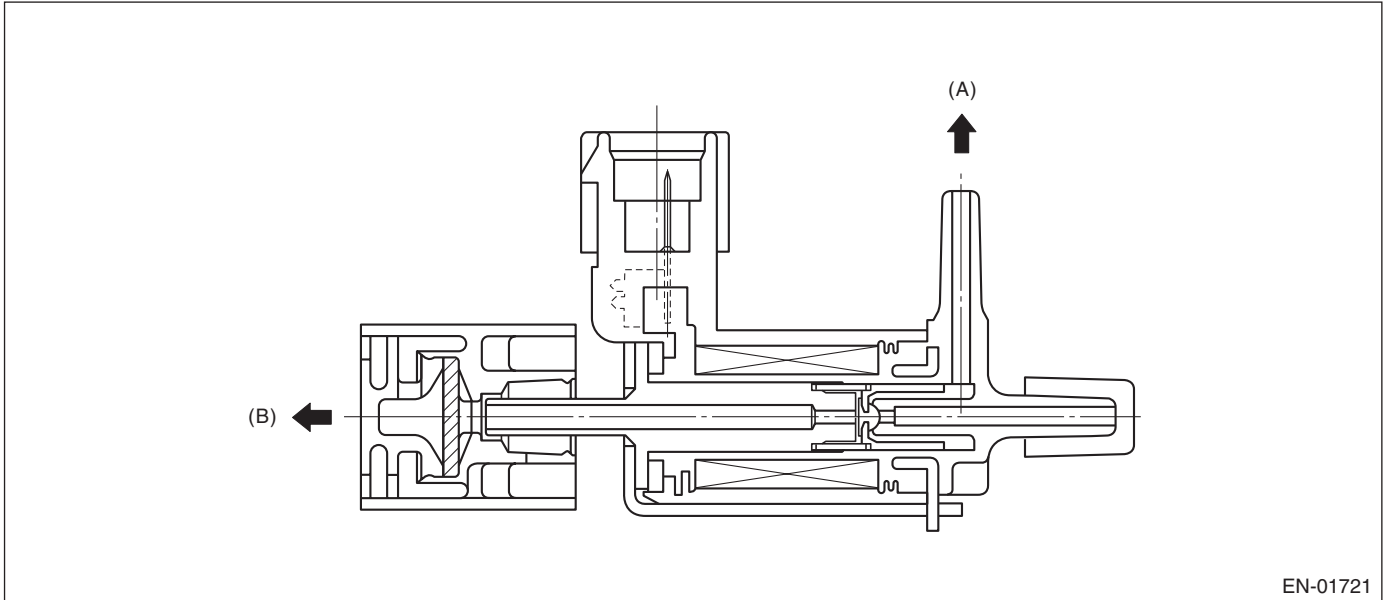

(A) Fuel tank pressure sensor

(B) External air

#### 3. ENABLE CONDITION

Secondary Parameters	Enable Conditions
Engine speed	$\geq 500$ rpm
Battery voltage	$\geq 8$ V
After engine starting	1 second or more
Ignition switch	ON

#### 4. GENERAL DRIVING CYCLE

Perform the diagnosis continuously after starting the engine.

#### 5. DIAGNOSTIC METHOD

Judge NG when the continuous time until completing the malfunction criteria below becomes more than the time (2.5 seconds) needed for diagnosis. Judge OK and clear the NG when the malfunction criteria are not completed.

##### Judgment Value

Malfunction Criteria	Threshold Value
Terminal voltage level when ECM sent ON signals	High level

**Time Needed for Diagnosis:** 2.5 seconds

**Malfunction Indicator Light Illumination:** Illuminates when malfunction occurs in 2 continuous driving cycles.



# DIAGNOSTIC TROUBLE CODE (DTC) DETECTING CRITERIA

GENERAL DESCRIPTION

---

## 6. DTC CLEAR CONDITION

- When the OK idling cycle is completed 40 times in a row
- When "Clear Memory" was performed

## 7. MALFUNCTION INDICATOR LIGHT CLEAR CONDITION

- When the OK driving cycle is completed 3 times in a row
- When "Clear Memory" was performed

## 8. FAIL SAFE

None

## 9. ECM OPERATION AT DTC SETTING

Memorize the freeze frame data. (For test mode \$02)

# DIAGNOSTIC TROUBLE CODE (DTC) DETECTING CRITERIA

## GENERAL DESCRIPTION

### DA:DTC P1448 — FUEL TANK SENSOR CONTROL VALVE RANGE/PERFORMANCE —

#### 1. OUTLINE OF DIAGNOSIS

Detect the tank pressure switching solenoid function abnormality.

The tank pressure sensor is a relative pressure sensor, which normally compares the pressure with the atmospheric pressure. The tank pressure switching solenoid is a solenoid, which shifts the compare space from opening to closed during the EVAP diagnosis. Detect the malfunction that the compare space remains closed. (Not judge NG after enable condition completed but assume NG before enable condition completed.)

#### • Normality Judgment

Judge OK when the fuel tank pressure does not change (or changes by less than 0.67 kPa (5 mmHg, 0.2 inHg) at atmospheric pressure changing by 0.67 kPa (5 mmHg, 0.2 inHg) or more per 80 seconds.

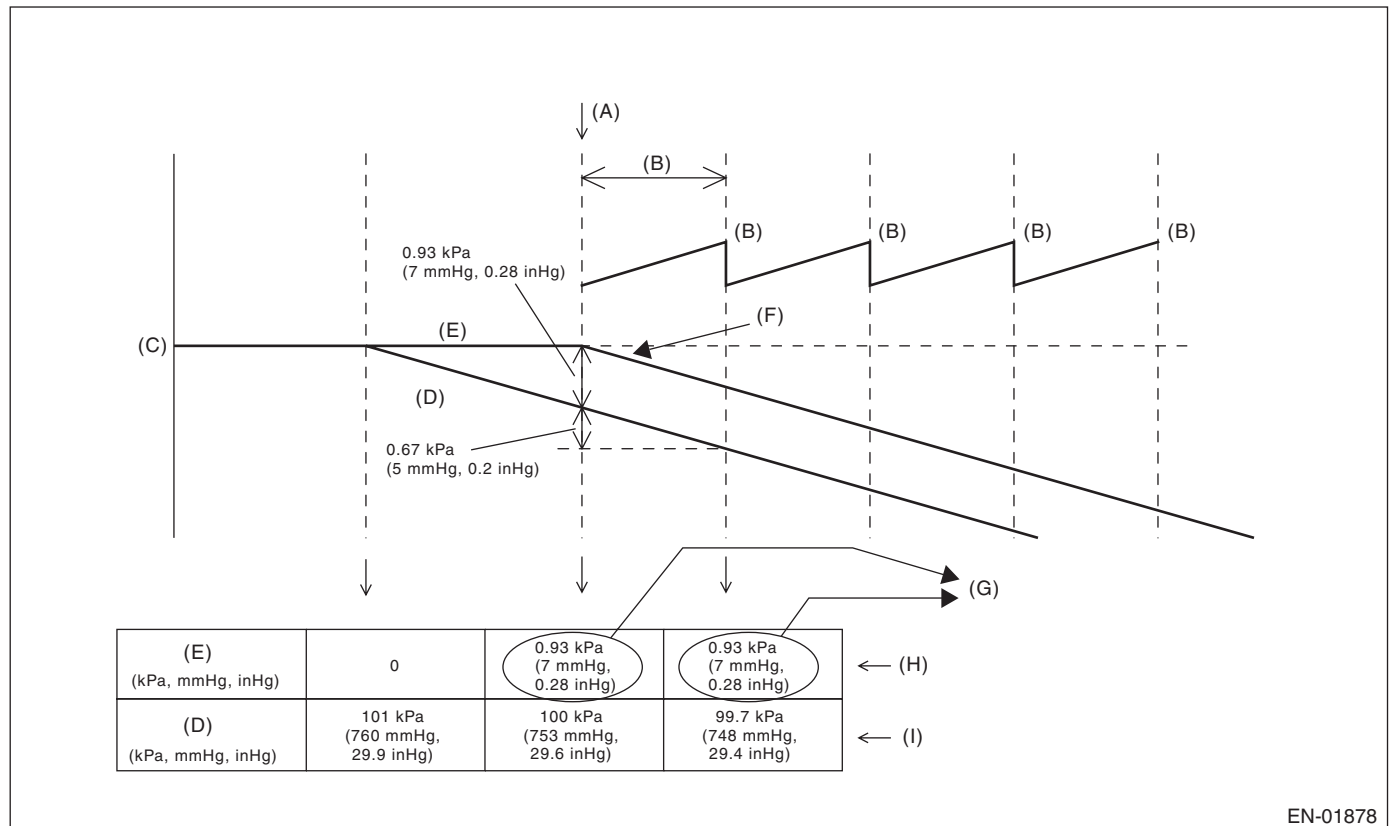

- (A) Enable conditions are completed.
- (B) 80 s
- (C) Pressure
- (D) Atmospheric pressure
- (E) Tank pressure
- (F) PCV function reduces the tank pressure.

- (G) Judge OK when the tank pressure does not change.
- (H) The tank pressure is relative pressure against atmospheric pressure.
- (I) Atmospheric pressure is absolute pressure.

# DIAGNOSTIC TROUBLE CODE (DTC) DETECTING CRITERIA

GENERAL DESCRIPTION

## • Abnormality Judgment

Judge NG temporarily when the fuel tank pressure changes by 0.67 kPa (5 mmHg, 0.2 inHg) or more at atmospheric pressure changing by 0.67 kPa (5 mmHg, 0.2 inHg) or more per 80 seconds, and then judge NG when the previous condition is completed 5 times in a row.

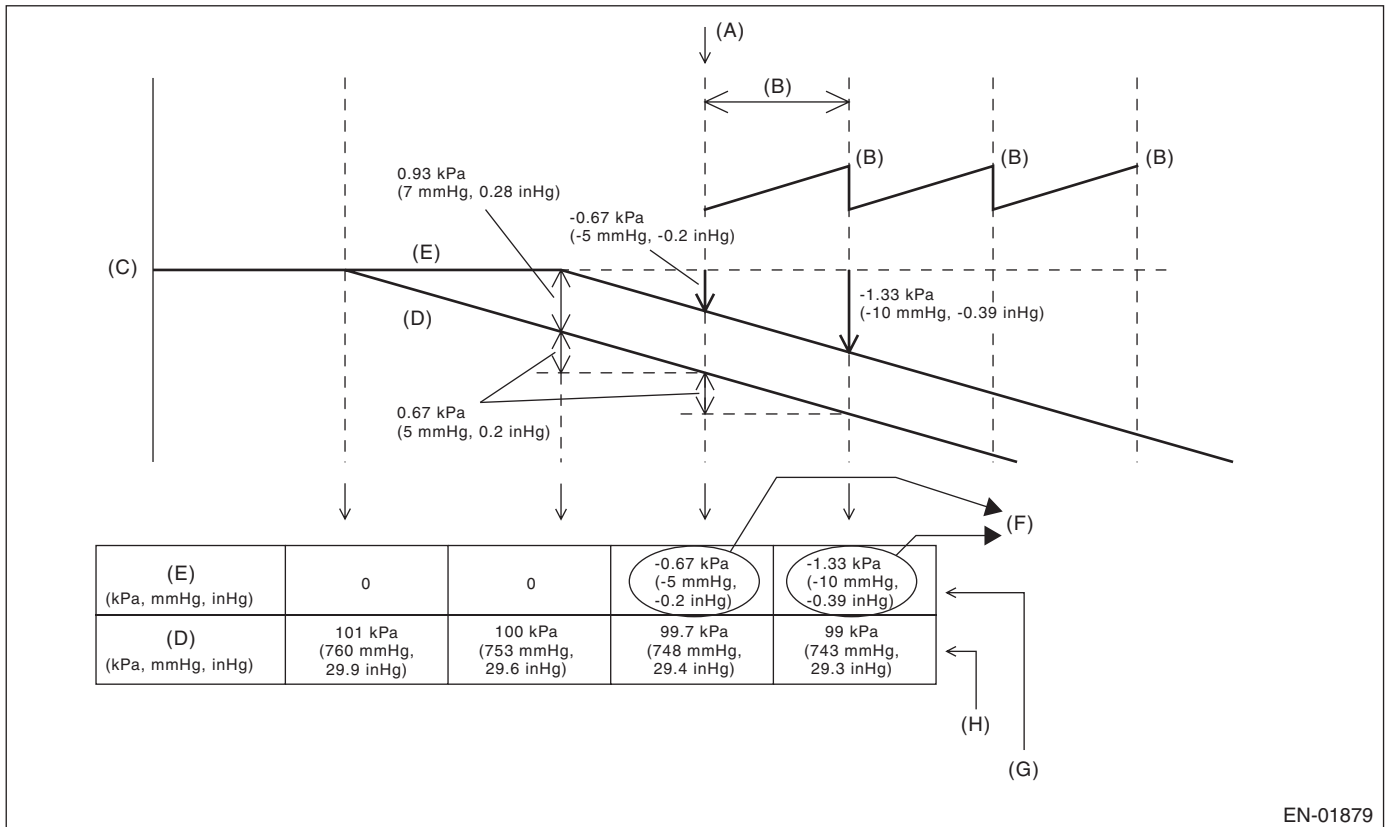

- (A) Enable conditions are completed.
- (B) 80 s
- (C) Pressure
- (D) Atmospheric pressure
- (E) Tank pressure
- (F) Judge NG temporarily the tank pressure changes once, and then judge NG the tank pressure changes five times in a row.

- (G) The tank pressure sensor outputs the value that is relative pressure against the closed compare space (760 mmHg).
- (H) Atmospheric pressure is absolute pressure.

# DIAGNOSTIC TROUBLE CODE (DTC) DETECTING CRITERIA

## GENERAL DESCRIPTION

### 2. COMPONENT DESCRIPTION

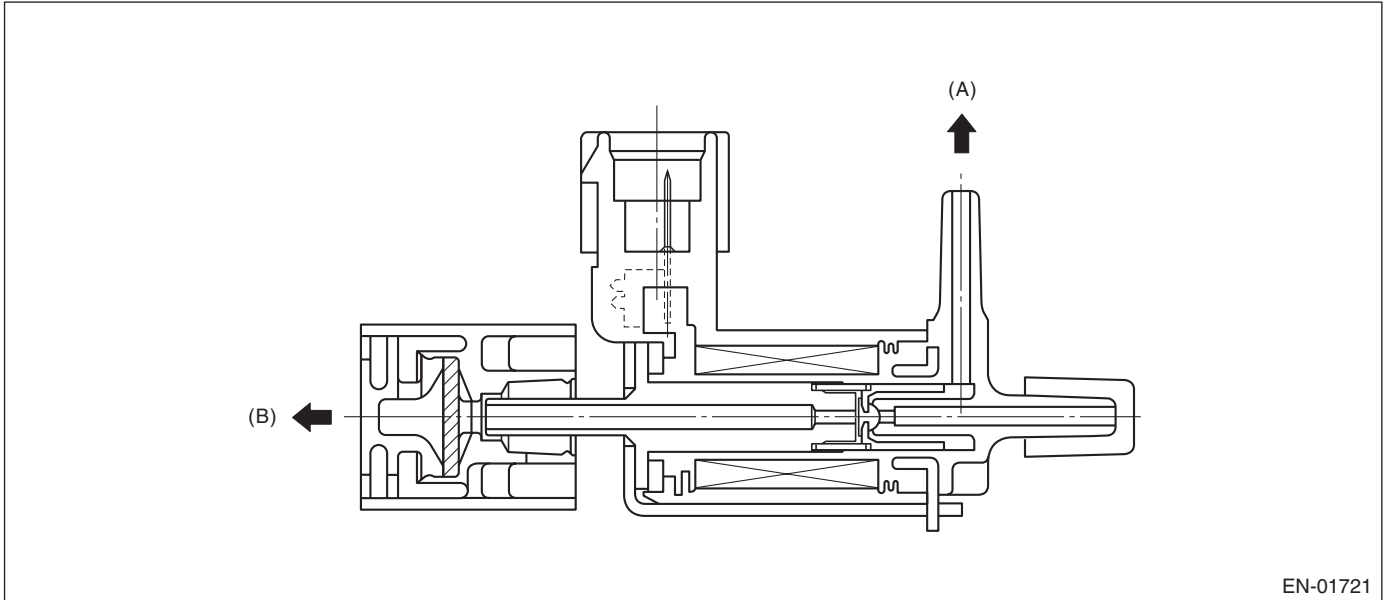

- (A) Fuel tank pressure sensor
- (B) External air

### 3. ENABLE CONDITION

Secondary Parameters	Enable Conditions
After engine starting	≥ 80 seconds
Fuel level	9 to 51 ℓ (2.4 — 13.5 US gal, 2.0 — 11.2 Imp gal)
Fuel tank pressure	< 0 or > 1200 Pa (< 0 or > 9.0 mmHg, < 0 or > 0.4 inHg)

### 4. GENERAL DRIVING CYCLE

Perform the diagnosis continuously in 80 seconds after starting the engine. (Do not diagnose during evaporative emission control system diagnosis.)

### 5. DIAGNOSTIC METHOD

#### • Abnormality Judgment

Count the counter up when the malfunction criteria below are completed by checking the change such as tank pressure, atmospheric pressure and fuel level during every 80 seconds. Judge NG when the count comes to the specified number (3 times).

#### Judgment Value

Malfunction Criteria	Threshold Value
Change of tank pressure during 80 seconds	≥ 600 Pa (4.5 mmHg, 0.2 inHg)
Change of atmospheric pressure during 80 seconds	≥ 600 Pa (4.5 mmHg, 0.2 inHg)
Change of fuel level during 80 seconds	< 8 ℓ (2.1 US gal, 1.8 Imp gal)

**Time Needed for Diagnosis:** 80 seconds × 3 times

**Malfunction Indicator Light Illumination:** Illuminates when malfunction occurs in 2 continuous driving cycles.

# DIAGNOSTIC TROUBLE CODE (DTC) DETECTING CRITERIA

GENERAL DESCRIPTION

## • Normality Judgment

Judge OK and clear the NG when all the malfunction criteria below are completed.

### Judgment Value

Malfunction Criteria	Threshold Value
Change of tank pressure during 80 seconds	$\geq 600$ Pa (4.5 mmHg, 0.2 inHg)
Change of atmospheric pressure during 80 seconds	$< 600$ Pa (4.5 mmHg, 0.2 inHg)

## 6. DTC CLEAR CONDITION

- When the OK idling cycle is completed 40 times in a row
- When "Clear Memory" was performed

## 7. MALFUNCTION INDICATOR LIGHT CLEAR CONDITION

- When the OK driving cycle is completed 3 times in a row
- When "Clear Memory" was performed

## 8. FAIL SAFE

None

## 9. ECM OPERATION AT DTC SETTING

Memorize the freeze frame data. (For test mode \$02)

# DIAGNOSTIC TROUBLE CODE (DTC) DETECTING CRITERIA

## GENERAL DESCRIPTION

### DB:DTC P1492 — EGR SOLENOID VALVE SIGNAL #1 CIRCUIT MALFUNCTION (LOW INPUT) —

#### 1. OUTLINE OF DIAGNOSIS

- Detect the open/short circuit of EGR.
- Judge NG when ECM output level is different from actual terminal level.

#### 2. COMPONENT DESCRIPTION

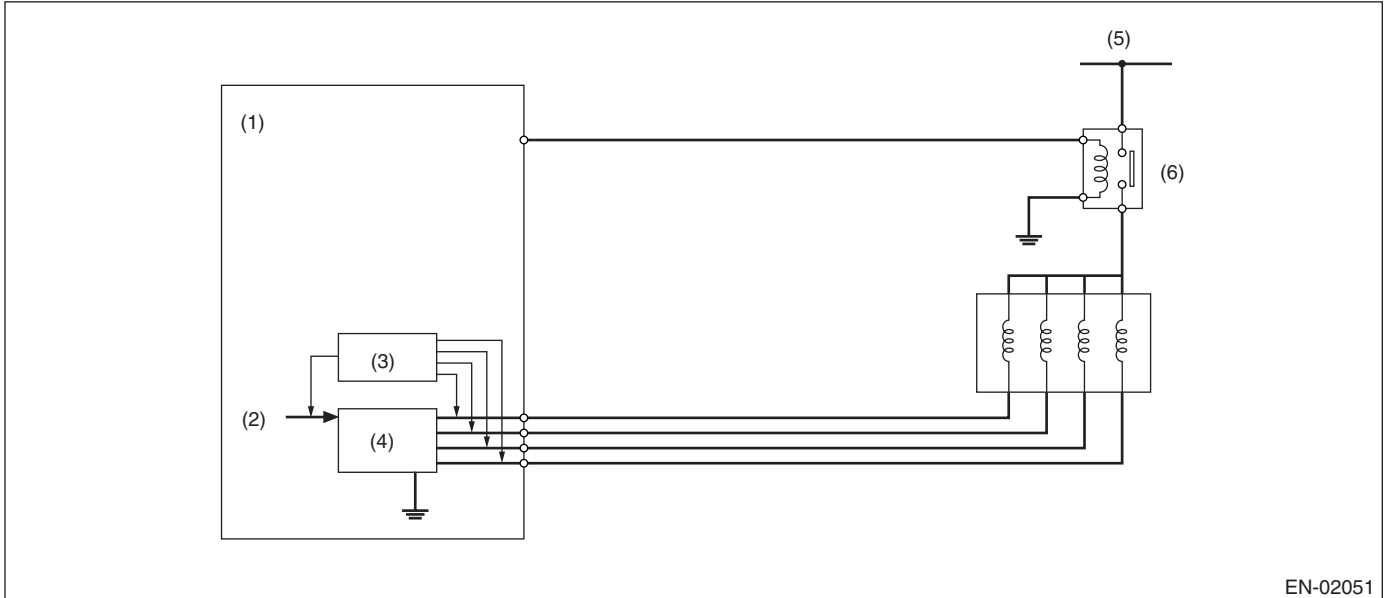

- (1) Engine Control Module (ECM)
- (2) CPU
- (3) Detecting circuit

- (4) Switching circuit
- (5) Battery voltage
- (6) Main relay

#### 3. ENABLE CONDITION

Secondary Parameters	Enable Conditions
Ignition switch	OFF
Battery voltage	> 10.9 V

#### 4. GENERAL DRIVING CYCLE

Always perform the diagnosis continuously.

#### 5. DIAGNOSTIC METHOD

##### • Abnormality Judgment

Judge NG when the cumulative time until completing the malfunction criteria below becomes more than time needed for diagnosis.

##### • Normality Judgement

Judge OK and clear the NG when the malfunction criteria below are not completed.

##### Judgment Value

Malfunction Criteria	Threshold Value	DTC	
Terminal voltage level when ECM outputs OFF signal	Low level	P1492	P1496
		P1494	P1498
Terminal voltage level when ECM outputs ON signal	High level	P1493	P1497
		P1495	P1499

# DIAGNOSTIC TROUBLE CODE (DTC) DETECTING CRITERIA

GENERAL DESCRIPTION

---

**Time Needed for Diagnosis:** 2.5 seconds

**Malfunction Indicator Light Illumination:** Illuminates as soon as the malfunction occurs.

## 6. DTC CLEAR CONDITION

- When the OK idling cycle is completed 40 times in a row
- When "Clear Memory" was performed

## 7. MALFUNCTION INDICATOR LIGHT CLEAR CONDITION

- When the OK driving cycle was completed 3 times in a row
- When "Clear Memory" was performed

## 8. FAIL SAFE

None

## 9. ECM OPERATION AT DTC

Memorize the freeze frame data. (For test mode \$02)

# DIAGNOSTIC TROUBLE CODE (DTC) DETECTING CRITERIA

## GENERAL DESCRIPTION

### DC:DTC P1493 — EGR SOLENOID VALVE SIGNAL #1 CIRCUIT MALFUNCTION (HIGH INPUT) —

#### 1. OUTLINE OF DIAGNOSIS

- Detect the open/short circuit of EGR.
- Judge NG when ECM output level is different from actual terminal level.

#### 2. COMPONENT DESCRIPTION

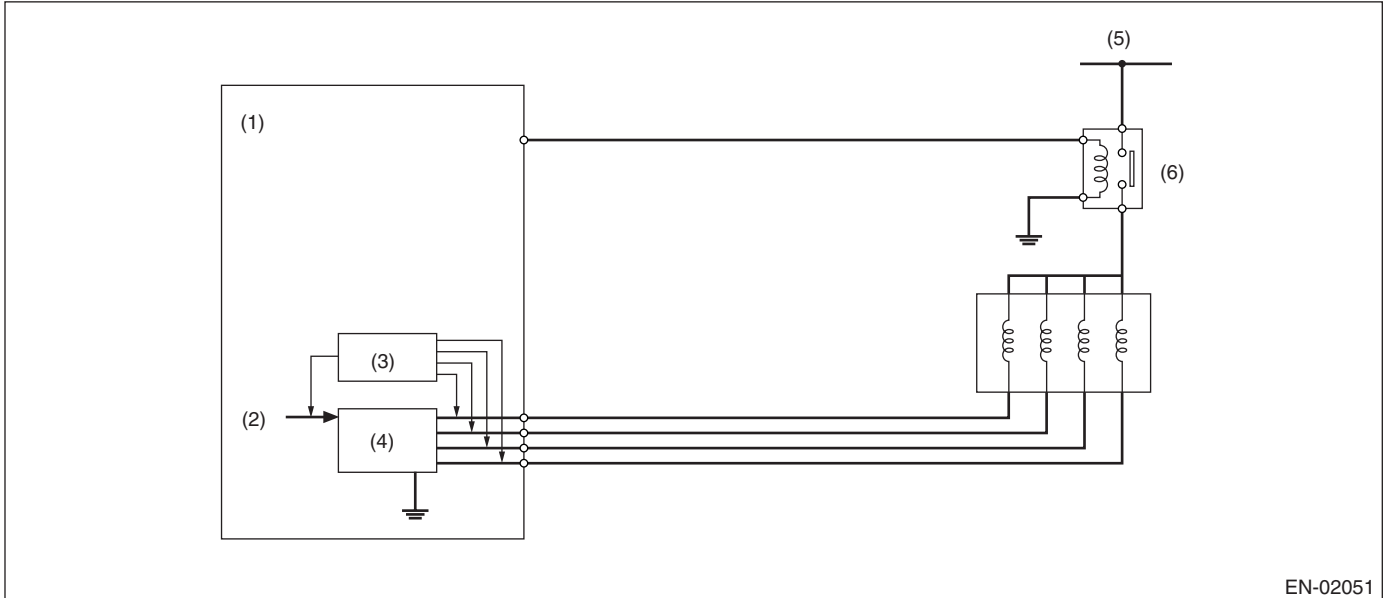

- (1) Engine Control Module (ECM)
- (2) CPU
- (3) Detecting circuit

- (4) Switching circuit
- (5) Battery voltage
- (6) Main relay

#### 3. ENABLE CONDITION

Secondary Parameters	Enable Conditions
Ignition switch	OFF
Battery voltage	> 10.9 V

#### 4. GENERAL DRIVING CYCLE

Always perform the diagnosis continuously.

#### 5. DIAGNOSTIC METHOD

##### • Abnormality Judgment

Judge NG when the cumulative time until completing the malfunction criteria below becomes more than time needed for diagnosis.

##### • Normality Judgement

Judge OK and clear the NG when the malfunction criteria below are not completed.

##### Judgment Value

Malfunction Criteria	Threshold Value	DTC	
Terminal voltage level when ECM outputs OFF signal	Low level	P1492 P1494	P1496 P1498
Terminal voltage level when ECM outputs ON signal	High level	P1493 P1495	P1497 P1499



# DIAGNOSTIC TROUBLE CODE (DTC) DETECTING CRITERIA

GENERAL DESCRIPTION

---

**Time Needed for Diagnosis:** 2.5 seconds

**Malfunction Indicator Light Illumination:** Illuminates as soon as the malfunction occurs.

## 6. DTC CLEAR CONDITION

- When the OK idling cycle is completed 40 times in a row
- When "Clear Memory" was performed

## 7. MALFUNCTION INDICATOR LIGHT CLEAR CONDITION

- When the OK driving cycle was completed 3 times in a row
- When "Clear Memory" was performed

## 8. FAIL SAFE

None

## 9. ECM OPERATION AT DTC

Memorize the freeze frame data. (For test mode \$02)

# DIAGNOSTIC TROUBLE CODE (DTC) DETECTING CRITERIA

## GENERAL DESCRIPTION

### DD:DTC P1494 — EGR SOLENOID VALVE SIGNAL #2 CIRCUIT MALFUNCTION (LOW INPUT) —

#### 1. OUTLINE OF DIAGNOSIS

- Detect the open/short circuit of EGR.
- Judge NG when ECM output level is different from actual terminal level.

#### 2. COMPONENT DESCRIPTION

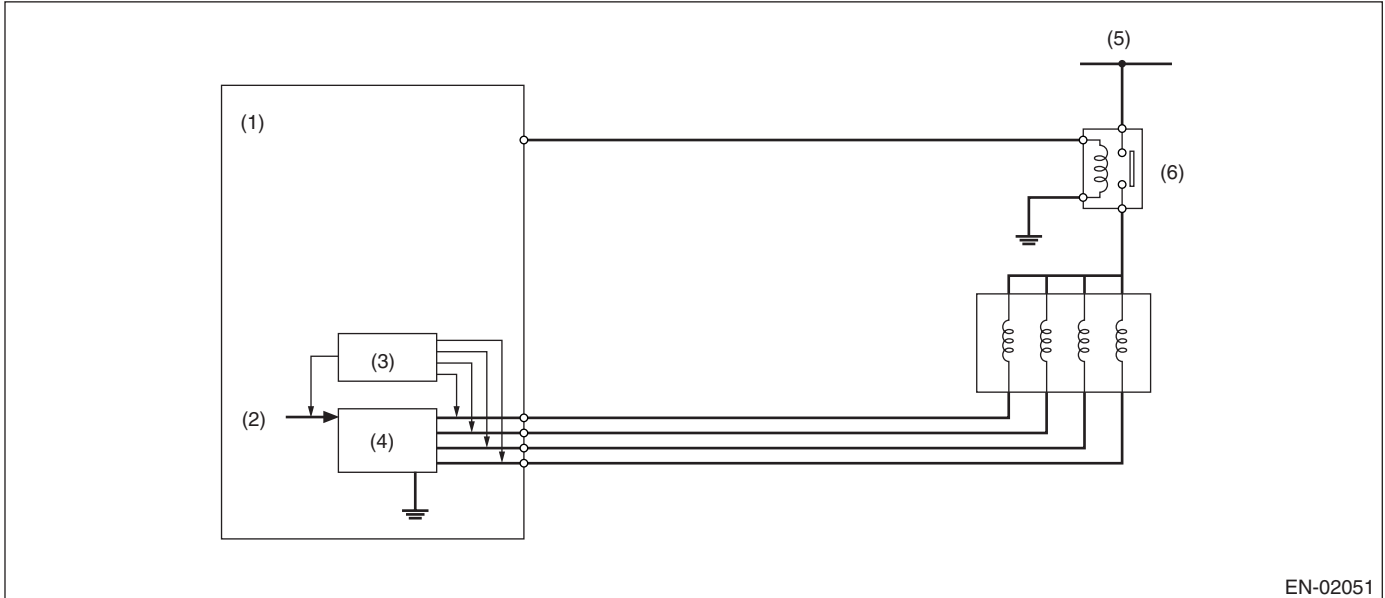

- (1) Engine Control Module (ECM)
- (2) CPU
- (3) Detecting circuit

- (4) Switching circuit
- (5) Battery voltage
- (6) Main relay

#### 3. ENABLE CONDITION

Secondary Parameters	Enable Conditions
Ignition switch	OFF
Battery voltage	> 10.9 V

#### 4. GENERAL DRIVING CYCLE

Always perform the diagnosis continuously.

#### 5. DIAGNOSTIC METHOD

##### • Abnormality Judgment

Judge NG when the cumulative time until completing the malfunction criteria below becomes more than time needed for diagnosis.

##### • Normality Judgement

Judge OK and clear the NG when the malfunction criteria below are not completed.

##### Judgment Value

Malfunction Criteria	Threshold Value	DTC	
Terminal voltage level when ECM outputs OFF signal	Low level	P1492	P1496
		P1494	P1498
Terminal voltage level when ECM outputs ON signal	High level	P1493	P1497
		P1495	P1499

# DIAGNOSTIC TROUBLE CODE (DTC) DETECTING CRITERIA

GENERAL DESCRIPTION

---

**Time Needed for Diagnosis:** 2.5 seconds

**Malfunction Indicator Light Illumination:** Illuminates as soon as the malfunction occurs.

## 6. DTC CLEAR CONDITION

- When the OK idling cycle is completed 40 times in a row
- When "Clear Memory" was performed

## 7. MALFUNCTION INDICATOR LIGHT CLEAR CONDITION

- When the OK driving cycle was completed 3 times in a row
- When "Clear Memory" was performed

## 8. FAIL SAFE

None

## 9. ECM OPERATION AT DTC

Memorize the freeze frame data. (For test mode \$02)

# DIAGNOSTIC TROUBLE CODE (DTC) DETECTING CRITERIA

## GENERAL DESCRIPTION

### DE:DTC P1495 — EGR SOLENOID VALVE SIGNAL #2 CIRCUIT MALFUNCTION (HIGH INPUT) —

#### 1. OUTLINE OF DIAGNOSIS

- Detect the open/short circuit of EGR.
- Judge NG when ECM output level is different from actual terminal level.

#### 2. COMPONENT DESCRIPTION

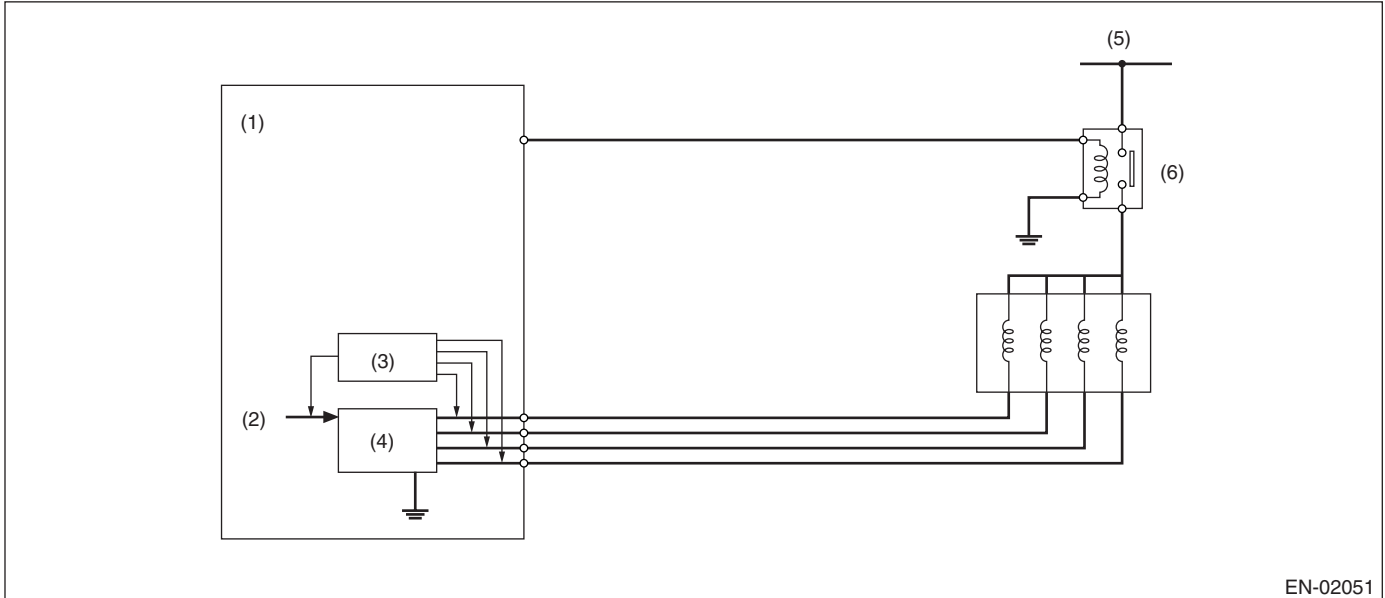

- (1) Engine Control Module (ECM)
- (2) CPU
- (3) Detecting circuit

- (4) Switching circuit
- (5) Battery voltage
- (6) Main relay

#### 3. ENABLE CONDITION

Secondary Parameters	Enable Conditions
Ignition switch	OFF
Battery voltage	> 10.9 V

#### 4. GENERAL DRIVING CYCLE

Always perform the diagnosis continuously.

#### 5. DIAGNOSTIC METHOD

##### • Abnormality Judgment

Judge NG when the cumulative time until completing the malfunction criteria below becomes more than time needed for diagnosis.

##### • Normality Judgement

Judge OK and clear the NG when the malfunction criteria below are not completed.

##### Judgment Value

Malfunction Criteria	Threshold Value	DTC	
Terminal voltage level when ECM outputs OFF signal	Low level	P1492	P1496
		P1494	P1498
Terminal voltage level when ECM outputs ON signal	High level	P1493	P1497
		P1495	P1499

# DIAGNOSTIC TROUBLE CODE (DTC) DETECTING CRITERIA

GENERAL DESCRIPTION

---

**Time Needed for Diagnosis:** 2.5 seconds

**Malfunction Indicator Light Illumination:** Illuminates as soon as the malfunction occurs.

## 6. DTC CLEAR CONDITION

- When the OK idling cycle is completed 40 times in a row
- When "Clear Memory" was performed

## 7. MALFUNCTION INDICATOR LIGHT CLEAR CONDITION

- When the OK driving cycle was completed 3 times in a row
- When "Clear Memory" was performed

## 8. FAIL SAFE

None

## 9. ECM OPERATION AT DTC

Memorize the freeze frame data. (For test mode \$02)

# DIAGNOSTIC TROUBLE CODE (DTC) DETECTING CRITERIA

## GENERAL DESCRIPTION

### DF:DTC P1496 — EGR SOLENOID VALVE SIGNAL #3 CIRCUIT MALFUNCTION (LOW INPUT) —

#### 1. OUTLINE OF DIAGNOSIS

- Detect the open/short circuit of EGR.
- Judge NG when ECM output level is different from actual terminal level.

#### 2. COMPONENT DESCRIPTION

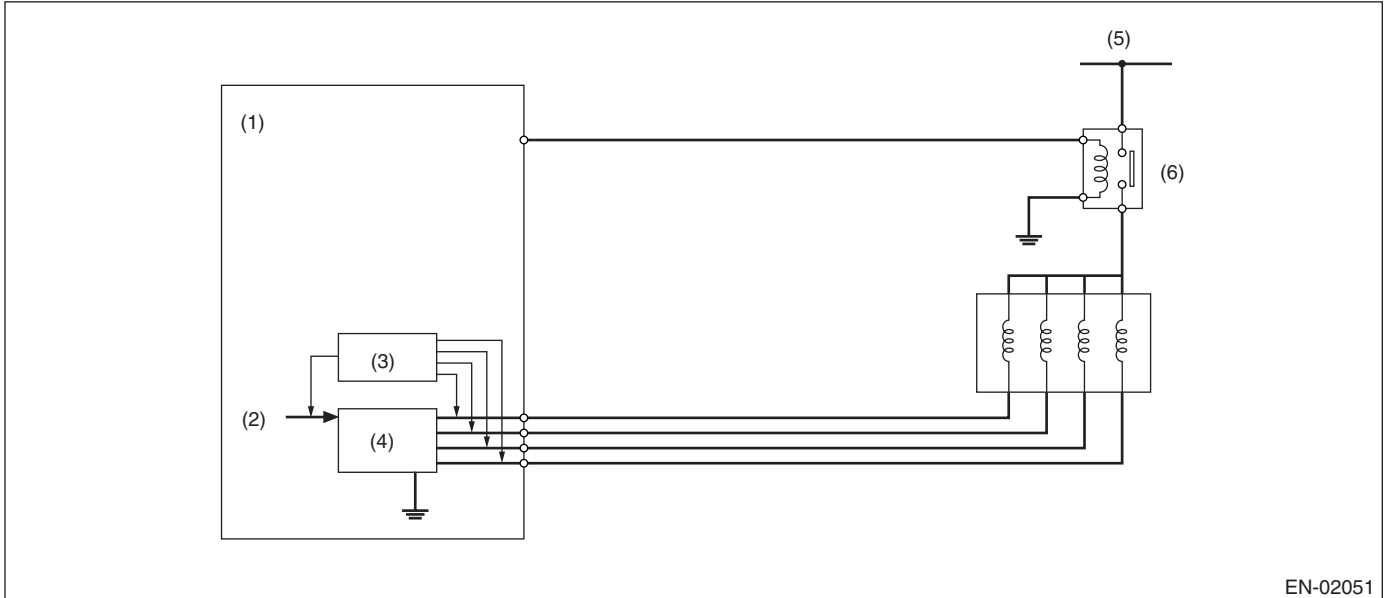

- (1) Engine Control Module (ECM)
- (2) CPU
- (3) Detecting circuit

- (4) Switching circuit
- (5) Battery voltage
- (6) Main relay

#### 3. ENABLE CONDITION

Secondary Parameters	Enable Conditions
Ignition switch	OFF
Battery voltage	> 10.9 V

#### 4. GENERAL DRIVING CYCLE

Always perform the diagnosis continuously.

#### 5. DIAGNOSTIC METHOD

##### • Abnormality Judgment

Judge NG when the cumulative time until completing the malfunction criteria below becomes more than time needed for diagnosis.

##### • Normality Judgement

Judge OK and clear the NG when the malfunction criteria below are not completed.

##### Judgment Value

Malfunction Criteria	Threshold Value	DTC	
Terminal voltage level when ECM outputs OFF signal	Low level	P1492	P1496
		P1494	P1498
Terminal voltage level when ECM outputs ON signal	High level	P1493	P1497
		P1495	P1499

# DIAGNOSTIC TROUBLE CODE (DTC) DETECTING CRITERIA

GENERAL DESCRIPTION

---

**Time Needed for Diagnosis:** 2.5 seconds

**Malfunction Indicator Light Illumination:** Illuminates as soon as the malfunction occurs.

## 6. DTC CLEAR CONDITION

- When the OK idling cycle is completed 40 times in a row
- When "Clear Memory" was performed

## 7. MALFUNCTION INDICATOR LIGHT CLEAR CONDITION

- When the OK driving cycle was completed 3 times in a row
- When "Clear Memory" was performed

## 8. FAIL SAFE

None

## 9. ECM OPERATION AT DTC

Memorize the freeze frame data. (For test mode \$02)

# DIAGNOSTIC TROUBLE CODE (DTC) DETECTING CRITERIA

## GENERAL DESCRIPTION

### DG:DTC P1497 — EGR SOLENOID VALVE SIGNAL #3 CIRCUIT MALFUNCTION (HIGH INPUT) —

#### 1. OUTLINE OF DIAGNOSIS

- Detect the open/short circuit of EGR.
- Judge NG when ECM output level is different from actual terminal level.

#### 2. COMPONENT DESCRIPTION

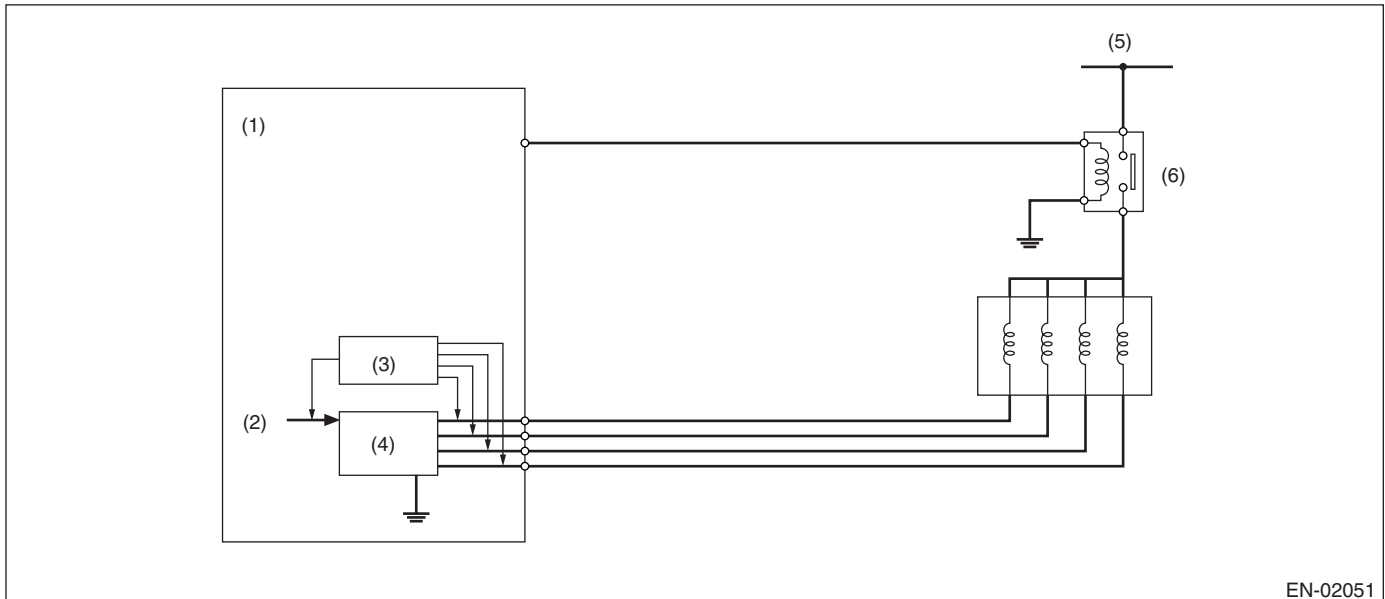

EN-02051

- (1) Engine Control Module (ECM)
- (2) CPU
- (3) Detecting circuit

- (4) Switching circuit
- (5) Battery voltage
- (6) Main relay

#### 3. ENABLE CONDITION

Secondary Parameters	Enable Conditions
Ignition switch	OFF
Battery voltage	> 10.9 V

#### 4. GENERAL DRIVING CYCLE

Always perform the diagnosis continuously.

#### 5. DIAGNOSTIC METHOD

##### • Abnormality Judgment

Judge NG when the cumulative time until completing the malfunction criteria below becomes more than time needed for diagnosis.

##### • Normality Judgement

Judge OK and clear the NG when the malfunction criteria below are not completed.

##### Judgment Value

Malfunction Criteria	Threshold Value	DTC	
Terminal voltage level when ECM outputs OFF signal	Low level	P1492 P1494	P1496 P1498
Terminal voltage level when ECM outputs ON signal	High level	P1493 P1495	P1497 P1499



# DIAGNOSTIC TROUBLE CODE (DTC) DETECTING CRITERIA

GENERAL DESCRIPTION

---

**Time Needed for Diagnosis:** 2.5 seconds

**Malfunction Indicator Light Illumination:** Illuminates as soon as the malfunction occurs.

## 6. DTC CLEAR CONDITION

- When the OK idling cycle is completed 40 times in a row
- When "Clear Memory" was performed

## 7. MALFUNCTION INDICATOR LIGHT CLEAR CONDITION

- When the OK driving cycle was completed 3 times in a row
- When "Clear Memory" was performed

## 8. FAIL SAFE

None

## 9. ECM OPERATION AT DTC

Memorize the freeze frame data. (For test mode \$02)

# DIAGNOSTIC TROUBLE CODE (DTC) DETECTING CRITERIA

## GENERAL DESCRIPTION

### DH:DTC P1498 — EGR SOLENOID VALVE SIGNAL #4 CIRCUIT MALFUNCTION (LOW INPUT) —

#### 1. OUTLINE OF DIAGNOSIS

- Detect the open/short circuit of EGR.
- Judge NG when ECM output level is different from actual terminal level.

#### 2. COMPONENT DESCRIPTION

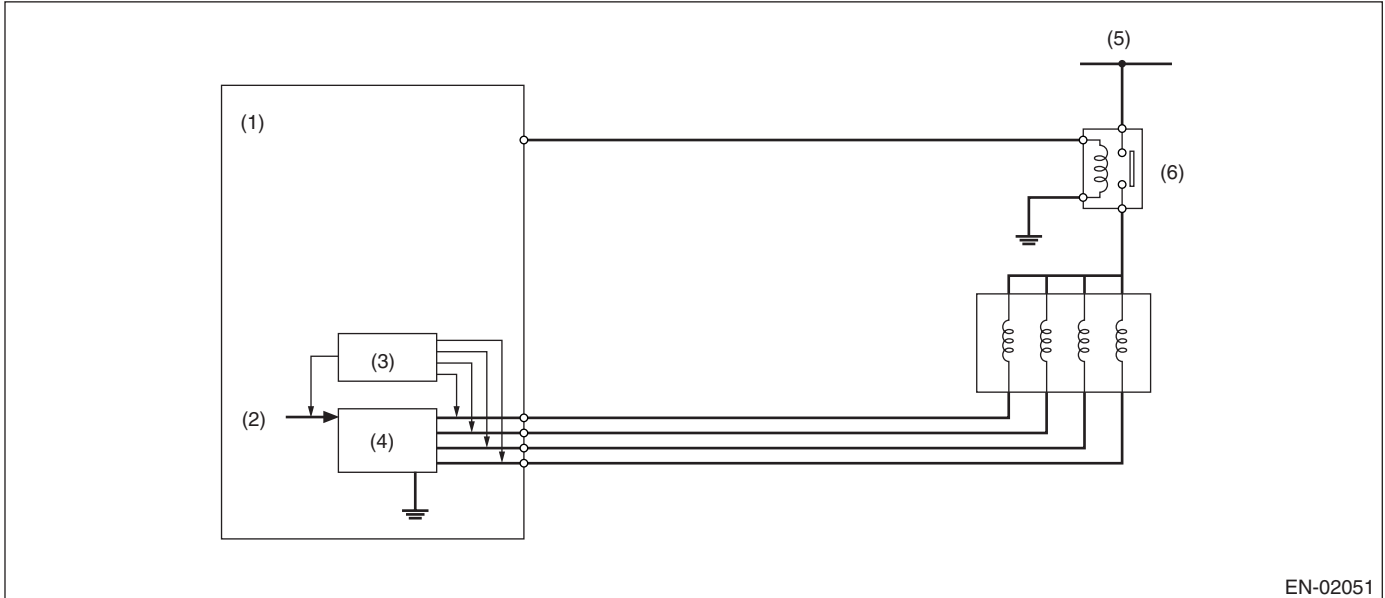

- (1) Engine Control Module (ECM)
- (2) CPU
- (3) Detecting circuit

- (4) Switching circuit
- (5) Battery voltage
- (6) Main relay

#### 3. ENABLE CONDITION

Secondary Parameters	Enable Conditions
Ignition switch	OFF
Battery voltage	> 10.9 V

#### 4. GENERAL DRIVING CYCLE

Always perform the diagnosis continuously.

#### 5. DIAGNOSTIC METHOD

##### • Abnormality Judgment

Judge NG when the cumulative time until completing the malfunction criteria below becomes more than time needed for diagnosis.

##### • Normality Judgement

Judge OK and clear the NG when the malfunction criteria below are not completed.

##### Judgment Value

Malfunction Criteria	Threshold Value	DTC	
Terminal voltage level when ECM outputs OFF signal	Low level	P1492	P1496
		P1494	P1498
Terminal voltage level when ECM outputs ON signal	High level	P1493	P1497
		P1495	P1499

# DIAGNOSTIC TROUBLE CODE (DTC) DETECTING CRITERIA

GENERAL DESCRIPTION

---

**Time Needed for Diagnosis:** 2.5 seconds

**Malfunction Indicator Light Illumination:** Illuminates as soon as the malfunction occurs.

## 6. DTC CLEAR CONDITION

- When the OK idling cycle is completed 40 times in a row
- When "Clear Memory" was performed

## 7. MALFUNCTION INDICATOR LIGHT CLEAR CONDITION

- When the OK driving cycle was completed 3 times in a row
- When "Clear Memory" was performed

## 8. FAIL SAFE

None

## 9. ECM OPERATION AT DTC

Memorize the freeze frame data. (For test mode \$02)

# DIAGNOSTIC TROUBLE CODE (DTC) DETECTING CRITERIA

## GENERAL DESCRIPTION

### DI: DTC P1499 — EGR SOLENOID VALVE SIGNAL #4 CIRCUIT MALFUNCTION (HIGH INPUT) —

#### 1. OUTLINE OF DIAGNOSIS

- Detect the open/short circuit of EGR.
- Judge NG when ECM output level is different from actual terminal level.

#### 2. COMPONENT DESCRIPTION

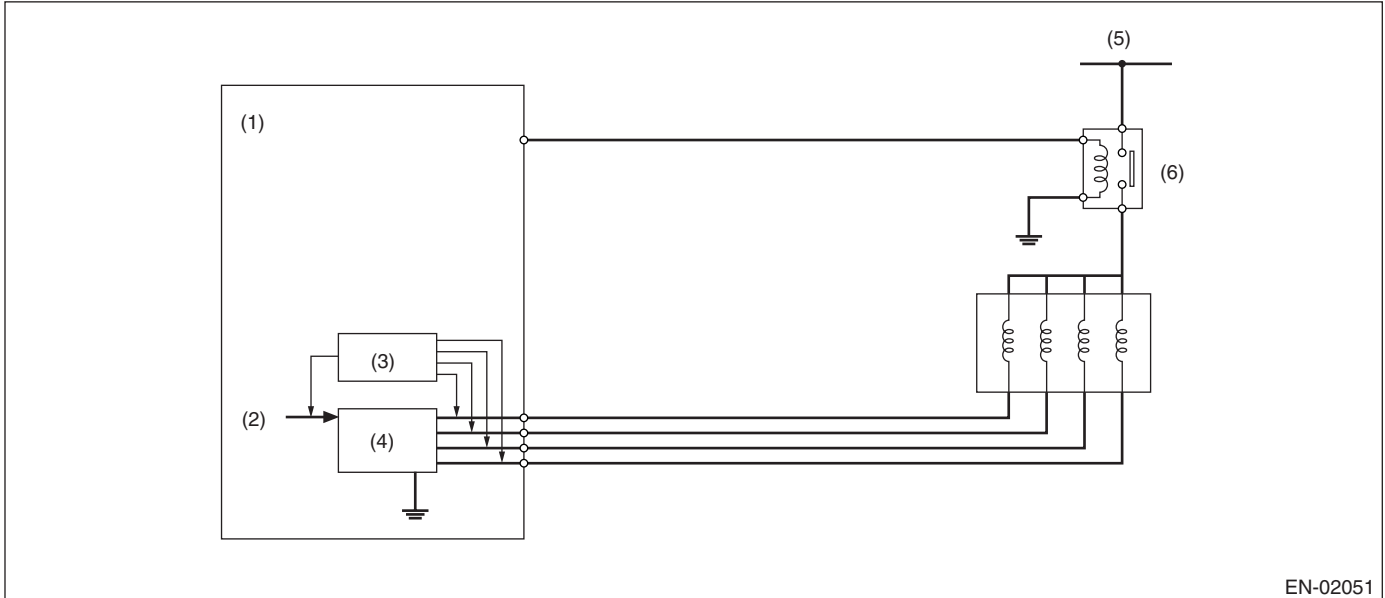

- (1) Engine Control Module (ECM)
- (2) CPU
- (3) Detecting circuit

- (4) Switching circuit
- (5) Battery voltage
- (6) Main relay

#### 3. ENABLE CONDITION

Secondary Parameters	Enable Conditions
Ignition switch	OFF
Battery voltage	> 10.9 V

#### 4. GENERAL DRIVING CYCLE

Always perform the diagnosis continuously.

#### 5. DIAGNOSTIC METHOD

##### • Abnormality Judgment

Judge NG when the cumulative time until completing the malfunction criteria below becomes more than time needed for diagnosis.

##### • Normality Judgement

Judge OK and clear the NG when the malfunction criteria below are not completed.

##### Judgment Value

Malfunction Criteria	Threshold Value	DTC	
Terminal voltage level when ECM outputs OFF signal	Low level	P1492	P1496
		P1494	P1498
Terminal voltage level when ECM outputs ON signal	High level	P1493	P1497
		P1495	P1499

# DIAGNOSTIC TROUBLE CODE (DTC) DETECTING CRITERIA

GENERAL DESCRIPTION

---

**Time Needed for Diagnosis:** 2.5 seconds

**Malfunction Indicator Light Illumination:** Illuminates as soon as the malfunction occurs.

## 6. DTC CLEAR CONDITION

- When the OK idling cycle is completed 40 times in a row
- When "Clear Memory" was performed

## 7. MALFUNCTION INDICATOR LIGHT CLEAR CONDITION

- When the OK driving cycle was completed 3 times in a row
- When "Clear Memory" was performed

## 8. FAIL SAFE

None

## 9. ECM OPERATION AT DTC

Memorize the freeze frame data. (For test mode \$02)

# DIAGNOSTIC TROUBLE CODE (DTC) DETECTING CRITERIA

## GENERAL DESCRIPTION

### DJ:DTC P1510 — ISC SOLENOID VALVE SIGNAL #1 CIRCUIT MALFUNCTION (LOW INPUT) —

#### 1. OUTLINE OF DIAGNOSIS

- Detect the open/short circuit of idle air control solenoid valve.
- Judge NG when the output terminal is Low level even though ECM outputs OFF signal.

#### 2. COMPONENT DESCRIPTION

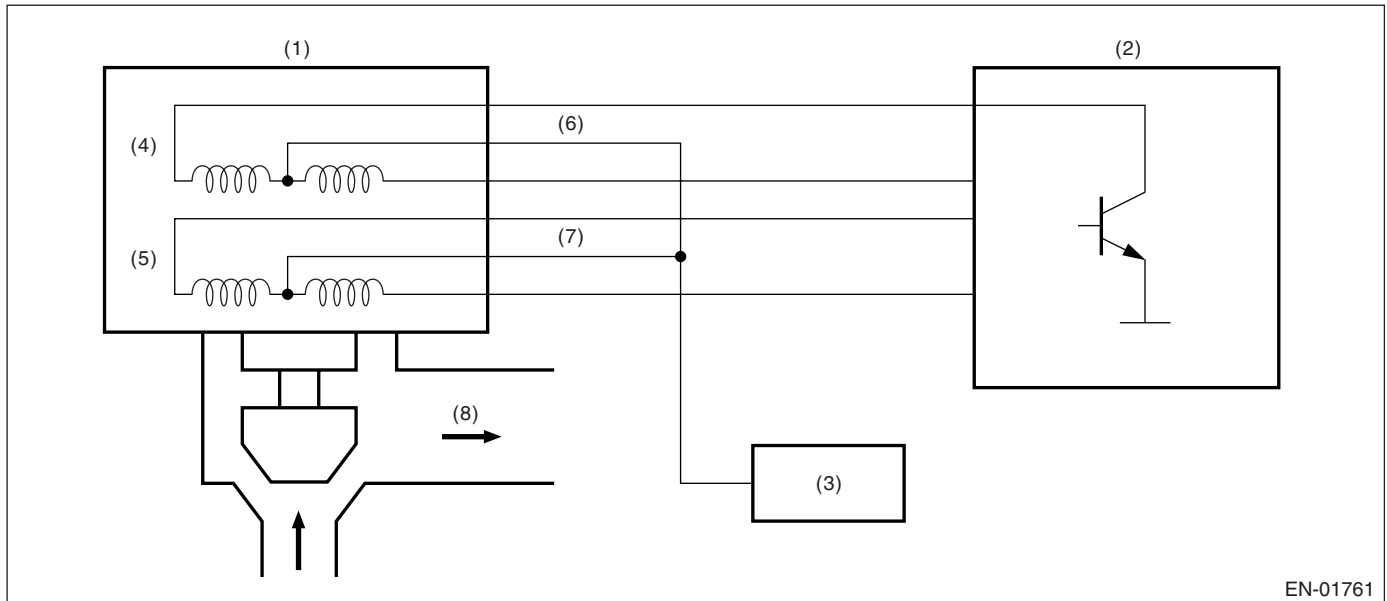

- (1) Idle air control solenoid valve
- (2) Engine control module (ECM)
- (3) Ignition relay
- (4) A phase

- (5) B phase
- (6) A phase power
- (7) B phase power
- (8) Intake air

#### 3. ENABLE CONDITION

Secondary Parameters	Enable Conditions
Ignition switch	OFF
Battery voltage	> 10.9 V

#### 4. GENERAL DRIVING CYCLE

Perform the diagnosis when starter switch is OFF.

#### 5. DIAGNOSTIC METHOD

##### • Abnormality Judgment

Judge NG when the cumulative time until completing the malfunction criteria below becomes more than time needed for diagnosis.

##### Judgment Value

Malfunction Criteria	Threshold Value
Terminal voltage level when ECM outputs OFF signal	Low level

**Time Needed for Diagnosis:** 0.5 seconds

**Malfunction Indicator Light Illumination:** Illuminates as soon as malfunction occurs.

# DIAGNOSTIC TROUBLE CODE (DTC) DETECTING CRITERIA

GENERAL DESCRIPTION

## • Normality Judgment

Judge OK and clear the NG when the malfunction criteria below are completed.

### Judgment Value

Malfunction Criteria	Threshold Value
Terminal voltage level when ECM outputs OFF signal	High level

## 6. DTC CLEAR CONDITION

- When the OK idling cycle is completed 40 times in a row
- When "Clear Memory" was performed

## 7. MALFUNCTION INDICATOR LIGHT CLEAR CONDITION

- When the OK driving cycle was completed 3 times in a row
- When "Clear Memory" was performed

## 8. FAIL SAFE

- Cut the fuel of all cylinders, #1 cylinder or #1, #2 cylinder according to throttle position, engine speed, vehicle speed.
- ISC closed loop compensation value becomes zero. [ISCCL = 0 (l/min)]

## 9. ECM OPERATION AT DTC

Memorize the freeze frame data. (For test mode \$02)

# DIAGNOSTIC TROUBLE CODE (DTC) DETECTING CRITERIA

## GENERAL DESCRIPTION

### DK:DTC P1511 — ISC SOLENOID VALVE SIGNAL #1 CIRCUIT MALFUNCTION (HIGH INPUT) —

#### 1. OUTLINE OF DIAGNOSIS

- Detect the open/short circuit of idle air control solenoid valve.
- Judge NG when the output terminal is High level even though ECM outputs ON signal.

#### 2. COMPONENT DESCRIPTION

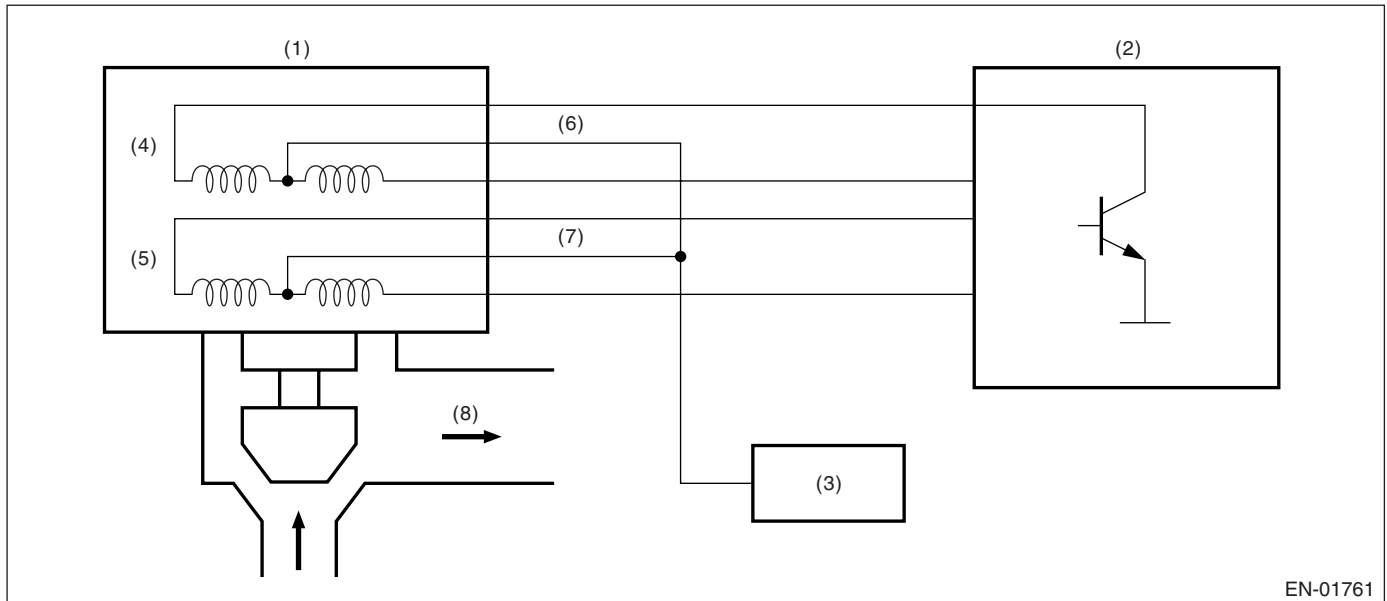

- (1) Idle air control solenoid valve
- (2) Engine control module (ECM)
- (3) Ignition relay
- (4) A phase

- (5) B phase
- (6) A phase power
- (7) B phase power
- (8) Intake air

#### 3. ENABLE CONDITION

Secondary Parameters	Enable Conditions
Starter switch	OFF
Battery voltage	> 10.9 V

#### 4. GENERAL DRIVING CYCLE

Perform the diagnosis continuously when starter switch is OFF.

#### 5. DIAGNOSTIC METHOD

##### • Abnormality Judgment

Judge NG when the cumulative time until completing the malfunction criteria below becomes more than time needed for diagnosis.

##### Judgment Value

Malfunction Criteria	Threshold Value
Terminal voltage level when ECM outputs ON signal	High level

**Time needed for diagnosis:** 0.5 seconds

**Malfunction Indicator Light Illumination:** Illuminates as soon as malfunction occurs.



# DIAGNOSTIC TROUBLE CODE (DTC) DETECTING CRITERIA

GENERAL DESCRIPTION

## • Normality Judgment

Judge OK and clear the NG when the malfunction criteria below are completed.

### Judgment Value

Malfunction Criteria	Threshold Value
Terminal voltage level when ECM outputs ON signal	Low level

## 6. DTC CLEAR CONDITION

- When the OK idling cycle is completed 40 times in a row
- When "Clear Memory" was performed

## 7. MALFUNCTION INDICATOR LIGHT CLEAR CONDITION

- When the OK driving cycle was completed 3 times in a row
- When "Clear Memory" was performed

## 8. FAIL SAFE

- Cut the fuel of all cylinders, #1 cylinder or #1, #2 cylinder according to throttle position, engine speed, vehicle speed.
- ISC closed loop compensation value becomes zero. [ISCCL = 0 (l/min)]

## 9. ECM OPERATION AT DTC

Memorize the freeze frame data. (For test mode \$02)

# DIAGNOSTIC TROUBLE CODE (DTC) DETECTING CRITERIA

## GENERAL DESCRIPTION

### DL:DTC P1512 — ISC SOLENOID VALVE SIGNAL #2 CIRCUIT MALFUNCTION (LOW INPUT) —

#### 1. OUTLINE OF DIAGNOSIS

- Detect the open/short circuit of idle air control solenoid valve.
- Judge NG when the output terminal is Low level even though ECM outputs OFF signal.

#### 2. COMPONENT DESCRIPTION

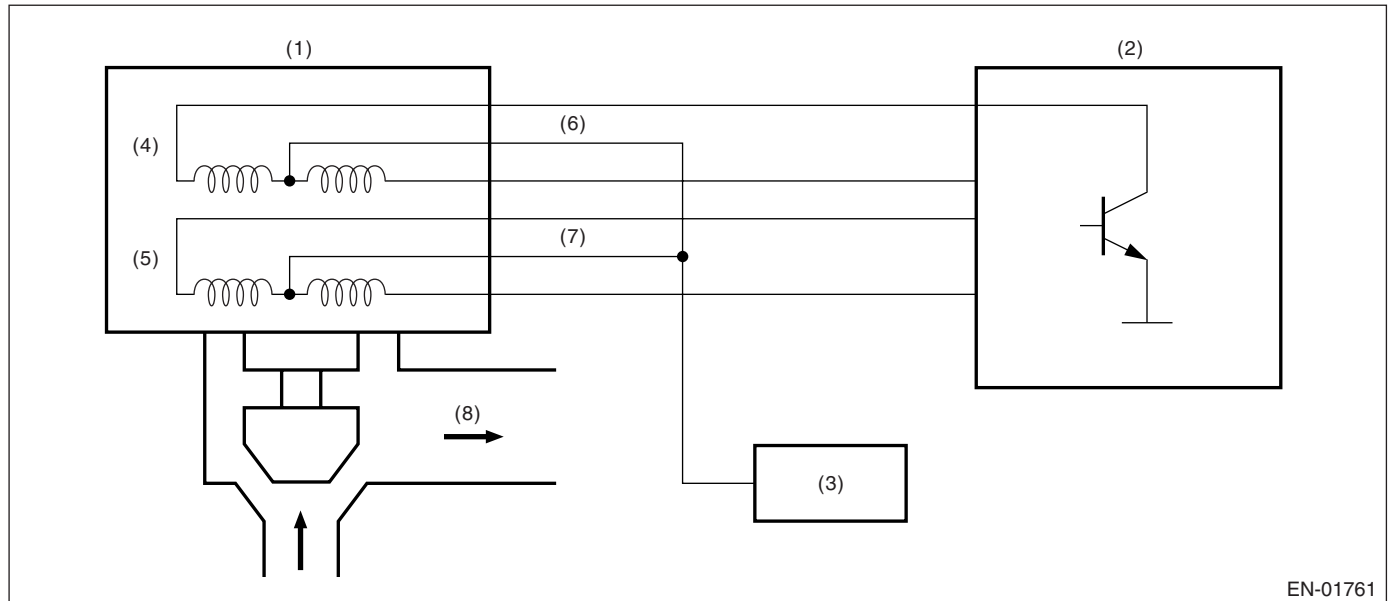

- (1) Idle air control solenoid valve
- (2) Engine control module (ECM)
- (3) Ignition relay
- (4) A phase

- (5) B phase
- (6) A phase power
- (7) B phase power
- (8) Intake air

#### 3. ENABLE CONDITION

Secondary Parameters	Enable Conditions
Starter switch	OFF
Battery voltage	> 10.9 V

#### 4. GENERAL DRIVING CYCLE

Perform the diagnosis continuously when starter switch is OFF.

#### 5. DIAGNOSTIC METHOD

##### • Abnormality Judgment

Judge NG when the cumulative time until completing the malfunction criteria below becomes more than time needed for diagnosis.

##### Judgment Value

Malfunction Criteria	Threshold Value
Terminal voltage level when ECM outputs OFF signal	Low level

**Time Needed for Diagnosis:** 0.5 seconds

**Malfunction Indicator Light Illumination:** Illuminates as soon as malfunction occurs.

# DIAGNOSTIC TROUBLE CODE (DTC) DETECTING CRITERIA

GENERAL DESCRIPTION

## • Normality Judgment

Judge OK and clear the NG when the malfunction criteria below are completed.

### Judgment Value

Malfunction Criteria	Threshold Value
Terminal voltage level when ECM outputs OFF signal	High level

## 6. DTC CLEAR CONDITION

- When the OK idling cycle is completed 40 times in a row
- When "Clear Memory" was performed

## 7. MALFUNCTION INDICATOR LIGHT CLEAR CONDITION

- When the OK driving cycle was completed 3 times in a row
- When "Clear Memory" was performed

## 8. FAIL SAFE

- Cut the fuel of all cylinders, #1 cylinder or #1, #2 cylinder according to throttle position, engine speed, vehicle speed.
- ISC closed loop compensation value becomes zero. [ISCCL = 0 (l/min)]

## 9. ECM OPERATION AT DTC

Memorize the freeze frame data. (For test mode \$02)

# DIAGNOSTIC TROUBLE CODE (DTC) DETECTING CRITERIA

## GENERAL DESCRIPTION

### DM:DTC P1513 — ISC SOLENOID VALVE SIGNAL #2 CIRCUIT MALFUNCTION (HIGH INPUT) —

#### 1. OUTLINE OF DIAGNOSIS

- Detect the open/short circuit of idle air control solenoid valve.
- Judge NG when the output terminal is High level even though ECM outputs ON signal.

#### 2. COMPONENT DESCRIPTION

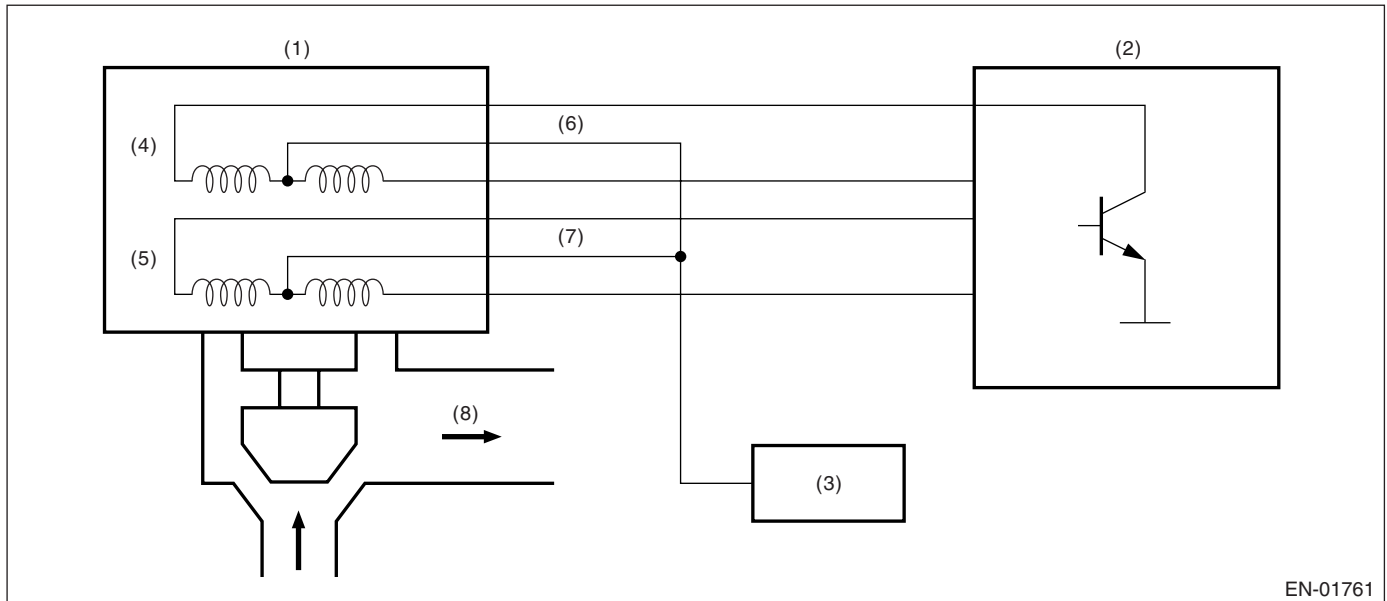

EN-01761

- |                                     |                   |
|-------------------------------------|-------------------|
| (1) Idle air control solenoid valve | (5) B phase       |
| (2) Engine control module (ECM)     | (6) A phase power |
| (3) Ignition relay                  | (7) B phase power |
| (4) A phase                         | (8) Intake air    |

#### 3. ENABLE CONDITION

Secondary Parameters	Enable Conditions
Starter switch	OFF
Battery voltage	> 10.9 V

#### 4. GENERAL DRIVING CYCLE

Perform the diagnosis continuously when starter switch is OFF.

#### 5. DIAGNOSTIC METHOD

##### • Abnormality Judgment

Judge NG when the cumulative time until completing the malfunction criteria below becomes more than time needed for diagnosis.

##### Judgment Value

Malfunction Criteria	Threshold Value
Terminal voltage level when ECM outputs ON signal	High level

**Time Needed for Diagnosis:** 0.5 seconds

**Malfunction Indicator Light Illumination:** Illuminates as soon as malfunction occurs.

# DIAGNOSTIC TROUBLE CODE (DTC) DETECTING CRITERIA

GENERAL DESCRIPTION

## • Normality Judgment

Judge OK and clear the NG when the malfunction criteria below are completed.

### Judgment Value

Malfunction Criteria	Threshold Value
Terminal voltage level when ECM outputs ON signal	Low level

## 6. DTC CLEAR CONDITION

- When the OK idling cycle is completed 40 times in a row
- When "Clear Memory" was performed

## 7. MALFUNCTION INDICATOR LIGHT CLEAR CONDITION

- When the OK driving cycle was completed 3 times in a row
- When "Clear Memory" was performed

## 8. FAIL SAFE

- Cut the fuel of all cylinders, #1 cylinder or #1, #2 cylinder according to throttle position, engine speed, vehicle speed.
- ISC closed loop compensation value becomes zero. [ISCCL = 0 (l/min)]

## 9. ECM OPERATION AT DTC

Memorize the freeze frame data. (For test mode \$02)

# DIAGNOSTIC TROUBLE CODE (DTC) DETECTING CRITERIA

## GENERAL DESCRIPTION

### DN:DTC P1514 — ISC SOLENOID VALVE SIGNAL #3 CIRCUIT MALFUNCTION (LOW INPUT) —

#### 1. OUTLINE OF DIAGNOSIS

- Detect the open/short circuit of idle air control solenoid valve.
- Judge NG when the output terminal is Low level even though ECM outputs OFF signal.

#### 2. COMPONENT DESCRIPTION

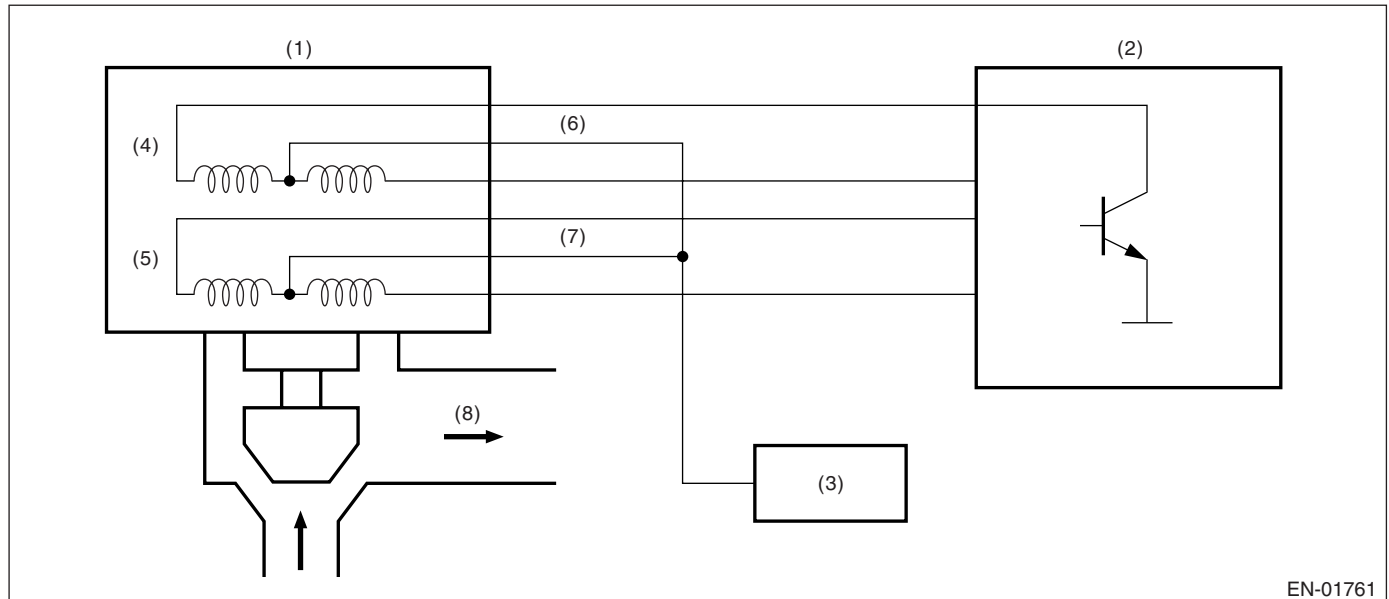

- (1) Idle air control solenoid valve
- (2) Engine control module (ECM)
- (3) Ignition relay
- (4) A phase

- (5) B phase
- (6) A phase power
- (7) B phase power
- (8) Intake air

#### 3. ENABLE CONDITION

Secondary Parameters	Enable Conditions
Starter switch	OFF
Battery voltage	> 10.9 V

#### 4. GENERAL DRIVING CYCLE

Perform the diagnosis continuously when starter switch is OFF.

#### 5. DIAGNOSTIC METHOD

##### • Abnormality Judgment

Judge NG when the cumulative time until completing the malfunction criteria below becomes more than time needed for diagnosis.

##### Judgment Value

Malfunction Criteria	Threshold Value
Terminal voltage level when ECM outputs OFF signal	Low level

**Time Needed for Diagnosis:** 0.5 seconds

**Malfunction Indicator Light Illumination:** Illuminates as soon as malfunction occurs.

# DIAGNOSTIC TROUBLE CODE (DTC) DETECTING CRITERIA

GENERAL DESCRIPTION

## • Normality Judgment

Judge OK and clear the NG when the malfunction criteria below are completed.

### Judgment Value

Malfunction Criteria	Threshold Value
Terminal voltage level when ECM outputs OFF signal	High level

## 6. DTC CLEAR CONDITION

- When the OK idling cycle is completed 40 times in a row
- When "Clear Memory" was performed

## 7. MALFUNCTION INDICATOR LIGHT CLEAR CONDITION

- When the OK driving cycle was completed 3 times in a row
- When "Clear Memory" was performed

## 8. FAIL SAFE

- Cut the fuel of all cylinders, #1 cylinder or #1, #2 cylinder according to throttle position, engine speed, vehicle speed.
- ISC closed loop compensation value becomes zero. [ISCCL = 0 (l/min)]

## 9. ECM OPERATION AT DTC

Memorize the freeze frame data. (For test mode \$02)

# DIAGNOSTIC TROUBLE CODE (DTC) DETECTING CRITERIA

## GENERAL DESCRIPTION

### DO:DTC P1515 — ISC SOLENOID VALVE SIGNAL #3 CIRCUIT MALFUNCTION (HIGH INPUT) —

#### 1. OUTLINE OF DIAGNOSIS

- Detect the open/short circuit of idle air control solenoid valve.
- Judge NG when the output terminal is High level even though ECM outputs ON signal.

#### 2. COMPONENT DESCRIPTION

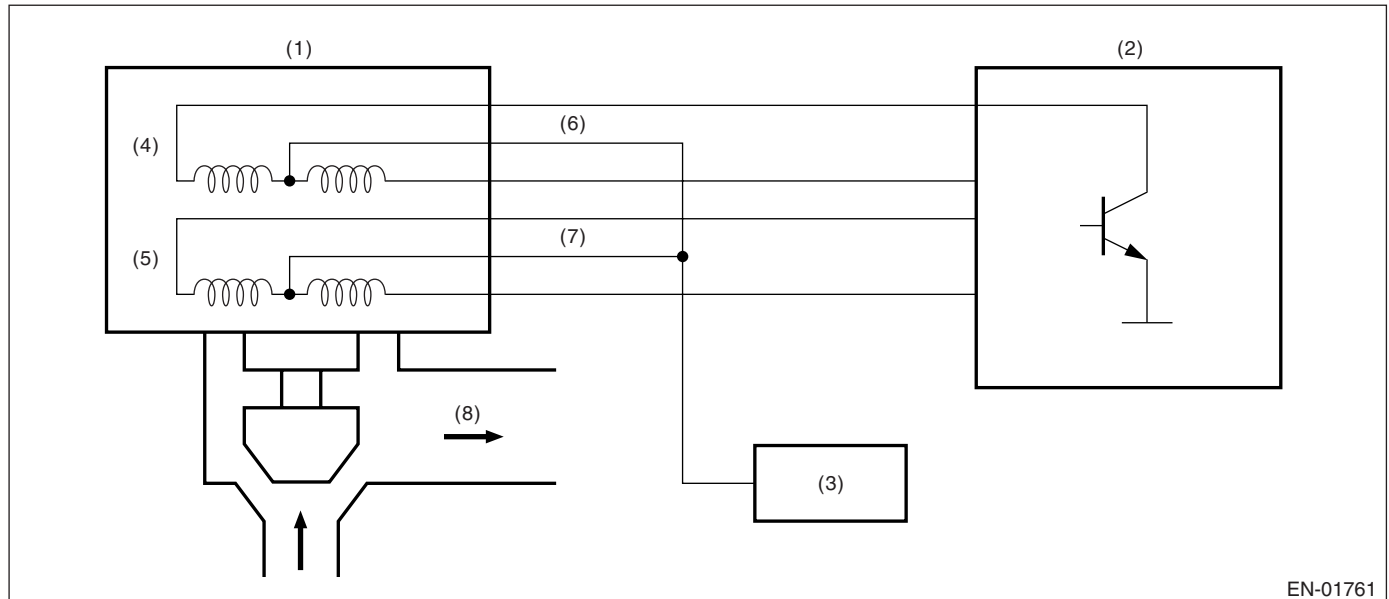

- (1) Idle air control solenoid valve
- (2) Engine control module (ECM)
- (3) Ignition relay
- (4) A phase

- (5) B phase
- (6) A phase power
- (7) B phase power
- (8) Intake air

#### 3. ENABLE CONDITION

Secondary Parameters	Enable Conditions
Starter switch	OFF
Battery voltage	> 10.9 V

#### 4. GENERAL DRIVING CYCLE

Perform the diagnosis continuously when starter switch is OFF.

#### 5. DIAGNOSTIC METHOD

##### • Abnormality Judgment

Judge NG when the cumulative time until completing the malfunction criteria below becomes more than time needed for diagnosis.

##### Judgment Value

Malfunction Criteria	Threshold Value
Terminal voltage level when ECM outputs ON signal	High level

**Time Needed for Diagnosis:** 0.5 seconds

**Malfunction Indicator Light Illumination:** Illuminates as soon as malfunction occurs.



# DIAGNOSTIC TROUBLE CODE (DTC) DETECTING CRITERIA

GENERAL DESCRIPTION

## • Normality Judgment

Judge OK and clear the NG when the malfunction criteria below are completed.

### Judgment Value

Malfunction Criteria	Threshold Value
Terminal voltage level when ECM outputs ON signal	Low level

## 6. DTC CLEAR CONDITION

- When the OK idling cycle is completed 40 times in a row
- When "Clear Memory" was performed

## 7. MALFUNCTION INDICATOR LIGHT CLEAR CONDITION

- When the OK driving cycle was completed 3 times in a row
- When "Clear Memory" was performed

## 8. FAIL SAFE

- Cut the fuel of all cylinders, #1 cylinder or #1, #2 cylinder according to throttle position, engine speed, vehicle speed.
- ISC closed loop compensation value becomes zero. [ISCCL = 0 (l/min)]

## 9. ECM OPERATION AT DTC

Memorize the freeze frame data. (For test mode \$02)

# DIAGNOSTIC TROUBLE CODE (DTC) DETECTING CRITERIA

## GENERAL DESCRIPTION

### DP:DTC P1516 — ISC SOLENOID VALVE SIGNAL #4 CIRCUIT MALFUNCTION (LOW INPUT) —

#### 1. OUTLINE OF DIAGNOSIS

- Detect the open/short circuit of idle air control solenoid valve.
- Judge NG when the output terminal is Low level even though ECM outputs OFF signal.

#### 2. COMPONENT DESCRIPTION

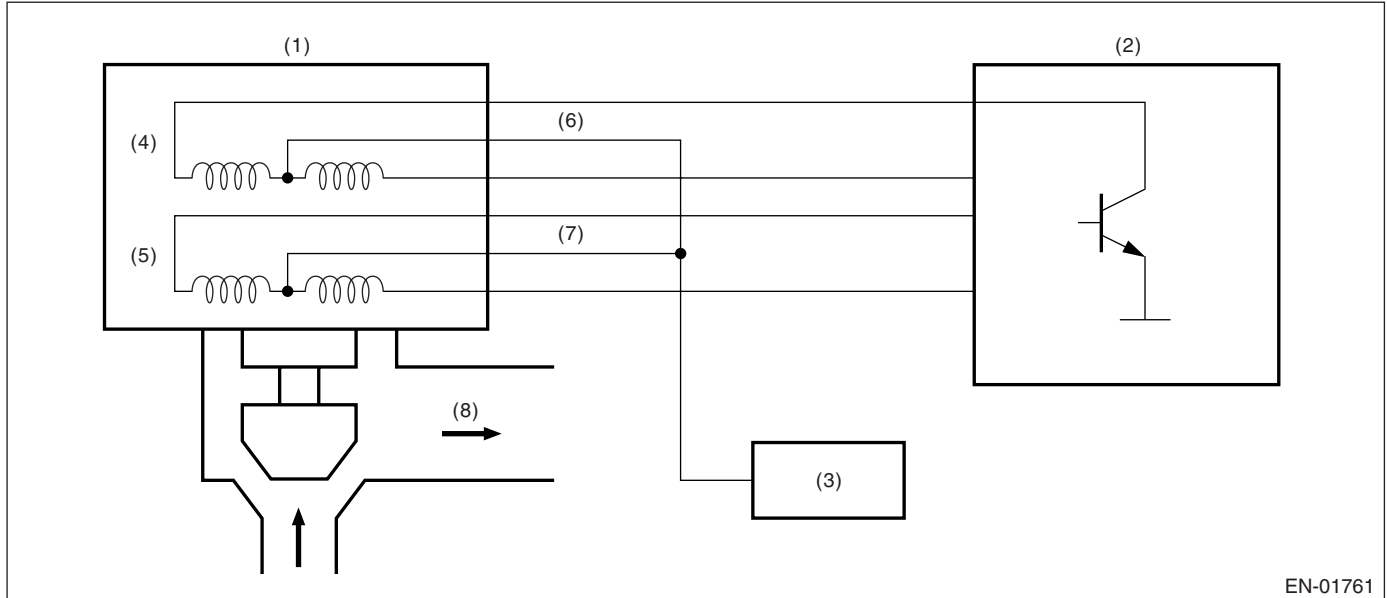

- (1) Idle air control solenoid valve
- (2) Engine control module (ECM)
- (3) Ignition relay
- (4) A phase

- (5) B phase
- (6) A phase power
- (7) B phase power
- (8) Intake air

#### 3. ENABLE CONDITION

Secondary Parameters	Enable Conditions
Starter switch	OFF
Battery voltage	> 10.9 V

#### 4. GENERAL DRIVING CYCLE

Perform the diagnosis continuously when starter switch is OFF.

#### 5. DIAGNOSTIC METHOD

##### • Abnormality Judgment

Judge NG when the cumulative time until completing the malfunction criteria below becomes more than time needed for diagnosis.

##### Judgment Value

Malfunction Criteria	Threshold Value
Terminal voltage level when ECM outputs OFF signal	Low level

**Time Needed for Diagnosis:** 0.5 seconds

**Malfunction Indicator Light Illumination:** Illuminates as soon as malfunction occurs.

# DIAGNOSTIC TROUBLE CODE (DTC) DETECTING CRITERIA

GENERAL DESCRIPTION

## • Normality Judgment

Judge OK and clear the NG when the malfunction criteria below are completed.

### Judgment Value

Malfunction Criteria	Threshold Value
Terminal voltage level when ECM outputs OFF signal	High level

## 6. DTC CLEAR CONDITION

- When the OK idling cycle is completed 40 times in a row
- When "Clear Memory" was performed

## 7. MALFUNCTION INDICATOR LIGHT CLEAR CONDITION

- When the OK driving cycle was completed 3 times in a row
- When "Clear Memory" was performed

## 8. FAIL SAFE

- Cut the fuel of all cylinders, #1 cylinder or #1, #2 cylinder according to throttle position, engine speed, vehicle speed.
- ISC closed loop compensation value becomes zero. [ISCCL = 0 (1/min)]

## 9. ECM OPERATION AT DTC

Memorize the freeze frame data. (For test mode \$02)

# DIAGNOSTIC TROUBLE CODE (DTC) DETECTING CRITERIA

## GENERAL DESCRIPTION

### DQ:DTC P1517 — ISC SOLENOID VALVE SIGNAL #4 CIRCUIT MALFUNCTION (HIGH INPUT) —

#### 1. OUTLINE OF DIAGNOSIS

- Detect the open/short circuit of idle air control solenoid valve.
- Judge NG when the output terminal is High level even though ECM outputs ON signal.

#### 2. COMPONENT DESCRIPTION

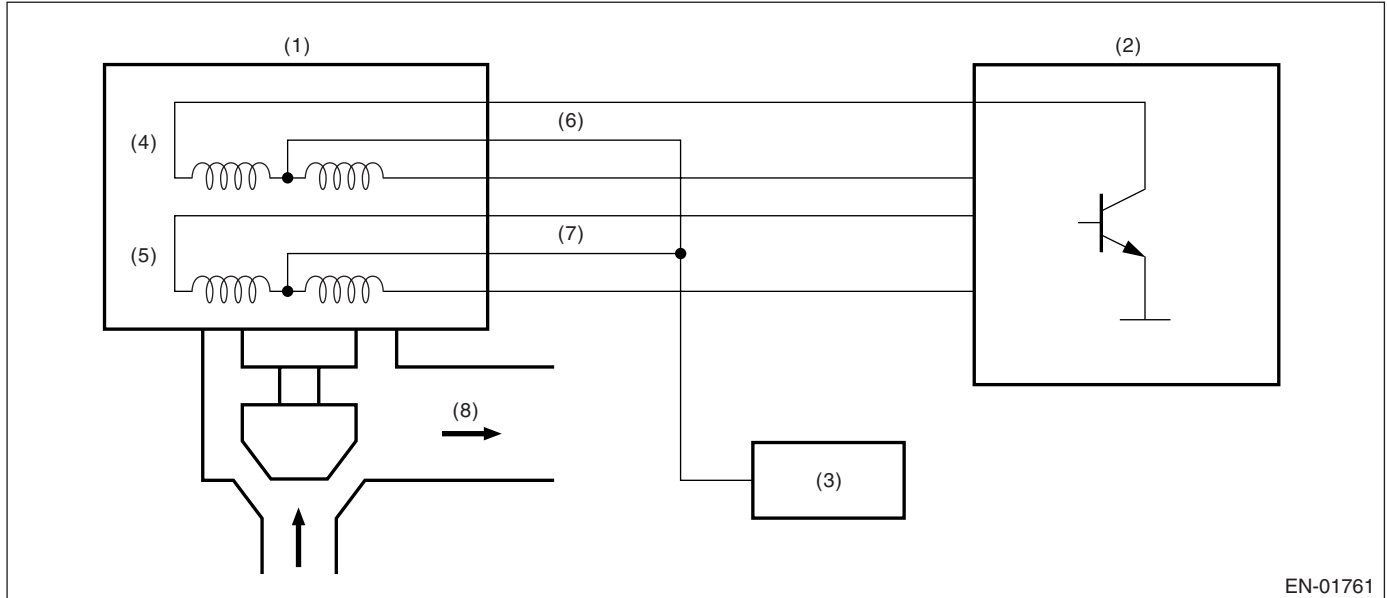

- |                                     |                   |
|-------------------------------------|-------------------|
| (1) Idle air control solenoid valve | (5) B phase       |
| (2) Engine control module (ECM)     | (6) A phase power |
| (3) Ignition relay                  | (7) B phase power |
| (4) A phase                         | (8) Intake air    |

#### 3. ENABLE CONDITION

Secondary Parameters	Enable Conditions
Starter switch	OFF
Battery voltage	> 10.9 V

#### 4. GENERAL DRIVING CYCLE

Perform the diagnosis continuously when starter switch is OFF.

#### 5. DIAGNOSTIC METHOD

##### • Abnormality Judgment

Judge NG when the cumulative time until completing the malfunction criteria below becomes more than time needed for diagnosis.

##### Judgment Value

Malfunction Criteria	Threshold Value
Terminal voltage level when ECM outputs ON signal	High level

**Time Needed for Diagnosis:** 0.5 seconds

**Malfunction Indicator Light Illumination:** Illuminates as soon as malfunction occurs.

# DIAGNOSTIC TROUBLE CODE (DTC) DETECTING CRITERIA

GENERAL DESCRIPTION

## • Normality Judgment

Judge OK and clear the NG when the malfunction criteria below are completed.

### Judgment Value

Malfunction Criteria	Threshold Value
Terminal voltage level when ECM outputs ON signal	Low level

## 6. DTC CLEAR CONDITION

- When the OK idling cycle is completed 40 times in a row
- When "Clear Memory" was performed

## 7. MALFUNCTION INDICATOR LIGHT CLEAR CONDITION

- When the OK driving cycle was completed 3 times in a row
- When "Clear Memory" was performed

## 8. FAIL SAFE

- Cut the fuel of all cylinders, #1 cylinder or #1, #2 cylinder according to throttle position, engine speed, vehicle speed.
- ISC closed loop compensation value becomes zero. [ISCCL = 0 (1/min)]

## 9. ECM OPERATION AT DTC

Memorize the freeze frame data. (For test mode \$02)

# DIAGNOSTIC TROUBLE CODE (DTC) DETECTING CRITERIA

## GENERAL DESCRIPTION

---

### DR:DTC P1518 — STARTER SWITCH CIRCUIT LOW INPUT —

#### 1. OUTLINE OF DIAGNOSIS

- Detect the open/short circuit of starter switch.
- Judge OFF NG when the starter signal remains to be ON regard less of both vehicle speed and engine speed become high.

#### 2. ENABLE CONDITION

Secondary Parameters	Enable Conditions
Engine	Run

#### 3. GENERAL DRIVING CYCLE

Perform the diagnosis continuously after starting engine.

#### 4. DIAGNOSTIC METHOD

Judge NG when the continuous time of completing all the conditions below becomes more than 10 seconds. Judge OK and clear NG when the start switch is turned ON to OFF.

##### Judgment value

Malfunction Criteria	Threshold Value
Engine speed	≥ 1500
Vehicle speed	≥ 30 km/h (19 MPH)
Starter "ON" signal	Not detected

##### Time Needed for Diagnosis

OFF side                      10 seconds

**Malfunction Indicator Light Illumination:** Illuminates when malfunction occurs in 2 continuous driving cycles.

#### 5. DTC CLEAR CONDITION

- When the OK idling cycle is completed 40 times in a row
- When "Clear Memory" was performed

#### 6. MALFUNCTION INDICATOR LIGHT CLEAR CONDITION

- When the OK driving cycle was completed 3 times in a row
- When "Clear Memory" was performed

#### 7. FAIL SAFE

None

#### 8. ECM OPERATION AT DTC

Memorize the freeze frame data. (For test mode \$02)

# DIAGNOSTIC TROUBLE CODE (DTC) DETECTING CRITERIA

GENERAL DESCRIPTION

## DS:DTC P1560 — BACK-UP VOLTAGE CIRCUIT MALFUNCTION —

### 1. OUTLINE OF DIAGNOSIS

- Detect the open/short circuit of back-up power supply circuit.
- Judge NG when the back-up power supply does not come to ECM regardless of the battery voltage coming.

### 2. ENABLE CONDITION

Secondary Parameters	Enable Conditions
Self-diagnosis timer after starting the engine	$\geq 5$ seconds
Battery voltage MVB	$\geq 9.2$ V

### 3. GENERAL DRIVING CYCLE

Always perform the diagnosis continuously in 5 seconds after starting the engine.

### 4. DIAGNOSTIC METHOD

Judge NG and clear the NG when the cumulative time until completing the malfunction criteria below becomes more than the time (5 seconds) needed for diagnosis.

#### Judgment Value

Malfunction Criteria	Threshold Value
Battery back-up voltage	Battery voltage $\times 0.7$

**Time Needed for Diagnosis:** 5 seconds

**Malfunction indicator Light Illumination:** Illuminates as soon as malfunction occurs.

### 5. DTC CLEAR CONDITION

- When the OK idling cycle is completed 40 times in a row
- When "Clear Memory" was performed

### 6. MALFUNCTION INDICATOR LIGHT CLEAR CONDITION

- When the OK driving cycle is completed 3 times in a row
- When "Clear Memory" was performed

### 7. FAIL SAFE

None

### 8. ECM OPERATION AT DTC SETTING

Memorize the freeze frame data. (For test mode \$02)

# DIAGNOSTIC TROUBLE CODE (DTC) DETECTING CRITERIA

## GENERAL DESCRIPTION

### DT:DTC P1698 — ENGINE TORQUE CONTROL CUT SIGNAL CIRCUIT MALFUNCTION (LOW INPUT) —

#### 1. OUTLINE OF DIAGNOSIS

- Detect the open/short circuit of AT cooperative signal line.
- Judge NG when ECM output level is different from actual terminal level.

#### 2. ENABLE CONDITION

Secondary Parameters	Enable Conditions
Engine speed	≥ 500 rpm
Battery voltage	≥ 8.0 V
After engine starting	1 second or more

#### 3. GENERAL DRIVING CYCLE

Perform the diagnosis continuously after starting the engine.

#### 4. DIAGNOSTIC METHOD

##### • Abnormality Judgment

Judge NG when the cumulative time until completing the malfunction criteria below becomes more than the time (0.5 seconds) needed for diagnosis.

##### Judgment Value

Malfunction Criteria	Threshold Value
Terminal voltage when ECM outputs OFF signal	Low

**Time Needed for Diagnosis:** 0.5 seconds

**Malfunction Indicator Light Illumination:** Illuminates when malfunction occurs in 2 continuous driving cycles.

##### • Normality Judgment

Judge OK and clear the NG when the malfunction criteria below are completed.

##### Judgment Value

Malfunction Criteria	Threshold Value
Terminal voltage when ECM outputs OFF signal	High

#### 5. DTC CLEAR CONDITION

- When the OK idling cycle is completed 40 times in a row
- When “Clear Memory” was performed

#### 6. MALFUNCTION INDICATOR LIGHT CLEAR CONDITION

- When the OK driving cycle was completed 3 times in a row
- When “Clear Memory” was performed

#### 7. FAIL SAFE

None

#### 8. ECM OPERATION AT DTC

Memorize the freeze frame data. (For test mode \$02)



# DIAGNOSTIC TROUBLE CODE (DTC) DETECTING CRITERIA

GENERAL DESCRIPTION

## DU:DTC P1699 — ENGINE TORQUE CONTROL CUT SIGNAL CIRCUIT MALFUNCTION (HIGH INPUT) —

### 1. OUTLINE OF DIAGNOSIS

- Detect the open/short circuit of AT cooperative signal line.
- Judge NG when ECM output level is different from actual terminal level.

### 2. ENABLE CONDITION

Secondary Parameters	Enable Conditions
Engine speed	≥ 500 rpm
Battery voltage	≥ 8.0 V
After engine starting	1 second or more

### 3. GENERAL DRIVING CYCLE

Perform the diagnosis continuously after starting the engine.

### 4. DIAGNOSTIC METHOD

#### • Abnormality Judgment

Judge NG when the cumulative time until completing the malfunction criteria below becomes more than the time (0.5 seconds) needed for diagnosis.

#### Judgment Value

Malfunction Criteria	Threshold Value
Terminal voltage when ECM outputs ON signal	High

**Time Needed for Diagnosis:** 0.5 seconds

**Malfunction Indicator Light Illumination:** Illuminates when malfunction occurs in 2 continuous driving cycles.

#### • Normality Judgment

Judge OK and clear the NG when the malfunction criteria below are completed.

#### Judgment Value

Malfunction Criteria	Threshold Value
Terminal voltage when ECM outputs ON signal	Low

### 5. DTC CLEAR CONDITION

- When the OK idling cycle is completed 40 times in a row
- When “Clear Memory” was performed

### 6. MALFUNCTION INDICATOR LIGHT CLEAR CONDITION

- When the OK driving cycle was completed 3 times in a row
- When “Clear Memory” was performed

### 7. FAIL SAFE

None

### 8. ECM OPERATION AT DTC

Memorize the freeze frame data. (For test mode \$02)

# DIAGNOSTIC TROUBLE CODE (DTC) DETECTING CRITERIA

## GENERAL DESCRIPTION

### DV:DTC P1700 — THROTTLE POSITION SENSOR CIRCUIT MALFUNCTION FOR AT —

#### 1. OUTLINE OF DIAGNOSIS

Judge NG when the voltage from throttle sensor is out of specified value.

#### 2. COMPONENT DESCRIPTION

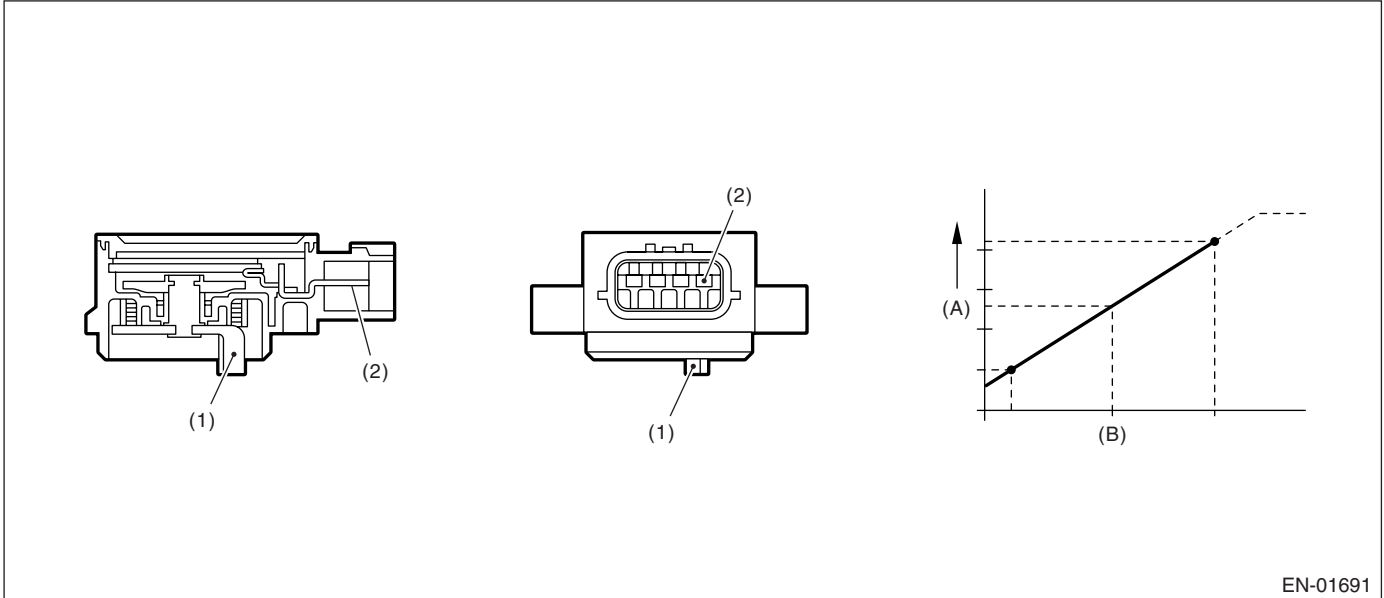

- (1) Lever
- (2) Terminal

- (A) Output voltage
- (B) Throttle valve angle

EN-01691

#### 3. ENABLE CONDITION

Secondary Parameters	Enable Conditions
None	

#### 4. GENERAL DRIVING CYCLE

Always perform the diagnosis continuously.

#### 5. DIAGNOSTIC METHOD

##### Judgment Value

Malfunction Criteria	Threshold Value
Output voltage	$\leq 0.1$ or $\geq 4.6$ V

**Time Needed for Diagnosis:** 63.75 seconds

**Malfunction Indicator Light Illumination:** Illuminates when malfunction occurs in 2 continuous driving cycles.

#### 6. DTC CLEAR CONDITION

- When the OK idling cycle was completed 40 times in a row
- When "Clear Memory" was performed

#### 7. MALFUNCTION INDICATOR LIGHT CLEAR CONDITION

- When the OK driving cycle was completed 3 times in a row
- When "Clear Memory" was performed

#### 8. FAIL SAFE

Make the throttle angle to 3/8 open, and the line pressure and 2-4B pressure to maximum.

# DIAGNOSTIC TROUBLE CODE (DTC) DETECTING CRITERIA

GENERAL DESCRIPTION

---

## 9. ECM OPERATION AT DTC SETTING

Memorize the freeze frame data. (For test mode \$02)

# DIAGNOSTIC TROUBLE CODE (DTC) DETECTING CRITERIA

## GENERAL DESCRIPTION

---

### DW:DTC P1711 — ENGINE TORQUE CONTROL SIGNAL #1 CIRCUIT MAL-FUNCTION —

#### 1. OUTLINE OF DIAGNOSIS

Judge NG when detecting the difference 250 times in a row by comparing the CPU output with signal line output every 10 milliseconds.

#### 2. ENABLE CONDITION

Secondary Parameters	Enable Conditions
None	

#### 3. GENERAL DRIVING CYCLE

Always perform the diagnosis continuously.

#### 4. DIAGNOSTIC METHOD

##### Judgment Value

Malfunction Criteria	Threshold Value
Collector voltage of transistor (Vc) at "ON" signal from TCM	High level
Collector voltage of transistor (Vc) at "OFF" signal from ECM	Low level

**Time Needed for Diagnosis:** 2.5 seconds

**Malfunction Indicator Light Illumination:** Illuminates when malfunction occurs in 2 continuous driving cycles.

#### 5. DTC CLEAR CONDITION

- When the OK idling cycle was completed 40 times in a row
- When "Clear Memory" was performed

#### 6. MALFUNCTION INDICATOR LIGHT CLEAR CONDITION

- When the OK driving cycle was completed 3 times in a row
- When "Clear Memory" was performed

#### 7. FAIL SAFE

None

#### 8. ECM OPERATION AT DTC SETTING

Memorize the freeze frame data. (For test mode \$02)

# DIAGNOSTIC TROUBLE CODE (DTC) DETECTING CRITERIA

GENERAL DESCRIPTION

## DX:DTC P1712 — ENGINE TORQUE CONTROL SIGNAL #2 CIRCUIT MALFUNCTION —

### 1. OUTLINE OF DIAGNOSIS

Judge NG when detecting the difference 250 times in a row by comparing the CPU output with signal line output every 10 milliseconds.

### 2. ENABLE CONDITION

Secondary Parameters	Enable Conditions
None	

### 3. GENERAL DRIVING CYCLE

Always perform the diagnosis continuously.

### 4. DIAGNOSTIC METHOD

#### Judgment Value

Malfunction Criteria	Threshold Value
Vc at "ON" signal from ECM	High
Vc at "OFF" signal from ECM	Low

**Time Needed for Diagnosis:** 2.5 seconds

**Malfunction Indicator Light Illumination:** Illuminates when malfunction occurs in 2 continuous driving cycles.

### 5. DTC CLEAR CONDITION

- When the OK idling cycle was completed 40 times in a row
- When "Clear Memory" was performed

### 6. MALFUNCTION INDICATOR LIGHT CLEAR CONDITION

- When the OK driving cycle was completed 3 times in a row
- When "Clear Memory" was performed

### 7. FAIL SAFE

None

### 8. ECM OPERATION AT DTC SETTING

Memorize the freeze frame data. (For test mode \$02)

# DIAGNOSTIC TROUBLE CODE (DTC) DETECTING CRITERIA

## GENERAL DESCRIPTION

### DY:DTC P2096 — POST CATALYST FUEL TRIM SYSTEM TOO LEAN BANK 1 —

#### 1. OUTLINE OF DIAGNOSIS

Detect the malfunction of fuel system from the amount of sub feedback control.

Judge NG when the rear oxygen sensor output does not approach to the slice level (target voltage) with the control amount sticks to rich or lean side while operating the sub feedback control.

#### 2. COMPONENT DESCRIPTION

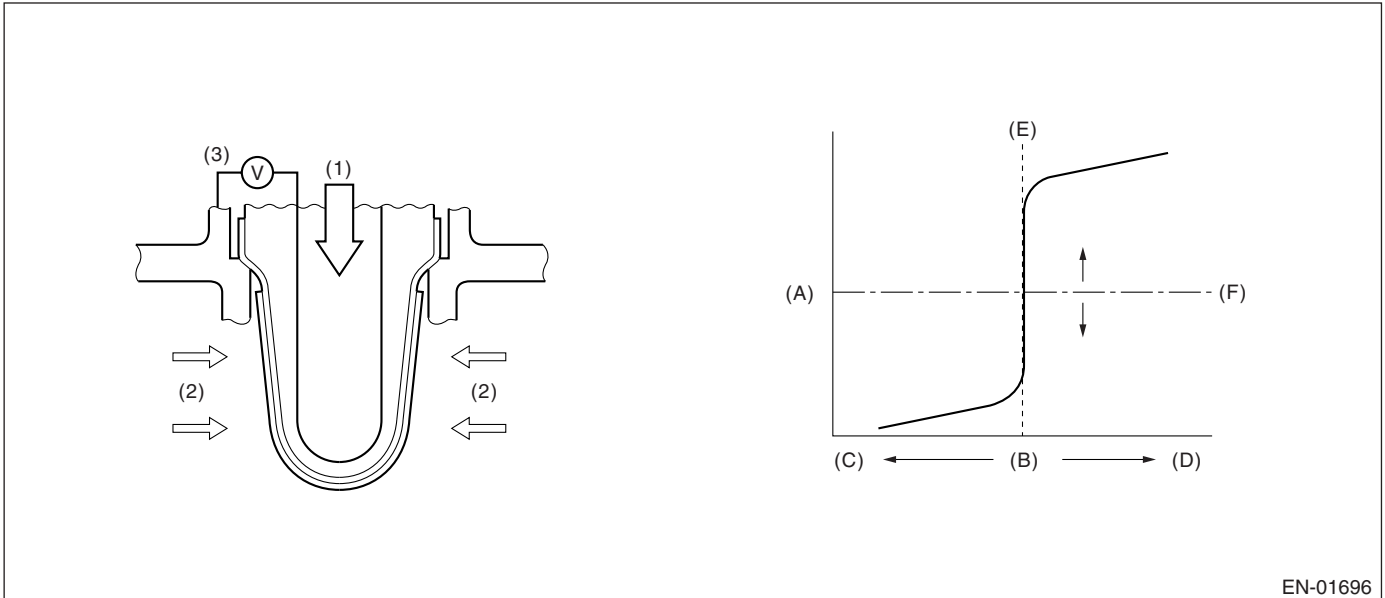

- (1) Atmosphere
- (2) Exhaust gas
- (3) Electromotive force

- (A) Electromotive force
- (B) Air fuel ratio
- (C) Lean
- (D) Rich
- (E) Theoretical air fuel ratio
- (F) Comparative voltage

#### 3. ENABLE CONDITION

Secondary Parameters	Enable Conditions
Fuel system monitoring with primary oxygen sensor	In operation
Target lambda with primary oxygen sensor	1.0
Closed loop control with secondary oxygen sensor	In operation
Amount of intake air	≥ 20 kg/h
Feed back control with secondary oxygen sensor	Reached to the limit value

#### 4. GENERAL DRIVING CYCLE

Perform the diagnosis continuously at a constant 20 km/h (12 MPH) or more.

# DIAGNOSTIC TROUBLE CODE (DTC) DETECTING CRITERIA

GENERAL DESCRIPTION

## 5. DIAGNOSTIC METHOD

### • Abnormality Judgment

Calculate the continuous time from the sticking of sub feedback control amount to rich or lean side and cumulative deviation (sumdelo2) of rear oxygen sensor voltage and slice level (target voltage).

Judge NG when the malfunction criteria below are completed after 300 seconds have passed continuously.

### Judgment Value

Malfunction Criteria	Threshold Value
$\text{sumdelo2} = \text{sumdelo2} + (\text{rvo2} - \text{rsl})$ where: rvo2 = sensing voltage of secondary oxygen sensor rsl = target voltage of secondary oxygen sensor	> -16740 V

**Time Needed for Diagnosis:** 300 seconds

**Malfunction Indicator Light Illumination:** Illuminates when malfunction occurs in 2 continuous driving cycles.

### • Normality Judgment

Judge OK and clear the NG when the rear oxygen output is reversed, and during 4 seconds after that, the sub feedback control amount does not stick to rich or lean sides.

## 6. DTC CLEAR CONDITION

- When the OK idling cycle was completed 40 times in a row
- When "Clear Memory" was performed

## 7. MALFUNCTION INDICATOR LIGHT CLEAR CONDITION

- When the OK driving cycle was completed 3 times in a row
- When "Clear Memory" was performed

## 8. FAIL SAFE

None

## 9. ECM OPERATION AT DTC SETTING

Memorize the freeze frame data. (For test mode \$02)

# DIAGNOSTIC TROUBLE CODE (DTC) DETECTING CRITERIA

## GENERAL DESCRIPTION

### DZ:DTC P2097 — POST CATALYST FUEL TRIM SYSTEM TOO RICH BANK 1 —

#### 1. OUTLINE OF DIAGNOSIS

Detect the malfunction of fuel system from the amount of sub feedback control.

Judge NG when the rear oxygen sensor output does not approach to the slice level (target voltage) with the control amount sticks to rich or lean side while operating the sub feedback control.

#### 2. COMPONENT DESCRIPTION

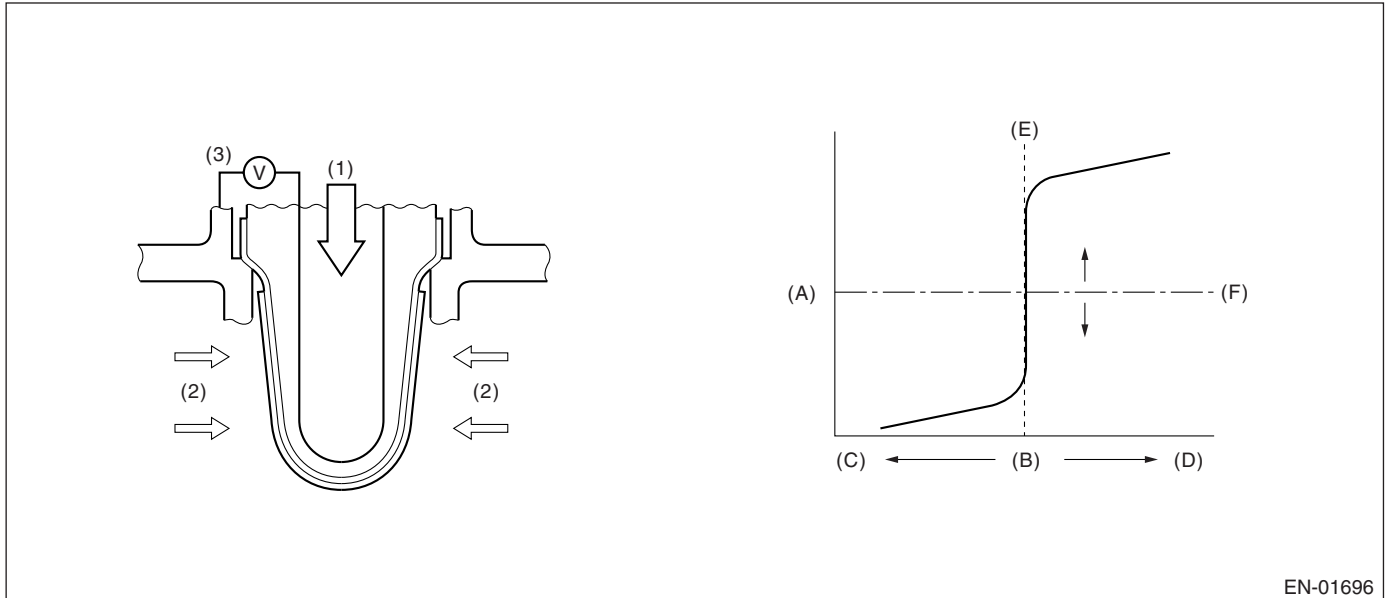

- (1) Atmosphere
- (2) Exhaust gas
- (3) Electromotive force

- (A) Electromotive force
- (B) Air fuel ratio
- (C) Lean
- (D) Rich
- (E) Theoretical air fuel ratio
- (F) Comparative voltage

#### 3. ENABLE CONDITION

Secondary Parameters	Enable Conditions
Fuel system monitoring with primary oxygen sensor	In operation
Target lambda with primary oxygen sensor	1.0
Closed loop control with secondary oxygen sensor	In operation
Amount of intake air	$\geq 20$ kg/h
Feed back control with secondary oxygen sensor	Reached to the limit value

#### 4. GENERAL DRIVING CYCLE

Perform the diagnosis continuously at a constant 20 km/h (12 MPH) or more.



# DIAGNOSTIC TROUBLE CODE (DTC) DETECTING CRITERIA

GENERAL DESCRIPTION

## 5. DIAGNOSTIC METHOD

### • Abnormality Judgment

Calculate the continuous time from the sticking of sub feedback control amount to rich or lean side and cumulative deviation (sumdelo2) of rear oxygen sensor voltage and slice level (target voltage).

Judge NG when the malfunction criteria below are completed after 300 seconds have passed continuously.

### Judgment Value

Malfunction Criteria	Threshold Value
$\text{sumdelo2} = \text{sumdelo2} + (\text{rvo2} - \text{rsl})$ where: rvo2 = sensing voltage of secondary oxygen sensor rsl = target voltage of secondary oxygen sensor	> 6750 V

**Time Needed for Diagnosis:** 300 seconds

**Malfunction Indicator Light Illumination:** Illuminates when malfunction occurs in 2 continuous driving cycles.

### • Normality Judgment

Judge OK and clear the NG when the rear oxygen output is reversed, and during 4 seconds after that, the sub feedback control amount does not stick to rich or lean sides.

## 6. DTC CLEAR CONDITION

- When the OK idling cycle was completed 40 times in a row
- When "Clear Memory" was performed

## 7. MALFUNCTION INDICATOR LIGHT CLEAR CONDITION

- When the OK driving cycle was completed 3 times in a row
- When "Clear Memory" was performed

## 8. FAIL SAFE

None

## 9. ECM OPERATION AT DTC SETTING

Memorize the freeze frame data. (For test mode \$02)

# DIAGNOSTIC TROUBLE CODE (DTC) DETECTING CRITERIA

GENERAL DESCRIPTION

---