

14. Timing Belt Cover

A: REMOVAL

- 1) Remove the V-belt. <Ref. to ME(H4SO)-42, REMOVAL, V-belt.>
- 2) Remove the crank pulley. <Ref. to ME(H4SO)-44, REMOVAL, Crank Pulley.>
- 3) Remove the timing belt cover (LH).
- 4) Remove the front timing belt cover.

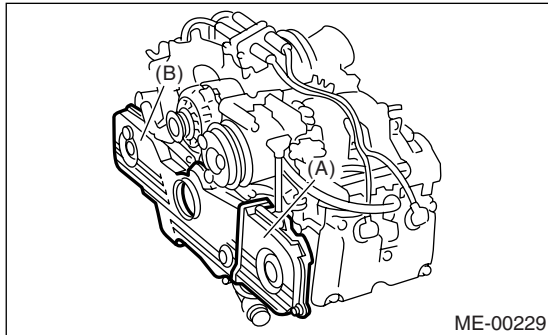

- (A) Timing belt cover (LH)
 (B) Front timing belt cover

B: INSTALLATION

- 1) Install the front timing belt cover.

Tightening torque:

5 N·m (0.5 kgf·m, 3.6 ft·lb)

- 2) Install the timing belt cover (LH).

Tightening torque:

5 N·m (0.5 kgf·m, 3.6 ft·lb)

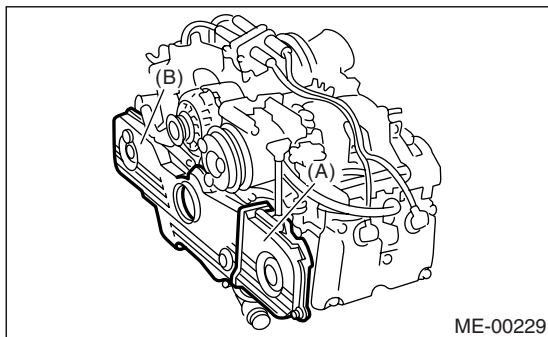

- (A) Timing belt cover (LH)
 (B) Front timing belt cover

- 3) Install the crank pulley. <Ref. to ME(H4SO)-44, INSTALLATION, Crank Pulley.>
- 4) Install the V-belt. <Ref. to ME(H4SO)-42, INSTALLATION, V-belt.>

C: INSPECTION

Make sure the cover is not damaged.