

8. Valve Clearance

A: INSPECTION

NOTE:

Inspection and adjustment of the valve clearance should be performed while engine is cold.

- 1) Set the vehicle on a lift.
- 2) Lift-up the vehicle.
- 3) Remove the under cover.
- 4) Lower the vehicle.
- 5) Disconnect the ground cable from battery.

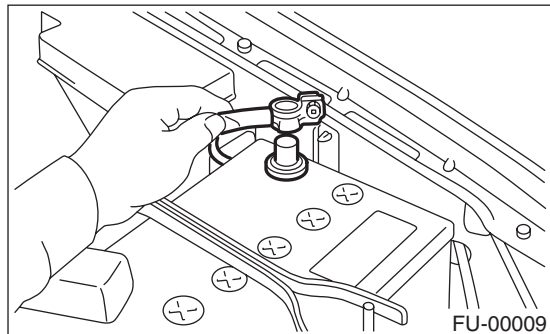

- 6) Remove the timing belt cover (LH).

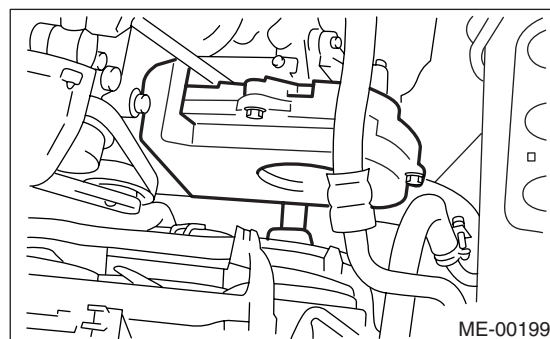

- 7) When inspecting the #1 and #3 cylinders;
 - (1) Disconnect the spark plug cords from spark plugs RH side. <Ref. to IG(H4SO)-5, RH SIDE, REMOVAL, Spark Plug.>
 - (2) Disconnect the PCV hose from rocker cover (RH).
 - (3) Remove the bolts, and then remove the rocker cover (RH).
- 8) When inspecting the #2 and #4 cylinders;
 - (1) Disconnect the spark plug cords from spark plugs (LH Side). <Ref. to IG(H4SO)-5, LH SIDE, REMOVAL, Spark Plug.>
 - (2) Disconnect the PCV hose from rocker cover (LH).
 - (3) Remove the bolts, and then remove the rocker cover (LH).

- 9) Set the #1 cylinder piston to top dead center of compression stroke by rotating crank pulley clockwise using ST.

ST 499977100 CRANK PULLEY WRENCH

NOTE:

When arrow mark (A) on the cam sprocket (LH) comes exactly to the top, #1 cylinder piston is brought to the top dead center of compression stroke.

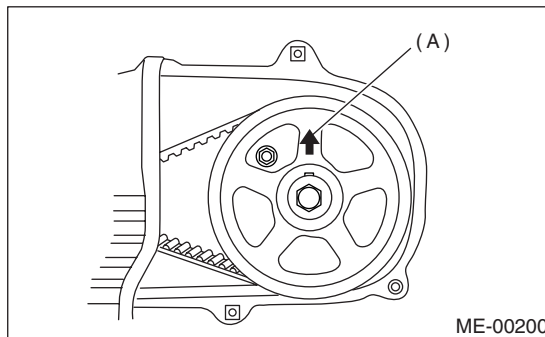

- 10) Measure the #1 cylinder valve clearance by using thickness gauge.

CAUTION:

- Insert the thickness gauge (A) in as horizontal a direction as possible with respect to the valve stem end face.
- Measure the exhaust valve clearances while lifting-up the vehicle.

Valve clearance

Intake:

0.20±0.02 mm (0.0079±0.0008 in)

Exhaust:

0.25±0.02 mm (0.0098±0.0008 in)

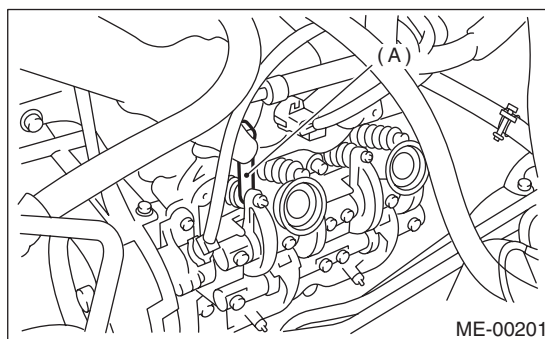

- 11) If necessary, adjust the valve clearance. <Ref. to ME(H4SO)-32, ADJUSTMENT, Valve Clearance.>

VALVE CLEARANCE

MECHANICAL

12) Similar to measurement procedures used for #1 cylinder, measure the cylinder valve clearances in the following sequence: #3, #2 and #4 cylinder.

NOTE:

- Be sure to set the cylinder pistons to their respective top dead centers on compression stroke before measuring valve clearances.
- To set each cylinder piston to its top dead center on compression stroke in the following sequence: #3, #2 and #4 cylinder, turn the crank pulley clockwise by every 180° at starting with #1 cylinder piston being on top dead center on compression stroke.

13) After inspection, install the related parts in the reverse order of removal.

B: ADJUSTMENT

CAUTION:

Adjustment of the valve clearance should be performed while engine is cold.

1) Set the #1 cylinder piston to top dead center of compression stroke by rotating crank pulley clockwise using ST.

ST 499977100 CRANK PULLEY WRENCH

NOTE:

When arrow mark (A) on the cam sprocket (LH) comes exactly to the top, #1 cylinder piston is brought to the top dead center of compression stroke.

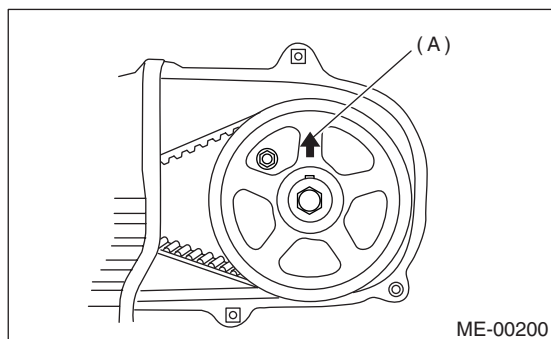

2) Adjust the #1 cylinder valve clearance.

- (1) Loosen the valve rocker nut and screw.
- (2) Place suitable thickness gauge.
- (3) While noting the valve clearance, tighten the valve rocker adjusting screw.
- (4) When specified valve clearance is obtained, tighten the valve rocker nut.

Tightening torque:

10 N·m (1.0 kgf·m, 7.2 ft·lb)

CAUTION:

- Insert the thickness gauge in as horizontal a direction as possible with respect to the valve stem end face.
- Adjust the exhaust valve clearances while lifting up the vehicle.

Valve clearance

Intake:

0.20±0.02 mm (0.0079±0.0008 in)

Exhaust:

0.25±0.02 mm (0.0098±0.0008 in)

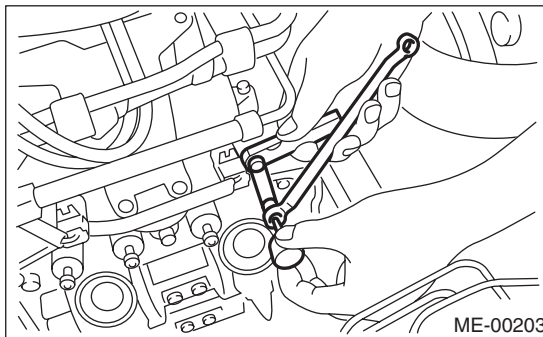

3) Ensure the valve clearances are within specifications.

4) Turn the crankshaft two complete rotations until #1 cylinder piston is again set to the top dead center on compression stroke.

5) Ensure the valve clearances are within specifications. If necessary, readjust the valve clearances.

6) Similar to adjustment procedures used for #1 cylinder, adjust the #3, #2 and #4 cylinder valve clearances.

NOTE:

- Be sure to set the cylinder pistons to their respective top dead centers on compression stroke before adjusting valve clearances.
- To set each cylinder piston to its top dead center on compression stroke in the following sequence: #3, #2 and #4 cylinder, turn the crank pulley clockwise by every 180° at starting with #1 cylinder piston being on top dead center on compression stroke.