

STARTER

STARTING/CHARGING SYSTEMS

2. Starter

A: REMOVAL

1) Disconnect the ground cable from battery.

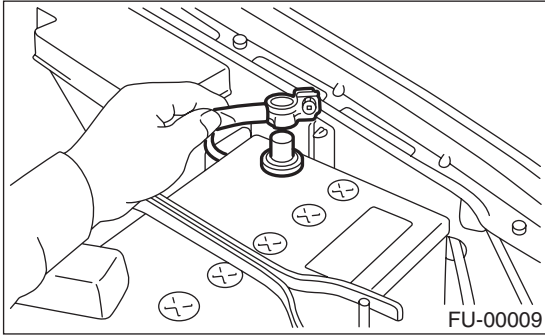

2) Remove the air cleaner case.
<Ref. to IN(H4SO)-6, REMOVAL, Air Cleaner Case.>

3) Remove the air cleaner case stay.

- MT model

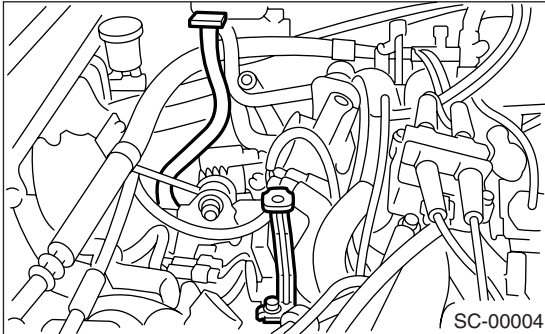

- AT model

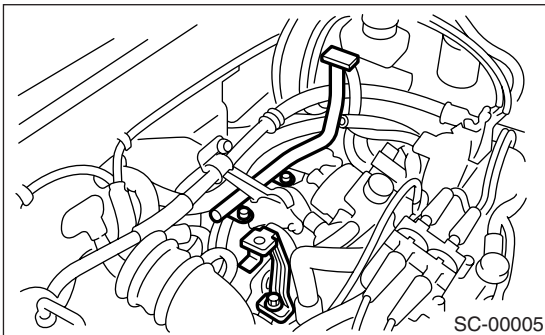

4) Disconnect the connector and terminal from starter.

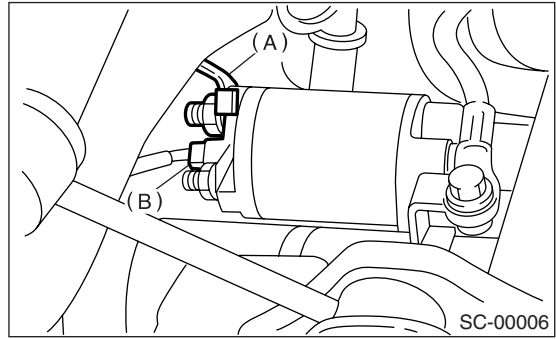

- (A) Terminal
- (B) Connector

5) Remove the starter from transmission.

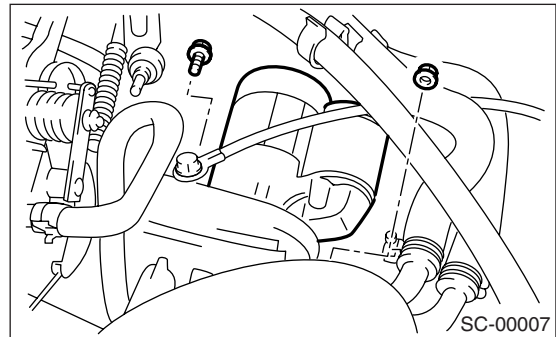

B: INSTALLATION

Install in the reverse order of removal.

Tightening torque:

50 N·m (5.1 kgf-m, 37 ft-lb)

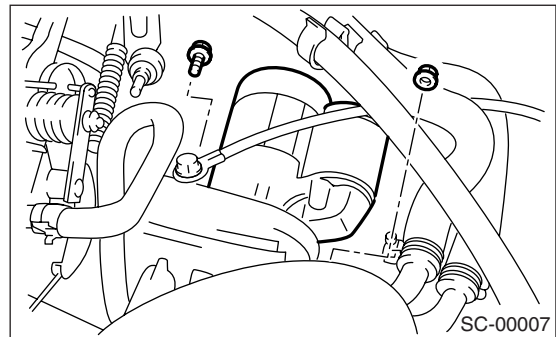

C: DISASSEMBLY

1. STARTER ASSEMBLY

1) Loosen the nut which holds terminal M of switch assembly, and then disconnect the connector.

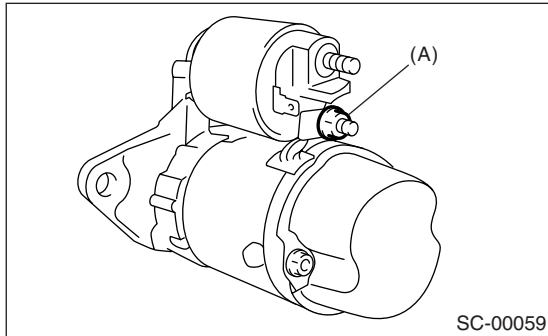

(A) Terminal M

2) Remove the bolts which hold switch assembly, and then remove the switch assembly, plunger and plunger spring from starter as a unit.

NOTE:

Be careful because the pinion gap adjustment washer may sometimes be used on the mounting surface of switch assembly.

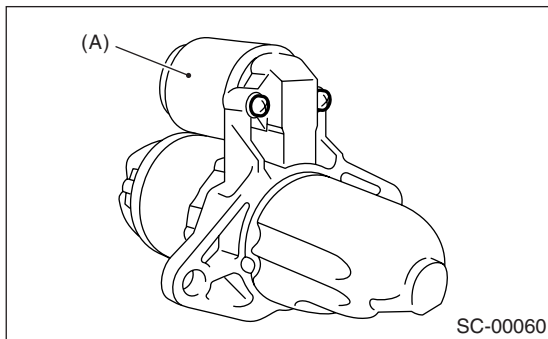

(A) Switch ASSY

3) Remove both the nuts, and then remove rear cover set.

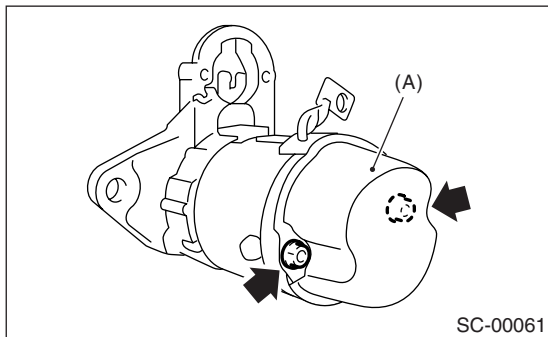

(A) Rear cover set

4) Remove both through-bolts and brush holder screws, and then detach the rear cover and brush holder assembly.

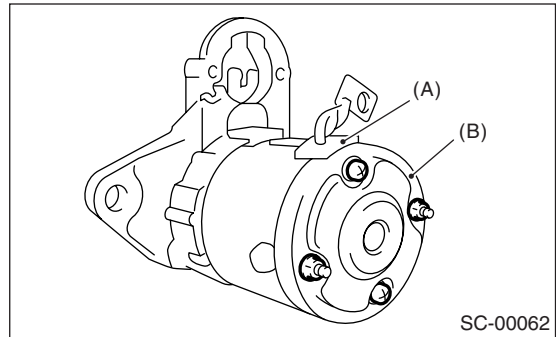

(A) Brush holder ASSY
(B) Rear cover

5) Remove the armature and yoke assembly from front bracket.

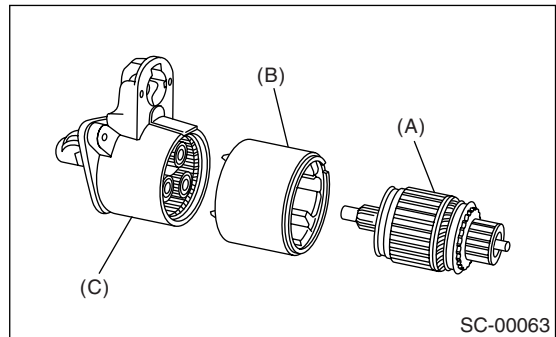

(A) Armature
(B) Yoke ASSY
(C) Front bracket

6) Remove the packing A, planetary gear and packing B.

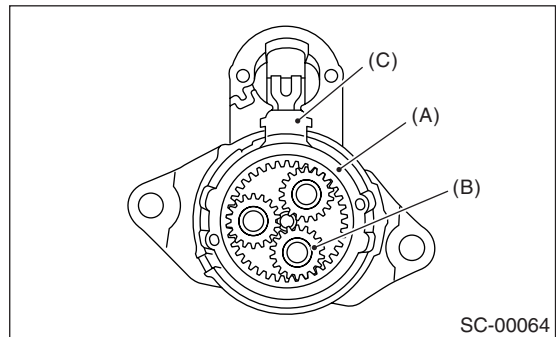

(A) Packing A
(B) Planetary gear
(C) Packing B

STARTER

STARTING/CHARGING SYSTEMS

7) Remove the plate.

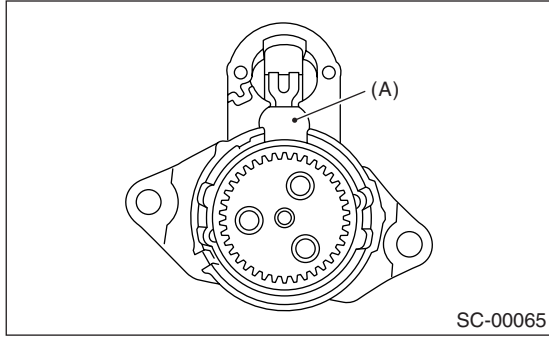

(A) Plate

8) Remove the shaft assembly and overrunning clutch from front bracket as a unit.

NOTE:

Check the following points before removal.

- Lever direction
- Position of internal gear assembly

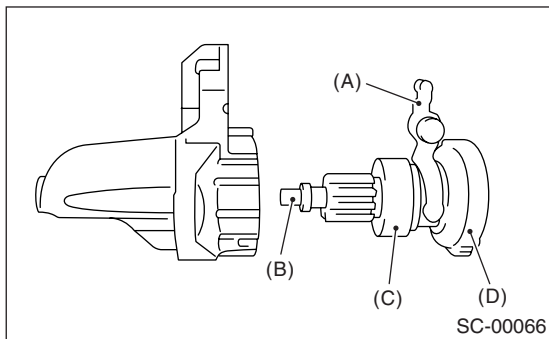

- (A) Lever
- (B) Shaft ASSY
- (C) Overrunning clutch
- (D) Internal gear ASSY

9) Remove the overrunning clutch from shaft assembly as follows:

(1) Remove the stopper from ring by lightly tapping the stopper with an appropriate tool (such as a fit socket wrench).

(2) Remove the ring, stopper and clutch from shaft.

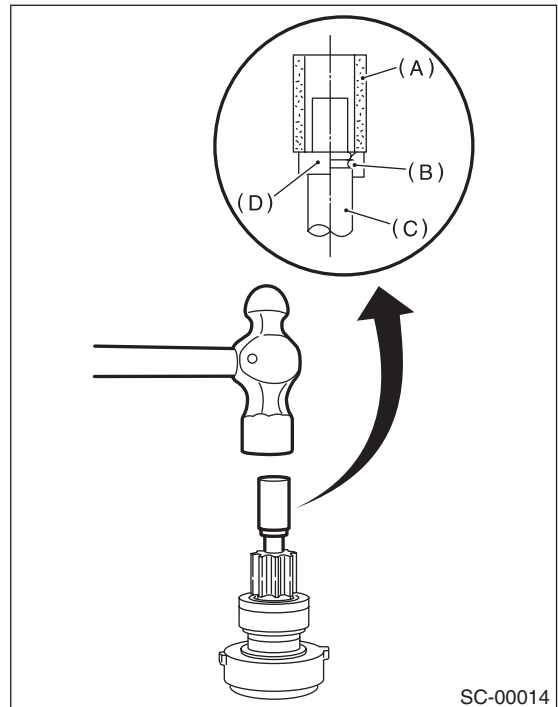

- (A) Socket wrench
- (B) Ring
- (C) Shaft
- (D) Stopper

D: ASSEMBLY

NOTE:

Apply grease to the following parts before assembly.

- Sleeve bearing
- Pinion shaft rotational portion
- Shaft spline portion
- Inside of reduction system
- Lever fulcrum/Clutch rotational portion

1) Install the overrunning clutch to shaft assembly.

2) Install the stopper to shaft assembly as follows.

- (1) Insert the ring into the shaft groove by lightly tapping it with an appropriate tool (such as a fit socket wrench).

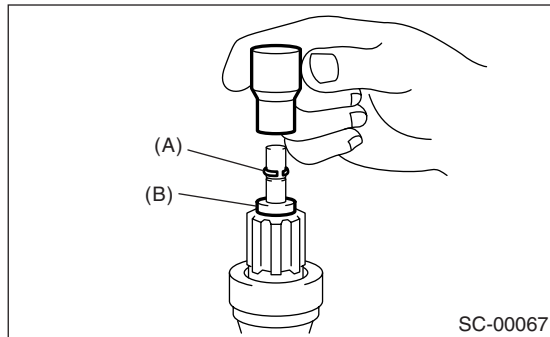

(2) Install the stopper to ring using a press.

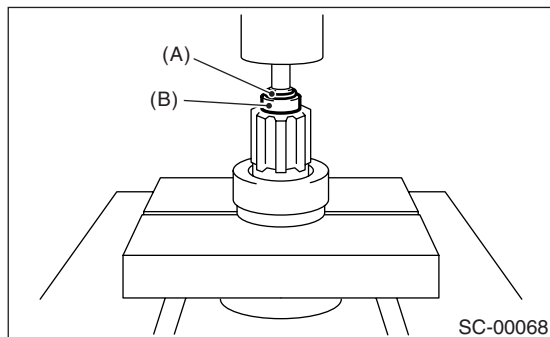

- (A) Ring
(B) Stopper

3) Install the shaft assembly to front bracket while taking care of the following points.

(1) Lever direction

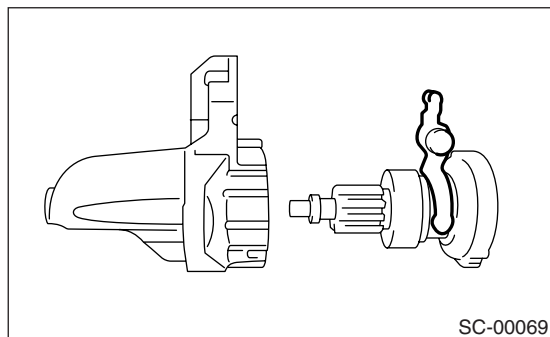

(2) Internal gear position

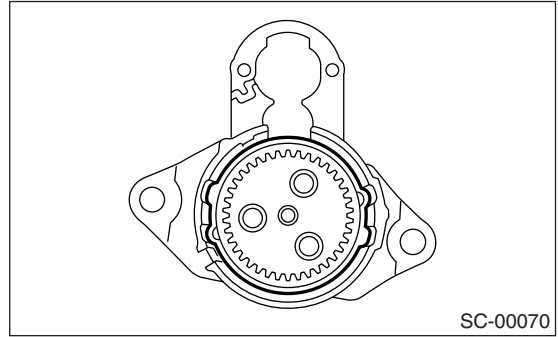

4) Install the plate.

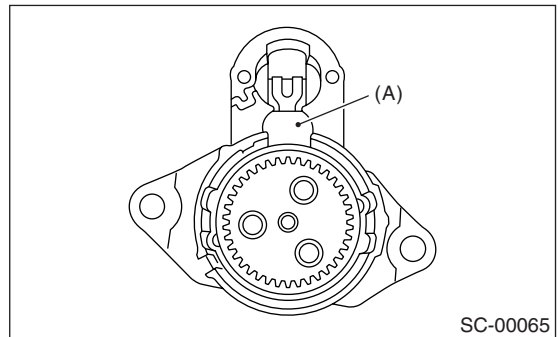

(A) Plate

5) Install the planetary gear.

6) Install packing A and B while taking care of installing positions.

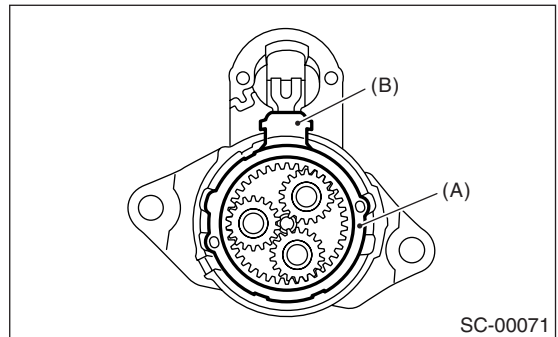

- (A) Packing A
(B) Packing B

7) Install the armature to yoke assembly.

STARTER

STARTING/CHARGING SYSTEMS

8) Install the yoke to front bracket matching front bracket to groove of yoke assembly.

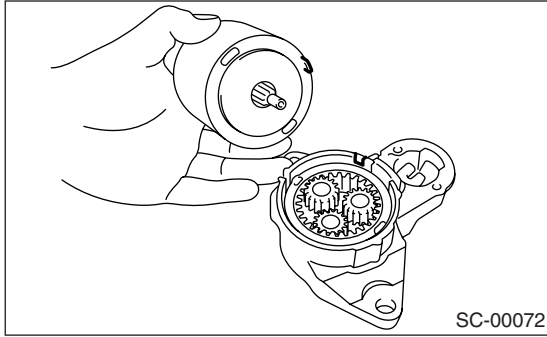

9) Install the brush holder to yoke assembly as follows.

(1) Press the brush down into brush holder, and then fix the brush in that position using an appropriate tool (such as a fit socket wrench).

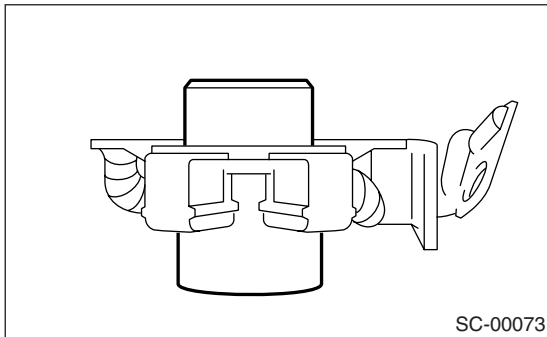

(2) Match the brush holder to groove of yoke assembly, and then slide the brush holder into yoke assembly to install.

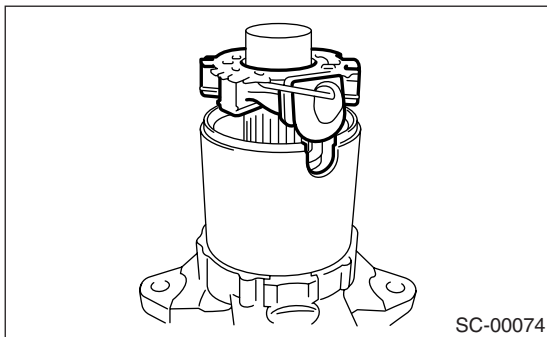

10) Install the rear cover matching its groove to brush holder assembly.

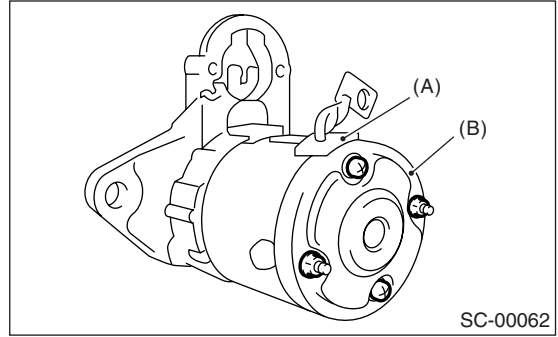

(A) Brush holder ASSY
(B) Rear cover

11) Install rear cover set.

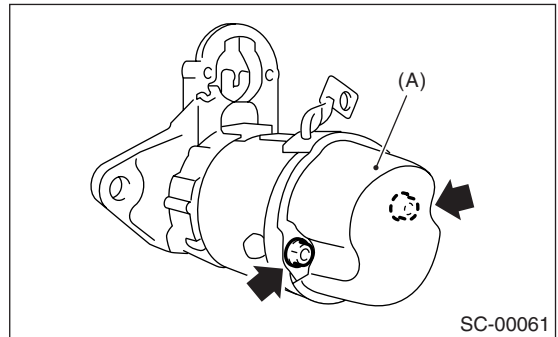

(A) Rear cover set

12) Install the switch assembly to front bracket as follows.

(1) Insert the plunger and plunger spring into switch assembly.

(2) Hook the plunger protrusion on lever edge to install plunger to front bracket.

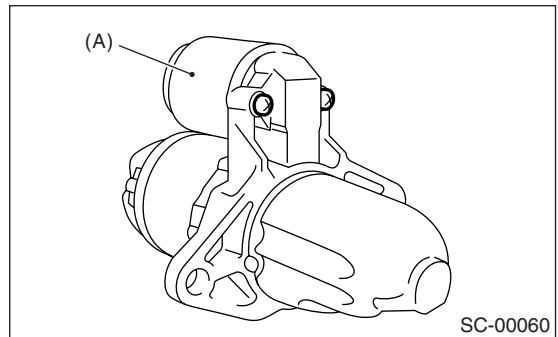

(A) Switch ASSY

13) Connect the connector to terminal M of switch assembly.

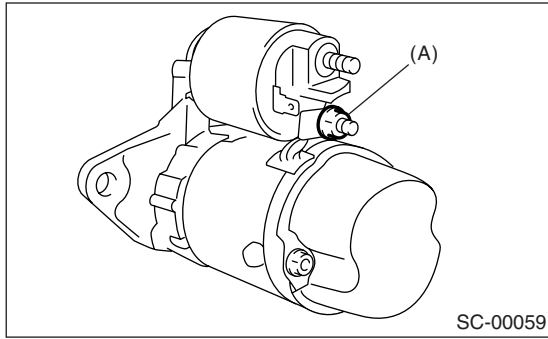

(A) Terminal M

Depth of segment mold:
0.5 mm (0.020 in)

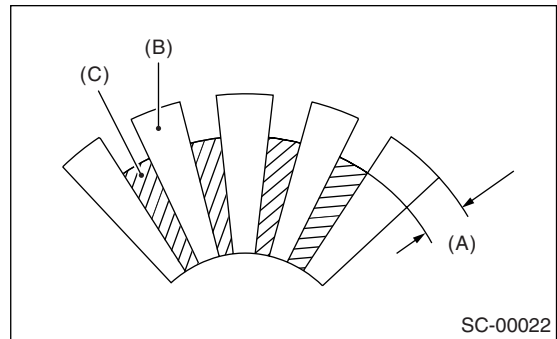

(A) Depth of segment mold
(B) Segment
(C) Mold

E: INSPECTION

1. ARMATURE

1) Check the commutator for any sign of burns or rough surfaces or stepped wear. If wear is of a minor nature, correct it by using sand paper.

2) Run-out test

Check the commutator run-out, and then replace if it exceeds the limit.

Commutator run-out:

Standard

0.05 mm (0.0020 in)

Service limit

Less than 0.10 mm (0.0039 in)

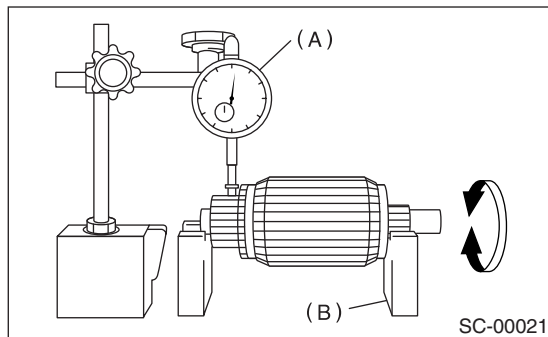

(A) Dial gauge
(B) V-block

3) Depth of segment mold
Check the depth of segment mold.

4) Armature short-circuit test

Check the armature for short-circuit by placing it on growler tester. Hold a iron sheet against the armature core while slowly rotating armature. A short-circuited armature will cause the iron sheet to vibrate and to be attracted to core. If the iron sheet is attracted or vibrates, the armature, which is short-circuited, must be replaced or repaired.

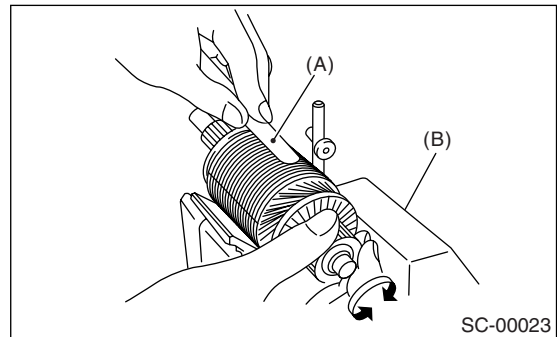

(A) Iron sheet
(B) Growler tester

5) Armature ground test

Using a circuit tester, touch one probe to the commutator segment and the other to shaft. There should be no continuity. If there is continuity, the armature is grounded.

Replace the armature if it is grounded.

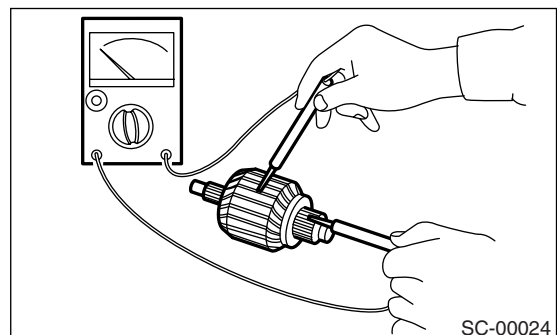

SC-00024

STARTER

STARTING/CHARGING SYSTEMS

2. YOKE

Make sure the pole is set in position.

3. OVERRUNNING CLUTCH

Inspect the teeth of pinion for wear and damage. Replace if it is damaged. Rotate the pinion in direction of rotation (counterclockwise). It should rotate smoothly. But in opposite direction, it should be locked.

CAUTION:

Do not clean the overrunning clutch with oil to prevent grease from flowing out.

4. BRUSH AND BRUSH HOLDER

1) Brush length

Measure the brush length, and then replace if it exceeds the service limit.

Replace if abnormal wear or cracks are noticed.

Brush length:

Standard

12.3 mm (0.484 in)

Service limit

7.0 mm (0.276 in)

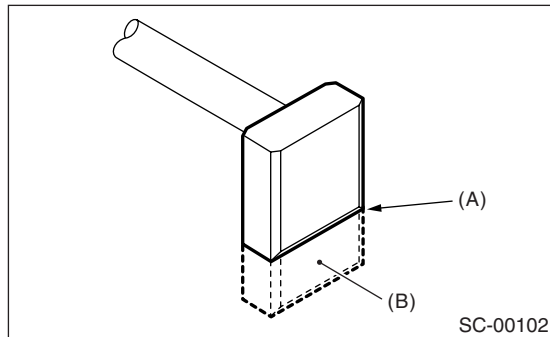

(A) Service limit line

(B) Brush

2) Brush movement

Be sure the brush moves smoothly inside brush holder.

3) Brush spring force

Measure the brush spring force with a spring scale. If it is less than the service limit, replace the brush holder.

Brush spring force:

Standard

15.9 — 19.5 N (1.62 — 1.99 kgf, 3.57 — 4.38 lb) (when new)

Service limit

2.5 N (0.25 kgf, 0.56 lb)

5. SWITCH ASSEMBLY

Be sure there is continuity between the terminals S and M, and between terminal S and ground. Use a circuit tester (set in “ohm”).

Also check to be sure there is no continuity between terminal M and B.

Terminal / Specified resistance:

S — M / Less than 1 Ω

S — Ground / Less than 1 Ω

M — B / More than 1 M Ω

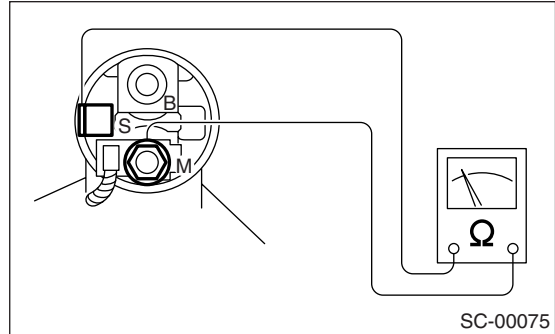

6. SWITCH ASSEMBLY OPERATION

1) Connect the terminal S of switch assembly to positive terminal of battery with a lead wire, and starter body to ground terminal of battery. The pinion should be forced endwise on shaft.

NOTE:

With the pinion forced endwise on shaft, starter motor can sometimes rotate because current flows, through pull-in coil, to motor. This is not a problem.

2) Disconnect the connector from terminal M, and then connect the positive terminal of battery and terminal M using a lead wire and ground terminal to starter body.

In this test set up, the pinion should return to its original position even when it is pulled out with a screwdriver.

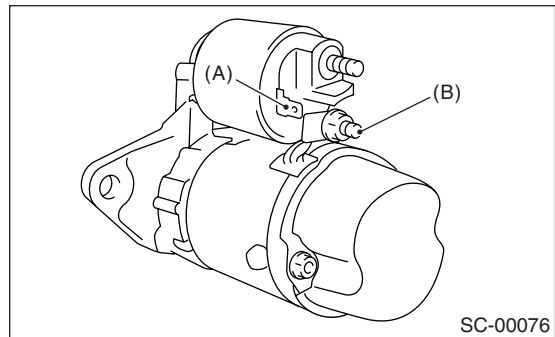

(A) Terminal S

(B) Terminal M

7. PINION GAP

1) Measure the pinion gap while the pinion is pulled out as shown in the figure.

Pinion gap:

0.5 — 2.0 mm (0.020 — 0.079 in)

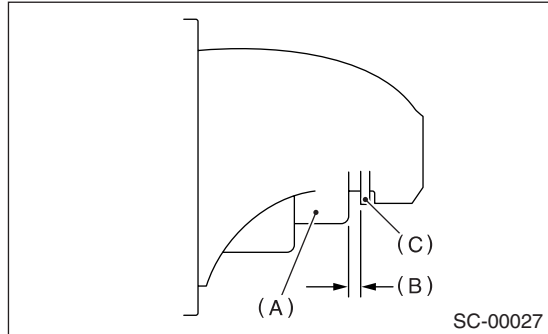

- (A) Pinion
- (B) Pinion gap
- (C) Stopper

If the motor is running with the pinion forced end-wise on shaft, disconnect the connector from terminal M of switch assembly, and then connect terminal M to ground terminal (-) of battery with a lead wire. Next, gently push the pinion back with your fingertips, and then measure the pinion gap.
 2) If the pinion gap is outside specified range, remove or add number of adjustment washers used on the mounting surface of switch assembly until correct pinion gap is obtained.

8. PERFORMANCE TEST

The starter should be submitted to performance tests whenever it has been overhauled, to assure its satisfactory performance when installed on the engine.

Three performance tests, no-load test, load test, and lock test, are presented here; however, if the load test and lock test cannot be performed, carry out at least the no-load test.

For these performance tests, use the circuit shown in figure.

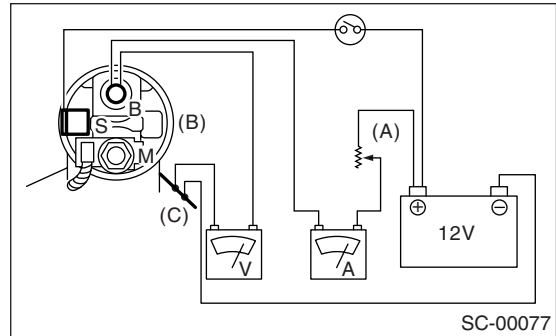

- (A) Variable resistance
- (B) Starter body
- (C) Magnetic switch

1) No-load test

With switch on, adjust the variable resistance to obtain 11 V, take the ammeter reading, and then measure the starter speed. Compare these values with the specifications.

No-load test (Standard):

Voltage / Current

MT model

MAX. 11 V / 95 A

AT model

MAX. 11 V / 90 A

Rotating speed

MT model

2,500 rpm or more

AT model

2,000 rpm or more

2) Load test

Apply the specified braking torque to starter. The condition is satisfactory if the current draw and starter speed are within the specifications.

Load test (Standard):

Voltage / Load

MT model

7.5 V / 8.84 N (0.90 kgf, 1.99 lb)

AT model

7.7 V / 16.7 N (1.70 kgf, 3.75 lb)

STARTER

STARTING/CHARGING SYSTEMS

Current / Speed

MT model

300 A / 870 rpm or more

AT model

400 A / 710 rpm or more

3) Lock test

With the starter stalled, or not rotating, measure the torque developed and current draw when the voltage is adjusted to the specified voltage.

Lock test (Standard):

Voltage / Current

MT model

4 V / 680 A or less

AT model

3.5 V / 960 A or less

Torque

MT model

17.0 N (1.73 kgf, 3.82 lb) or more

AT model

31.0 N (3.16 kgf, 6.97 lb) or more