

CONTROL VALVE BODY

AUTOMATIC TRANSMISSION

17. Control Valve Body

A: REMOVAL

1. NON-TURBO MODEL

- 1) Lift-up the vehicle.
- 2) Clean the transmission exterior.
- 3) Drain the ATF completely.

NOTE:

- Tighten the drain plug (ATF) after draining the ATF.
- Replace the gasket with a new one.

Tightening torque:

25 N·m (2.5 kgf-m, 18.1 ft-lb)

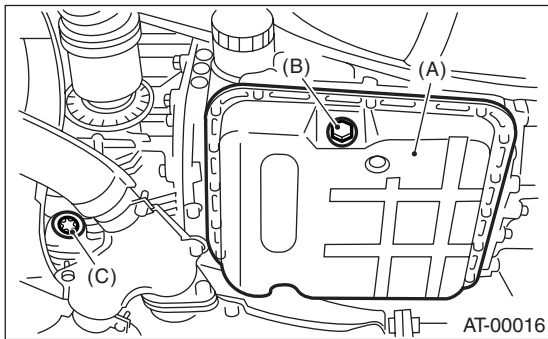

- (A) Oil pan
- (B) Drain plug (ATF)
- (C) Differential gear oil drain plug

- 4) Remove the oil pan.
- 5) Remove and clean the magnet.
- 6) Remove the old gasket on the oil pan and transmission case completely.

- 7) Disconnect each solenoid connector and remove ATF temperature sensor from control valve.

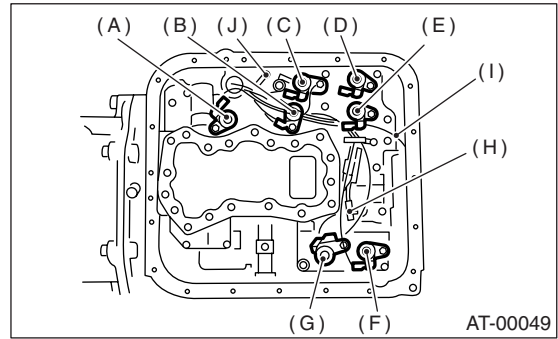

- (A) Lock-up duty solenoid (Blue)
- (B) Low clutch timing solenoid (Gray)
- (C) Line pressure duty solenoid (Red)
- (D) Shift solenoid 2 (Yellow)
- (E) Shift solenoid 1 (Green)
- (F) 2-4 brake timing solenoid (Black)
- (G) 2-4 brake duty solenoid (Red)
- (H) ATF temperature sensor
- (I) Transfer duty solenoid (Brown)
- (J) Transmission ground

- 8) Remove the control valve body.

NOTE:

When removing the control valve body, be careful not to interfere with transfer duty solenoid wiring.

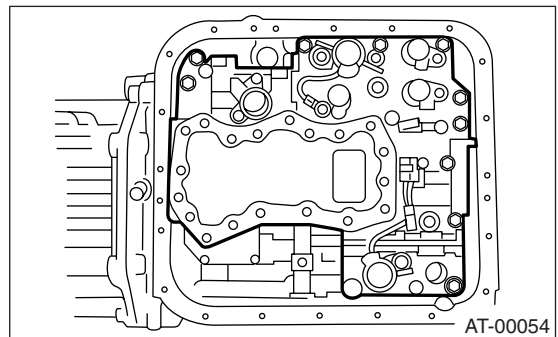

2. TURBO MODEL

- 1) Set the vehicle on a lift.
- 2) Disconnect the ground cable from battery.
- 3) Lift-up the vehicle.
- 4) Clean the transmission exterior.
- 5) Remove the drain plug (ATF) and gasket, and then drain ATF.

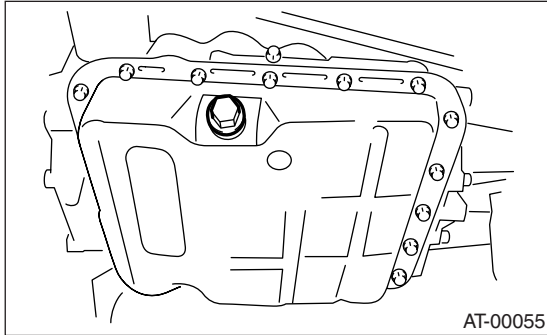

- 6) Replace the gasket with a new one, and then tighten the drain plug (ATF).

Tightening torque:

25 N·m (2.5 kgf·m, 18.1 ft·lb)

- 7) Remove the oil pan.

CAUTION:

Be careful not to allow dirt or dust to get into the oil pan.

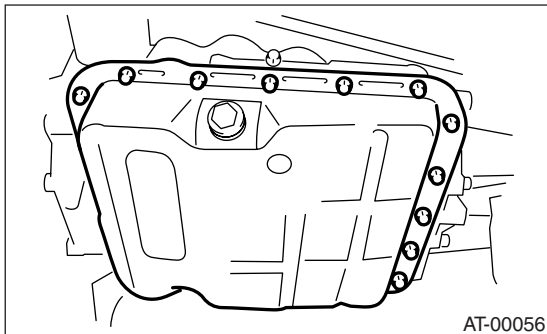

- 8) Remove the magnet.

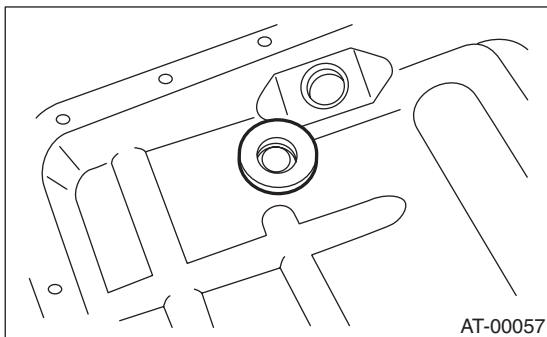

- 9) Clean the magnet.
- 10) Remove the liquid gasket completely from oil pan and transmission case.

- 11) Remove the control valve connector.

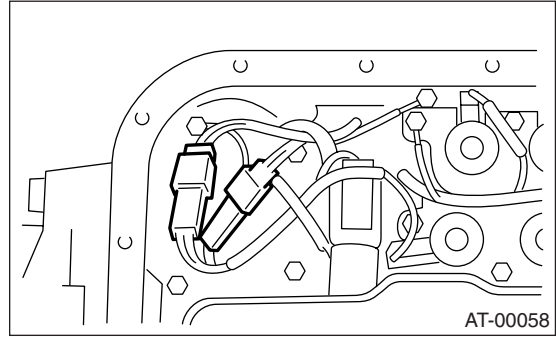

- 12) Remove the oil cooler pipe.

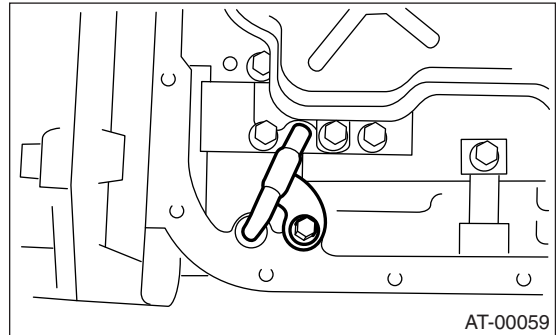

- 13) Remove the control valve body.

NOTE:

Replace the control valve body as assembly, because the control valve body can not be disassembled.

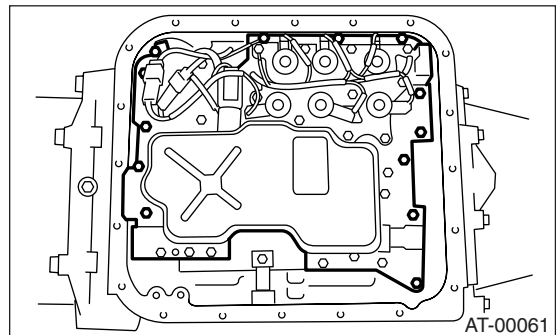

CONTROL VALVE BODY

AUTOMATIC TRANSMISSION

B: INSTALLATION

1. NON-TURBO MODEL

- 1) Set the range select lever in "N" range.
- 2) Install the control valve, ATF temperature sensor and ground connectors.

Tightening torque:

8 N·m (0.8 kgf·m, 5.8 ft·lb)

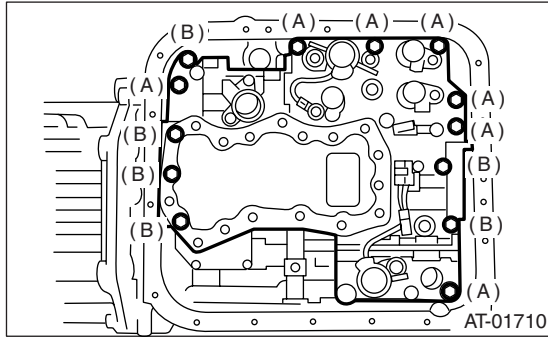

Bolt length mm (in)

(A) 30 (1.18)

(B) 55 (2.17)

- 3) Connect all connectors.

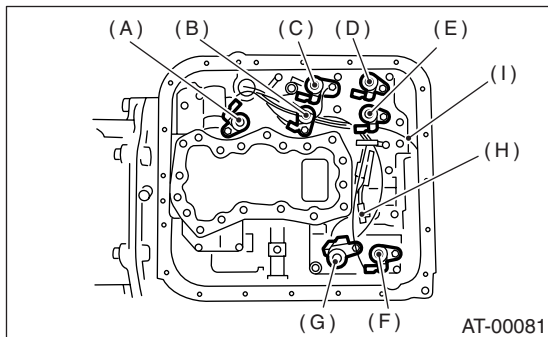

- (A) Lock-up duty solenoid (Blue)
- (B) Low clutch timing solenoid (Gray)
- (C) Line pressure duty solenoid (Red)
- (D) Shift solenoid 2 (Yellow)
- (E) Shift solenoid 1 (Green)
- (F) 2-4 brake timing solenoid (Black)
- (G) 2-4 brake duty solenoid (Red)
- (H) ATF temperature sensor
- (I) Transfer duty solenoid (Brown)

- 4) Attach the magnet at specified position.

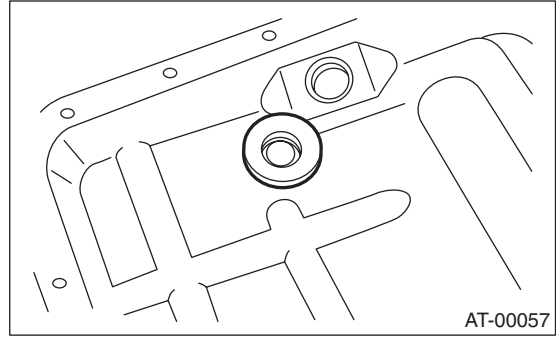

- 5) Apply proper amount of liquid gasket to the entire oil pan mating surface.

Liquid gasket:

THREE BOND 1217B (Part No. K0877YA020)

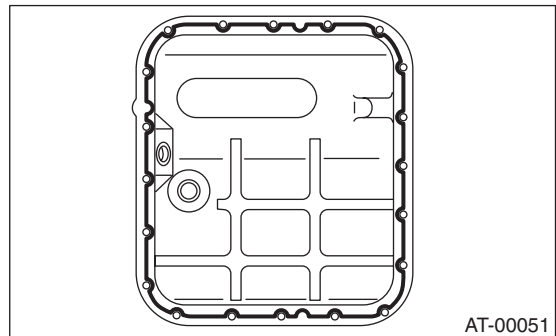

- 6) Apply liquid gasket fully to three holes other than screw holes on transmission case.

Liquid gasket:

THREE BOND 1217B (Part No. K0877YA020)

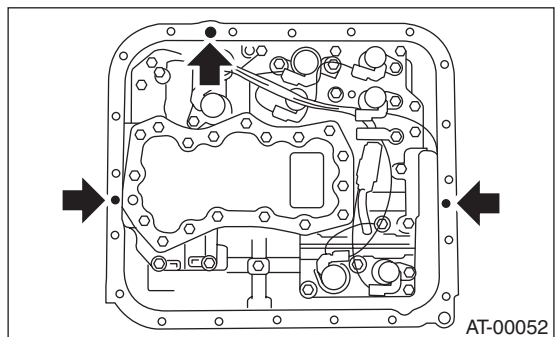

- 7) Install the oil pan by equally tightening bolts.

Tightening torque:

5 N·m (0.5 kgf·m, 3.6 ft·lb)

- 8) Pour ATF into the ATF charge pipe.

Recommended fluid:

Dexron III type automatic transmission fluid

Fluid capacity:

Fill the same amount of fluid drained from drain plug hole.

- 9) Bleed the air from control valve. <Ref. to 4AT-69, Air Bleeding of Control Valve.>

- 10) Check the level of ATF.
 <Ref. to 4AT-29, Automatic Transmission Fluid.>

2. TURBO MODEL

- 1) Check the control valve body for dirt and dust.
- 2) Install the control valve body and ground cable to transmission by tightening bolts evenly.

Tightening torque:

8 N·m (0.8 kgf·m, 5.8 ft·lb)

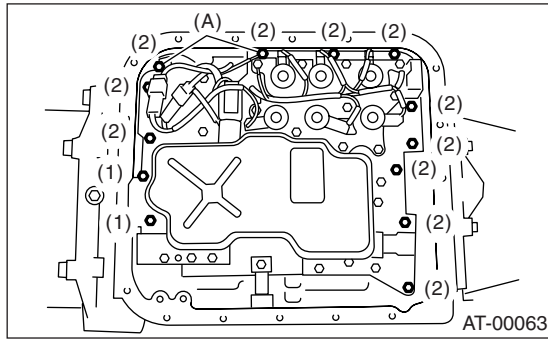

- (A) Transmission ground
 Bolt length mm (in)
- (1) 30 (1.18)
 - (2) 35 (1.38)

- 3) Attach the magnet at specified position of oil pan.

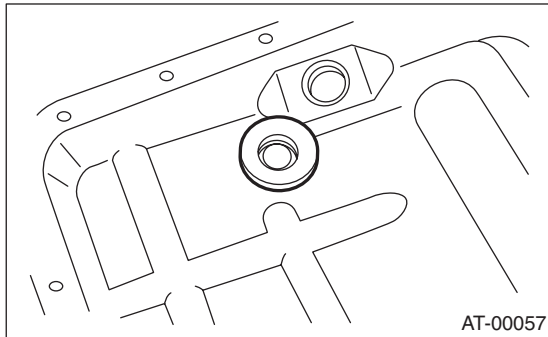

- 4) Apply proper amount of liquid gasket to the entire oil pan mating surface.

Liquid gasket:

THREE BOND 1217B (Part No. K0877YA020)

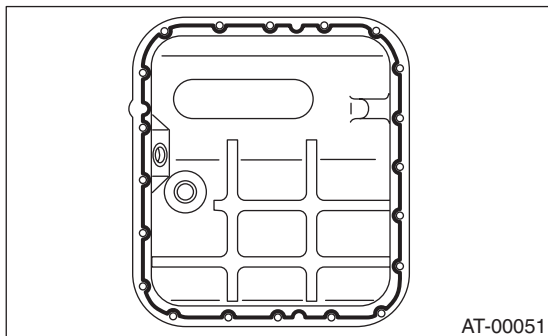

- 5) Apply liquid gasket fully to three holes other than screw holes on transmission case.

Liquid gasket:

THREE BOND 1217B (Part No. K0877YA020)

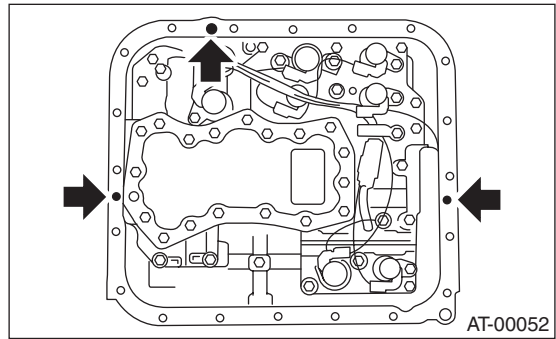

- 6) Install the oil pan with tightening bolts evenly.

Tightening torque:

5 N·m (0.5 kgf·m, 3.6 ft·lb)

- 7) Pour ATF into the ATF charge pipe.

Recommended fluid:

Dexron III type automatic transmission fluid

Fluid capacity:

Fill the same amount of fluid drained from drain plug hole.

- 8) Bleed the air from control valve. <Ref. to 4AT-69, Air Bleeding of Control Valve.>

- 9) Check the level of ATF. <Ref. to 4AT-29, Automatic Transmission Fluid.>

- 10) Perform the advance operation of learning control. (Turbo-model)

(1) Warm up the automatic transmission. (Raise the ATF temperature to 60 — 90°C (140 — 194°F).)

(2) Set the select lever to “P” range and apply parking brake, then lift-up the vehicle.

(3) Connect the SUBARU Select Monitor to vehicle.

(4) Using SUBARU Select Monitor, check that the DTC is not output.

(5) Using SUBARU Select Monitor, select the {2. Each System Check}→{Transmission Control System}→{Current Data Display & Save}→{12. Data Display}, and then indicate ATF Temp. data with using the scroll key.

(6) Using SUBARU Select Monitor, verify the ATF temperature is within a range of 60 — 90°C (140 — 194°F). During operation of the advance operation of learning control, leave the indication of SUBARU Select Monitor display as it is. <Ref. to 4AT(H4SO)-2, PROCEDURE, Basic Diagnostic Procedure.>

(7) Take all electrical load (headlight, air conditioner, seat heater, rear defogger, etc.) off the vehicle.

CONTROL VALVE BODY

AUTOMATIC TRANSMISSION

(8) With pressing shift lock release button, set the select lever to "R" range.

(9) Leave the vehicle for 30 seconds as it is.

(10) If error message "Communicate Failure" is indicated on the display of SUBARU Select Monitor, turn the ignition switch to ON with depressing the brake pedal. (Keep the brake pedal depressed after this step.)

(11) Confirm that display of SUBARU Select Monitor return to normal indication. (the error message is not shown.)

(12) Set the select lever to "P" range, and then wait for more than three seconds.

(13) Set the select lever to "R" range, and then wait for more than three seconds.

(14) Set the select lever to "N" range, and then wait for more than three seconds.

(15) Set the select lever to "D" range, and then wait for more than three seconds.

(16) Set the select lever to "N" range, and then wait for more than three seconds.

(17) Slightly depress the accelerator pedal to full open.

(18) Slightly release the accelerator pedal to full close.

(19) Start the engine.

(20) Shift the select lever to "D" range after the engine speed decreases and becomes stable.

(21) At this time, AT OIL TEMP warning light in the combination meter blinks at 2Hz.

(22) The advance operation of learning control is finished, when AT OIL TEMP warning light blink changes from 2Hz to 0.5Hz. If the interval of the blinking changes to 4 Hz (faster interval), the advance operation of learning control is not completed normally. Therefore, turn the ignition switch to OFF and repeat steps from 5).

(23) If the advance operation of learning control is completed normally, shift the select lever to "N" range. Turn the ignition switch to OFF and complete this operation.

CAUTION:

• After step 8), keep the brake pedal depressed till step 23). (If the brake pedal is released in the midst of operation, AT OIL TEMP warning light does not illuminate at step 21) or the interval of the blinking changes to 4 Hz.)

• Before operating the advance operation of learning control, perform Clear Memory Mode 2 and erase the back-up memory in TCM.

C: DISASSEMBLY

NON-TURBO MODEL ONLY

1) Remove oil strainer from lower control valve body.

NOTE:

Arrange the removed bolts in good order to assemble in the same place as disassembly, because the bolts length are different.

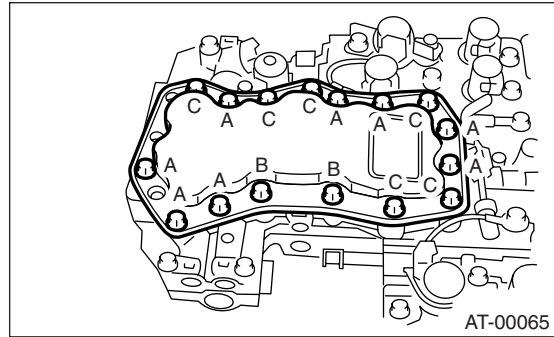

- (A) Short bolt
- (B) Middle bolt
- (C) Long bolt

2) Remove the duty solenoids, solenoids and sensor from the lower control valve body.

NOTE:

Arrange the removed bolts in good order to assemble in the same place as disassembly, because the bolts length are different.

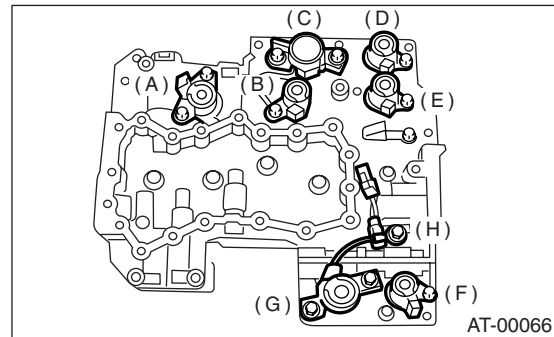

- (A) Lock-up duty solenoid (Blue)
- (B) Low clutch timing solenoid (Gray)
- (C) Line pressure duty solenoid (Red)
- (D) Shift solenoid 2 (Yellow)
- (E) Shift solenoid 1 (Green)
- (F) 2-4 brake timing solenoid (Black)
- (G) 2-4 brake duty solenoid (Red)
- (H) ATF temperature sensor

CONTROL VALVE BODY

AUTOMATIC TRANSMISSION

3) Remove the upper and lower control valve body tightening bolts.

NOTE:

Arrange the removed bolts in good order to assemble in the same place as disassembly, because the bolts length are different.

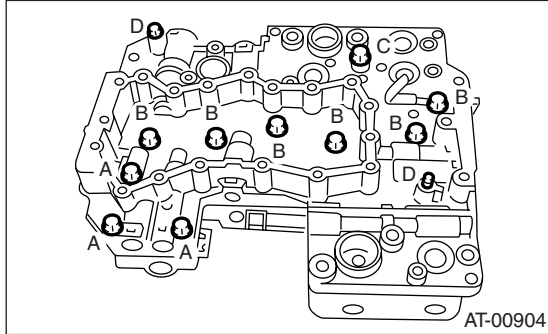

4) Remove the lower control valve body.
5) Remove the oil filter and separate plate.

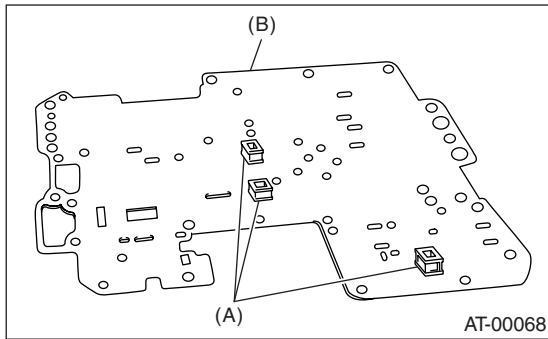

- (A) Oil filter
- (B) Separate plate

6) Remove six steel balls from middle control valve body.

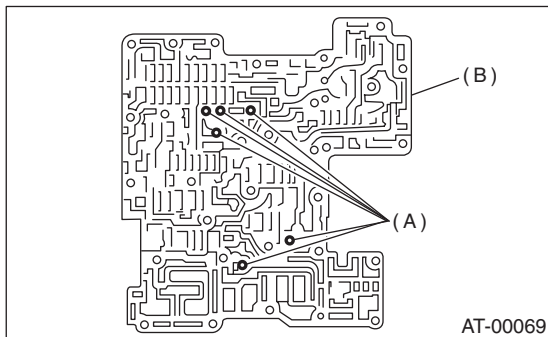

- (A) Steel ball
- (B) Middle control valve body

7) Remove the middle control valve body.

8) Remove upper separator plate from middle control valve body.

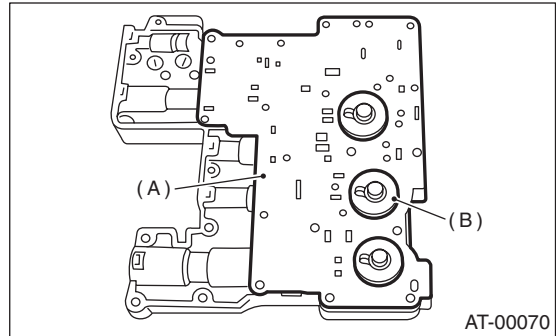

- (A) Upper separator plate
- (B) Side plate

9) Remove accumulator springs and four steel balls from upper control valve body.

10) Place a shop cloth to the piston removal hole.
11) Using an air compressor, apply air slowly to each piston hole and remove the accumulator pistons.

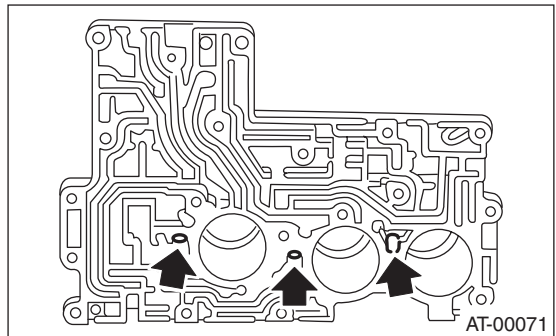

12) Remove the seal ring from accumulator piston.

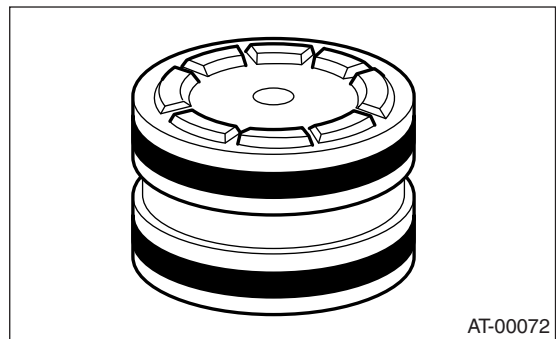

CONTROL VALVE BODY

AUTOMATIC TRANSMISSION

D: ASSEMBLY

1) Install a new seal ring to the accumulator piston.

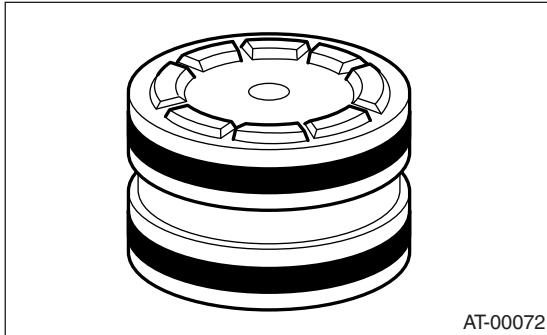

2) Apply ATF to the seal ring.

3) Insert the piston fully into upper control valve body.

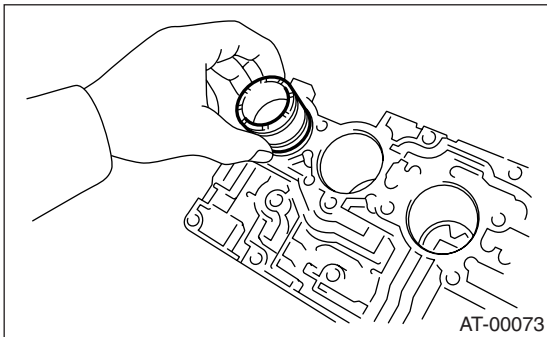

4) Install the accumulator spring and four steel balls to specified positions of upper control valve body.

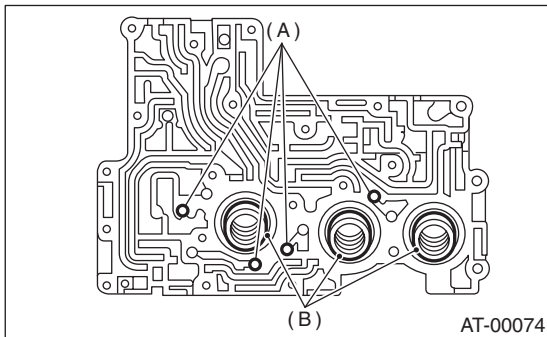

- (A) Steel ball
- (B) Accumulator spring

5) Align the hole in side plate with the hole in upper separator plate, and then install side plate and upper separator plate to middle control valve body.

Tightening torque:

8 N·m (0.8 kgf·m, 5.8 ft·lb)

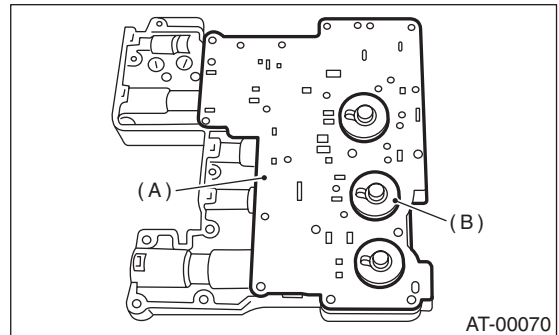

- (A) Upper separator plate
- (B) Side plate

6) Insert six steel balls in their proper positions to middle control valve body.

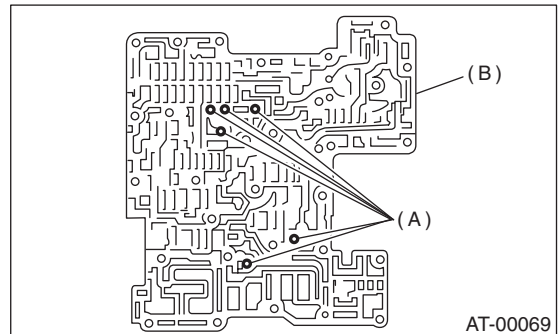

- (A) Steel ball
- (B) Middle control valve body

7) Install three oil filters to lower valve body.

NOTE:

Pay attention to the location of oil filters.

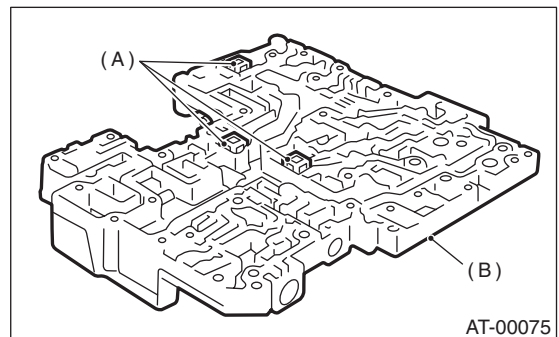

- (A) Oil filter
- (B) Lower control valve body

CONTROL VALVE BODY

AUTOMATIC TRANSMISSION

8) Install lower separate plate to lower control valve body.

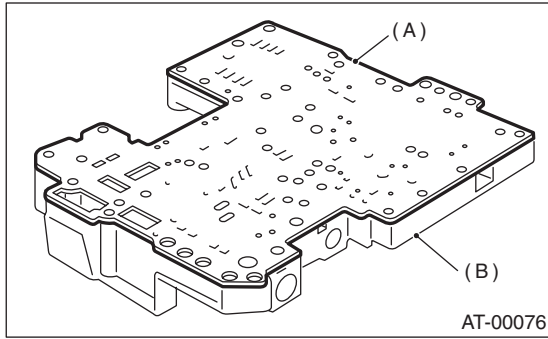

- (A) Lower separator plate
- (B) Lower control valve body

9) Temporarily assemble valve body.

NOTE:

Be careful not to drop the middle control valve body and upper control valve body interior steel ball, or the lower control valve body oil filter.

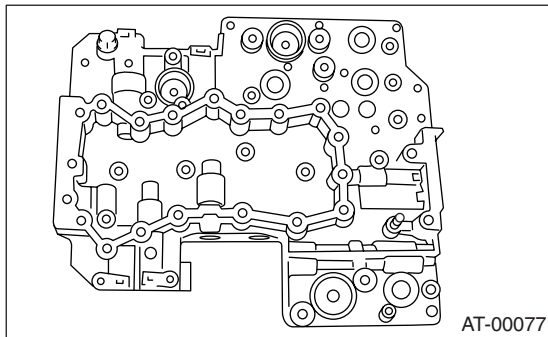

10) Tighten bolts.

NOTE:

Install the bolts (D) from upper control valve body side.

Tightening torque:

8 N·m (0.8 kgf-m, 5.8 ft-lb)

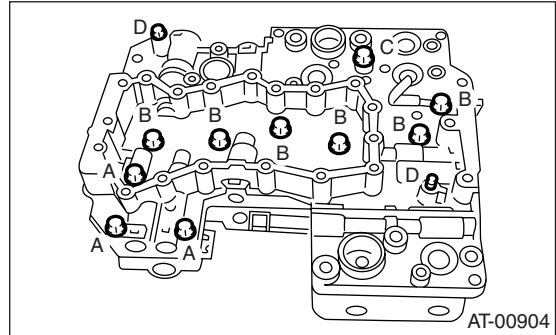

Bolt length mm (in)

- (A) 40 (1.57)
- (B) 62 (2.44)
- (C) 73 (2.87)
- (D) 79 (3.11)

11) Install the sensor, solenoids and duty solenoids to specified positions.

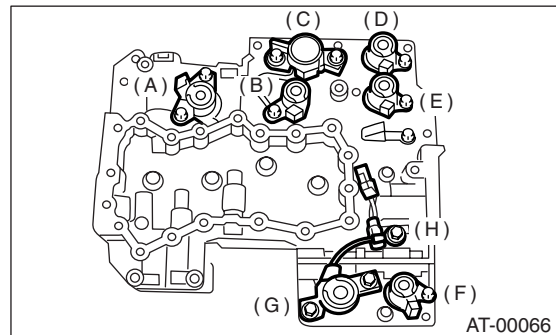

- (A) Lock-up duty solenoid (Blue)
- (B) Low clutch timing solenoid (Gray)
- (C) Line pressure duty solenoid (Red)
- (D) Shift solenoid 2 (Yellow)
- (E) Shift solenoid 1 (Green)
- (F) 2-4 brake timing solenoid (Black)
- (G) 2-4 brake duty solenoid (Red)
- (H) ATF temperature sensor

CONTROL VALVE BODY

AUTOMATIC TRANSMISSION

12) Tighten the bolts and nuts.

Tightening torque:

8 N·m (0.8 kgf·m, 5.8 ft-lb)

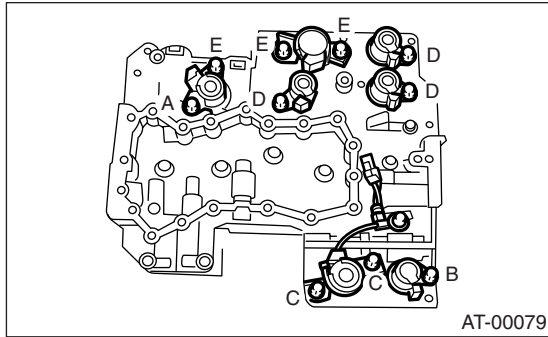

Bolt length mm (in)

- (A) 12 (0.47)
- (B) 40 (1.57)
- (C) 45 (1.77)
- (D) 62 (2.44)
- (E) 73 (2.87)

13) Install oil strainer to lower control valve body.

Tightening torque:

8 N·m (0.8 kgf·m, 5.8 ft-lb)

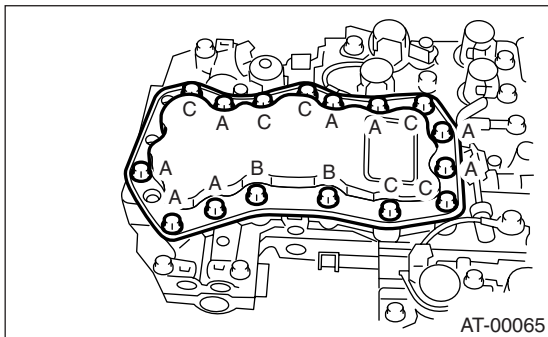

Bolt length mm (in)

- (A) 12 (0.47)
- (B) 62 (2.44)
- (C) 81 (3.19)

E: INSPECTION

Make sure that each component is free of harmful gouges, dents or dust.