

### 28.Extension Case

#### A: REMOVAL

1) Remove the transmission assembly. <Ref. to 4AT-39, REMOVAL, Automatic Transmission Assembly.>

2) Remove rear vehicle speed sensor.

- NON-TURBO MODEL

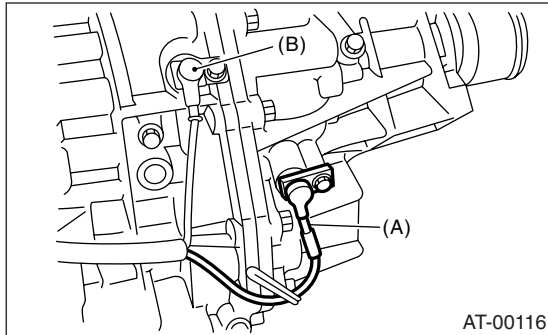

- (A) Rear vehicle speed sensor
- (B) Front vehicle speed sensor

- TURBO MODEL

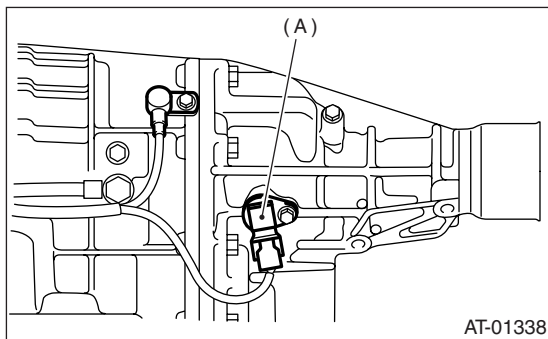

- (A) Rear vehicle speed sensor

3) Separate transmission case and extension case sections.

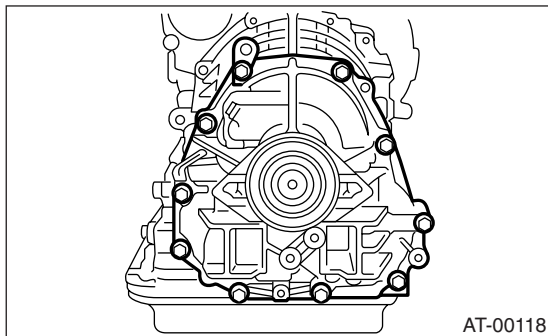

#### B: INSTALLATION

1) Apply Vaseline to the selected thrust needle bearing, and then attach the selected thrust needle bearing to the end surface of reduction drive gear. <Ref. to 4AT-90, ADJUSTMENT, Transfer Clutch.>

NOTE:

Install thrust needle bearing in the correct direction.

2) Install new gasket.

3) Install the extension case to the transmission case.

4) Tighten bolts to secure the case.

**Tightening torque:**

**25 N·m (2.5 kgf-m, 18.1 ft-lb)**

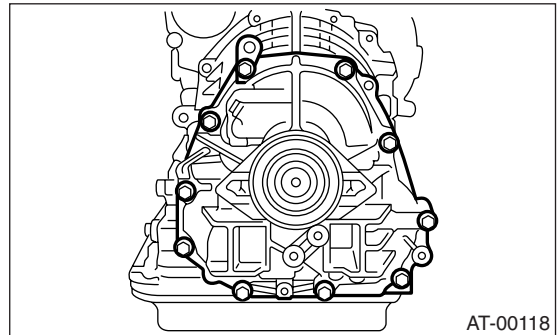

5) Install the rear vehicle speed sensor.

**Tightening torque:**

**7 N·m (0.7 kgf-m, 5.1 ft-lb)**

- NON-TURBO MODEL

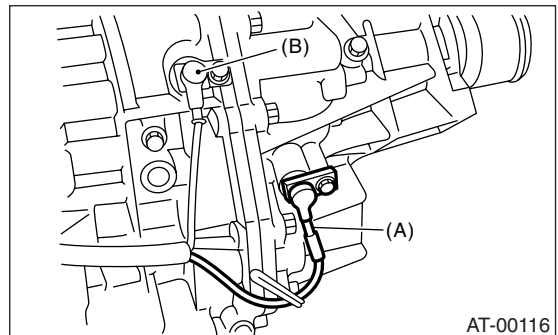

- (A) Rear vehicle speed sensor
- (B) Front vehicle speed sensor

# EXTENSION CASE

## AUTOMATIC TRANSMISSION

### • TURBO MODEL

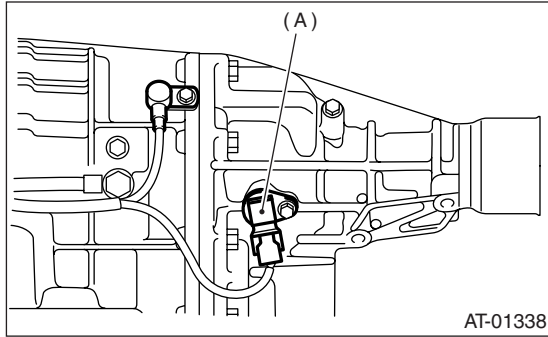

(A) Rear vehicle speed sensor

6) Install the transmission assembly. <Ref. to 4AT-42, INSTALLATION, Automatic Transmission Assembly.>

### C: DISASSEMBLY

1) Take out the transfer clutch assembly by lightly tapping the end of the rear drive shaft using a plastic hammer.

#### NOTE:

Be careful not to damage the oil seal in the extension.

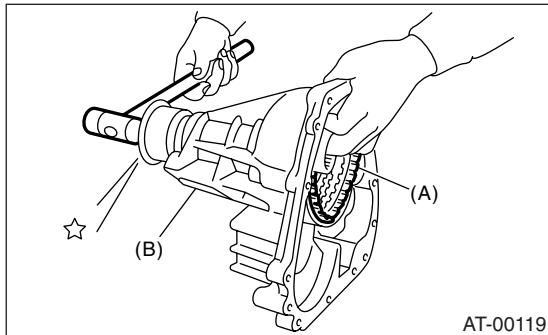

(A) Extension case  
(B) Transfer clutch ASSY

2) Remove the transmission clutch pipe without bending pipe.

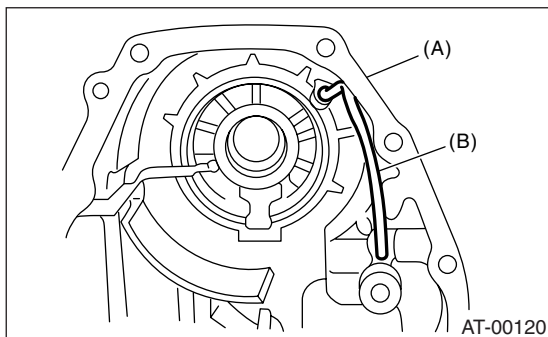

(A) Extension case  
(B) Transfer clutch pipe

3) Remove the dust cover from the extension case.  
4) Remove the oil seal from the extension case.

### D: ASSEMBLY

1) Using the ST and a press, press in a new oil seal.

ST 498057300 INSTALLER

2) Press in the dust cover.

3) Install the transfer clutch pipe to extension case without bending pipe.

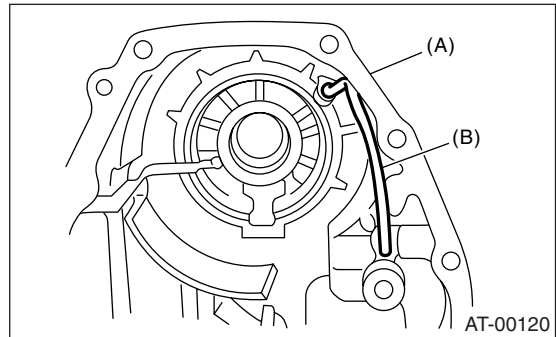

(A) Extension case  
(B) Transfer clutch pipe

4) Install the transfer clutch assembly to the case.

#### NOTE:

- Be careful not to damage the seal rings.
- Insert the transfer clutch assembly fully into position until the bearing shoulder bottoms.

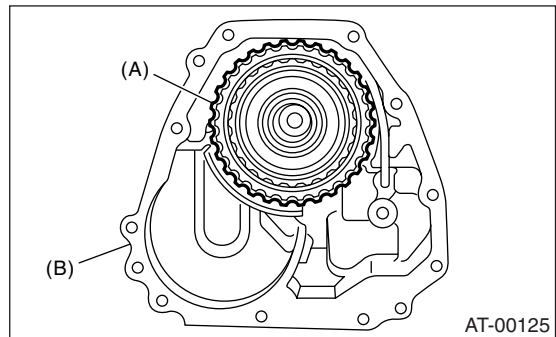

(A) Transfer clutch ASSY  
(B) Extension case

### E: INSPECTION

- Use forced air to make sure the transfer pipe and extension case routes are not clogged and do not leak.
- Measure the extension end play and adjust it to within specifications.

<Ref. to 4AT-90, ADJUSTMENT, Transfer Clutch.>