

38. Transmission Control Device

A: REMOVAL

- 1) Remove the transmission assembly from the vehicle. <Ref. to 4AT-39, REMOVAL, Automatic Transmission Assembly.>
- 2) Extract the torque converter clutch assembly. <Ref. to 4AT-84, REMOVAL, Torque Converter Clutch Assembly.>
- 3) Remove the input shaft.
- 4) Lift-up lever behind the transmission harness connector and disconnect it from stay.
- 5) Disconnect the air breather hoses. <Ref. to 4AT-82, REMOVAL, Air Breather Hose.>
- 6) Disconnect inhibitor switch connector from stay.
- 7) Wrap vinyl tape around the nipple attached to the air breather hose.
- 8) Remove pitching stopper bracket.
- 9) Remove the inhibitor switch.

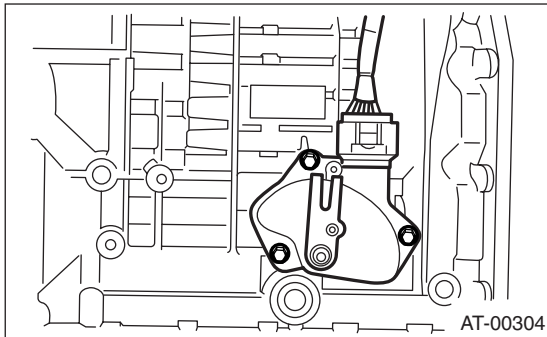

- 10) Remove control valve body assembly. <Ref. to 4AT-60, REMOVAL, Control Valve Body.>
- 11) Pull off the spring pin of manual plate.

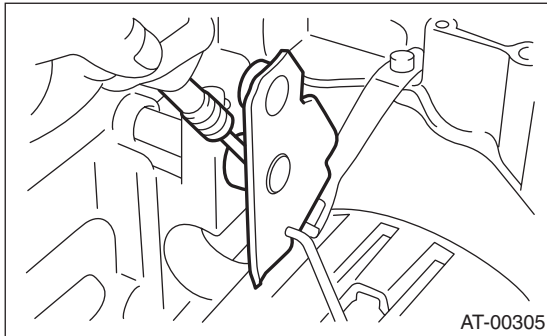

- 12) Remove bolts securing range select lever, then remove range select lever, manual plate and parking rod.

NOTE:

Be careful not to damage the lips of the press-fitted oil seal in the case.

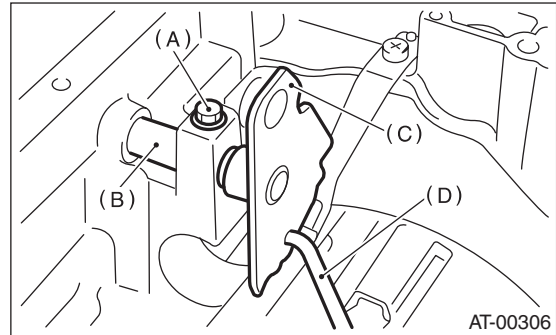

- (A) Bolt
- (B) Range select lever
- (C) Manual plate
- (D) Parking rod

- 13) Remove the detention spring.

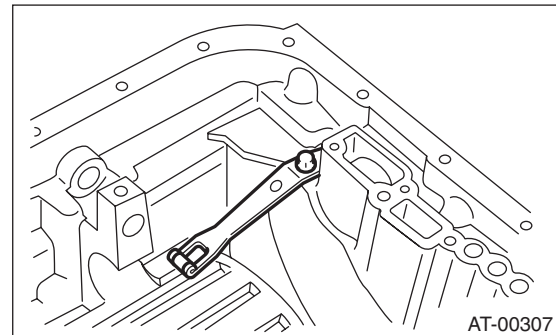

TRANSMISSION CONTROL DEVICE

AUTOMATIC TRANSMISSION

B: INSTALLATION

1) Install detention spring to transmission case.

Tightening torque:

6 N·m (0.6 kgf·m, 4.4 ft·lb)

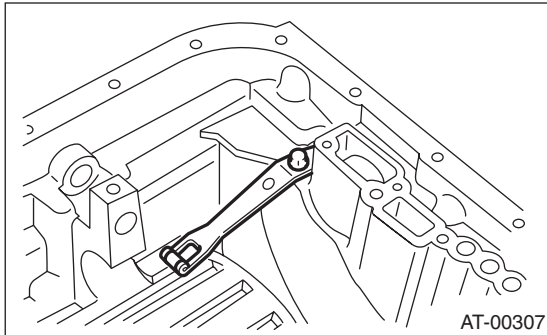

2) Insert range select lever, and tighten bolt.

Tightening torque:

6 N·m (0.6 kgf·m, 4.4 ft·lb)

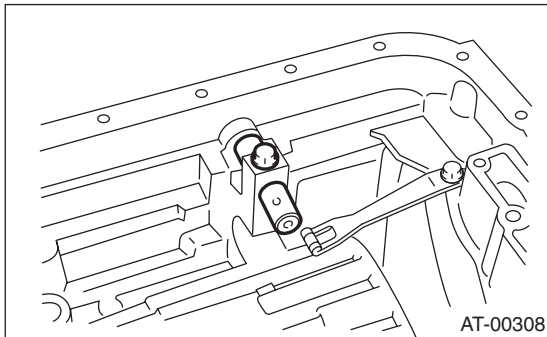

3) Insert manual plate and parking rod.

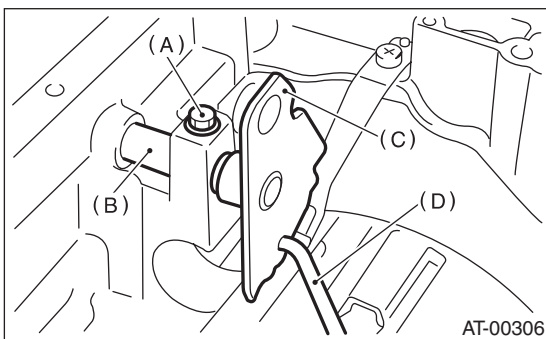

- (A) Bolt
- (B) Range select lever
- (C) Manual plate
- (D) Parking rod

4) Insert spring pin to manual plate.

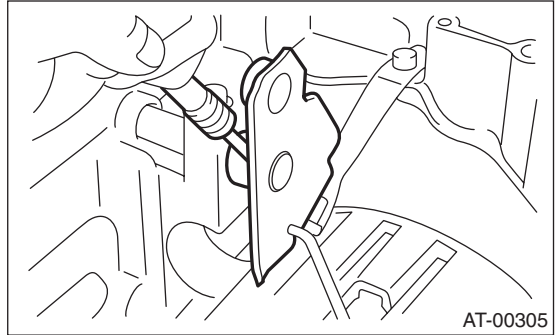

5) Install control valve assembly and oil pan. <Ref. to 4AT-62, INSTALLATION, Control Valve Body.>

6) Turn over the transmission case to its original position.

7) Install pitching stopper bracket.

Tightening torque:

41 N·m (4.2 kgf·m, 30.4 ft·lb)

8) Install inhibitor switch and adjust the inhibitor switch. <Ref. to 4AT-49, Inhibitor Switch.>

9) Insert inhibitor switch and transmission connector into stay.

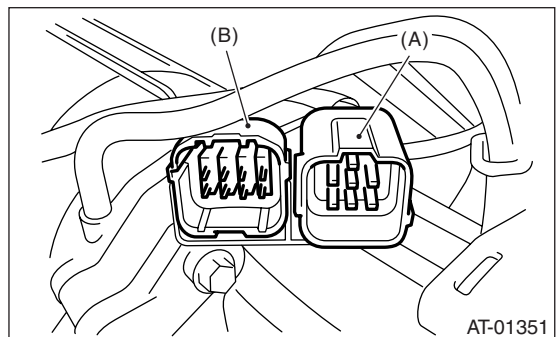

- (A) Transmission harness
- (B) Inhibitor switch harness

10) Install air breather hose. <Ref. to 4AT-82, INSTALLATION, Air Breather Hose.>

11) Insert the input shaft while turning lightly by hand and verify the protrusion amount.

Normal protrusion A:

50 — 55 mm (1.97 — 2.17 in)

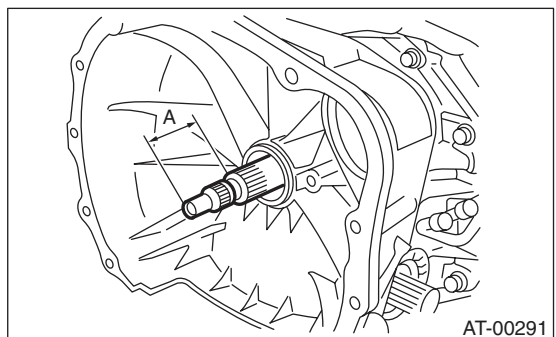

12) Install the torque converter clutch assembly.
<Ref. to 4AT-84, INSTALLATION, Torque Converter Clutch Assembly.>

13) Install the transmission assembly to the vehicle. <Ref. to 4AT-42, INSTALLATION, Automatic Transmission Assembly.>

C: INSPECTION

Make sure the manual lever and detention spring are not worn or otherwise damaged.

TRANSMISSION CONTROL DEVICE

AUTOMATIC TRANSMISSION
