

2. Clutch Disc and Cover

A: REMOVAL

1) Remove the transmission assembly from vehicle body. <Ref. to 5MT-28, REMOVAL, Manual Transmission Assembly.>

2) Install the ST on flywheel.

ST 499747100 CRANKSHAFT STOPPER

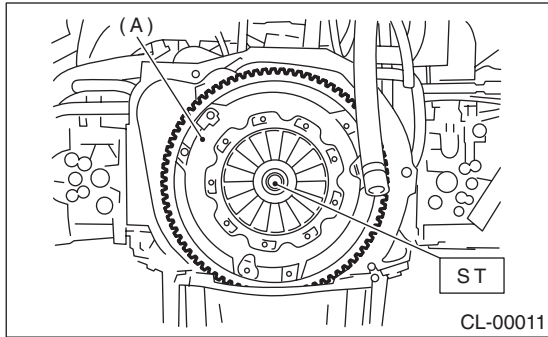

(A) Clutch cover

3) Remove the clutch cover and clutch disc.

NOTE:

- Take care not to allow oil on the clutch disc facing.
- Do not disassemble either the clutch cover or clutch disc.

B: INSTALLATION

1) Insert the ST into clutch disc and install them on the flywheel by inserting the ST end into pilot bearing.

NOTE:

When installing the clutch disc, be careful to its direction.

ST 499747100 CLUTCH DISC GUIDE

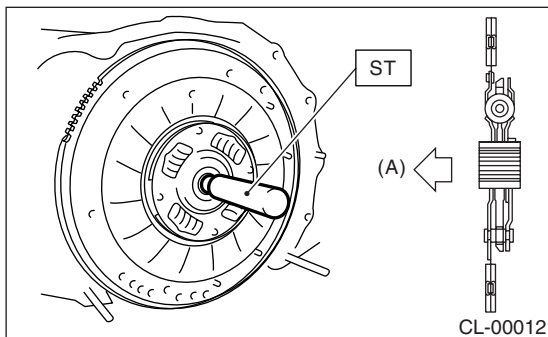

(A) Flywheel side

2) Position "0" marks on clutch cover and flywheel 120° apart, and then tighten the clutch cover installation bolts diagonally.

NOTE:

- "0" marks indicate the directions of residual unbalance.
- Temporarily tighten the bolts by hand. Each bolt should be tightened to the specified torque in a crisscross fashion.

Tightening torque:

16 N·m (1.6 kgf·m, 11.8 ft·lb)

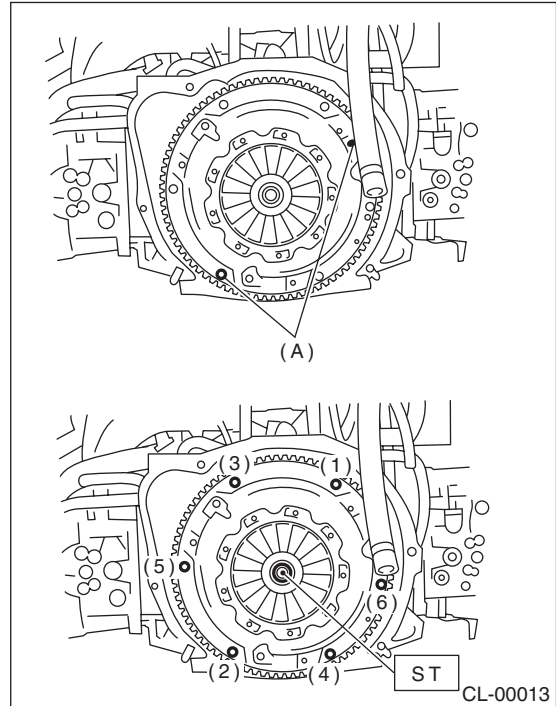

(A) "0" marks

3) Remove the ST.

ST 499747100 CLUTCH DISC GUIDE

4) Install the transmission assembly. <Ref. to 5MT-31, INSTALLATION, Manual Transmission Assembly.>

CLUTCH DISC AND COVER

CLUTCH SYSTEM

C: INSPECTION

1. CLUTCH DISC

1) Facing wear

Measure the depth of rivet head from the surface of facing. Replace if facings are worn locally or worn down to less than the specified value.

Depth of rivet head:

Limit of sinking

0.3 mm (0.012 in)

NOTE:

Do not wash the clutch disc with any cleaning fluid.

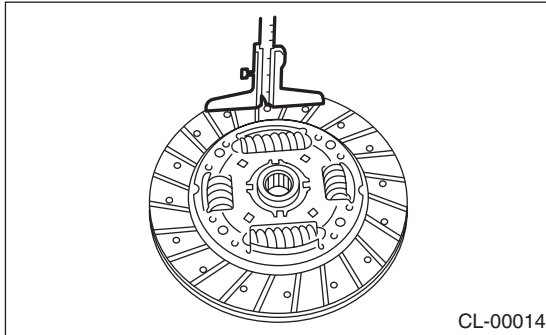

2) Hardened facing

Correct by using emery paper or replace.

3) Oil soakage on facing

Replace the clutch disc and inspect the transmission front oil seal, transmission case mating surface, engine rear oil seal and other points for oil leakage.

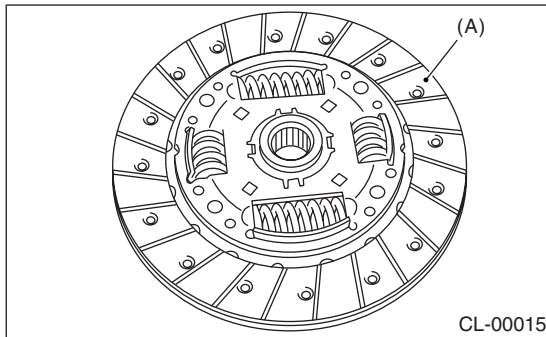

(A) Facing

4) Deflection on facing

If deflection exceeds the specified value at the outer circumference of facing, repair or replace.

ST 499747100 CLUTCH DISC GUIDE

Limit for deflection:

0.8 mm (0.031 in) at R = 107 mm (4.21 in)

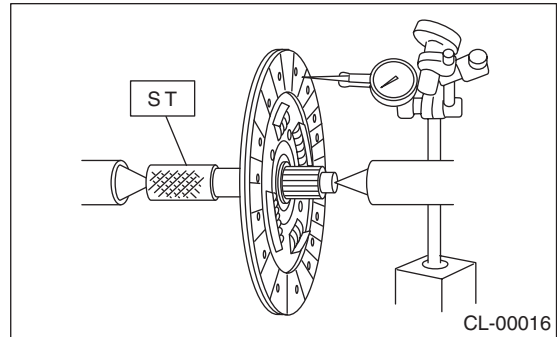

5) Worn spline, loose rivets and torsion spring failure

Replace defective parts.

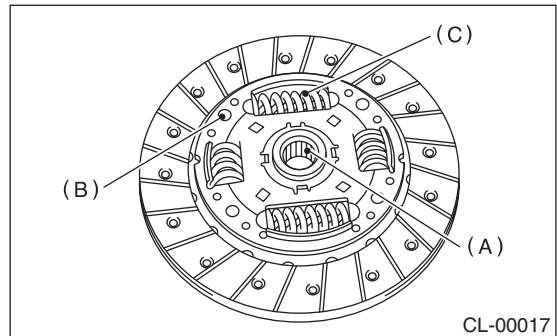

(A) Spline

(B) Rivet

(C) Torsion spring

2. CLUTCH COVER

NOTE:

Visually check for the following items without disassembling, and replace or repair if defective.

1) Loose thrust rivet.

2) Damaged or worn bearing contact area at center of diaphragm spring.

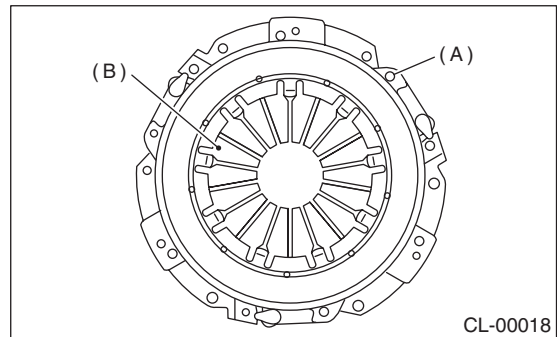

(A) Thrust rivet

(B) Diaphragm spring