

OIL PUMP

POWER ASSISTED SYSTEM (POWER STEERING)

7. Oil Pump

A: REMOVAL

- 1) Disconnect the ground cable from battery.
- 2) Remove the pulley belt cover.
- 3) Loosen the lock bolt and slider bolt, and then remove the power steering pump drive V-belt.

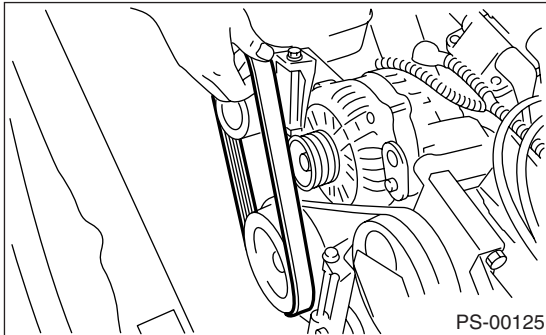

- 4) Disconnect the connector from power steering pump switch.
- 5) Disconnect the pipe C and suction hose from oil pump.

CAUTION:

- Do not allow fluid from the hose end to come into contact with pulley belt.
- To prevent foreign matter from entering the hose, cover the open ends of them with a clean cloth.

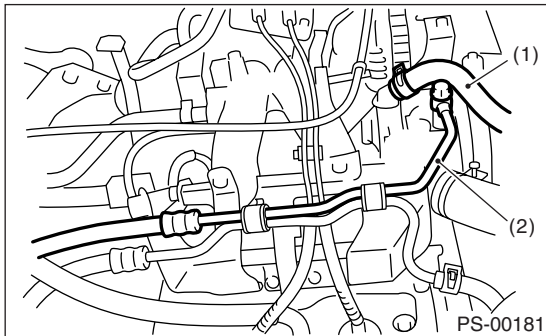

- (1) Suction hose
- (2) Pipe C

- 6) Remove the bolts which install power steering pump bracket.

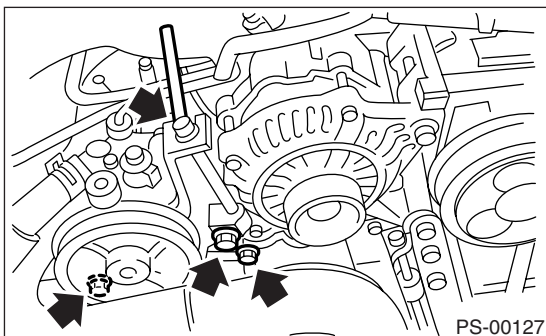

- 7) Place the oil pump bracket in a vise, remove the two bolts from front side of oil pump.

CAUTION:

Do not place the oil pump bracket directly in the vise; use soft pads and hold oil pump lightly to protect the pump.

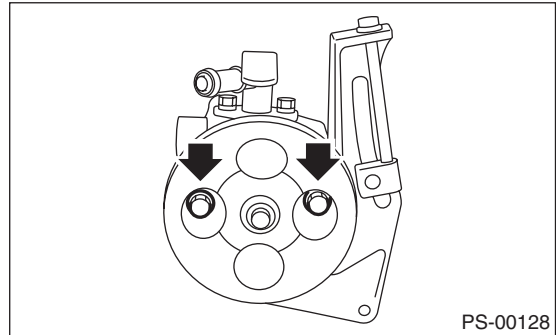

- 8) Remove the bolt from the rear side of oil pump.
- 9) Disassemble the oil pump and bracket by inserting a flat tip screwdriver as shown in the figure.

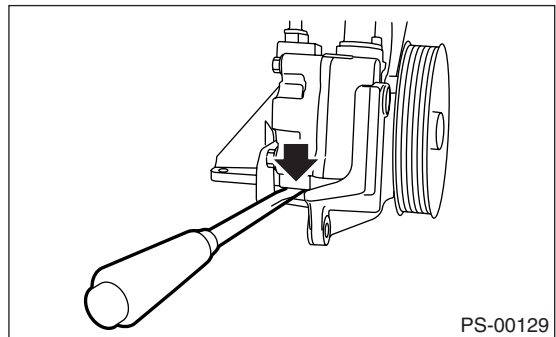

OIL PUMP

POWER ASSISTED SYSTEM (POWER STEERING)

B: INSTALLATION

1) Install the oil pump to bracket.

(1) Place the oil pump bracket in a vise. Tighten the bushing using a 12.7 mm (1/2") type 14 and 21 mm box wrench until it is in contact with the oil pump mounting surface.

CAUTION:

Do not place the oil pump bracket directly in the vise; use soft pads and hold oil pump lightly to protect the pump.

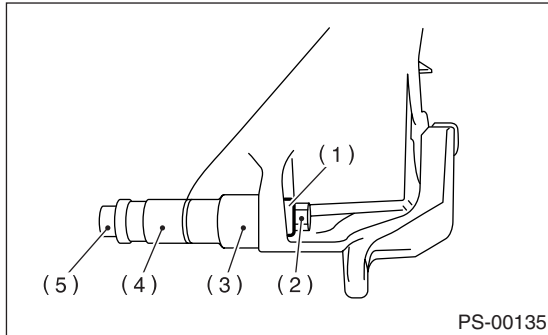

- (1) Bush
- (2) Nut
- (3) 21 mm
- (4) 14 mm
- (5) Bolt

(2) Installs oil pump to bracket.

Tightening torque:

15.7 (1.6 kgf-m, 11.6 ft-lb)

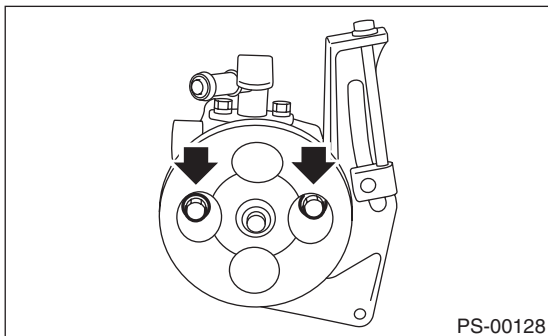

Tightening torque:

37.3 (3.8 kgf-m, 27.5 ft-lb)

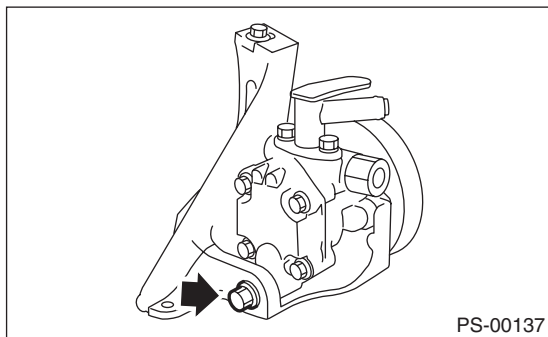

2) Tighten the bolt which installs power steering pump bracket.

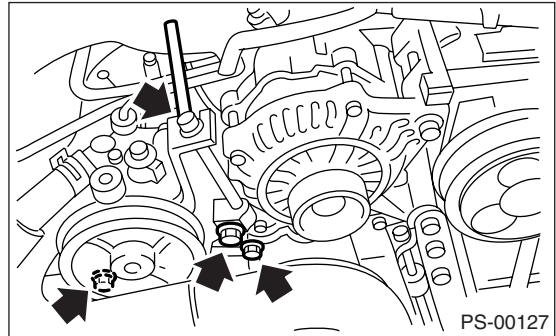

3) Interconnect the pipe C and suction hose to oil pump.

Tightening torque:

39 N-m (4.0 kgf-m, 28.9 ft-lb)

CAUTION:

If a hose is twisted, the hose may come into contact with some other parts.

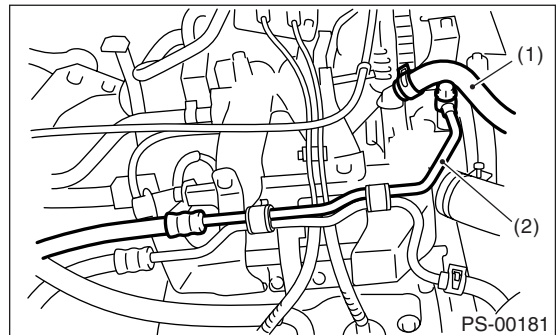

- (1) Suction hose
- (2) Pipe C

4) Connect the connector to power steering pump switch.

5) Install V-belt to oil pump.

6) Check the V-belt tension. <Ref. to ME(H4SO)-43, INSPECTION, V-belt.>

7) Tighten the bolt of belt tension.

Tightening torque:

8 N-m (0.8 kgf-m, 5.8 ft-lb)

8) Install the belt cover.

9) Connect the battery ground cable to battery.

10) Feed the specified power steering fluid. <Ref. to PS-52, Power Steering Fluid.>

CAUTION:

Never start the engine before feeding the fluid; otherwise vane pump might be seized up.

OIL PUMP

POWER ASSISTED SYSTEM (POWER STEERING)

C: INSPECTION

1. BASIC INSPECTION

Perform the following inspection procedures and repair or replace defective parts.

No.	Parts	Inspection	Corrective action
1	Oil pump (Exterior)	(1) Crack, damage or oil leakage	Replace the oil pump with a new one.
		(2) Play of pulley shaft	Measure the radial play and axial play. If any of these exceeds the service limit, replace the oil pump with a new one.
2	Pulley	(1) Damage	Replace it with a new one.
		(2) Bend	Measure the V ditch deflection. If it exceeds the service limit, replace the pulley with a new one.
3	Oil pump (Interior)	(1) Defect or burning of vane pump	Check the resistance to rotation of pulley. If it is past the service limit, replace the oil pump with a new one.
		(2) Bend in the shaft or damage to bearing	Oil pump emits a noise that is markedly different in tone and loudness from a sound of a new oil pump when turning with a string put around its pulley, replace the oil pump with a new one.
4	O-ring	Crack or deterioration	Replace it with a new one.
5	Bracket	Crack	Replace it with a new one.

2. SERVICE LIMIT

Make a measurement as follows. If it exceeds the specified service limit, replace the parts with new ones.

CAUTION:

- Fix the oil pump on a vise to make a measurement. At this time, hold the oil pump with least possible force between two wood pieces.
- Do not set outside of flow control valve or pulley on a vise; otherwise outside or pulley might be deformed. Select properly sized wood pieces.

1) Play of the pulley shaft

Condition:

When applying the force of 9.8 N (1.0 kgf, 2.2 lb)

Service limit:

Radial play (Direction \longleftrightarrow)
0.4 mm (0.016 in) or less

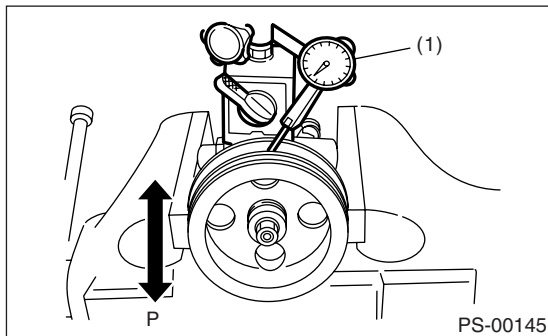

(1) Dial gauge

Axial play (Direction \longleftrightarrow)
0.9 mm (0.035 in) or less

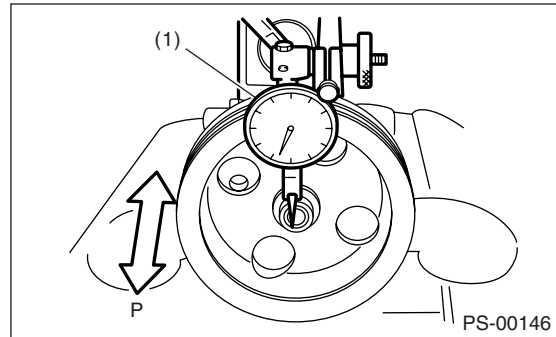

(1) Dial gauge

2) Ditch deflection of pulley

Service limit:

1.0 mm (0.039 in) or less

OIL PUMP

POWER ASSISTED SYSTEM (POWER STEERING)

NOTE:

Read the value for one surface of V ditch, and then the value for another off the dial.

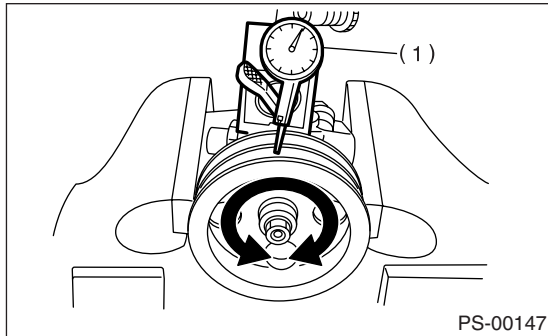

(1) Dial indicator

3) Resistance to rotation of pulley

Service limit:

Maximum load; 9.22 N (0.94 kgf, 2.07 lb) or less

NOTE:

- A rather higher value may be indicated when pulley starts turning.
- Measure the load during rotation and make a judgment.

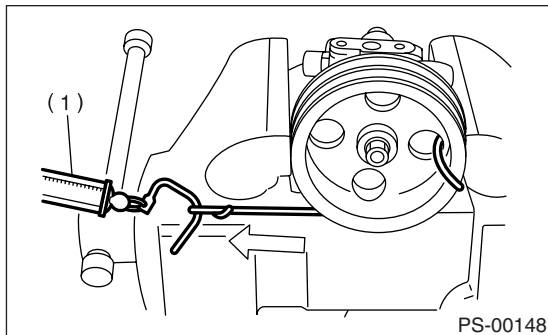

(1) Spring scale

3. HYDRAULIC PRESSURE

NOTE:

- Be sure to complete all items aforementioned in "INSPECTION", prior to measuring hydraulic pressure. Otherwise, pressure can not be measured correctly. <Ref. to PS-53, INSPECTION, General Diagnostic Table.>
- Do not leave the valve of pressure gauge closed or hold the steering wheel at stop end for 5 seconds or more in any case, as the oil pump may be damaged due to long keep of these conditions.
- Put a cotton cloth waste at a place where fluid drops before the pressure gauge is installed. Wipe off split fluid thoroughly after the measurement.

1) REGULAR PRESSURE MEASUREMENT

- (1) Connect the ST1, ST2 and ST3.
ST1 925711000 PRESSURE GAUGE
ST2 34099AC020 ADAPTER HOSE B
ST3 34099AC010 ADAPTER HOSE A
- (2) Remove the air intake duct.
- (3) Disconnect the pipe C from the pump.
- (4) Using the gasket (Part No. 34621AC021) and bolt (Part No. 34620AC010), install the ST2 to the pump instead of pipe C.

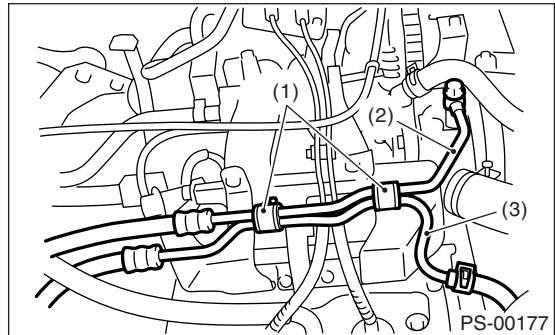

- (1) Bolt A
- (2) Pipe C
- (3) Pipe D

- (5) Install the ST3 to end of pipe C removed from pump.
 - (6) Replenish power steering fluid up to the specified level.
 - (7) Open the valve, and start the engine.
 - (8) Measure the regular pressure.
- ST1 925711000 PRESSURE GAUGE
ST2 34099AC020 ADAPTER HOSE B
ST3 34099AC010 ADAPTER HOSE A

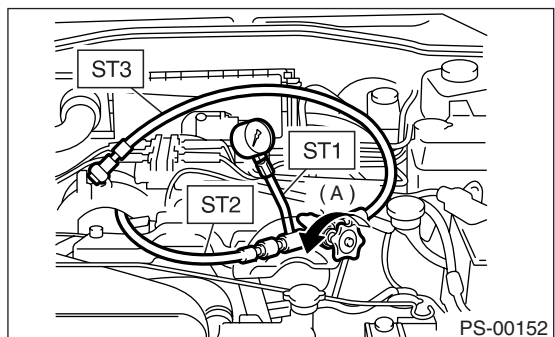

(A) Open

Service limit:

981 kPa (10 kg/cm², 142 psi) or less

- (9) If it is not within the specified value, replace the troubled part caused by the following symptoms; pipe or hose clogged, leaks from fluid line, and mix of foreign objects in fluid line.

OIL PUMP

POWER ASSISTED SYSTEM (POWER STEERING)

2) Measure the relief pressure.

- (1) Using the STs, measure the relief pressure.
- (2) Close the valve.
- (3) Measure the relief pressure.

ST1 925711000 PRESSURE GAUGE
ST2 34099AC020 ADAPTER HOSE B
ST3 34099AC010 ADAPTER HOSE A

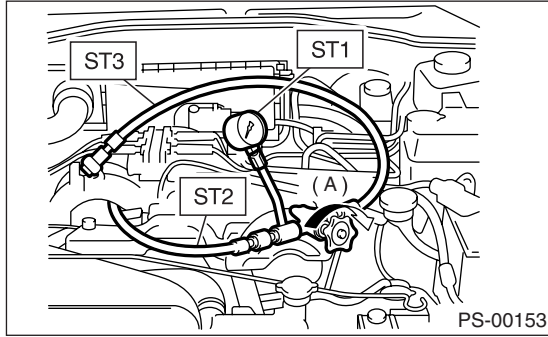

(A) Close

Service limit:

7,650 — 8,340 kPa

(78 — 85 kg/cm², 1,110 — 1,210 psi)

- (4) If it is not within the specified value, replace the oil pump.

3) Measure the working pressure.

- (1) Using the STs, measure the working pressure.
- (2) Open the valve.
- (3) Measure the working pressure of control valve by turning wheel from stop to stop.

ST1 925711000 PRESSURE GAUGE
ST2 34099AC020 ADAPTER HOSE B
ST3 34099AC010 ADAPTER HOSE A

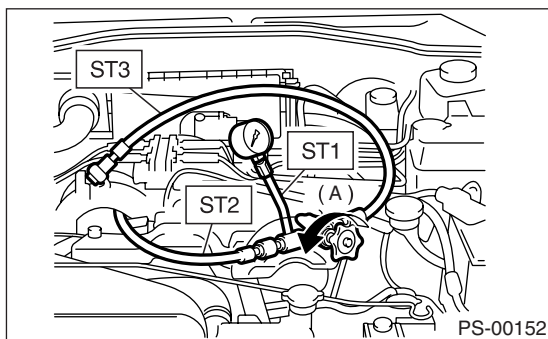

(A) Open

Service limit:

7,650 — 8,340 kPa

(78 — 85 kg/cm², 1,110 — 1,210 psi)

- (4) If it is within the specified value, measure the steering effort. <Ref. to PS-57, MEASUREMENT OF STEERING EFFORT, INSPECTION, General Diagnostic Table.> If it is not within specified value, replace the control valve itself or control valve and pinion as a single unit with new ones.