

TILT STEERING COLUMN

POWER ASSISTED SYSTEM (POWER STEERING)

4. Tilt Steering Column

A: REMOVAL

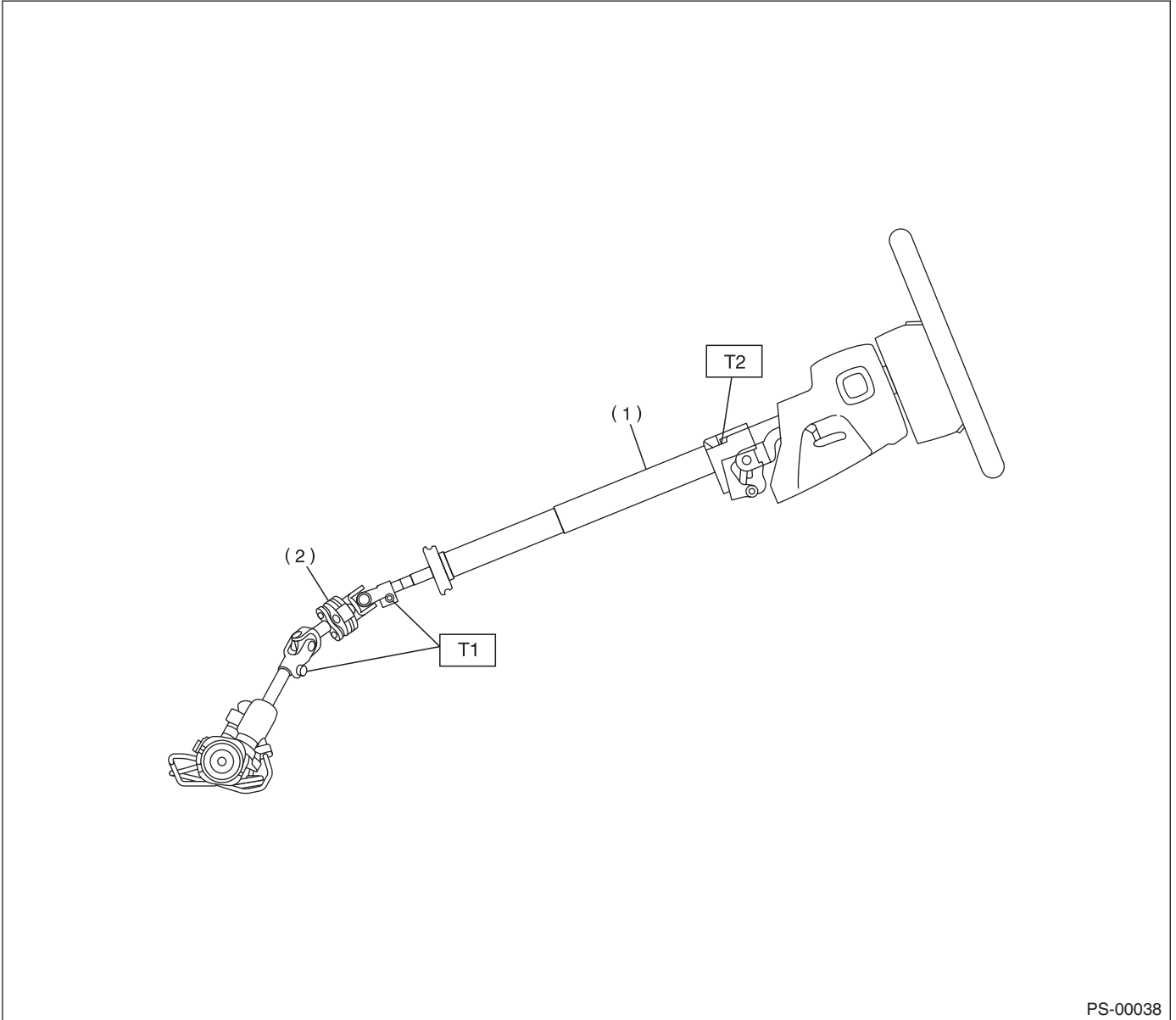

PS-00038

- (1) Tilt steering column
- (2) Universal joint

Tightening torque: N·m (kgf·m, ft·lb)

T1: 24 (2.4, 17.4)

T2: 25 (2.5, 18.1)

TILT STEERING COLUMN

POWER ASSISTED SYSTEM (POWER STEERING)

- 1) Set the vehicle on a lift.
- 2) Disconnect the ground cable from battery.
- 3) Remove the airbag module. <Ref. to AB-12, REMOVAL, Driver's Airbag Module.>

WARNING:

Always refer to "Airbag System" before performing airbag module service. <Ref. to AB-3, CAUTION, General Description.>

- 4) Remove the steering wheel. <Ref. to PS-15, REMOVAL, Steering Wheel.>
- 5) Remove the universal joint. <Ref. to PS-16, REMOVAL, Universal Joint.>
- 6) Remove the trim panel under instrument panel.
- 7) Remove the knee guard panel and steering column lower cover.

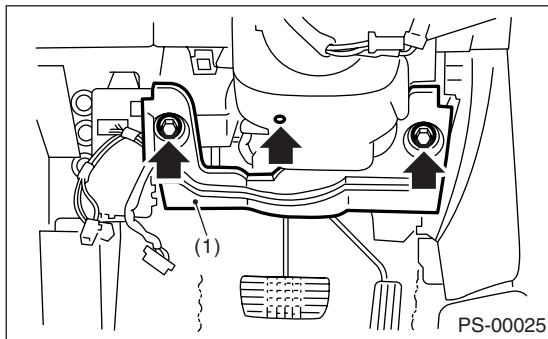

(1) Knee guard panel

- 8) Remove all connectors from steering column.
- 9) Remove the two bolts under instrument panel securing steering column.

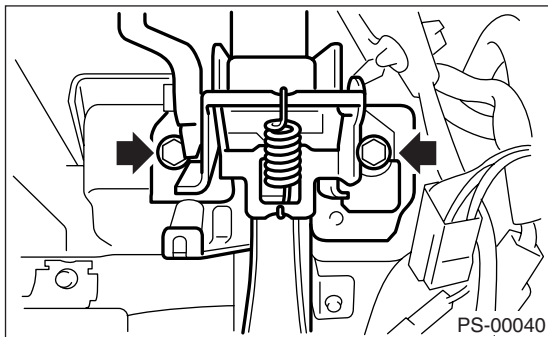

- 10) Pull out the steering shaft assembly from hole on toe board.

CAUTION:

- Be sure to remove the universal joint before removing steering shaft assembly installing bolts when removing steering shaft assembly or when lowering it for servicing of other parts.
- Do not loosen tilt lever when the steering column is not secured to the vehicle.

B: INSTALLATION

- 1) Set the grommet to toe board.

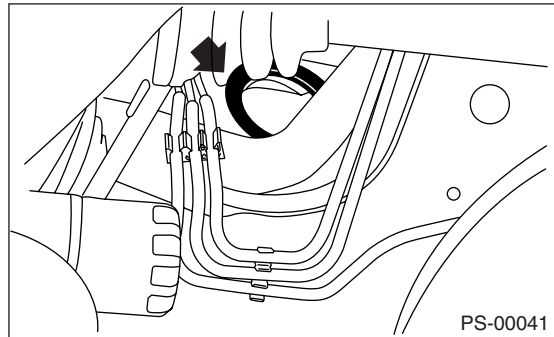

- 2) Insert the end of steering shaft into toe board grommet.
- 3) Tighten the steering shaft mounting bolts under instrument panel.

Tightening torque:

25 N·m (2.5 kgf-m, 18.1 ft-lb)

- 4) Connect all connectors under instrument panel.
- 5) Connect the airbag system connector at harness spool.

NOTE:

Make sure to apply double lock.

- 6) Install the lower column cover with tilt lever held in the lowered position.
- 7) Install the universal joint. <Ref. to PS-16, INSTALLATION, Universal Joint.>
- 8) Align center of roll connector. <Ref. to AB-18, ADJUSTMENT, Roll Connector.>
- 9) Install the steering wheel. <Ref. to PS-15, INSTALLATION, Steering Wheel.>

CAUTION:

Insert the roll connector guide pin into guide hole on lower end of surface of steering wheel to prevent damage.

- 10) Install the airbag module to steering wheel.

WARNING:

Always refer to "Airbag System" before performing the service operation. <Ref. to AB-3, CAUTION, General Description.>

C: DISASSEMBLY

Remove the two screws securing upper steering column covers, and two screws securing combination switch, and then remove the related parts.

TILT STEERING COLUMN

POWER ASSISTED SYSTEM (POWER STEERING)

D: ASSEMBLY

Insert the combination switch to upper column shaft, and then install the upper column cover. Then route the ignition key harness and combination switch harness between column cover mounting bosses.

Tightening torque:

1.2 N·m (0.12 kgf-m, 0.9 ft-lb)

CAUTION:

Do not overtorque the screw.

E: INSPECTION

1. BASIC INSPECTION

Measure overall length of the steering column. If not as specified, replace.

Standard value:

Overall length L

815.6±1.5 mm (32.11±0.059 in)

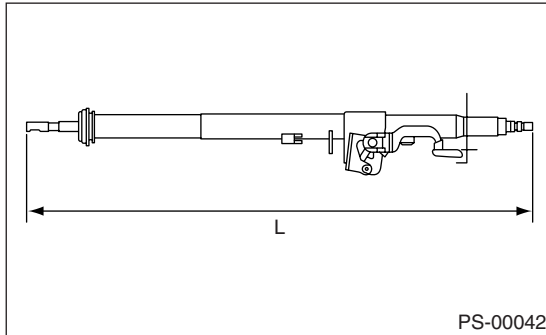

2. AIRBAG MODEL INSPECTION

WARNING:

For airbag model inspection procedures, refer to "Airbag System". <Ref. to AB-3, CAUTION, General Description.>