

5. Wheel Balancing

A: ADJUSTMENT

- 1) Remove the balance weights.
- 2) Using wheel balancer, measure the wheel balance.
- 3) Select a weight close to the value measured by wheel balancer.

Balance weight part number (For steel wheel)	Weight
28101TC000	5 g (0.18 oz)
28101SA060	10 g (0.35 oz)
28101SA070	15 g (0.53 oz)
28101SA080	20 g (0.71 oz)
28101SA090	25 g (0.88 oz)
723141340	30 g (1.06 oz)
723141350	35 g (1.23 oz)
723141360	40 g (1.41 oz)
723141370	45 g (1.59 oz)
723241380	50 g (1.76 oz)
723241580	55 g (1.94 oz)
723241590	60 g (2.12 oz)

Balance weight part number (For aluminum wheel)	Weight
28101SA000	5 g (0.18 oz)
28101SA010	10 g (0.35 oz)
28101SA020	15 g (0.53 oz)
28101SA030	20 g (0.71 oz)
28101SA040	25 g (0.88 oz)
23141GA512	30 g (1.06 oz)
23141GA522	35 g (1.23 oz)
23141GA532	40 g (1.41 oz)
23141GA542	45 g (1.59 oz)
23141GA552	50 g (1.76 oz)
—	55 g (1.94 oz)
23141GA572	60 g (2.12 oz)

- 4) Install the selected weight to the point designated by wheel balancer.
- 5) Using wheel balancer, measure the wheel balance again. Check that the wheel balance is correctly adjusted.
- 6) Use genuine balance weights.

NOTE:

- 55 g (1.94 oz) weight used with the aluminum wheel is not available.

- Balance weights are available for use with any of 15- to 16-inch wheels.

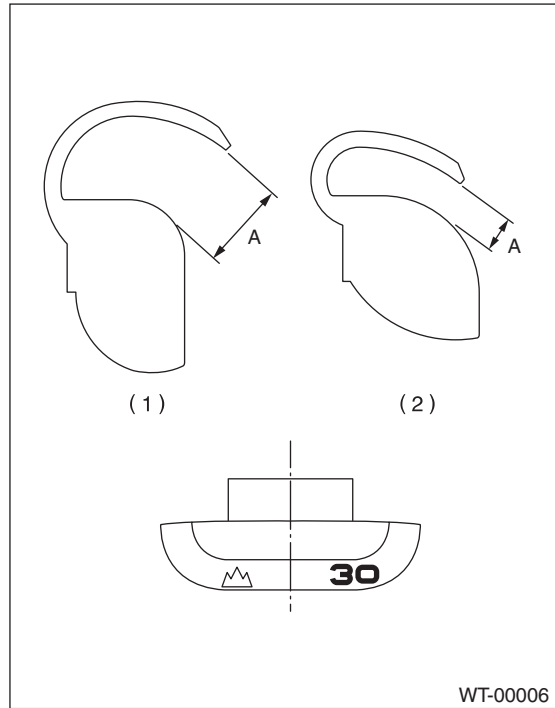

- (1) Weight for aluminum wheel
- (2) Weight for steel wheel

Service limit: A

Weight for steel wheel;

5 g (0.18 oz) — 25 g (0.88 oz) 2.0 mm (0.079 in)
30 g (1.06 oz) 1.8 mm (0.071)

Weight for aluminum wheel;

5 g (0.18 oz) — 25 g (0.88 oz) 5.0 mm (0.197 in)
30 g (1.06 oz) 4.5 mm (0.177 in)