

1. Pre-delivery Inspection

A: GENERAL

The purposes of the pre-delivery inspection (PDI) are as follows.

- Remove the additional parts used for ensuring the vehicle quality during transportation and restore the vehicle to its normal state.
- check that the vehicle before delivery is in a normal state.
- Check for any damage or missing parts that may have taken place during transportation or storage.
- Make sure to provide a complete vehicle to the customer.

Because of the above reasons, all SUBARU distributor service must always carry out the PDIs before delivering a vehicle.

In addition, all franchised shops and PDI centers must check the status of every vehicle received to identify who is responsible for any possible defects.

B: PDI PROCEDURE

Follow the procedures shown in the table below.

Static Checks Just After Vehicle Receipt

Step	Check point
1. Appearance check	(1) If the vehicle is covered with protective coating, visually check the vehicle body for damage and dents. If the protective coating has been removed, visually check the body paints for small areas of damage or stains. (2) Visually check the glass and light lenses for any damage and cracks or excessive gaps to the body sheet metal. (3) Visually check the plated parts for any damage.
2. Tire check	(1) Check the tires for damage, abnormal conditions, and dents on the wheels. (2) Check the tire air pressure.
3. Fuse installation	If the vehicle is about to be delivered to the customer, attach a room light fuse.
4. Connection of air conditioner harness	If the vehicle is about to be delivered to the customer, connect the air conditioner harness.
5. Check the doors for lock/unlock and open/close operations.	(1) Using the key, check that the door can be locked and unlocked normally. (2) Open and close all doors to see that there are no abnormal conditions.
6. Operation check of the child safety lock system	Check that the child safety lock system operates normally.
7. Check the trunk lid for open/close operations.	(1) Operate the trunk lock release lever to check that the trunk opens normally. (2) Using the key, check that the trunk lid can be unlocked normally. (3) Open and close the trunk lid to see that there are no abnormal conditions.
8. Check the rear gate for lock/unlock and open/close operations.	(1) Check if the rear gate can be unlocked normally through the emergency hole. (2) Open and close the rear gate to see that there are no abnormal conditions. (3) Operate the power door locking switch to check that the rear gate is locked and unlocked normally.
9. Operation check of trunk lid release handle.	Operate the trunk lid release handle to check that the trunk lock opens normally.
10. Operation check of fuel lid opener lock release lever	Operate the fuel lid opener to check that the fuel lid is unlocked normally.
11. Accessory check	Check that the following accessories are provided: <ul style="list-style-type: none"> • Owner's manual • Warranty booklet • Service booklet • Spare key • Jack • Tool set • Spare tire
12. Operation check of hood lock release system	Operate the hood lock release lever to check that the hood opens normally.
13. Battery	Check the battery for any abnormal conditions such as rust and trace of battery fluid leaks.
14. Brake fluid	Check the fluid amount.
15. Engine oil	Check the oil amount.
16. Transmission fluid	Check the fluid amount.
17. AT front differential oil	Check the AT front differential oil amount.
18. Coolant	Check the coolant amount.
19. Clutch fluid	Check the clutch fluid amount.
20. Window washer fluid	Check the window washer fluid amount.
21. Hood latch check	Check that the hood is closed and latched securely.
22. Keyless entry system	Check that the keyless entry system operates normally.
23. Security system	Check that the security system operates normally.
24. Seat	(1) Check the seat surfaces for smears or dirt. (2) Check the seat installation conditions and functionality.

PRE-DELIVERY INSPECTION

PRE-DELIVERY INSPECTION

Step	Check point
25. Seat belt	Check the seat belt installation conditions and functionality.
26. Wheel alignment	Check that the wheel alignments are properly adjusted.

Checks with the Engine Running

Step	Check point
27. Test mode connector	Test mode connector.
28. Starting condition	Start the engine and check that the engine starts smoothly.
29. Exhaust system	Check that the exhaust noise is normal and no leaks are found.
30. Indicator light	Check that all the indicator lights operate normally.
31. Clock	Check that the clock operates normally.
32. Radio	Check that the radio system operates normally.
33. Front accessory power supply socket	Check that the front accessory power supply socket operates normally.
34. Lighting system	Check that the lighting systems operate normally.
35. Window washer	Check that the window washer system operates normally.
36. Wiper	Check that the wiper system operates normally.
37. Power window operation check	Check the power window for correct operations.

Dynamic Test with the Vehicle Running

Step	Check point
38. Brake test	Check that the foot brake operates normally.
39. Parking brake	Check that the parking brake operates normally.
40. AT shift control	Check the AT shift patterns are correct.
41. Heater & ventilation	Check that the heater & ventilation system operates normally.
42. Air conditioner	Check that the air conditioner operates normally.
43. Cruise control	Check that the cruise control system operates normally.

Checks after Dynamic Test

Step	Check point
44. ATF level	Check that the ATF level is normal.
45. Power steering fluid level	Check that the power steering fluid level is normal.
46. Fluid leak check	Check for fluid/oil leaks.
47. Water leak check	Spray the vehicle with water and check for water leaks.
48. Appearance check 2	(1) Remove the protective coating (if any). (2) Check the body paints for damage and smears. (3) Check the plated parts for damage and rust.

1. APPEARANCE CHECK

- If the vehicle is covered with protective coating, visually check the vehicle body for damage and dents.
- If there is no protective coating, check the body paints for small areas of damage or stains and repair as necessary.
- Check the window glass, door glass, and lights for any cracks or damage and repair or replace the parts as necessary.
- Check the plated parts, such as the grilles and door knobs, for damage or loss of gloss and repair or replace the parts as necessary.

2. TIRE CHECK

- Check the tire outer faces for any damage.
- Check the tire air pressure by referring to the following table.

Tire size	Tire inflation pressure kPa (kg/cm ² , psi)	
	Front	Rear
P195/60R15	220 (2.2, 32)	200 (2.0, 29)
P205/55R16	220 (2.2, 32)	200 (2.0, 29)
215/45R17	230 (2.3, 33)	220 (2.2, 32)
225/45ZR17	250 (2.5, 36)	210 (2.1, 30)

3. FUSE INSTALLATION

A vehicle just delivered has no fuse for the room light circuit to prevent battery discharge. Attach a 15 A fuse (A) as shown in the figure.

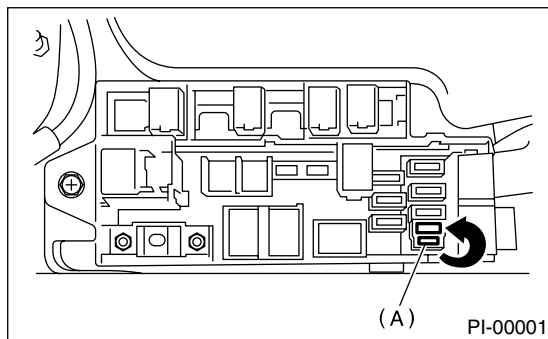

4. CONNECTION OF AIR CONDITIONER HARNESS

A vehicle just delivered has its air conditioner harness disconnected to protect the air conditioner compressor. Connect the harness as shown in the figure.

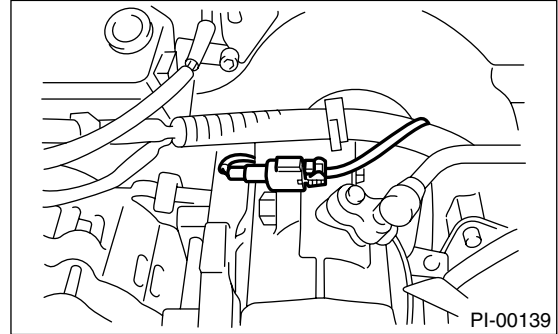

5. CHECK THE DOORS FOR LOCK/UNLOCK AND OPEN/CLOSE OPERATIONS

1) Using the key, lock and unlock the door several times to check for normal operation. Open and close the door several times for smooth movement.

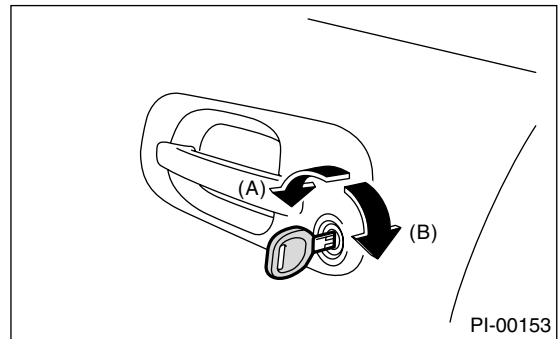

- (A) Unlock
- (B) Lock

PRE-DELIVERY INSPECTION

PRE-DELIVERY INSPECTION

2) Close the driver's door completely, and place the door lock knob (A) to the lock position. Then pull inner remotes (B) to ensure that doors will not open. For other doors, place the door lock knob (A) to the lock positions and then pull the inner remote to ensure that the doors will not open.

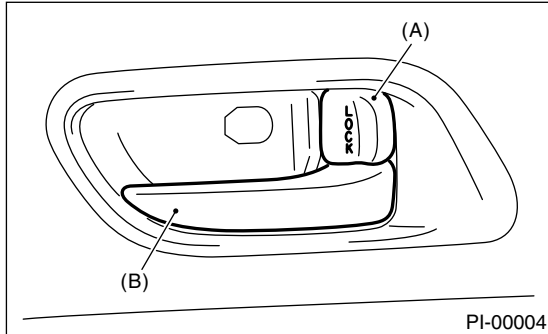

- (A) Door lock knob
- (B) Inner remote

3) Press the driver's and passenger's side power door lock switch to lock side. Check that all doors including rear gate are locked.

- Driver's side

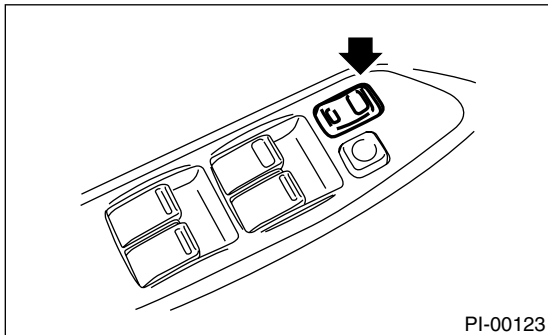

- Passenger's side

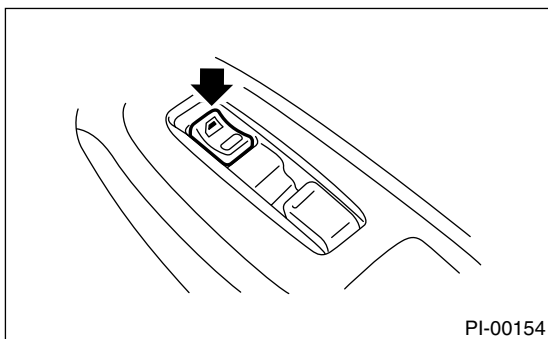

4) Press the driver's and passenger's side power door lock switch to unlock side. Check that all doors including rear gate are unlocked.

- Driver's side

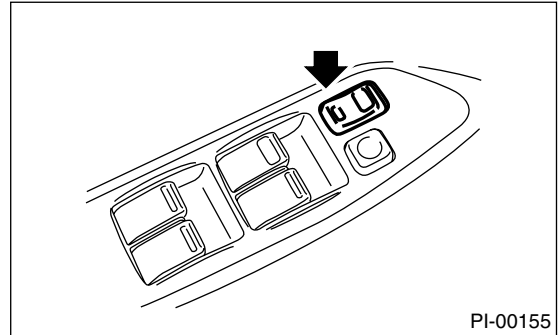

- Passenger's side

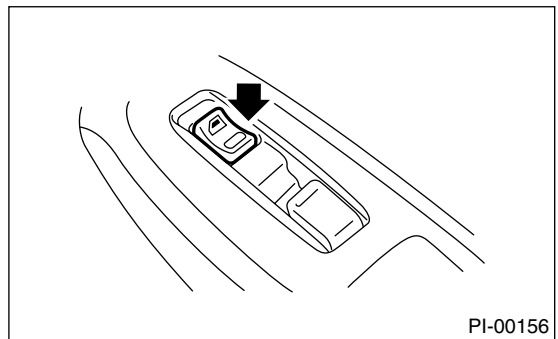

6. CHECK THE OPERATION OF CHILD SAFETY LOCKS SYSTEM

- 1) Set the child safety lock on both rear doors to the lock positions.
- 2) Close the rear doors completely.
- 3) Check that the lock levers of the rear doors are in the unlock positions. Then, pull the inner remotes of the rear doors to ensure that the doors will not open.
- 4) Next, pull the outside door handles of the rear doors to ensure that the doors will open.

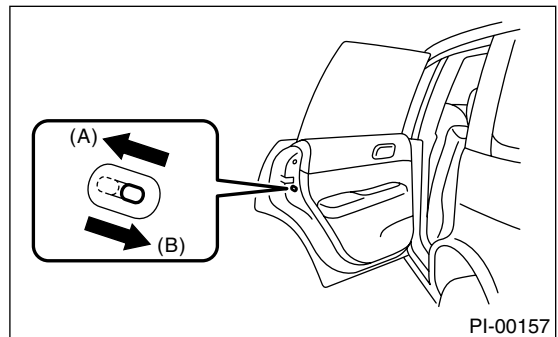

- (A) Unlock
- (B) Lock

7. CHECK THE TRUNK LID FOR OPEN/CLOSE OPERATIONS

- 1) Operate the trunk lock release lever and verify that the trunk lid opens.
- 2) Using the key, open the trunk lid several times to check for normal operation.
- 3) Open and close the trunk lid several times for smooth movement.

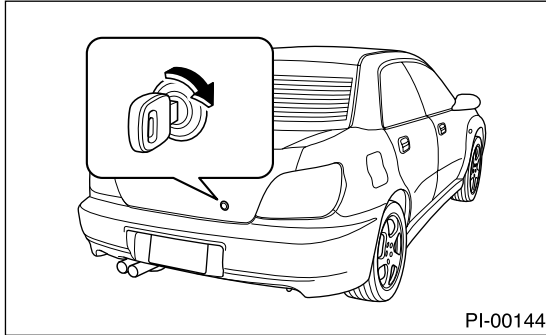

- 4) Check the trunk lid and glove box do not open using valet key.
- 5) Set the trunk lid release lever to the cancel position, and check that the trunk lid can only be opened with the key.

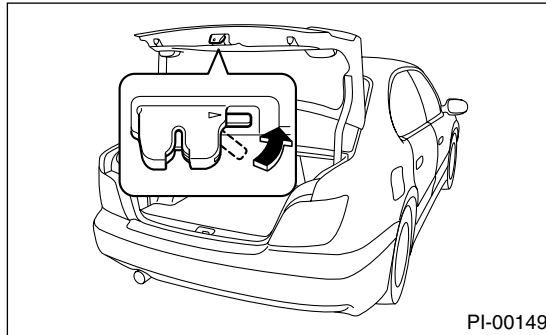

8. CHECK THE REAR GATE FOR LOCK/UNLOCK AND OPEN/CLOSE OPERATIONS

- 1) Open and close the rear gate several times for smooth movement.
- 2) Operate the rear gate lever to check that the rear gate is locked and unlocked normally.
 - (1) Remove the blind cover inside the rear gate.

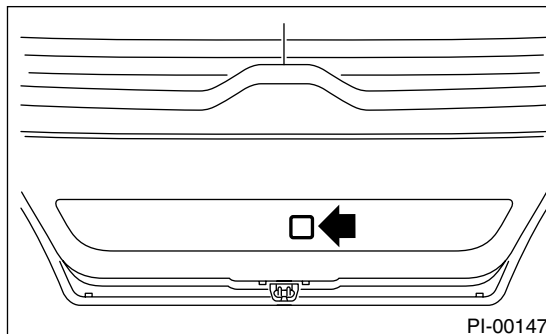

- (2) Check that the rear gate is locked correctly when lever is operated using a finger.

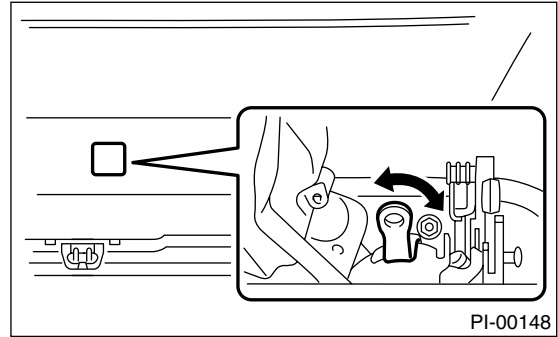

9. OPERATION CHECK OF TRUNK LID RELEASE HANDLE

- 1) Use a flat-tip screwdriver. Slide the screwdriver blade from the slit aperture of the lock assembly fully to the end until you hear a click. This places the latch in the locked position.

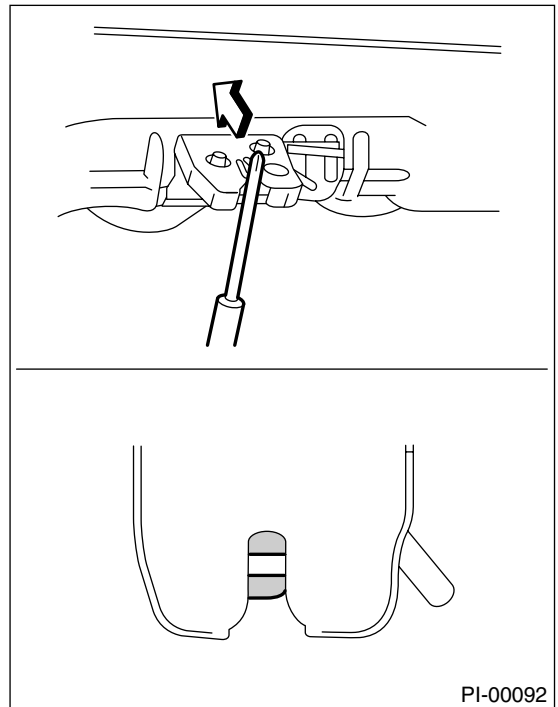

PRE-DELIVERY INSPECTION

PRE-DELIVERY INSPECTION

2) Move the release handle from outside the vehicle in the direction of the arrow to check if the latch is released.

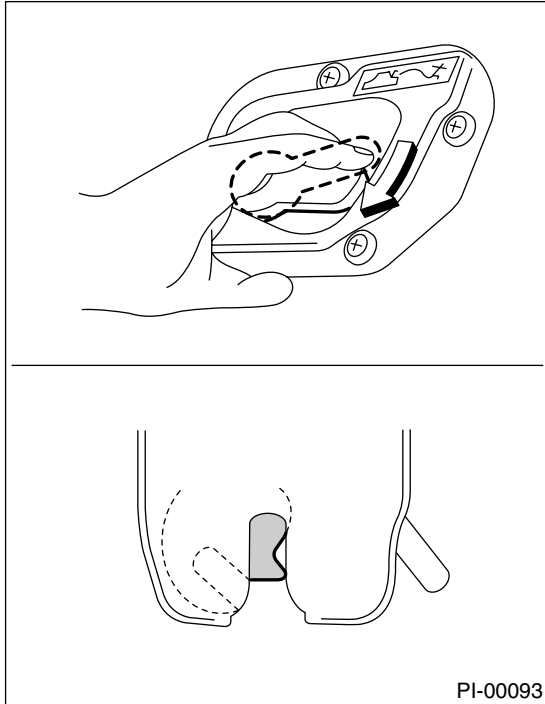

10. OPERATION CHECK OF FUEL LID OPENER LOCK RELEASE LEVER

Operate the fuel lid opener and verify that the fuel lid opens normally. Check that the filler cap is securely closed.

11. ACCESSORY CHECK

Check that the following accessories are provided in the luggage compartment or cargo area.

- Owner's manual
- Warranty booklet
- Service booklet
- Spare key
- Jack
- Tool set
- Spare tire

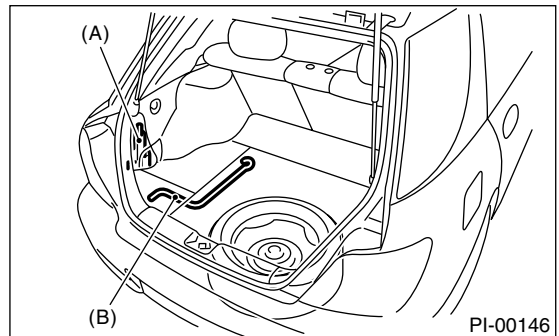
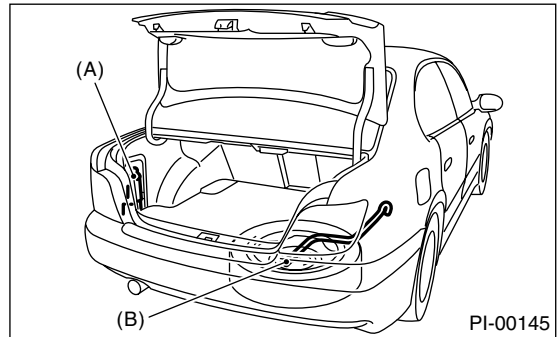

- (A) Jack
- (B) Jack handle

12. OPERATION CHECK OF HOOD LOCK RELEASE SYSTEM

Operate the hood release knob (A) and check that the hood is unlocked normally.

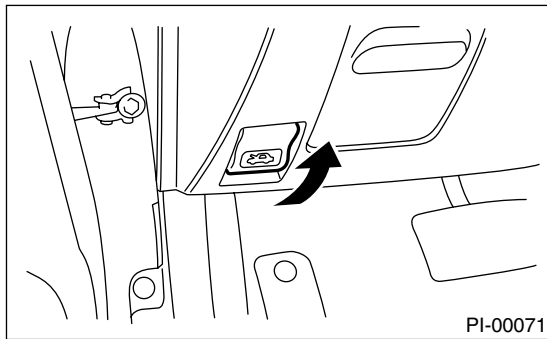

Operate the lever (A) and check that the hood is opened normally. Then support the hood with hood stay.

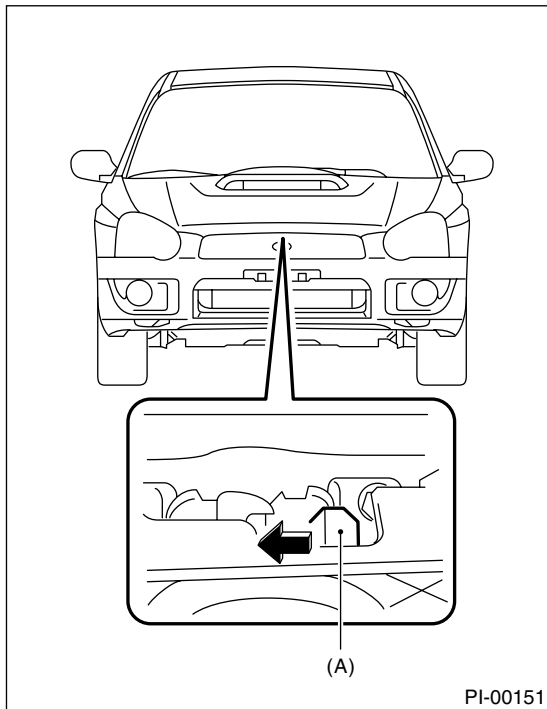

13. BATTERY

Check the battery terminals to make sure that no rust or corrosions due to fluid leaks are found. Check that the battery caps are securely tightened.

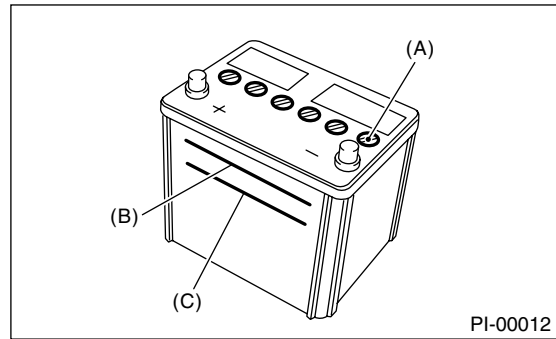

- (A) Cap
- (B) Upper level
- (C) Lower level

14. BRAKE FLUID

Check the brake fluid amount. If the amount is insufficient, carry out a brake line test to identify brake fluid leaks and check the brake operation. After that, refill the brake fluid tank with the specified type of fluid.

15. ENGINE OIL

Check the engine oil amount. If the amount is insufficient, check that no leaks are found. Then, add the necessary amount of the specified engine oil.

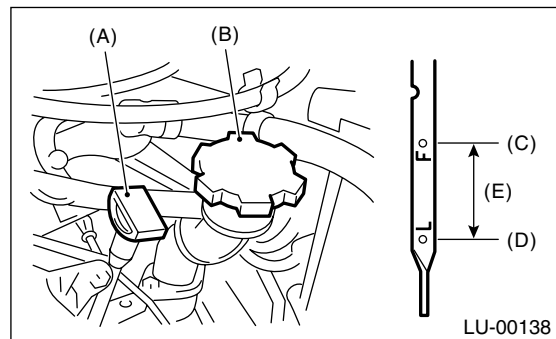

- (A) Oil level gauge
- (B) Engine oil filler cap
- (C) Upper level
- (D) Lower level
- (E) Approx. 1.0 ℓ (1.1 US qt, 0.9 Imp qt)

PRE-DELIVERY INSPECTION

PRE-DELIVERY INSPECTION

16. TRANSMISSION FLUID

Check the transmission fluid amount. If the amount is insufficient, check that no leaks are found. Then, add the necessary amount of the specified fluid.

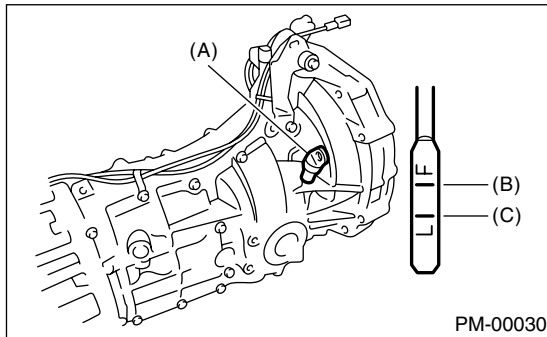

- (A) Oil level gauge
- (B) Upper level
- (C) Lower level

19. CLUTCH FLUID

Check the clutch fluid amount. If the amount is insufficient, check that no leaks are found. Then, add the necessary amount of the specified fluid.

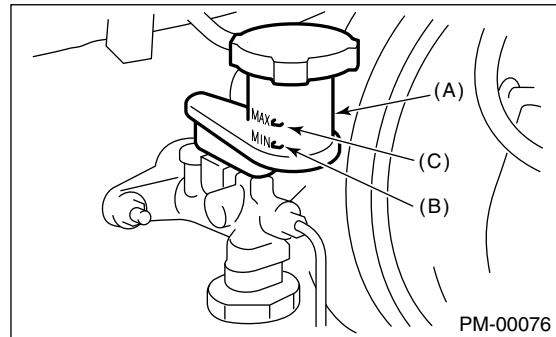

- (A) Reservoir tank
- (B) MIN level
- (C) MAX level

17. AT FRONT DIFFERENTIAL OIL

Check the AT front differential oil amount. If the amount is insufficient, check that no leaks are found. Then, add the necessary amount of the specified AT front differential oil.

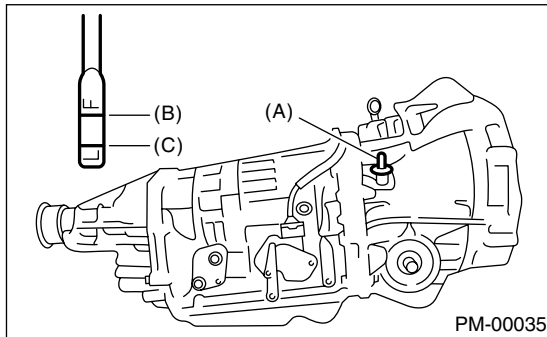

- (A) Oil level gauge
- (B) Upper level
- (C) Lower level

20. WINDOW WASHER FLUID

Check the window washer fluid amount. If the amount is insufficient, check that no leaks are found. Then, add the necessary amount of washer fluid commercially available.

21. HOOD LATCH CHECK

Retract the hood stay and close the hood. Check that the hood is securely latched.

22. KEYLESS ENTRY SYSTEM

Check the keyless entry system operations as follows:

- Fully open all the door windows.
- Remove the key from the ignition switch and close all the doors including rear gate.
- Press the "LOCK/ARM" button on the transmitter momentarily once and check if all the doors are locked, the buzzer chirps once, and the hazard light flashes once.

18. COOLANT

Check the coolant amount on the reservoir. If the amount is insufficient, check that no leaks are found. Then, add the necessary amount of coolant with the specified concentration.

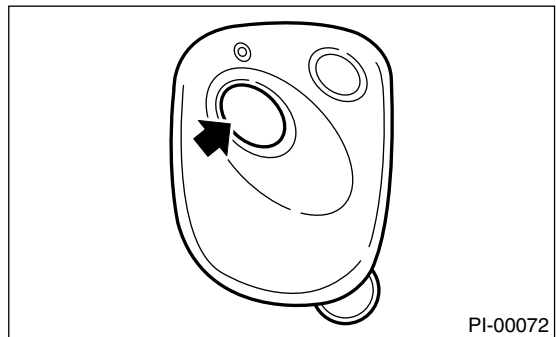

PI-00072

- Press the “UNLOCK/DISARM” button on the transmitter momentarily once and check if the driver’s door is unlocked, the buzzer chirps twice, and the hazard light flashes twice.

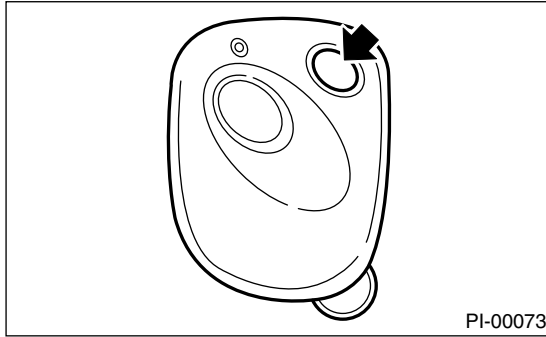

- Press the “UNLOCK/DISARM” button on the transmitter momentarily once again within five seconds and check if all the doors including the rear gate on wagon are unlocked.
- Press the “LOCK/ARM” button on the transmitter a little bit of time (approx. 2 sec.) and check if a panicking condition occurs; the horn sounds continuously. Also, check if that condition lasts for 30 seconds or until any button of the transmitter is pressed.
- Press the “LOCK/ARM” button on the transmitter momentarily once with one of the doors including the rear gate open and check if the buzzer chirps five times to warn of a door ajar. Then, bring all the doors including the rear gate in closed condition and check if all the doors are locked, the buzzer chirps once, and the hazard light flashes once.
- Press the “LOCK” side of the power door locking switch with any one of the doors including the rear gate open. Check the buzzer chirps five times to warn door ajar. Then, bring all the doors including the rear gate in the closed condition and check if all the doors are locked, the buzzer chirps once, and the hazard light flashes once.

- Driver’s seat

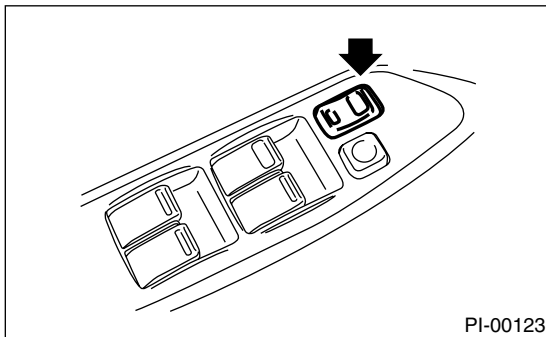

- Passenger’s seat

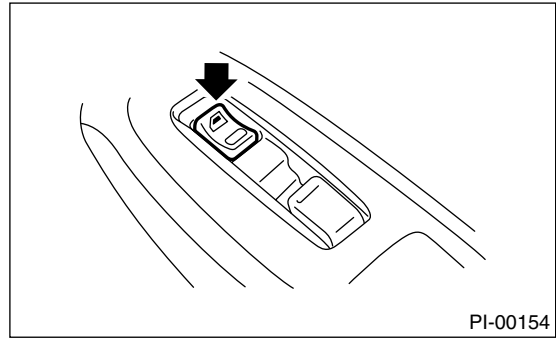

Check selecting audible signal operation.

- Using the buzzer, the system will give you an audible signal when the doors lock and unlock. If desired, you may turn the audible signal off. To turn the audible signal off, carry out the unlocking procedure of keyless entry system, then simultaneously depress LOCK/ARM and UNLOCK/DISARM buttons for more than two seconds. The buzzer will sound twice, and hazard light will flash twice to inform you that the audible signal has been turned off. To turn the audible signal on, carry out the unlocking procedure of keyless entry system, then simultaneously depress LOCK/ARM and UNLOCK/DISARM buttons for more than two seconds. The buzzer will sound once and hazard light will flash once to inform you that the audible signal has been turned on.

23.SECURITY SYSTEM

Check the security system operations as follows:

- Fully open all the door windows.
- Remove the key from the ignition switch and close all the doors including rear gate.
- Press the “LOCK/ARM” button on the transmitter momentarily once and check if all the doors are locked, the buzzer chirps once, the hazard lights flash once and the security indicator light flashes slowly to ensure that the security system has been brought into the arming state.

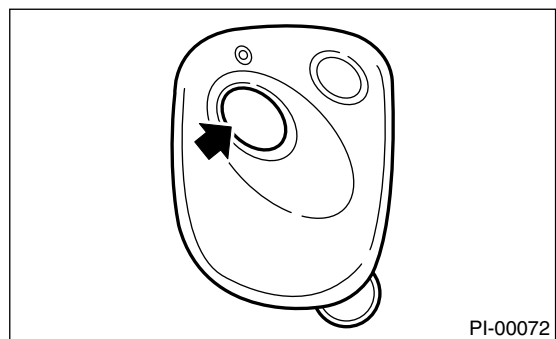

PRE-DELIVERY INSPECTION

PRE-DELIVERY INSPECTION

- Press the “UNLOCK/DISARM” button on the transmitter momentarily once and check if the driver’s door is unlocked, the buzzer chirps twice, the hazard light flash twice, the dome light illuminates and the security indicator light goes off to ensure that the system has been brought into the disarming state.

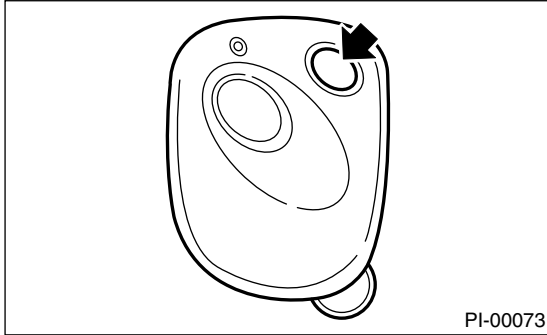

- Press the “UNLOCK/DISARM” button on the transmitter momentarily once again within five seconds and check if all the doors including the rear gate on wagon are unlocked.
- Press the “LOCK/ARM” button on the transmitter a little bit of time (approx. 2 sec.) and check if a panicking condition occurs; the horn sounds continuously, the hazard lights flash and the security indicator light flashes rapidly. Also, check if that condition lasts for 30 seconds or until any button of the transmitter is pressed.
- Press the “LOCK/ARM” button on the transmitter momentarily once with one of the doors including the rear gate open and check if the buzzer chirps five times to warn of a door ajar. Then, bring all the doors including the rear gate in closed condition and check if the arming condition is brought about; all the doors are locked, the buzzer chirps once and the hazard lights flash once.
- Press the “LOCK” side of the power door locking switch with any one of the doors including the rear gate open. Check the buzzer chirps five times to warn door ajar. Then, bring all the doors including the rear gate in the closed condition and check if all the doors are locked, the buzzer chirps once and the hazard lights flash once to ensure that the security system has been brought into the arming state.

- Driver’s seat

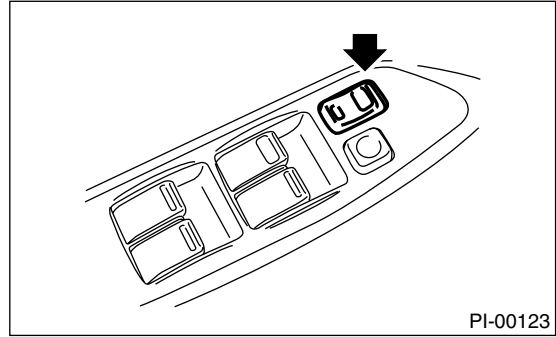

- Passenger’s seat

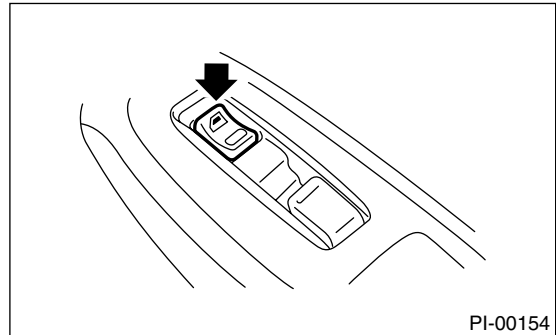

- Unlock a door using the inner lock knob or the key and open the door while the security system is in the arming state. Check to ensure that the alarming condition occurs, i.e. the horn sounds continuously, the hazard lights flash and security indicator light flashes rapidly, and that it lasts for 30 seconds or until the “UNLOCK/DISARM” button on the transmitter is pressed. Also, check to ensure that turning the ignition key to the “START” position in the arming state does not cause the starter motor to turn, thus the engine being prevented from starting.
- Apply a shock to the vehicle body with the security system in arming state, and check to ensure that the alarming condition occurs.
- Troubleshoot the security system if any one of the above-mentioned checks does not meet the requirements.

24. SEAT

Check that each seat provides full functionality in sliding and reclining. Check all available functions of the rear seat such as a trunk-through center arm rest.

25. SEAT BELT

Pull out the seat belt and then release it. Check that the belt webbing retracts smoothly.

26. WHEEL ALIGNMENT

Check the wheel alignments. <Ref. to FS-6, Wheel Alignment.> and <Ref. to RS-8, Wheel Alignment.>

27. TEST MODE CONNECTOR

Turn the ignition switch to ON and check that the malfunction indicator light starts blinking. If the light blinks, return the ignition key to LOCK and disconnect the test mode connector. Then, turn the ignition key to ON again. If the malfunction indicator light blinks at that time in spite of the disconnected test mode connector, carry out an engine diagnosis.

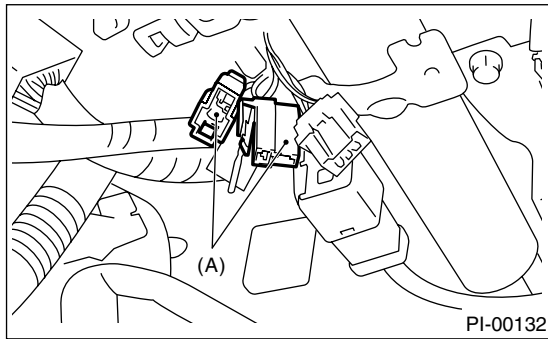

(A) Test mode connector (Green)

28. STARTING CONDITION

Start the engine and check that the engine starts smoothly. If any battery voltage problems are found, recharge or replace the battery. If any abnormal noises are observed, immediately stop the engine and check and repair the necessary components.

29. EXHAUST SYSTEM

Listen to the exhaust noise to see if no abnormal noises are observed.

30. INDICATOR LIGHT

Check that all the indicator lights are off.

31. CLOCK

Check the clock for normal operations and enough accuracy.

32. RADIO

Check the radio for full functionality and normal noise level. Also check the CD unit operations.

33. FRONT ACCESSORY POWER SUPPLY SOCKET

Check the front accessory power supply socket operations.

34. LIGHTING SYSTEM

- Check the headlight operations.
- Check the stop light operations.
- Check the other lights for normal operations.

35. WINDOW WASHER

Check that the window washer system injects washer fluid to the specified area of windshield shown in the figure.

Front injection position:

A: 257 mm (10.12 in)

B: 512 mm (20.16 in)

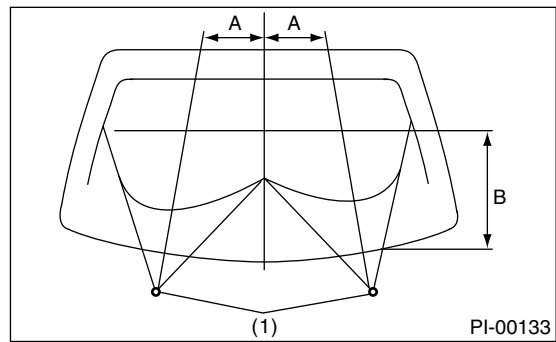

(1) Nozzle

Rear injection position:

A: 39 mm (2.36 in)

B: 72°

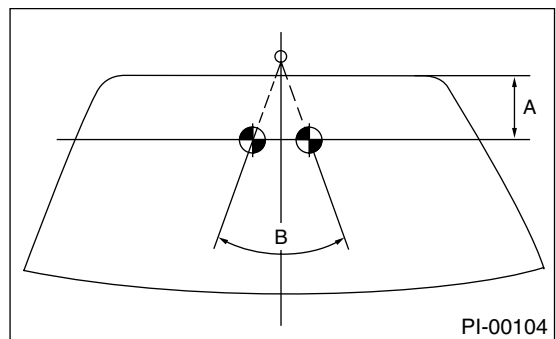

36. WIPER

Check the front and rear wipers for normal operations.

PRE-DELIVERY INSPECTION

PRE-DELIVERY INSPECTION

37. POWER WINDOW OPERATION CHECK

Manipulate the power window switches one by one to check that each of the power windows goes up and down with no abnormal noises.

38. BRAKE TEST

Check the foot brake for normal operations.

39. PARKING BRAKE

Check the parking brake for normal operations.

40. AT SHIFT CONTROL

Set the AT select lever to each gear position while checking that the demanded gear position is correctly attained.

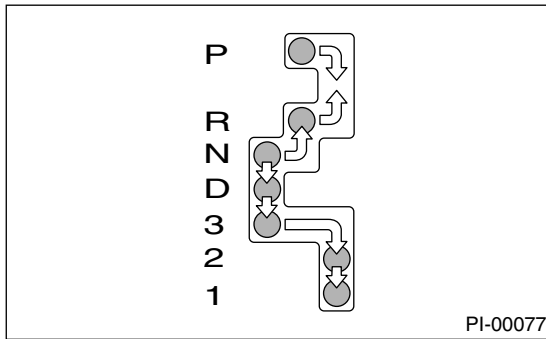

Selector Position	Gear Position			
	1st	2nd	3rd	4th
D	Yes	Yes	Yes	Yes
3	Yes	Yes	Yes	—
2	—	Yes	—	—
1	Yes	—	—	—

41. HEATER & VENTILATION

Operate the heater and ventilation system to check for normal outlet selection, air inlet selection, air-flow and heating capacity.

42. AIR CONDITIONER

Operate the air conditioner. Check that the A/C compressor operates normally and enough cooling is provided.

43. CRUISE CONTROL

Operate the cruise control system. Check that the system is activated and deactivated correctly.

44. ATF LEVEL

Check that the ATF level is normal. If insufficient, check that no leaks are found. Then add the necessary amount of the specified ATF.

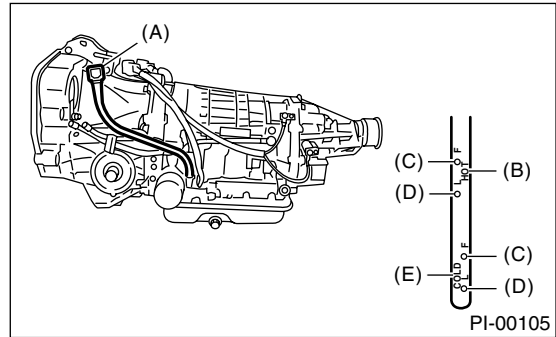

- (A) Level gauge
- (B) Check position when "HOT"
- (C) Upper level
- (D) Lower level
- (E) Check position when "COLD"

45. POWER STEERING FLUID LEVEL

Check that the power steering fluid level is normal. If insufficient, check that no leaks are found. Then add the necessary amount of the specified power steering fluid.

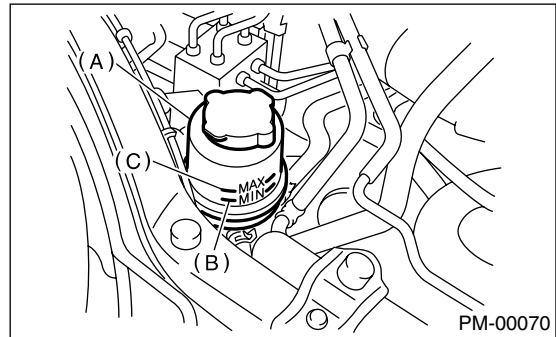

- (A) Reservoir tank
- (B) MIN level
- (C) MAX level

46. FLUID LEAK CHECK

Check the entire areas of the vehicle for any trace of coolant/oil/fluid leaks.

47. WATER LEAK TEST

Spray the vehicle with water and check that no water enters the passenger compartment.

- Before performing the water leakage test, remove anything that may obstruct the operation or which must be kept dry.
- Close all windows completely, and then close all doors tightly. Close the hood and trunk lid before starting the test.
- Connect a hose to a tap, and spray water on the vehicle. The rate of water discharge must be approx. 20 — 25 ℓ (5.3 — 6.6 US gal, 4.4 — 5.5 Imp gal) per minute.

When spraying water on areas adjacent to the floor and wheel house, increase the pressure. When directing water on areas other than the floor portion and wheel house, decrease the pressure. But the force of water must be made strong occasionally by pressing the end of the hose.

NOTE:

Be sure to keep the hose at least 10 cm (3.9 in) from the vehicle.

Check the following areas:

- Front window and body framework mating portion
- Door mating portions
- Glass mating portions
- Rear quarter window mating portions
- Rear window and body framework mating portion
- Around roof drips

If any dampness in the compartment is discovered after the water has been applied, carefully check all areas that may have possibly contributed to the leak.

48. APPEARANCE CHECK 2

1) When vehicle body is covered with protective film, peel it off.

NOTE:

- Use of steam eases peeling off the wrap guard.
- When performing on the vehicles left for a long time, or during low temperature period, sprinkle some water heated to 50 — 60°C (122 — 140°F) over the vehicle to raise its surface temperature before peeling off the wrap guard.

Do not use the water heated to over 60°C (140°F).

- If the adhesive remains on the coated surface, rub the portion with a flannel rag, etc. soaked with a coat of coating wax or a solvent, such as oil benzene and IPA, and then wipe it off.
- Avoid adhesion of the solvent to resin or rubber components. Do not use coating wax or a solvent while the component surface temperature is high due to hot weather, etc.

- If the coated surface is swollen out due to seams or moisture, expose the vehicle to the sun light for a few hours. Otherwise, heat the portion with seams or moisture using a dryer, etc.

- Dispose of the peeled wrap guard as burnable industrial garbage.

2) Check the whole vehicle body for stains, flaking, damage caused by transportation, rust, dirt, cracks, or blistering.

NOTE:

- It is better to determine an inspection pattern in order to avoid missing an area, since the total inspection area is wide.

• It is desirable not to make corrections to the body paint unless absolutely needed. However, if any corrections are required to remove scratches or rust, the area to be corrected must be limited as much as possible. Re-painting and spray painting must be avoided whenever possible.

3) Carefully check each window glass for scratches. Slight damage may be removed by polishing with cerium oxide. (Half-fill a cup with cerium oxide, and add warm water to it. Then agitate the content until it turn to wax. Apply this wax to a soft cloth, and polish the glass.)

4) Check each portion of the vehicle body and underside components for the formation of rust. If rust is discovered, remove it with #80 — #180 emery paper, and treat the surface with rust preventive. After this treatment is completed, flush the portion thoroughly, and prepare the surface for repair painting.

5) Check each portion of the body and all of the chrome parts for deformation or distortion. Also check each lamp lens for cracks.

PRE-DELIVERY INSPECTION

PRE-DELIVERY INSPECTION
