

FUEL TANK SENSOR CONTROL VALVE

EMISSION CONTROL (AUX. EMISSION CONTROL DEVICES)

10. Fuel Tank Sensor Control Valve

A: REMOVAL

WARNING:

- Place “NO FIRE” signs near the working area.
- Be careful not to spill fuel.

- 1) Remove the fuel tank. <Ref. to FU(STi)-46, REMOVAL, Fuel Tank.>
- 2) Remove the protector cover.

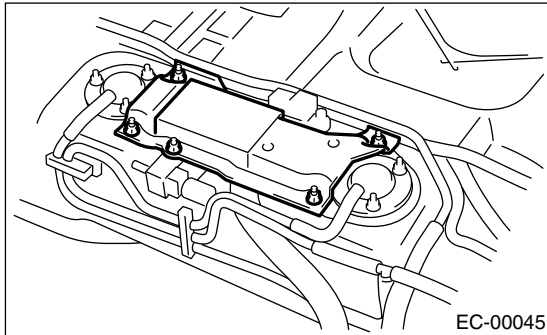

- 3) Disconnect the connector from fuel tank sensor control valve.
- 4) Disconnect hose and remove fuel tank sensor control valve.

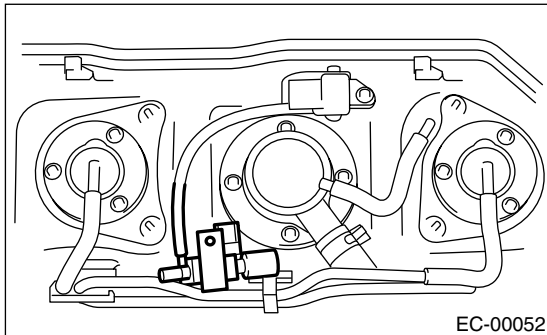

B: INSTALLATION

Install in the reverse order of removal.

Tightening torque:

T1: 7.4 N·m (0.75 kgf-m, 5.4 ft-lb)

T2: 4.4 N·m (0.45 kgf-m, 3.3 ft-lb)

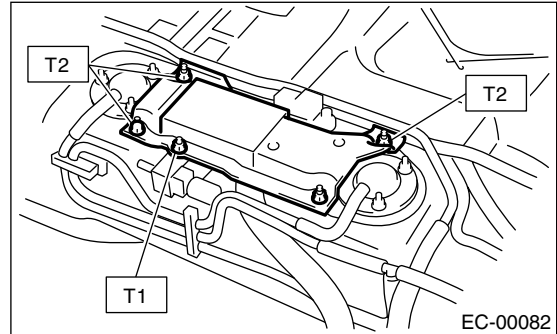

C: INSPECTION

Make sure the hoses are not cracked or loose.