

14. Timing Belt Cover

A: REMOVAL

- 1) Remove the V-belt. <Ref. to ME(STi)-41, REMOVAL, V-belt.>
- 2) Remove the crankshaft pulley. <Ref. to ME(STi)-44, REMOVAL, Crankshaft Pulley.>
- 3) Remove the timing belt cover (LH) (A).
- 4) Remove the timing belt cover (RH) (B).
- 5) Remove the front timing belt cover (C).

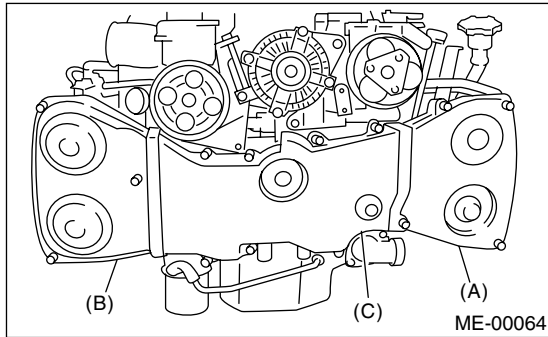

B: INSTALLATION

- 1) Install the front timing belt cover (C).

Tightening torque:

5 N·m (0.5 kgf-m, 3.6 ft-lb)

- 2) Install the timing belt cover (RH) (B).

Tightening torque:

5 N·m (0.5 kgf-m, 3.6 ft-lb)

- 3) Install the timing belt cover (LH) (A).

Tightening torque:

5 N·m (0.5 kgf-m, 3.6 ft-lb)

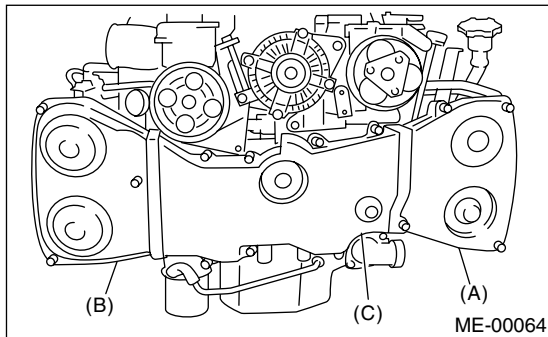

- 4) Install the crankshaft pulley. <Ref. to ME(STi)-44, INSTALLATION, Crankshaft Pulley.>
- 5) Install the V-belt. <Ref. to ME(STi)-41, INSTALLATION, V-belt.>

C: INSPECTION

Make sure the cover is not damaged.