

17. Crankshaft Sprocket

A: REMOVAL

- 1) Remove the V-belt. <Ref. to ME(STi)-41, REMOVAL, V-belt.>
- 2) Remove the crankshaft pulley. <Ref. to ME(STi)-44, REMOVAL, Crankshaft Pulley.>
- 3) Remove the timing belt cover. <Ref. to ME(STi)-45, REMOVAL, Timing Belt Cover.>
- 4) Remove the timing belt assembly. <Ref. to ME(STi)-46, REMOVAL, Timing Belt Assembly.>
- 5) Remove the camshaft sprocket. <Ref. to ME(STi)-54, REMOVAL, Camshaft Sprocket.>
- 6) Remove the crankshaft sprocket.

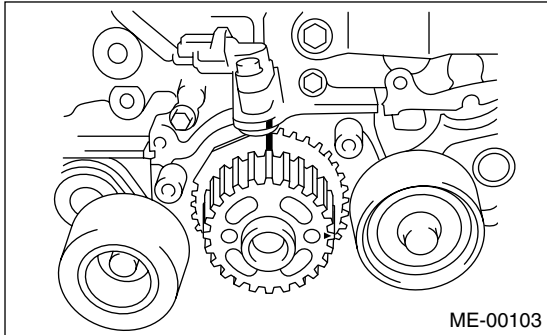

B: INSTALLATION

- 1) Install the crankshaft sprocket.

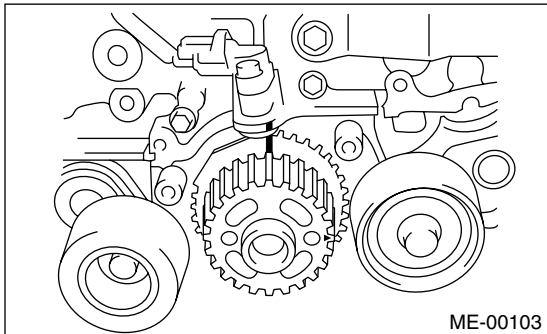

- 2) Install the camshaft sprocket. <Ref. to ME(STi)-54, INSTALLATION, Camshaft Sprocket.>
- 3) Install the timing belt assembly. <Ref. to ME(STi)-48, INSTALLATION, Timing Belt Assembly.>
- 4) Install the timing belt cover. <Ref. to ME(STi)-45, INSTALLATION, Timing Belt Cover.>
- 5) Install the crankshaft pulley. <Ref. to ME(STi)-44, INSTALLATION, Crankshaft Pulley.>
- 6) Install the V-belt. <Ref. to ME(STi)-41, INSTALLATION, V-belt.>

C: INSPECTION

- 1) Check the sprocket teeth for abnormal wear and scratches.
- 2) Make sure there is no free play between sprocket and key.
- 3) Check the crankshaft sprocket notch used for sensor for damage and contamination of foreign matter.