

TORQUE CONVERTER CLUTCH ASSEMBLY

AUTOMATIC TRANSMISSION

25. Torque Converter Clutch Assembly

A: REMOVAL

- 1) Remove the transmission assembly from the vehicle. <Ref. to 4AT-36, REMOVAL, Automatic Transmission Assembly.>
- 2) Extract the torque converter clutch and oil pump shaft horizontally.

NOTE:

Be careful not to scratch the bushing inside the oil pump shaft.

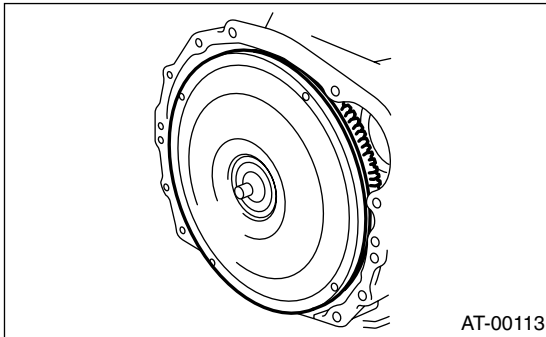

- 3) Remove the input shaft.

NOTE:

When the torque converter clutch assembly is removed, the input shaft will come out.

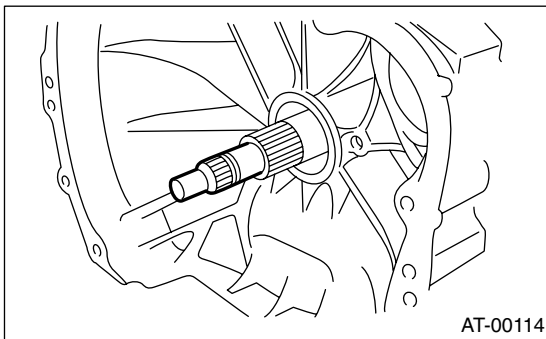

- 4) Remove the oil pump shaft from torque converter clutch as necessary.

B: INSTALLATION

- 1) Install the oil pump shaft to torque converter clutch if it is removed.
- 2) Install the oil pump shaft to the torque converter clutch, and then check the clip fits securely in its groove.
- 3) Insert the input shaft while turning lightly by hand.

Normal protrusion A:

50 — 55 mm (1.97 — 2.17 in)

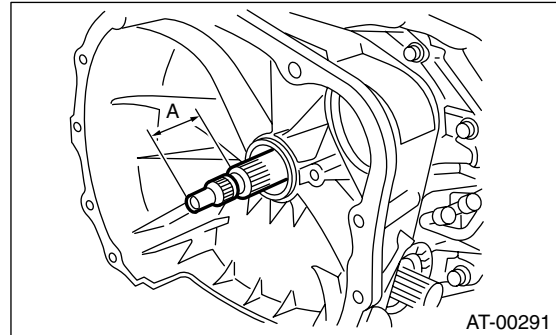

- 4) Holding the torque converter clutch assembly by hand, carefully install it to the torque converter clutch case. Be careful not to damage the bushing. Also avoid undue contact between the oil pump shaft bushing and stator shaft portion of the oil pump cover.
- 5) Rotate the shaft lightly by hand to engage the splines securely.

Dimension A:

2.7 — 2.9 mm (0.106 — 0.114 in)

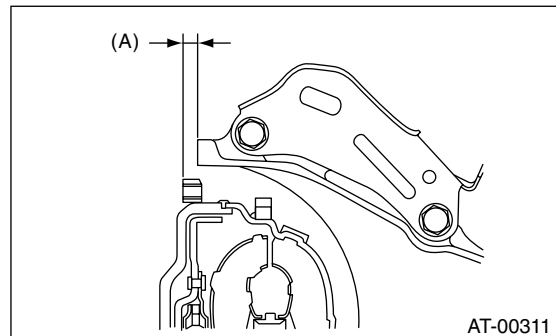

(A) Dimension A

- 6) Install the transmission assembly to vehicle. <Ref. to 4AT-38, INSTALLATION, Automatic Transmission Assembly.>

C: INSPECTION

Make sure the ring gear is not damaged and that the protrusion on the edge of the torque converter clutch is not deformed or otherwise damaged.