

FRONT DIFFERENTIAL ASSEMBLY

MANUAL TRANSMISSION AND DIFFERENTIAL

23. Front Differential Assembly

A: REMOVAL

- 1) Remove the manual transmission assembly. <Ref. to 6MT-35, REMOVAL, Manual Transmission Assembly.>
- 2) Prepare the transmission for overhaul. <Ref. to 6MT-40, Preparation for Overhaul.>
- 3) Remove the oil pipe, neutral position switch, back-up light switch and harness. <Ref. to 6MT-42, REMOVAL, Oil Pipe.>, <Ref. to 6MT-45, REMOVAL, Neutral Position Switch.>, <Ref. to 6MT-43, REMOVAL, Back-up Light Switch.>
- 4) Remove the extension case. <Ref. to 6MT-47, REMOVAL, Extension Case.>
- 5) Remove the transfer driven gear. <Ref. to 6MT-58, REMOVAL, Transfer Driven Gear.>
- 6) Remove the center differential. <Ref. to 6MT-60, REMOVAL, Center Differential.>
- 7) Remove the oil pump. <Ref. to 6MT-61, REMOVAL, Oil Pump.>
- 8) Remove the transmission case. <Ref. to 6MT-65, REMOVAL, Transmission Case.>
- 9) Remove each gear assembly. <Ref. to 6MT-70, REMOVAL, Main Shaft Assembly.>
- 10) Remove the drive pinion shaft assembly. <Ref. to 6MT-97, REMOVAL, Drive Pinion Shaft Assembly.>
- 11) Remove the lock plates on both side.

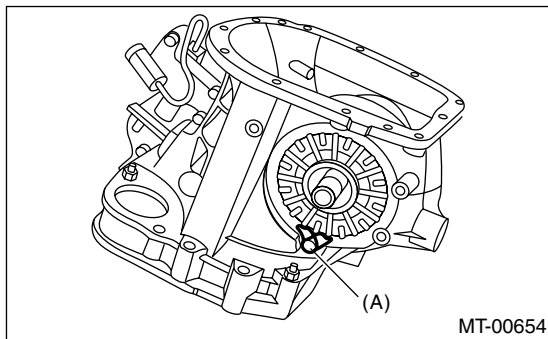

(A) Lock plate

- 12) Wrap the spline part of axle shaft around with vinyl tape.

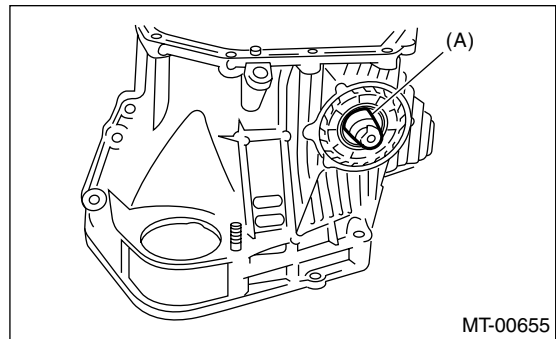

(A) Vinyl tape

- 13) Using the ST, remove the axle shaft.
ST1 499247300 INSTALLER
ST2 499095500 REMOVER ASSY

NOTE:

- Do not reuse the circlip.
- Mark to identify the right and left axle shaft.

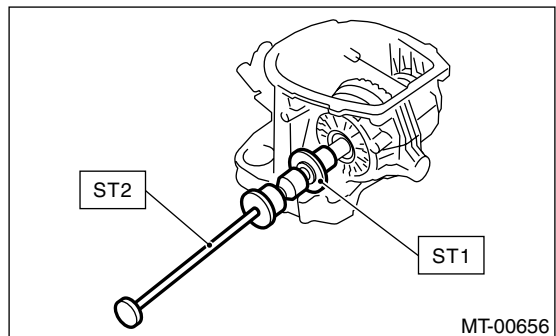

FRONT DIFFERENTIAL ASSEMBLY

MANUAL TRANSMISSION AND DIFFERENTIAL

14) Using the ST, remove the differential side retainer on both sides.

ST1 499787000 WRENCH ASSY (RIGHT SIDE)

ST2 18630AA000 WRENCH ASSY (LEFT SIDE)

NOTE:

Be careful not to damage the part of clutch case where the retainer is to be installed.

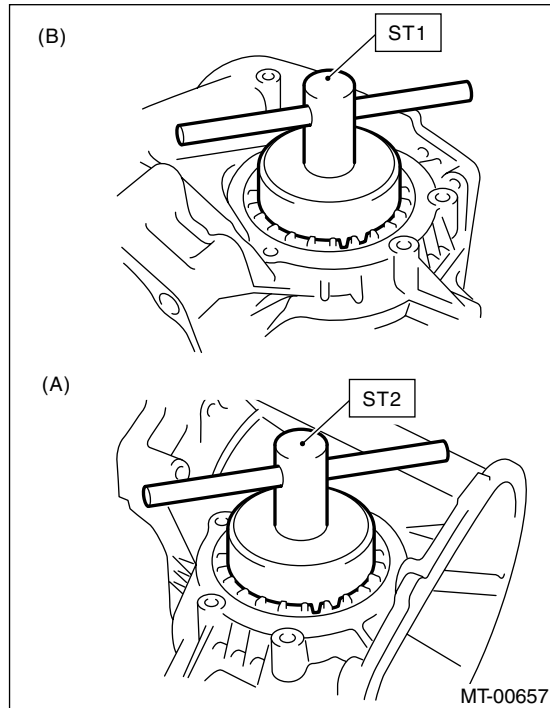

(A) Left side
(B) Right side

15) Remove the front differential.

B: INSTALLATION

1) Install the differential assembly into clutch housing.

2) Apply oil to the threaded portion part of side retainer.

3) Remove the O-ring from side retainer of both sides.

4) Using the ST, install the differential side retainer to both sides.

ST1 499787000 WRENCH ASSY (RIGHT SIDE)

ST2 18630AA000 WRENCH ASSY (LEFT SIDE)

NOTE:

Be careful not to damage the oil seal.

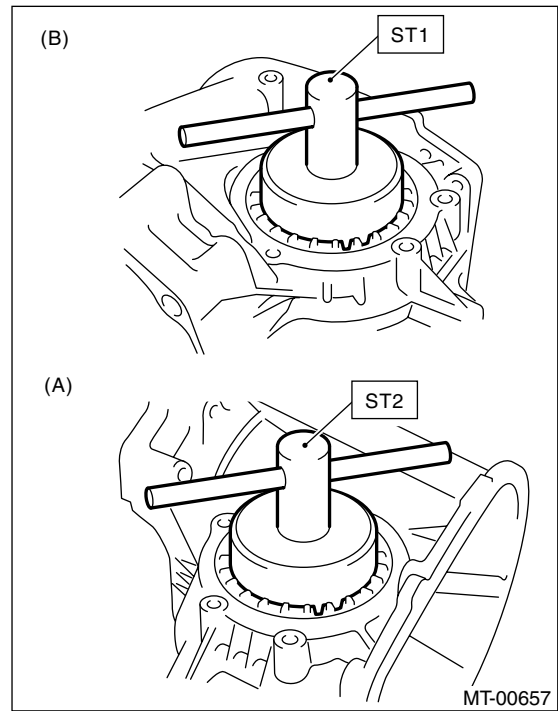

(A) Left side
(B) Right side

5) Install the axle shaft.

NOTE:

- Replace the circlip with a new one.
- Be careful not to confuse right and left axle shaft.
- Wrap vinyl tape around the spline part of axle shaft.

6) Check and adjust the hypoid gear backlash. <Ref. to 6MT-107, HYPOID GEAR BACKLASH, INSPECTION, Front Differential Assembly.>

7) Check and adjust the tooth contact. <Ref. to 6MT-101, ADJUSTMENT, Drive Pinion Shaft Assembly.>

8) Mark an engagement point on the right and left side retainer and clutch housing.

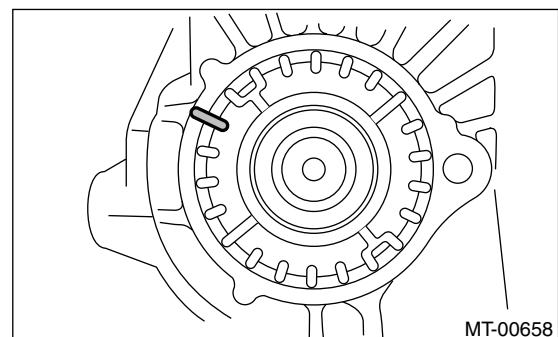

9) Remove the differential side retainer from both sides.

FRONT DIFFERENTIAL ASSEMBLY

MANUAL TRANSMISSION AND DIFFERENTIAL

NOTE:

Note the rotating number of time till removal, when removing the side retainer.

10) Install a new O-ring to side retainer of both sides.

11) Install the differential side retainer to both sides.

NOTE:

Install the side retainer by screwing in the same rotating number of time till removal, and then align the mark.

12) Install the lock plate.

Tightening torque:

25 N·m (2.5 kgf·m, 18.1 ft·lb)

NOTE:

Be careful not to confuse right and left lock plates.

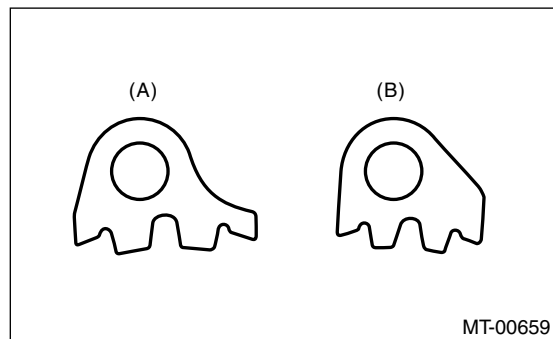

(A) Left

(B) Right

13) Completely remove the remaining gasket from the clutch housing and adapter plate.

14) Apply liquid gasket to the clutch housing.

Liquid gasket:

THREE BOND 1215 (Part No. 004403007)

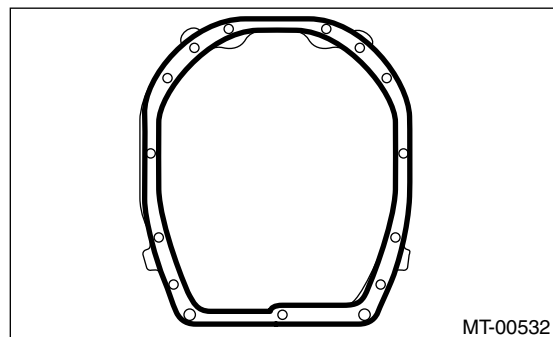

15) Install the drive pinion shaft assembly. <Ref. to 6MT-97, INSTALLATION, Drive Pinion Shaft Assembly.>

16) Install each gear assembly at once. <Ref. to 6MT-71, INSTALLATION, Main Shaft Assembly.>

17) Install the transmission case. <Ref. to 6MT-66, INSTALLATION, Transmission Case.>

18) Install the oil pump. <Ref. to 6MT-62, INSTALLATION, Oil Pump.>

19) Install the center differential. <Ref. to 6MT-60, INSTALLATION, Center Differential.>

20) Install the transfer driven gear. <Ref. to 6MT-58, INSTALLATION, Transfer Driven Gear.>

21) Install the extension case. <Ref. to 6MT-47, INSTALLATION, Extension Case.>

22) Install the oil pipe, neutral position switch, back-up light switch and harness. <Ref. to 6MT-42, INSTALLATION, Oil Pipe.>, <Ref. to 6MT-45, INSTALLATION, Neutral Position Switch.>, <Ref. to 6MT-43, INSTALLATION, Back-up Light Switch.>

23) Install the manual transmission assembly to vehicle. <Ref. to 6MT-37, INSTALLATION, Manual Transmission Assembly.>

C: DISASSEMBLY

1. DIFFERENTIAL CASE

1) Secure the differential assembly on a vise, and then remove the hypoid driven gear.

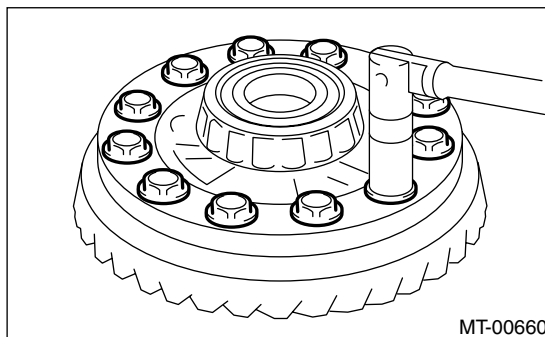

2) Using the ST, remove the hypoid driven gear side bearing.

ST 399527700 PULLER SET

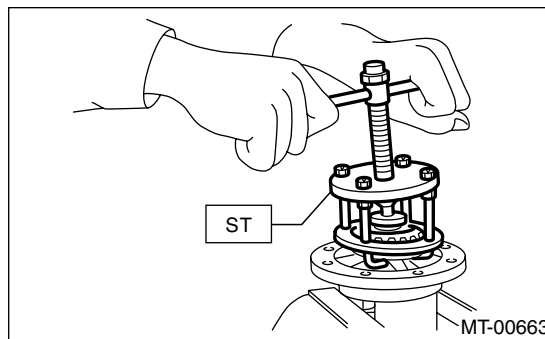

3) Using a screw driver, make clearance of 2 — 3 mm (0.079 — 0.118 in) between the speedometer drive gear and roller bearing.

FRONT DIFFERENTIAL ASSEMBLY

MANUAL TRANSMISSION AND DIFFERENTIAL

NOTE:

Be careful not to damage the differential case.

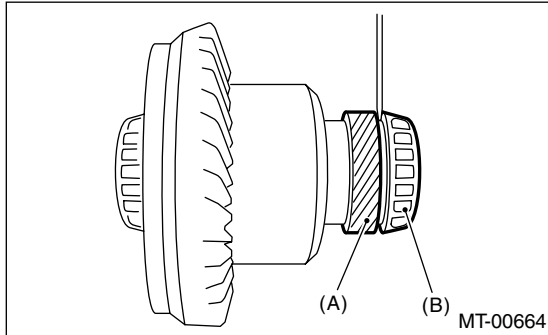

- (A) Speedometer drive gear
- (B) Roller bearing

- 4) Using the ST, remove the roller bearing.
ST 498077000 REMOVER

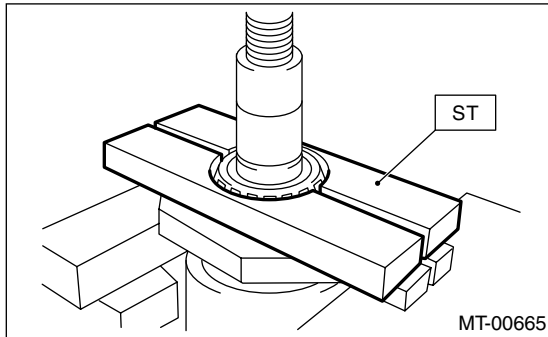

2. SIDE RETAINER

- 1) Remove the O-ring from side retainer.

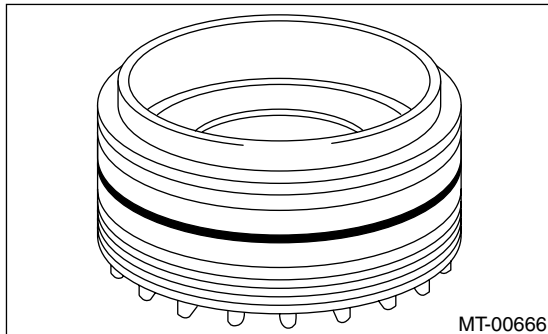

- 2) Remove the oil seal from side retainer.

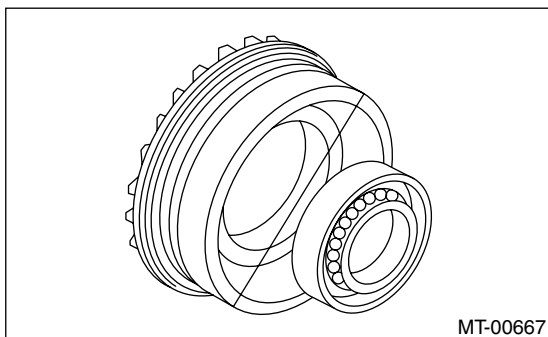

- 3) Remove the claw of ST1, and then install the claw of ST2.

ST1 398527700 PULLER ASSY
ST2 18760AA000 CLAW

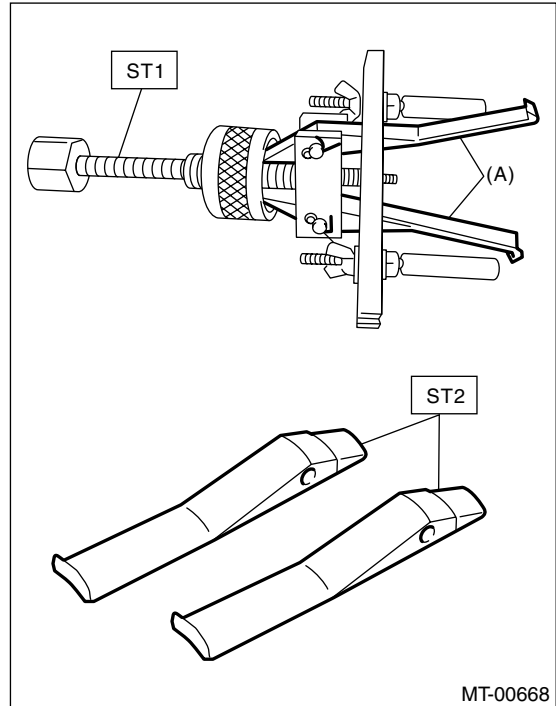

- (A) Claw

- 4) Remove the bearing outer race from side retainer.

ST1 398527700 PULLER ASSY
ST2 18760AA000 CLAW

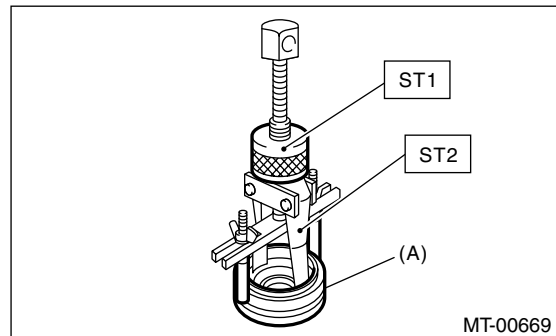

- (A) Side retainer

D: ASSEMBLY

1. DIFFERENTIAL CASE

- 1) Using the ST, install a new speedometer drive gear and right and left side bearing inner race to differential case.

ST1 398437700 INSTALLER
ST2 398497701 SEAT

FRONT DIFFERENTIAL ASSEMBLY

MANUAL TRANSMISSION AND DIFFERENTIAL

CAUTION:

Do not apply pressure in excess of 20 kN (2.0 ton, 2.2 US ton, 2.0 Imp ton).

NOTE:

Always replace the inner race and outer race as a set.

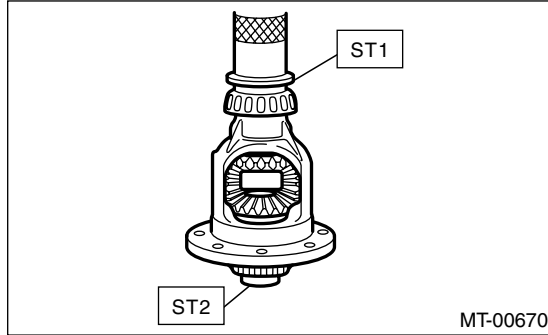

2) Install the hypoid driven gear to differential case.

Tightening torque:

69 N·m (7.0 kgf·m, 50.9 ft·lb)

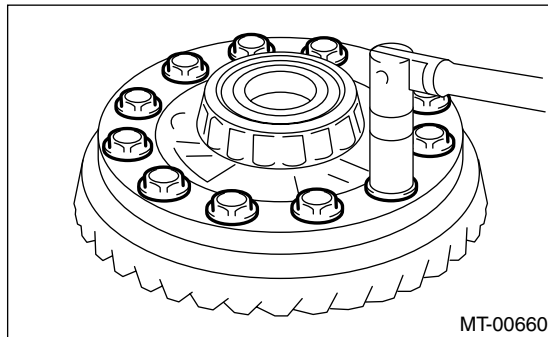

2. SIDE RETAINER

1) Using the ST, install the oil seal.

ST 499797000 OIL SEAL INSTALLER

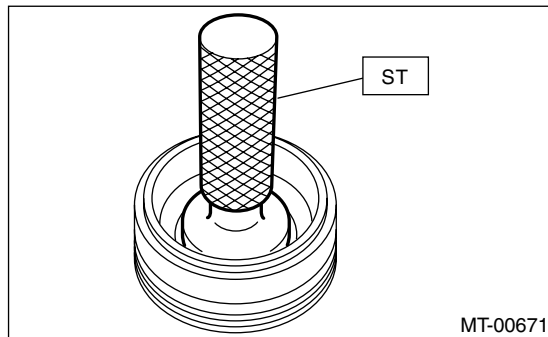

2) Install the bearing outer race to retainer on both sides.

3) Install the O-ring to retainer on both sides.

NOTE:

Be careful not to damage the O-ring.

E: INSPECTION

Repair or replace the front differential in following cases.

- Each gear is damaged, seized, or excessively worn.
- Sliding surface of the differential case is damaged, seized or excessively worn.
- Bearings and bearings part are damaged, rusted or worn.
- Bearings fail to turn smoothly or make abnormal noise when turned.

1. HYPOID GEAR BACKLASH

Check the hypoid gear backlash. If it is not within specifications, adjust it. <Ref. to 6MT-108, HYPOID GEAR BACKLASH, Front Differential Assembly.>

2. TOOTH CONTACT OF HYPOID GEAR

1) Be sure the hypoid gear backlash is within specifications. If it is not within specifications, adjust it. <Ref. to 6MT-108, HYPOID GEAR BACKLASH, Front Differential Assembly.>

2) Apply a uniform thin coat of red lead on both tooth surfaces of three or four teeth of the hypoid driven gear.

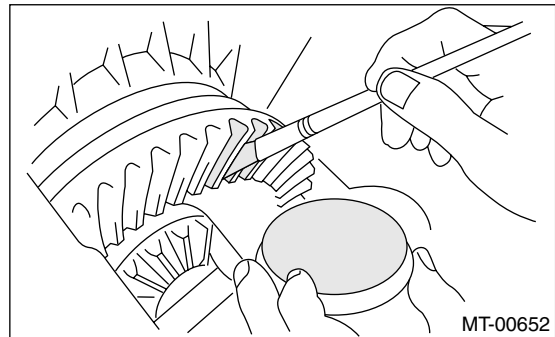

3) Install the drive pinion shaft assembly, and then secure it with four bolts.

NOTE:

Use the old gasket and washer to prevent the mating surface of housing from damaging.

Tightening torque:

50 N·m (5.0 kgf·m, 36.9 ft·lb)

4) Rotate the drive pinion shaft to right and left for several times.

5) Remove the drive pinion shaft assembly, and then check tooth contact. If tooth contact is inaccurate, adjust it. <Ref. to 6MT-101, ADJUSTMENT, Drive Pinion Shaft Assembly.>

FRONT DIFFERENTIAL ASSEMBLY

MANUAL TRANSMISSION AND DIFFERENTIAL

- Correct tooth contact.

NOTE:

Under no load, tooth contacts 50 — 60% from center to toe side (tooth contact shifts to heel side when driving).

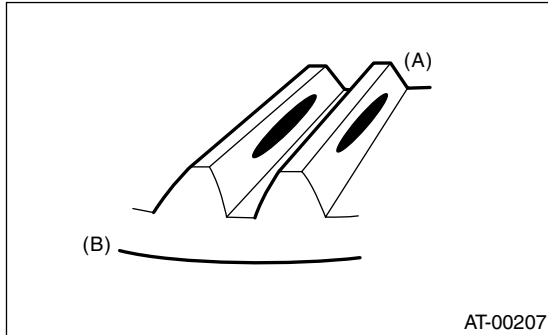

- (A) Toe side
(B) Heel side

F: ADJUSTMENT

1. HYPOID GEAR BACKLASH

- 1) Install the right and left side retainer.

ST1 499787000 WRENCH ASSY (RIGHT SIDE)

ST2 18630AA000 WRENCH ASSY (LEFT SIDE)

NOTE:

Screw in the right side retainer a bit further than left side.

- 2) Install the drive pinion shaft assembly, and then secure it with four bolts.

NOTE:

Use the old gasket and washer to prevent the mating surface of housing from damaging.

Tightening torque:

50 N·m (5.0 kgf·m, 36.9 ft·lb)

- 3) Using the ST, screw in the left side retainer until the drive pinion and hypoid driven gear contacts lightly. Then loosen the right side retainer.

ST1 499787000 WRENCH ASSY (RIGHT SIDE)

ST2 18630AA000 WRENCH ASSY (LEFT SIDE)

- 4) Using the ST, rotate the drive pinion shaft several times.

ST 18631AA000 HANDLE

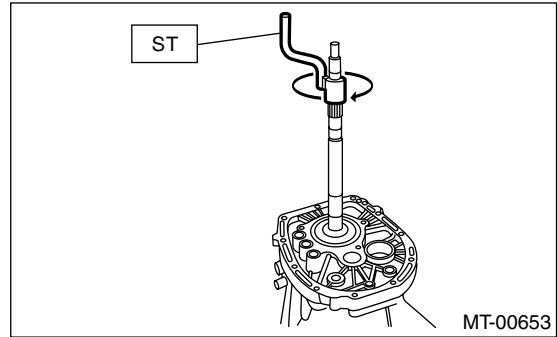

- 5) Repeat step 3) and 4) until the left side retainer can not be rotated. For the right side retainer, screw it in until the inner race and outer race contacts lightly. This condition is "0" backlash.

- 6) Mark an engagement point on the right and left side retainer and clutch housing.

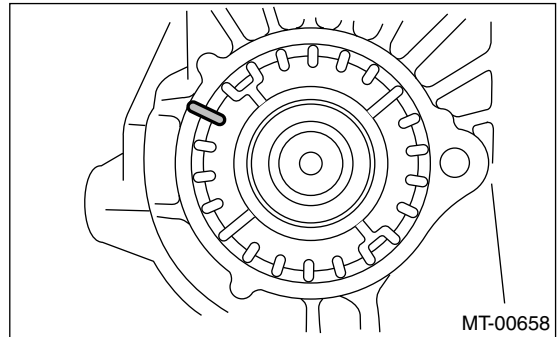

- 7) Return the left side retainer for three teeth, and screw in the right side retainer for three teeth.

- 8) Using the ST, secure the drive pinion shaft.

ST 18621AA000 ADAPTER WRENCH

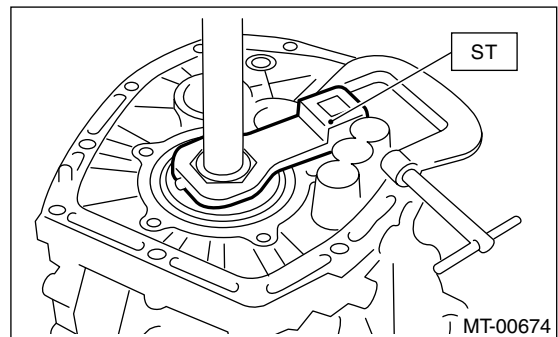

FRONT DIFFERENTIAL ASSEMBLY

MANUAL TRANSMISSION AND DIFFERENTIAL

9) After rotating the drive pinion shaft several times, measure the hypoid gear backlash using the ST.

ST1 498255400 PLATE
ST2 498247001 MAGNET BASE
ST3 498247100 DIAL GAUGE

Hypoid gear backlash:

0.13 — 0.18 mm (0.0051 — 0.0071 in)

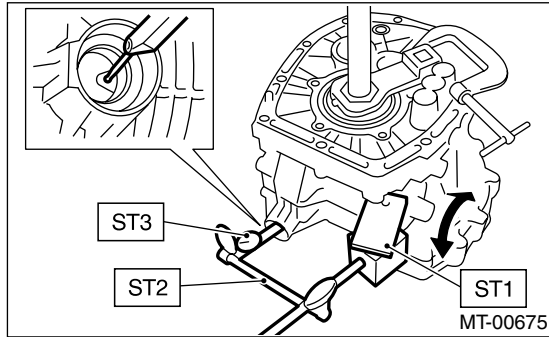

10) If the backlash is out of specification, adjust it by turning the right and left side retainers.

11) Screw in the right side retainer for further 1.75 teeth.

2. TOOTH CONTACT OF HYPOID GEAR

Refer to the section of drive pinion shaft for checking of tooth contact. <Ref. to 6MT-107, TOOTH CONTACT OF HYPOID GEAR, INSPECTION, Front Differential Assembly.>