

SHIFTER FORK AND ROD

MANUAL TRANSMISSION AND DIFFERENTIAL

25. Shifter Fork and Rod

A: REMOVAL

- 1) Remove the manual transmission assembly from vehicle. <Ref. to 6MT-35, REMOVAL, Manual Transmission Assembly.>
- 2) Prepare the transmission for overhaul. <Ref. to 6MT-40, Preparation for Overhaul.>
- 3) Remove the oil pipe, neutral position switch, back-up light switch and harness. <Ref. to 6MT-42, REMOVAL, Oil Pipe.>, <Ref. to 6MT-45, REMOVAL, Neutral Position Switch.>, <Ref. to 6MT-43, REMOVAL, Back-up Light Switch.>
- 4) Remove the extension case. <Ref. to 6MT-47, REMOVAL, Extension Case.>
- 5) Remove the transfer driven gear. <Ref. to 6MT-58, REMOVAL, Transfer Driven Gear.>
- 6) Remove the center differential. <Ref. to 6MT-60, REMOVAL, Center Differential.>
- 7) Remove the oil pump. <Ref. to 6MT-61, REMOVAL, Oil Pump.>
- 8) Remove the transmission case. <Ref. to 6MT-65, REMOVAL, Transmission Case.>
- 9) Remove each gear assembly. <Ref. to 6MT-70, REMOVAL, Main Shaft Assembly.>

B: INSTALLATION

- 1) Install each gear assembly at once. <Ref. to 6MT-71, INSTALLATION, Main Shaft Assembly.>
- 2) Install the transmission case. <Ref. to 6MT-66, INSTALLATION, Transmission Case.>
- 3) Install the oil pump. <Ref. to 6MT-62, INSTALLATION, Oil Pump.>
- 4) Install the center differential. <Ref. to 6MT-60, INSTALLATION, Center Differential.>
- 5) Install the transfer driven gear. <Ref. to 6MT-58, INSTALLATION, Transfer Driven Gear.>
- 6) Install the extension case. <Ref. to 6MT-47, INSTALLATION, Extension Case.>
- 7) Install the oil pipe, neutral position switch, back-up light switch and harness. <Ref. to 6MT-42, INSTALLATION, Oil Pipe.>, <Ref. to 6MT-45, INSTALLATION, Neutral Position Switch.>, <Ref. to 6MT-43, INSTALLATION, Back-up Light Switch.>
- 8) Install the manual transmission assembly to vehicle. <Ref. to 6MT-37, INSTALLATION, Manual Transmission Assembly.>

C: DISASSEMBLY

NOTE:

Discard the removed spring pin and replace it with a new one.

1. REVERSE SHIFTER FORK

- 1) Using the ST, remove the reverse fork.

ST 398791700 REMOVER

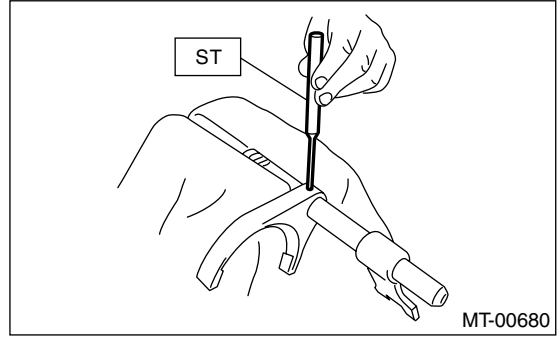

- 2) Using the ST, remove the reverse shifter arm.
ST 398791700 REMOVER

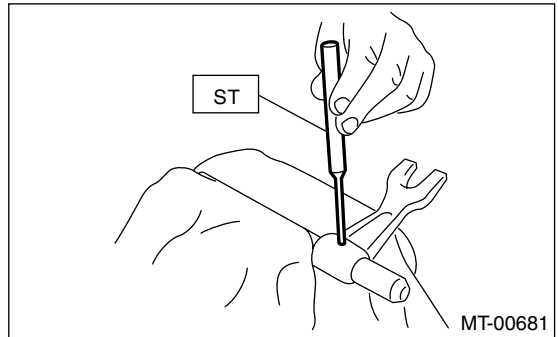

2. 1st-2nd, 3rd-4th SHIFTER FORK

- 1) Using the ST, remove the 3rd-4th shifter fork.
ST 398791700 REMOVER

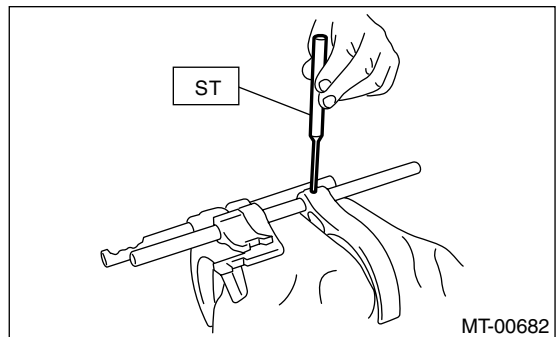

- 2) Using the ST, remove the 1st-2nd shifter arm.
ST 398791700 REMOVER

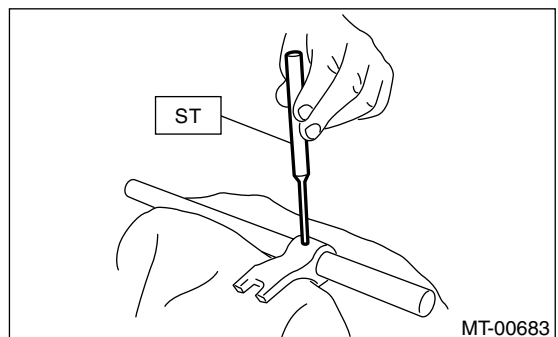

- 3) Using the ST, remove the 1st-2nd shifter arm and 1st-2nd shifter fork.

SHIFTER FORK AND ROD

MANUAL TRANSMISSION AND DIFFERENTIAL

ST 398791700 REMOVER

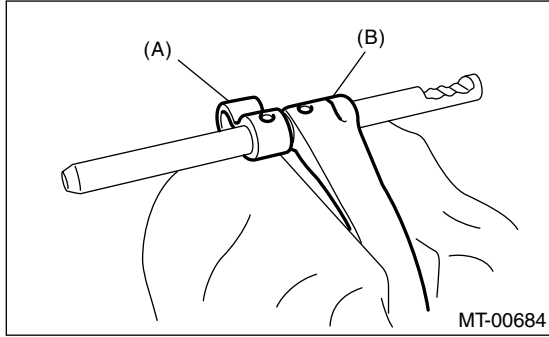

- (A) 1st-2nd shifter arm
- (B) 1st-2nd shifter fork

3. 5th-6th SHIFTER FORK

1) Using the ST, remove the 5th-6th shifter fork.

ST 398791700 REMOVER

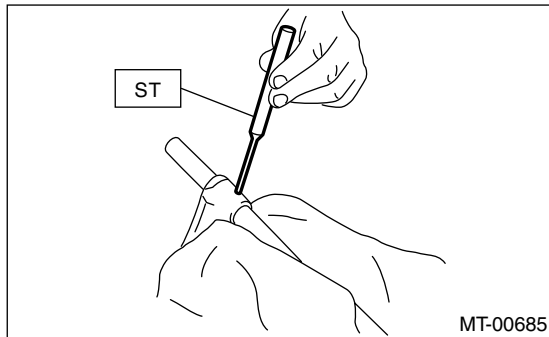

2) Using the ST, remove the 5th-6th shifter arm.

ST 398791700 REMOVER

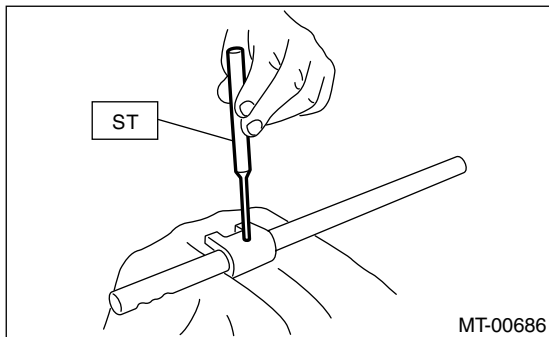

4. SHIFT ARM SHAFT

Using the ST, remove the selector arm.

ST 398791700 REMOVER

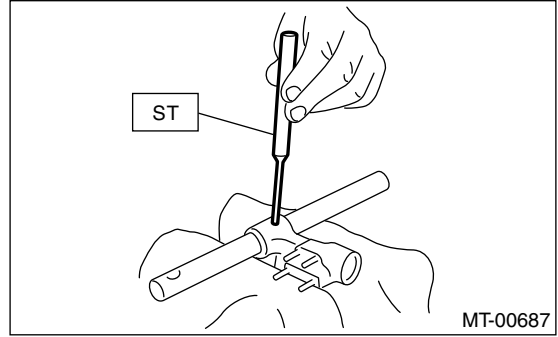

5. STRIKING ROD

1) Remove the reverse interlock block and interlock block from striking rod.

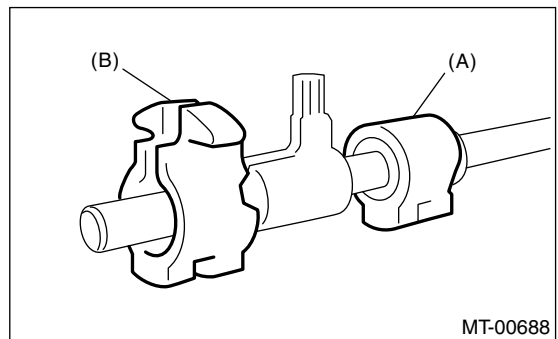

- (A) Reverse interlock block
- (B) Interlock block

2) Using the ST, remove the reverse interlock arm.

ST 398791700 REMOVER

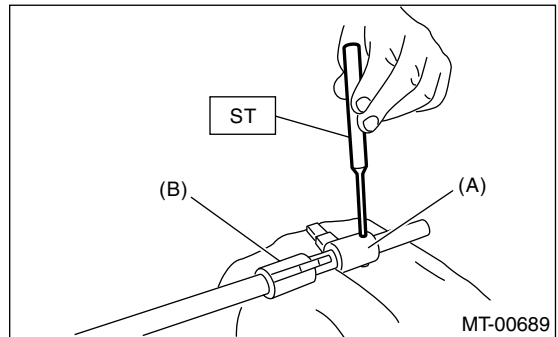

- (A) Reverse interlock arm
- (B) Interlock arm

3) Using the ST, remove the interlock arm.

SHIFTER FORK AND ROD

MANUAL TRANSMISSION AND DIFFERENTIAL

ST 398791700 REMOVER

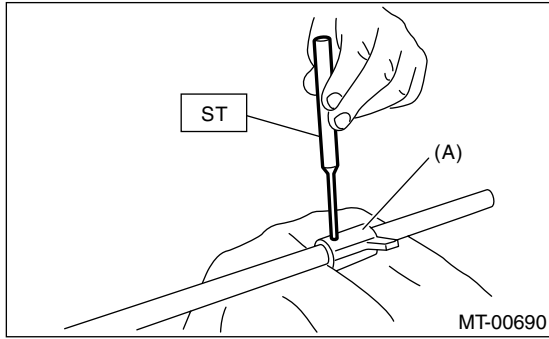

(A) Interlock arm

NOTE:

Make sure to install the reverse arm and rod in proper direction.

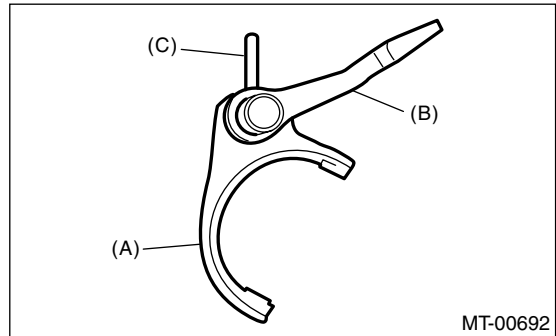

- (A) Reverse arm
- (B) Reverse rod
- (C) Spring pin

D: ASSEMBLY

1. REVERSE SHIFTER FORK

1) Using the ST, install the reverse fork.

ST 398791700 REMOVER

NOTE:

Make sure to install the reverse fork and rod in proper direction.

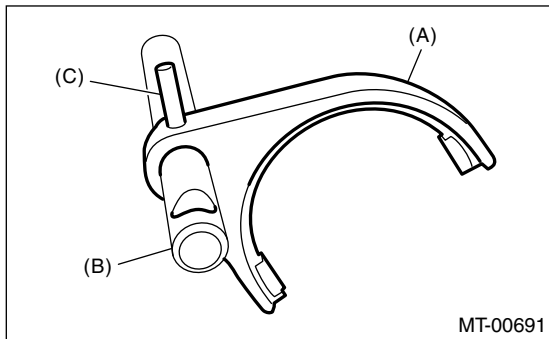

- (A) Reverse fork
- (B) Reverse rod
- (C) Spring pin

2) Using the ST, install the reverse arm.

ST 398791700 REMOVER

2. 1st-2nd, 3rd-4th SHIFTER FORK

1) Using the ST, install the 1st-2nd shifter fork.

ST 398791700 REMOVER

NOTE:

Make sure to install the 1st-2nd shifter fork and rod in proper direction.

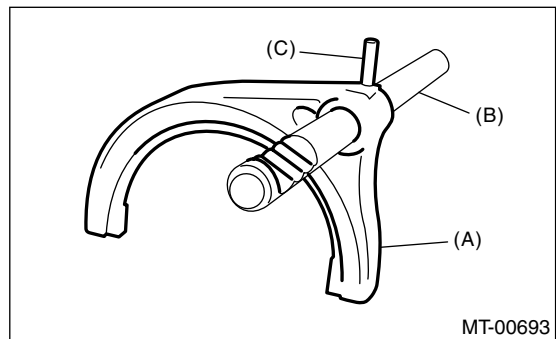

- (A) 1st-2nd shifter fork
- (B) 1st-2nd shifter rod
- (C) Spring pin

2) Using the ST, install the 1st-2nd shifter arm.

ST 398791700 REMOVER

SHIFTER FORK AND ROD

MANUAL TRANSMISSION AND DIFFERENTIAL

NOTE:

Make sure to install the 1st-2nd shifter arm and fork in proper direction.

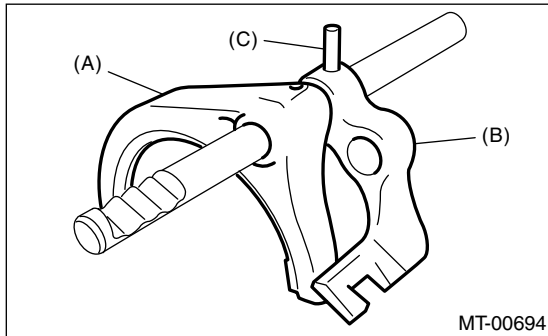

- (A) 1st-2nd shifter fork
- (B) 1st-2nd shifter arm
- (C) Spring pin

3) Using the ST, install the 3rd-4th shifter arm.
ST 398791700 REMOVER

NOTE:

Make sure to install the 3rd-4th shifter arm and rod in proper direction.

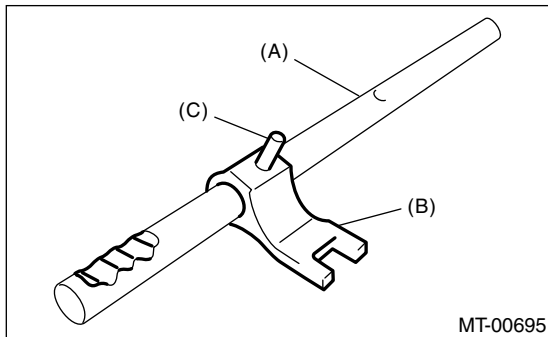

- (A) 3rd-4th shifter rod
- (B) 3rd-4th shifter arm
- (C) Spring pin

4) Install the 3rd-4th fork rod into 1st-2nd shifter arm.

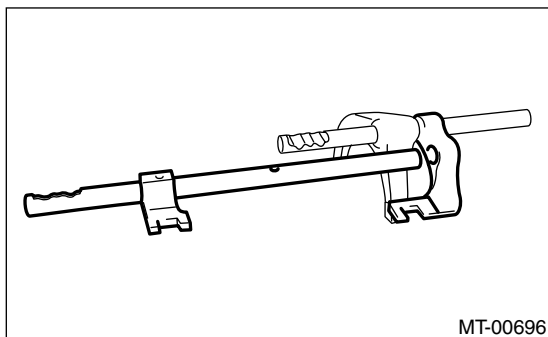

5) Using the ST, install the 3rd-4th shifter fork.
ST 398791700 REMOVER

NOTE:

Make sure to install the 3rd-4th shifter fork in proper direction.

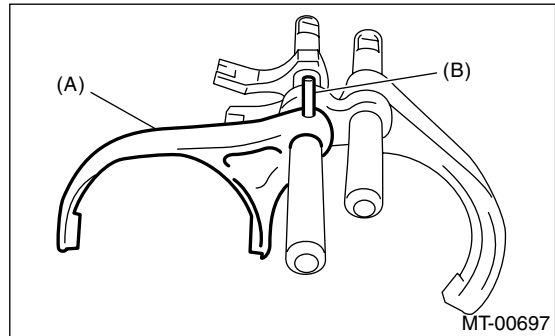

- (A) 3rd-4th shifter fork
- (B) Spring pin

3. 5th-6th SHIFTER FORK

1) Using ST, install the 5th-6th shifter arm.
ST 398791700 REMOVER

NOTE:

Make sure to install the 5th-6th shifter arm and rod in proper direction.

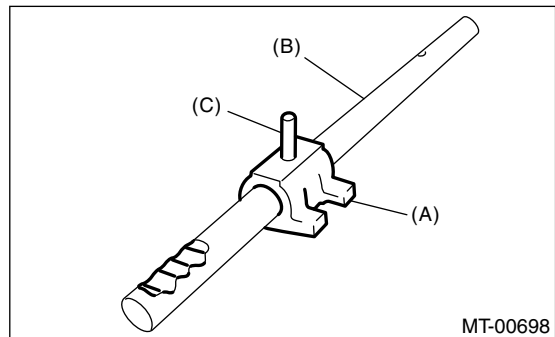

- (A) 5th-6th shifter arm
- (B) 5th-6th shifter rod
- (C) Spring pin

2) Using the ST, install the 5th-6th shifter fork.
ST 398791700 REMOVER

SHIFTER FORK AND ROD

MANUAL TRANSMISSION AND DIFFERENTIAL

NOTE:

Make sure to install the 5th-6th shifter fork and arm in proper direction.

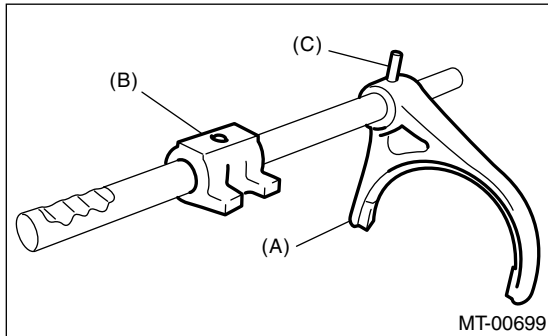

- (A) 5th-6th shifter fork
- (B) 5th-6th shifter arm
- (C) Spring pin

4. SHIFT ARM SHAFT

Using the ST, install the selector arm.
ST 398791700 REMOVER

NOTE:

Make sure to install the selector arm and rod in proper direction.

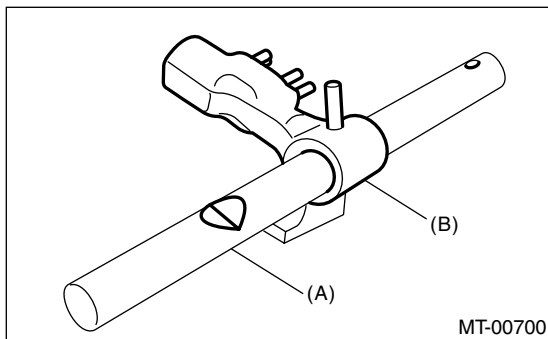

- (A) Selector rod
- (B) Selector arm

5. STRIKING ROD

1) Using the ST, install the reverse interlock arm and interlock arm.

ST 398791700 REMOVER

NOTE:

• Make sure to install the reverse interlock arm and rod in proper direction.

• Make sure to install the interlock arm and rod in proper direction.

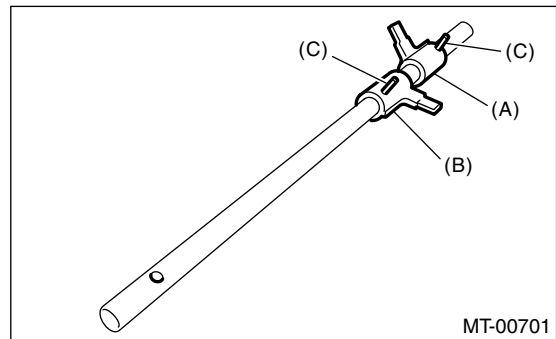

- (A) Reverse interlock arm
- (B) Interlock arm
- (C) Spring pin

2) Install the reverse interlock block and interlock block to striking rod.

NOTE:

Make sure to install the reverse interlock block and interlock block in proper direction.

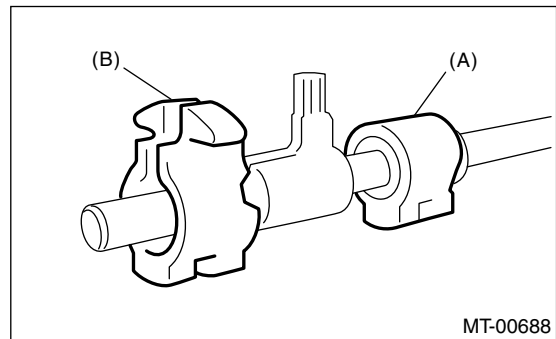

- (A) Reverse interlock block
- (B) Interlock block

E: INSPECTION

1) Check the shift shaft and shift rod for damage. Replace if damaged.

2) Repair or replace the gearshift mechanism if excessively worn, bent, or defective in any way.

SHIFTER FORK AND ROD

MANUAL TRANSMISSION AND DIFFERENTIAL

F: ADJUSTMENT

1. SELECTION OF 1st-2nd FORK ROD

NOTE:

- Perform the following procedures when.
Replacing the 1st, 2nd driven gear.
- Replacing the 1st, 2nd synchro ring assembly.
- Replacing the adapter plate.
- Replacing the driven shaft.
- Replacing the 1st-2nd hub, sleeve assembly.

1) Insert the drive pinion assembly in adapter plate.

NOTE:

Make sure the thrust bearing outer race is not removed and drive pinion is not lift-up.

2) Set the height gauge to adapter plate. Lower the indicator of height gauge to mating surface of adapter plate and case, then set to zero point.

ST 18853AA000 HEIGHT GAUGE

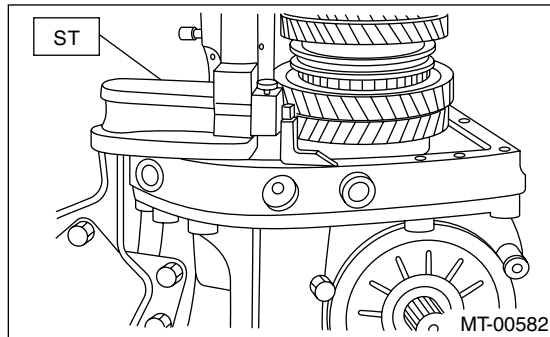

NOTE:

- Remove the remaining gasket on edge surface with scraper, since the adapter plate is base point of measurement.
- Do not place the height gauge on shaded area in the figure during measurement.

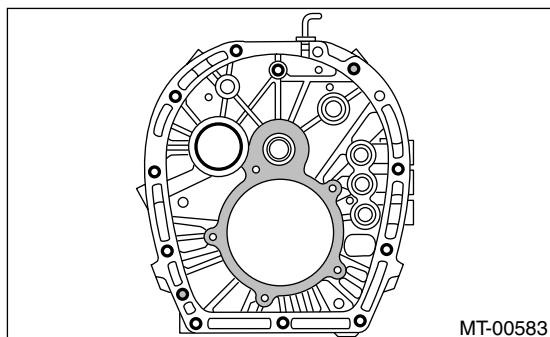

3) Select the main shaft snap ring. <Ref. to 6MT-82, ADJUSTMENT, Main Shaft Assembly.>

4) Measure "B1" and "B2" as shown in the figure.

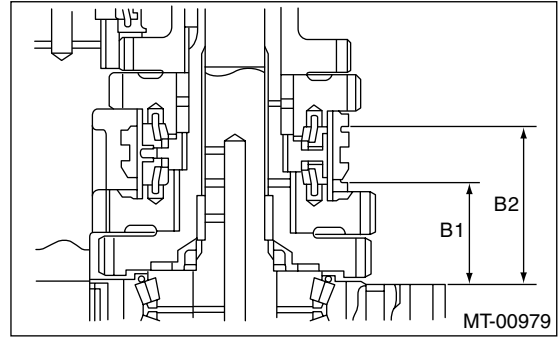

(1) Shift the 1st-2nd sleeve to 1st driven gear side, then press down to the stopper and measure "B1".

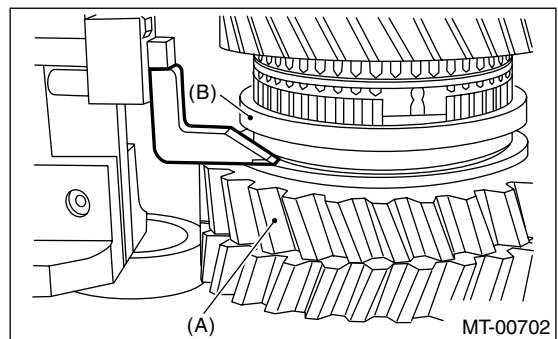

(A) 1st driven gear

(B) 1st-2nd sleeve

NOTE:

- Set the indicator of height gauge near measuring object, then lock the dial (1) as shown in the figure. Turn dial (2) to set the indicator to edge surface of sleeve 1st side.
- Measure five points of the sleeve turning every approx. 72°. Round off each two upper and lower measurement value. Use the remaining center value as measurement value.

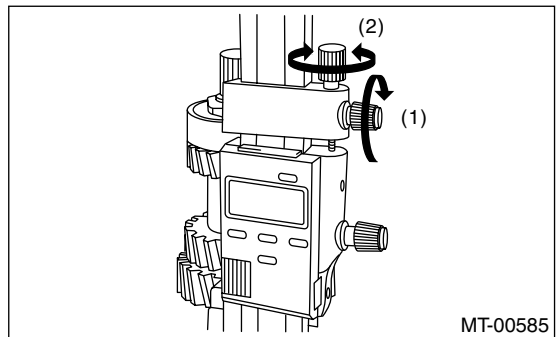

SHIFTER FORK AND ROD

MANUAL TRANSMISSION AND DIFFERENTIAL

(2) Set the height gauge indicator upside down.

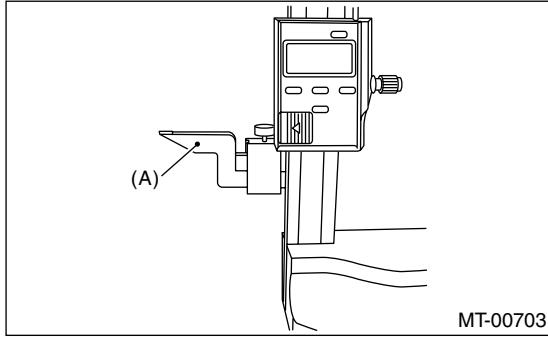

(A) Indicator

(3) Shift the 1st-2nd sleeve to 2nd driven gear side, then press up to the stopper and measure "B2".

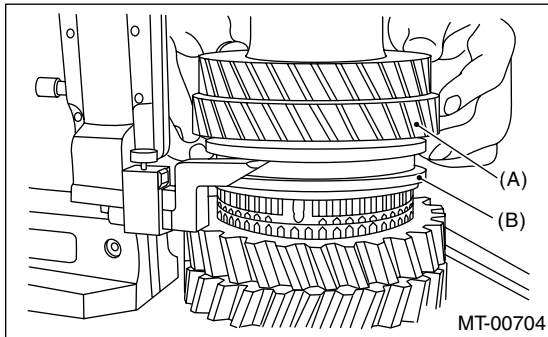

(A) 2nd driven gear
(B) 1st-2nd sleeve

NOTE:

- Set the indicator of height gauge near measuring object, then lock the dial (1) as shown in the figure. Turn dial (2) to set the indicator to edge surface of sleeve 2nd side.
- Perform the measuring procedure with two people, and measure the sleeve lifted up straight.
- Measure five points of the sleeve turning every approx. 72° apart. Round off each two upper and lower measurement value. Use the remaining center value as measurement value.

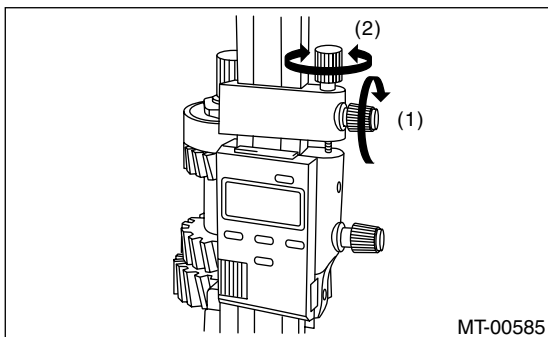

(4) According to both measurements, calculate the 1st-2nd sleeve neutral position. Select the fork rod which applies to the calculated value from following equation.

Equation: $T = (B1 + B2) / 2$

T: 1st-2nd sleeve center position

B1: Height from adapter plate edge to sleeve edge when shifted to 1st gear.

B2: Height from adapter plate edge to sleeve edge when shifted to 2nd gear. [measurement value + 55 mm (2.17 in)]

NOTE:

The indicator is installed upside down compared to the setting procedure of zero point. Add d1 [fixing value: 55 mm (2.17 in)] from the following figure to "B2", to obtain measurement value of "B2".

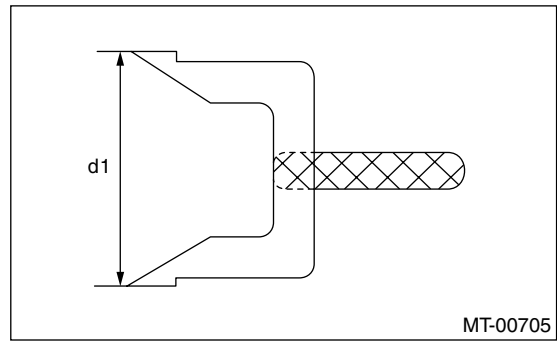

T	mm (in)	Lot No. (Mark)
	62.93 — 63.23 (2.4776 — 2.4894)	32801AA111 (1)
	63.23 — 63.53 (2.4894 — 2.5012)	32801AA131 (None)
	63.53 — 63.83 (2.5012 — 2.5130)	32801AA141 (2)

SHIFTER FORK AND ROD

MANUAL TRANSMISSION AND DIFFERENTIAL

2. SELECTION OF 3rd-4th FORK ROD

NOTE:

Perform the following procedures when.

- Replacing the main shaft.
- Replacing the 3rd, 3rd to 6th drive gear and bush.
- Replacing the 3rd, 3rd to 6th synchro assembly.
- Replacing the 3rd-4th hub, sleeve assembly.

- 1) Insert the main shaft assembly in adapter plate.
- 2) Set the height gauge to adapter plate. Lower the indicator of height gauge to upper surface of snap ring groove, on the upper side of main rear bearing, then set to zero point.

ST 18853AA000 HEIGHT GAUGE

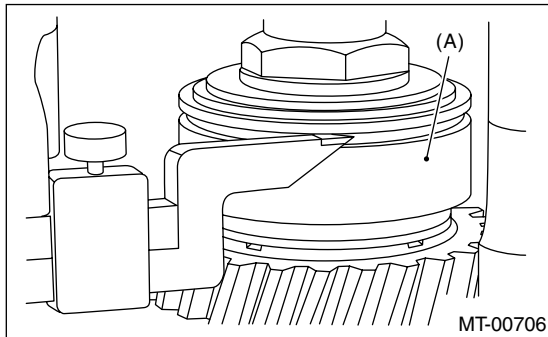

(A) Roller bearing

NOTE:

- Remove the remaining gasket on edge surface with scraper, since the height gauge is set on adapter plate during measurement.
- Do not put the height gauge on shaded area in the figure during the measurement.

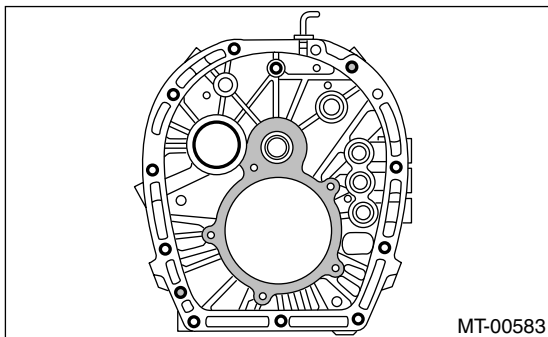

- 3) Using the height gauge, measure "C1" and "C2" shown in the figure.

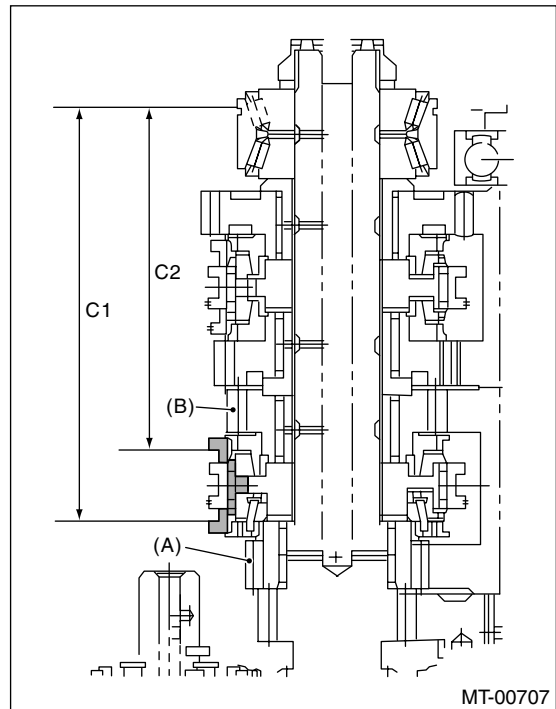

(A) 3rd drive gear

(B) 4th drive gear

- (1) Shift the 3rd-4th sleeve to 4th gear side, then press up to the stopper and measure "C2".

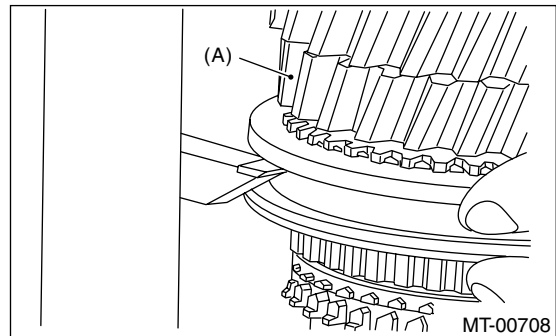

(A) 4th drive gear

NOTE:

- Set the indicator of height gauge near measuring object, then lock the dial (1) as shown in the figure.
- Turn dial (2) to set the indicator to edge surface of sleeve 4th side.
- Perform the measuring procedure with two people, and measure the sleeve lifted up straight.

SHIFTER FORK AND ROD

MANUAL TRANSMISSION AND DIFFERENTIAL

- Measure five points of the sleeve turning every approx. 72°. Round off each two upper and lower measurement value. Use the remaining center value as measurement value.

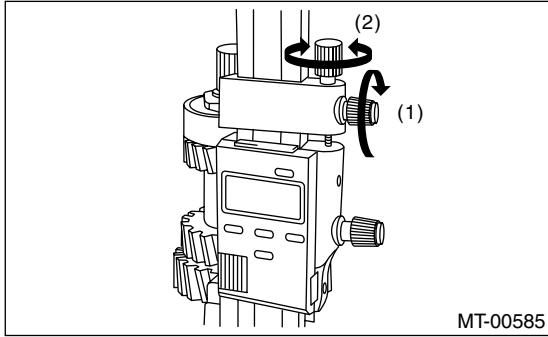

(2) Set the height gauge indicator upside down.

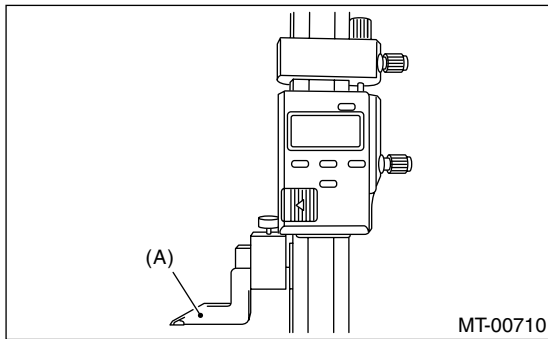

(A) Indicator

(3) Shift the 3rd-4th sleeve to 3rd drive gear side, then press down to the stopper and measure "C1".

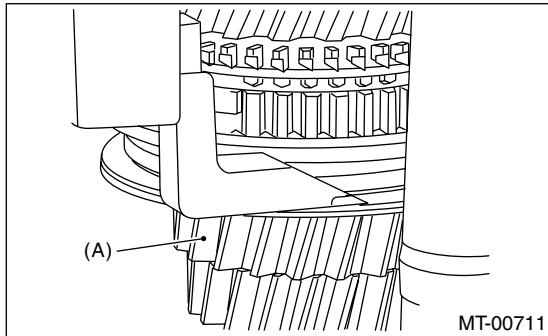

(A) 3rd drive gear

NOTE:

- Set the indicator of height gauge near measuring object, then lock the dial (1) as shown in the figure. Turn dial (2) to set the indicator to edge surface of sleeve 3rd side.

- Measure five points of the sleeve turning every approx. 72°. Round off each two upper and lower measurement value. Use the remaining center value as measurement value.

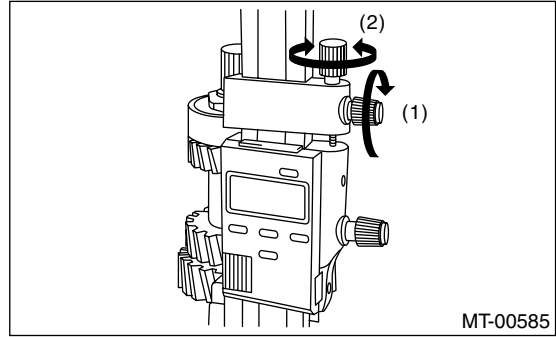

4) According to both measurements, calculate the 3rd-4th sleeve neutral position. Select the fork rod which applies to the calculated value from following equation.

Equation: $T = (C1 + C2) / 2$

- T: 3rd-4th sleeve center position
- C1: Length from main shaft rear bearing snap ring groove to sleeve edge when shifted to 3rd gear. [measurement value +55 mm (2.17 in)]
- C2: Length from main shaft rear bearing snap ring groove to sleeve edge when shifted to 4th gear.

NOTE:

The indicator is installed upside down compared to the setting procedure of zero point. Add d1 [fixing value: 55 mm (2.17 in)] from the following figure to "C1", to obtain measurement value of "C1".

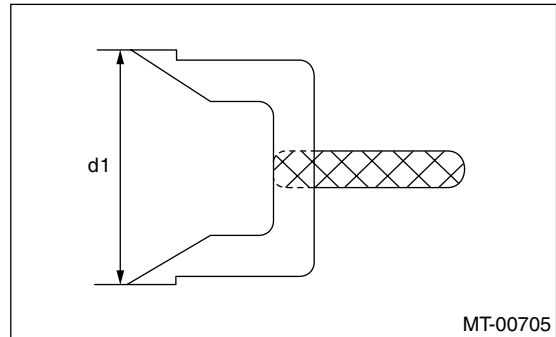

SHIFTER FORK AND ROD

MANUAL TRANSMISSION AND DIFFERENTIAL

T mm (in)	Lot No. (Mark)		
	M.SFT Snap ring 805072010 [t=1.65 mm (0.065 in)]	M.SFT Snap ring 805072011 [t=1.95 mm (0.077 in)]	M.SFT Snap ring 805072012 [t=2.25 mm (0.089 in)]
137.22 — 137.52 (5.4024 — 5.4142)	32809AA171 (None)	32809AA181 (2)	32809AA191 (4)
137.52 — 137.82 (5.4142 — 5.4260)	32809AA161 (1)	32809AA171 (None)	32809AA181 (2)
137.82 — 138.12 (5.4260 — 5.4379)	32809AA141 (3)	32809AA161 (1)	32809AA171 (None)

T = Thickness

3. SELECTION OF 5th-6th FORK ROD

NOTE:

Perform the following procedures when.

- Replacing the main shaft.
- Replacing the 3rd to 6th drive gear and bush.
- Replacing the 3rd to 6th synchro ring assembly.
- Replacing the 3rd-4th hub, sleeve assembly.
- Replacing the 5th-6th hub, sleeve assembly.

- 1) Insert the main shaft assembly in adapter plate.
- 2) Set the height gauge to adapter plate. Lower the indicator of height gauge to upper surface of snap ring groove, or the upper side of main rear bearing. Then set to zero point.

ST 18853AA000 HEIGHT GAUGE

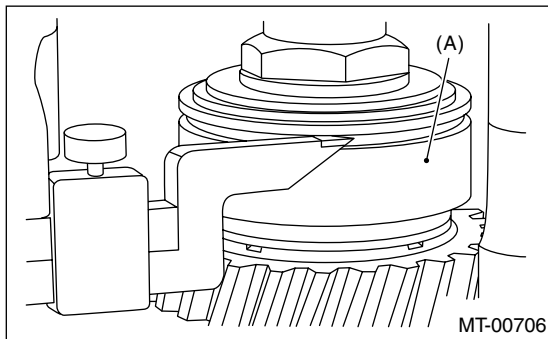

(A) Ball bearing

NOTE:

- Remove the remaining gasket on edge surface with scraper, since the height gauge is set on adapter plate during measurement.

- Do not place the height gauge on shaded area in the figure during the measurement.

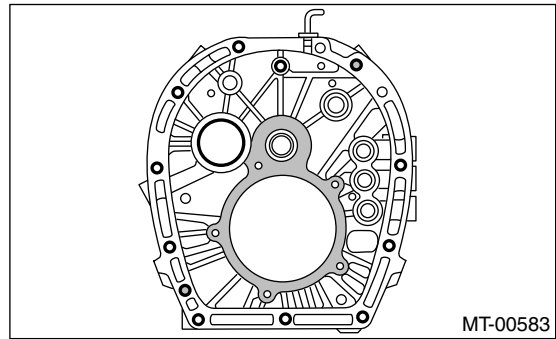

- 3) Using the height gauge, measure “D1” and “D2” shown in the figure.

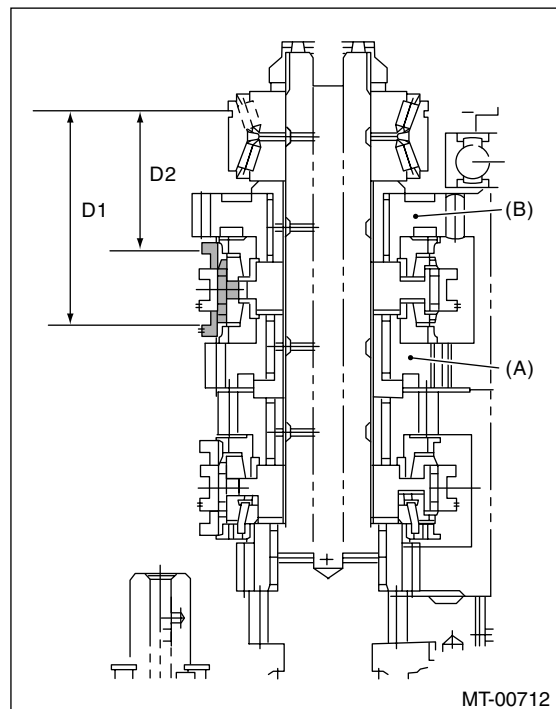

(A) 5th main gear

(B) 6th main gear

SHIFTER FORK AND ROD

MANUAL TRANSMISSION AND DIFFERENTIAL

(1) Shift the 5th-6th sleeve to 6th main gear side, then press up to the stopper and measure "D2".

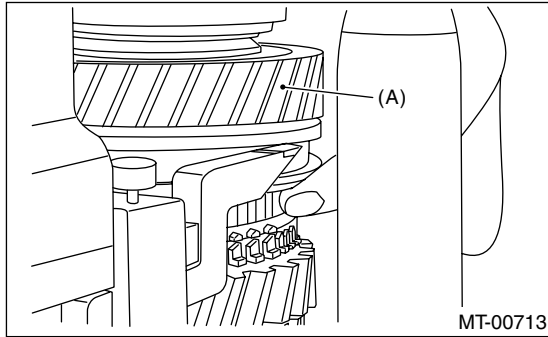

(A) 6th main gear

(3) Shift the 5th-6th sleeve to 5th main gear side, then press down to the stopper and measure "D1".

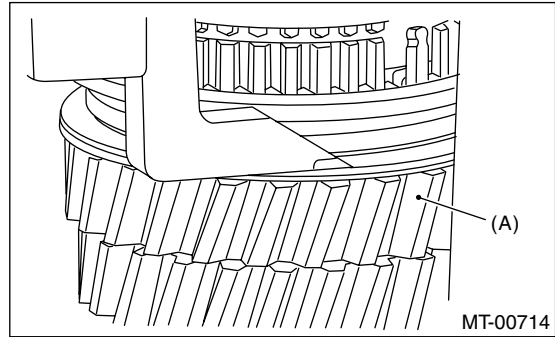

(A) 5th main gear

NOTE:

- Set the indicator of height gauge near measuring object, then lock the dial (1) as shown in the figure. Turn dial (2) to set the indicator to edge surface of sleeve 6th side.
- Perform the measuring procedure with two people, and measure the sleeve lifted up straight.
- Measure five points of the sleeve turning every approx. 72°. Round off each two upper and lower measurement value. Use the remaining center value as measurement value.

NOTE:

- Set the indicator of height gauge near measuring object, then lock the dial (1) as shown in the figure. Turn dial (2) to set the indicator to edge surface of sleeve 5th side.
- Measure five points of the sleeve turning every approx. 72°. Round off each two upper and lower measurement value. Use the remaining center value as measurement value.

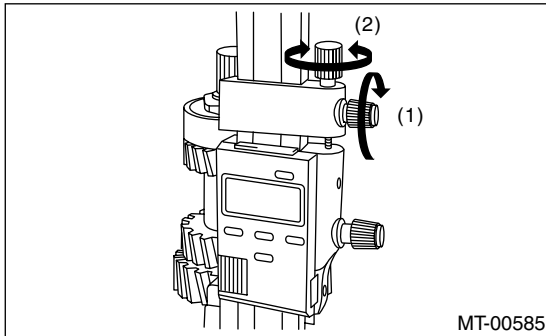

(2) Set the height gauge indicator upside down.

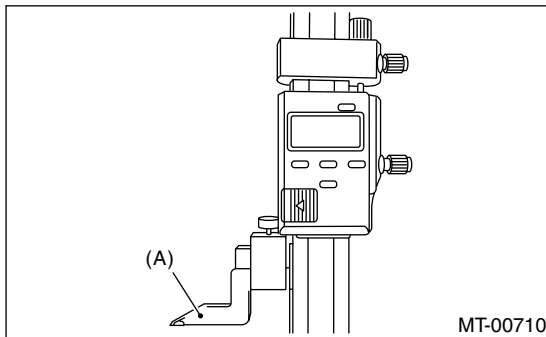

(A) Indicator

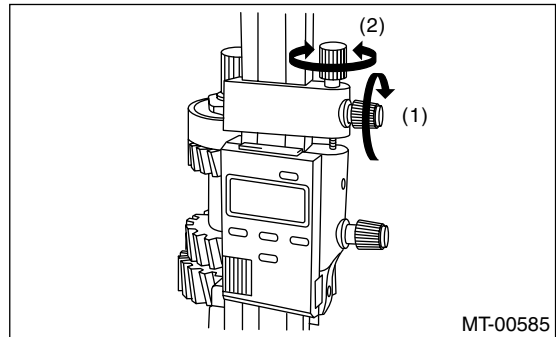

4) According to both measurements, calculate the 5th-6th sleeve neutral position. Select the fork rod, which applies to the calculated value from following equation.

$$\text{Equation: } T = (D1 + D2) / 2$$

- T: 5th-6th sleeve center position
- D1: Length from the shaft rear bearing snap ring groove to sleeve groove edge when shifted to 5th gear. [measurement value + 55 mm (2.17 in)]
- D2: Length from main shaft rear bearing snap ring groove to sleeve groove edge when shifted to 6th gear.

SHIFTER FORK AND ROD

MANUAL TRANSMISSION AND DIFFERENTIAL

NOTE:

The indicator is installed upside down compared to the setting procedure of zero point. Add d1 [fixing value: 55 mm (2.17 in)] from the following figure to “D1”, to obtain measurement value of “D1”.

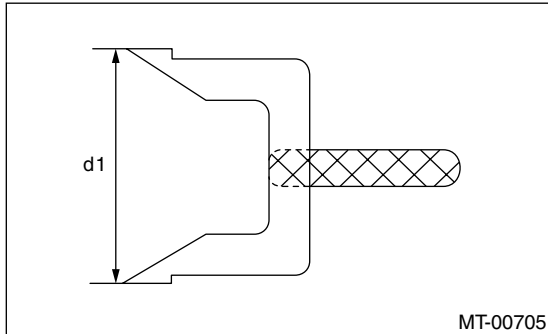

Tightening torque:

25 N·m (2.5 kgf·m, 18.1 ft·lb)

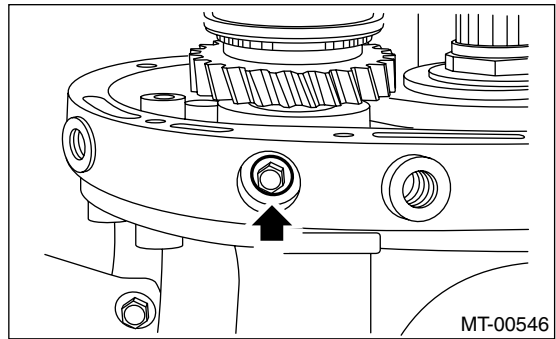

3) Set the height gauge to adapter plate. Lower the indicator of height gauge to mating surface of adapter plate and case, then set to zero point.
ST 18853AA000 HEIGHT GAUGE

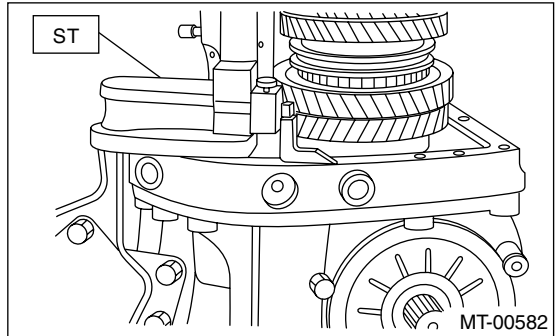

T mm (in)	Lot No. (Mark)		
	M.SFT Snap ring 805072010 [t=1.65 mm (0.065 in)]	M.SFT Snap ring 805072011 [t=1.95 mm (0.077 in)]	M.SFT Snap ring 805072012 [t=2.25 mm (0.089 in)]
64.12 — 64.42 (2.5244 — 2.5362)	32945AA021 (None)	32945AA031 (2)	32945AA041 (4)
64.42 — 64.72 (2.5362 — 2.5480)	32945AA011 (1)	32945AA021 (None)	32945AA031 (2)
64.72 — 65.02 (2.5480 — 2.5598)	32945AA001 (3)	32945AA011 (1)	32945AA021 (None)

T = Thickness

4. SELECTION OF REVERSE FORK ROD

NOTE:

Perform the following procedures when.

- Replacing the reverse idler gear.
- Replacing the reverse idler gear No. 2.
- Replacing the adapter plate.
- Replacing the base.

1) Insert the reverse idler gear assembly in adapter plate.

2) Tighten the base COMPL fixing bolt.

NOTE:

- Remove the remaining gasket on edge surface with scraper, since the adapter plate is base point of measurement.
- Do not place the height gauge on shaded area in the figure during measurement.

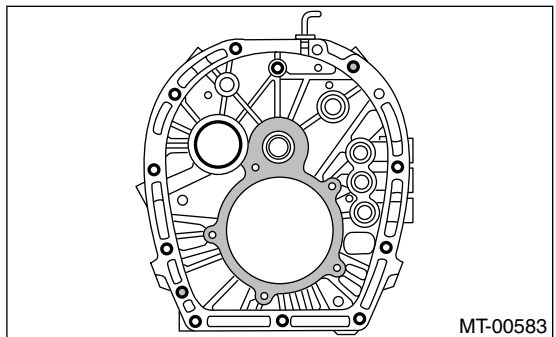

SHIFTER FORK AND ROD

MANUAL TRANSMISSION AND DIFFERENTIAL

4) Press the reverse sleeve to reverse side idler gear No. 2, then measure "T".

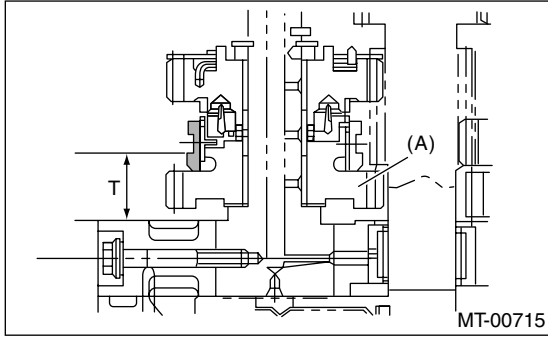

(A) Reverse idler gear No. 2

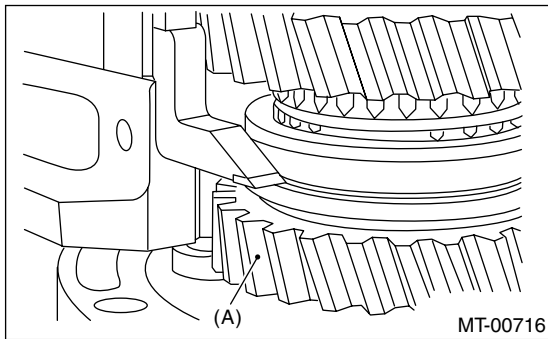

(A) Reverse idler gear No. 2

5) According to measurement, calculate the reverse sleeve neutral position. Select the fork rod which applies to the calculated value from following equation.

Equation: $T + 4.8 \text{ mm (0.189 in)}$

$T + 4.8 \text{ mm (0.189 in)}$	Lot No. (Mark)
33.50 — 33.80 (1.3189 — 1.3307)	32816AA110 (1)
33.80 — 34.10 (1.3307 — 1.3425)	32816AA130 (None)
34.10 — 34.40 (1.3425 — 1.3543)	32816AA140 (2)

T = Thickness

NOTE:

- Set the indicator of height gauge near measuring object, then lock the dial (1) as shown in the figure. Turn dial (2) to set the indicator to edge surface of reverse sleeve side.
- Measure five points of the sleeve turning every approx. 72° . Round off each two upper and lower measurement value. Use the remaining center value as measurement value.

