

## 2. ABS Control Module and Hydraulic Control Unit (ABSCM&H/U)

### A: REMOVAL

- 1) Disconnect the ground cable from battery.
- 2) Remove the air intake duct from engine compartment to facilitate removal of ABSCM&H/U.
- 3) Use an air gun to get rid of water around the ABSCM&H/U.

**NOTE:**

Contact will be insufficient if the terminal gets wet.

- 4) Remove the ground cable from ABSCM&H/U.
- 5) Pull off the lock of ABSCM&H/U connector to remove it.

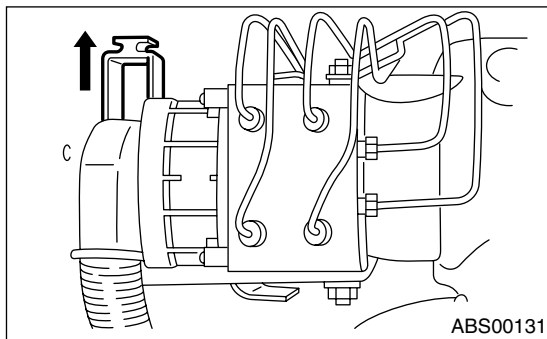

- 6) Disconnect the connector from ABSCM&H/U.

**CAUTION:**

**Do not pull the harness when disconnecting the connector.**

- 7) Unlock the cable clip.
- 8) Disconnect the brake pipes from ABSCM&H/U.
- 9) Wrap the brake pipes with vinyl bag to avoid spilling brake fluid on vehicle body.

**CAUTION:**

**Brake fluid spilt on the vehicle body will harm the painted surface; wash away quickly with water if spilt.**

- 10) Remove the ABSCM&H/U from engine compartment.

**CAUTION:**

- ABSCM&H/U cannot be disassembled. Do not attempt to loosen bolts and nuts.
- Do not drop or bump the ABSCM&H/U.
- Do not turn the ABSCM&H/U upside down or place it on its side.
- Be careful to prevent foreign particles from getting into ABSCM&H/U.

- Do not let water get into the connector.

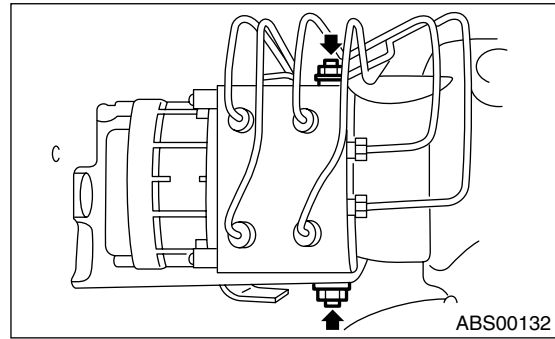

### B: INSTALLATION

- 1) Install the ABSCM&H/U bracket.

**Tightening torque:**

**33 N·m (3.3 kgf-m, 24 ft-lb)**

- 2) Apply a coat of grease (Nippeco LT or GB) to the bracket attaching bolt.
- 3) Align the width across flat portion of ABSCM&H/U side stud bolt with the bolt hole groove on bracket, and then install the ABSCM&H/U.

**NOTE:**

Confirm the specification mark of ABSCM&H/U.

**Tightening torque:**

**18 N·m (1.8 kgf-m, 13.0 ft-lb)**

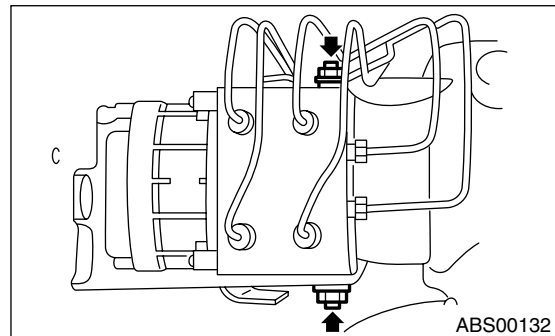

- 4) Connect the brake pipes to their correct ABSCM&H/U connections.

**Tightening torque:**

**15 N·m (1.5 kgf-m, 10.8 ft-lb)**

- 5) Using the cable clip, secure the ABSCM&H/U harness to bracket.
- 6) Connect the connector to ABSCM&H/U.

**NOTE:**

- Be sure to remove all foreign matter from inside of the connector before connecting.
- Ensure the ABSCM&H/U connector is securely locked.

- 7) Connect the ground cable to ABSCM&H/U, and then apply grease.

- 8) Install the air intake duct.

- 9) Bleed air from the brake system.

## C: INSPECTION

- 1) Check the connected and fixed condition of connector.
- 2) Check specifications of the mark with ABSCM&H/U.

Mark	Model
CU	AT model
CV	MT model (Except Sedan STi model)
CY	Sedan STi model

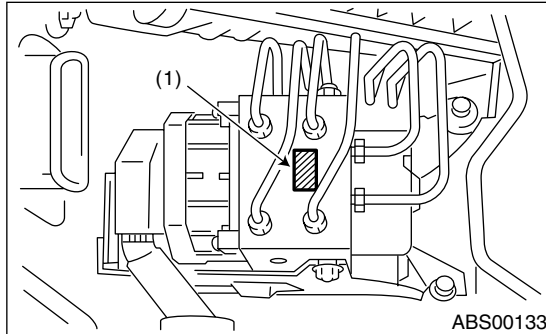

(1) Mark

### 1. CHECKING THE HYDRAULIC UNIT ABS OPERATION BY PRESSURE GAUGE

- 1) Lift-up the vehicle and remove the wheels.
- 2) Disconnect the air bleeder screws from the FL and FR caliper bodies.
- 3) Connect two pressure gauges to the FL and FR caliper bodies.

#### CAUTION:

- Pressure gauges used exclusively for brake fluid must be used.
- Do not employ pressure gauge previously used for transmission since the piston seal is expanded which may lead to malfunction of the brake.

#### NOTE:

Wrap sealing tape around the pressure gauge.

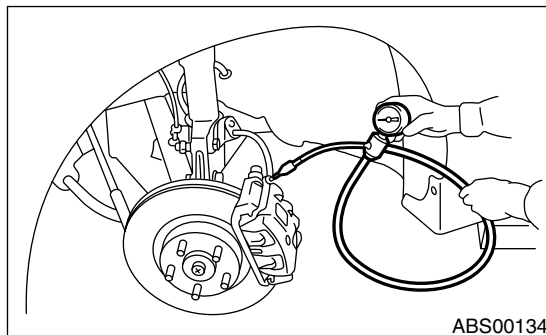

- 4) Bleed air from the pressure gauges.
- 5) Perform the ABS sequence control.  
<Ref. to ABS-9, ABS Sequence Control.>
- 6) When the hydraulic unit begins to work, and first the FL side performs decompression, holding, and compression, and then the FR side performs decompression, holding, and compression.
- 7) Read values indicated on the pressure gauge and check if the fluctuation of the values between decompression and compression meets the standard values. Also check if any irregular brake pedal tightness is felt.

	Front wheel	Rear wheel
Initial value	3,500 kPa (36 kgf/cm <sup>2</sup> , 511 psi)	3,500 kPa (36 kgf/cm <sup>2</sup> , 511 psi)
Decompressed	500 kPa (5 kgf/cm <sup>2</sup> , 73 psi) or less	500 kPa (5 kgf/cm <sup>2</sup> , 73 psi) or less
Compressed	3,500 kPa (36 kgf/cm <sup>2</sup> , 511 psi) or more	3,500 kPa (36 kgf/cm <sup>2</sup> , 511 psi) or more

- 8) Remove the pressure gauges from the FL and FR caliper bodies.
- 9) Remove the air bleeder screws from the RL and RR caliper bodies.
- 10) Connect the air bleeder screws to the FL and FR caliper bodies.
- 11) Connect two pressure gauges to the RL and RR caliper bodies.
- 12) Bleed air from the pressure gauges and the FL and FR caliper bodies.
- 13) Perform the ABS sequence control.  
<Ref. to ABS-9, ABS Sequence Control.>
- 14) When the hydraulic unit begins to work, at first the RR side performs decompression, holding, and compression, and then the RL side performs decompression, holding, and compression.
- 15) Read values indicated on the pressure gauges and check if they meet the standard value.
- 16) After checking, remove the pressure gauges from caliper bodies.
- 17) Connect the air bleeder screws to RL and RR caliper bodies.
- 18) Bleed air from the brake line.

# ABS CONTROL MODULE AND HYDRAULIC CONTROL UNIT (ABSCM&H/U)

ABS

## 2. CHECKING THE HYDRAULIC UNIT ABS OPERATION WITH BRAKE TESTER

1) In the case of AWD AT models, install a spare fuse with the FWD connector in the main fuse box to simulate FWD models.

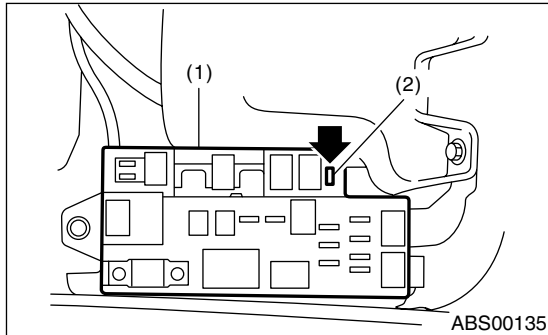

- (1) Main fuse box
- (2) FWD connector

### NOTE:

AWD circuit of MT models can not be disabled because viscous coupling is used inside center differential.

2) Prepare for operating the ABS sequence control. <Ref. to ABS-9, ABS Sequence Control.>

3) Set the front wheels or rear wheels on the brake tester and set the select lever's position at "N" range.

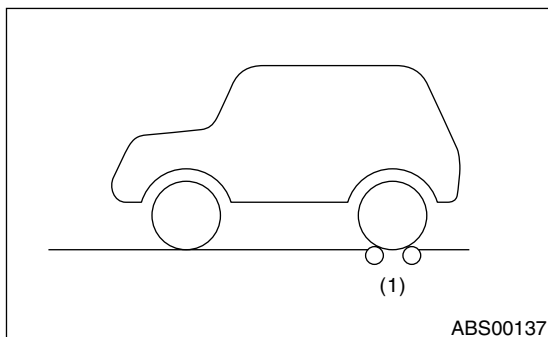
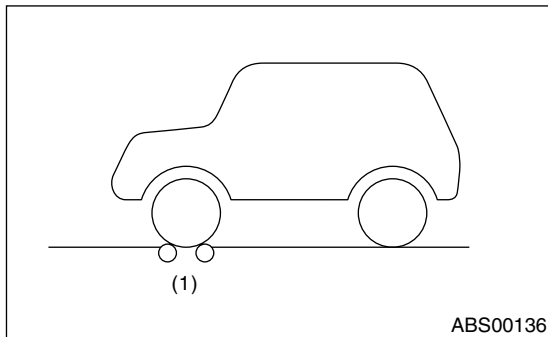

- (1) Brake tester

4) Operate the brake tester.

5) Perform the ABS sequence control.

<Ref. to ABS-9, ABS Sequence Control.>

6) Hydraulic unit begins to work; and check the following working sequence.

(1) The FL wheel performs decompression, holding, and compression in sequence, and subsequently the FR wheel repeats the cycle.

(2) The RR wheel performs decompression, holding, and compression in sequence, and subsequently the RL wheel repeats the cycle.

7) Read values indicated on the brake tester and check if the fluctuation of values, when decompressed and compressed, meets the standard values.

	Front wheel	Rear wheel
Initial value	1,000 N (102 kgf, 225 lb)	1,000 N (102 kgf, 225 lb)
Decompressed	500 N (51 kgf, 112 lb) or less	500 N (51 kgf, 112 lb) or less
Compressed	1,000 N (102 kgf, 225 lb) or more	1,000 N (102 kgf, 225 lb) or more

8) After checking, also check if any irregular brake pedal tightness is felt.