

FRONT BRAKE PAD

BRAKE

2. Front Brake Pad

A: REMOVAL

1. 15 INCH TYPE

- 1) Set the vehicle on a lift.
- 2) Loosen the wheel nuts.
- 3) Lift-up the vehicle, and then remove the front wheel.
- 4) Remove the lower caliper bolt.
- 5) Raise the caliper body upward and support it.

NOTE:

Do not disconnect the brake hose from caliper body.

- 6) Remove the pad.

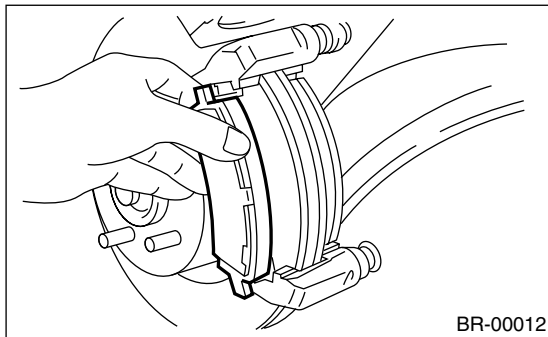

NOTE:

If the brake pad is difficult to remove, proceed as follows:

- (1) Remove the caliper body from support.
- (2) Remove the support.
- (3) Place a support in a vise between wooden blocks.

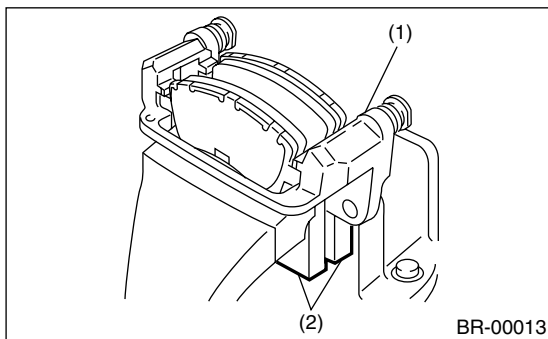

- (1) Support
- (2) Wooden blocks

- (4) Attach a rod of less than 12 mm (0.47 in) dia. to the shaded area of brake pad, and strike the rod with a hammer to drive brake pad out of place.

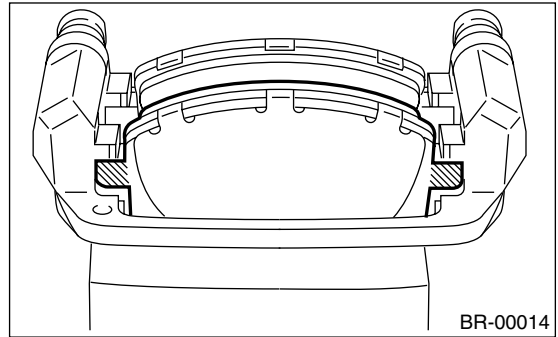

2. 16 INCH TYPE

- 1) Set the vehicle on a lift.
- 2) Loosen the wheel nuts.
- 3) Lift-up the vehicle, and then remove the front wheel.
- 4) Remove the M clip.

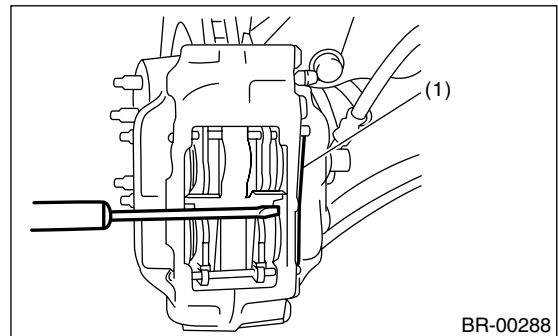

- (1) M clip

- 5) Remove the pad pins, then remove the cross spring.

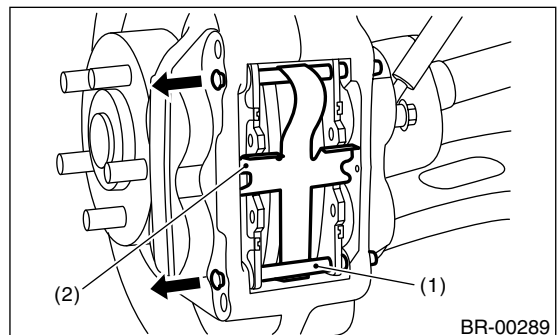

- (1) Pad pin
- (2) Cross spring

FRONT BRAKE PAD

BRAKE

6) Use a wrench to expand the pads, and then push the piston back.

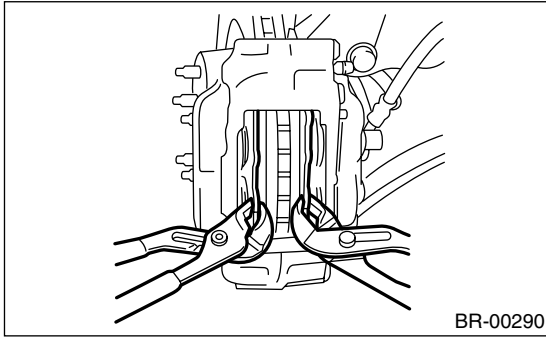

7) Remove the pad.

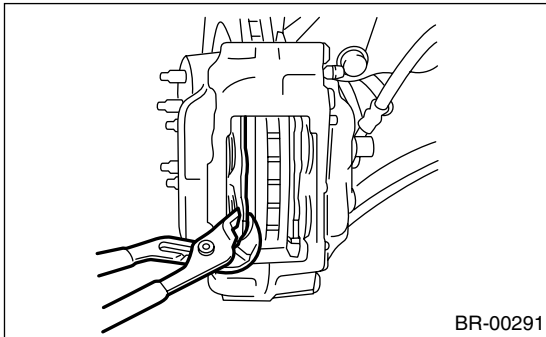

3. 17 INCH TYPE

- 1) Set the vehicle on a lift.
- 2) Loosen the wheel nuts.
- 3) Lift-up the vehicle, and then remove the front wheel.
- 4) Remove the clip.

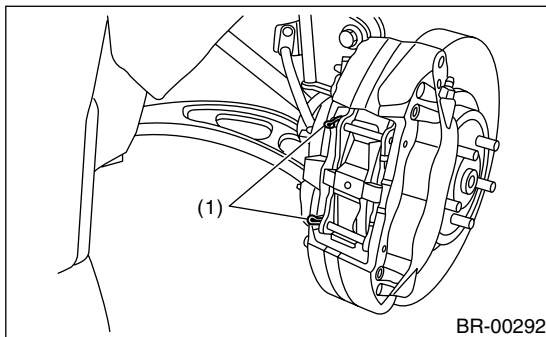

(1) Clip

5) Remove the pad pins and cross spring.

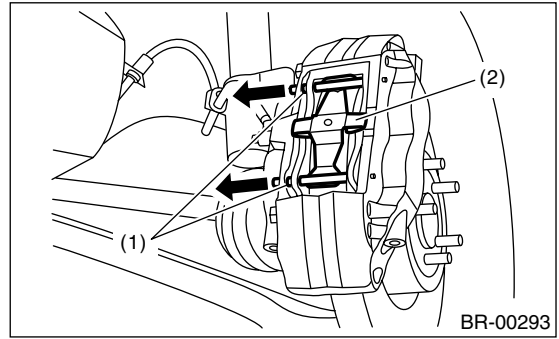

- (1) Pad pin
- (2) Cross spring

6) Use a wrench to expand the pads, and then push the piston back.

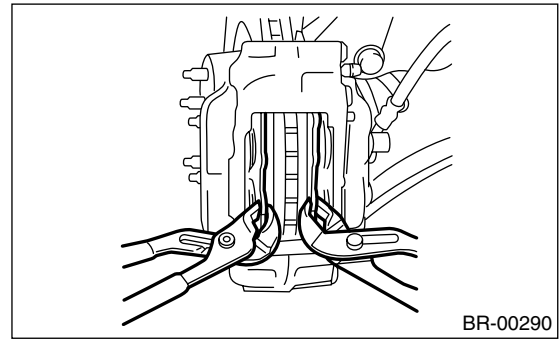

7) Remove the pad.

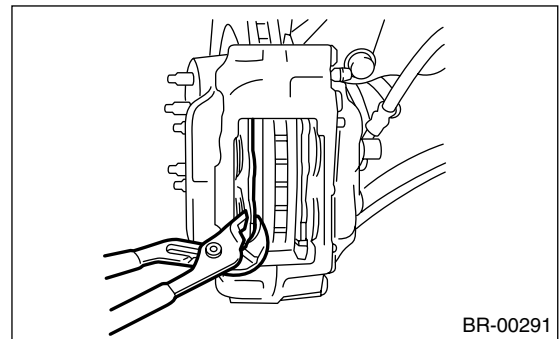

FRONT BRAKE PAD

BRAKE

B: INSTALLATION

1. 15 INCH TYPE

1) Apply thin coat of Molykote AS880N (Part No. K0779YA010) to the frictional portion between pad and pad clip.

2) Apply thin coat of Molykote AS880N (Part No. K0779YA010) to the frictional portion between pad and pad inner shim.

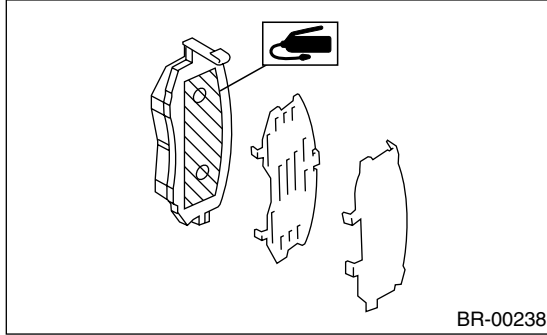

- 3) Install the pads on support.
- 4) Install the caliper body on support.

Tightening torque:

37 N-m (3.8 kgf-m, 27.5 ft-lb)

NOTE:

If it is difficult to push the piston during pad replacement, loosen the air bleeder to facilitate work.

2. 16 INCH TYPE

1) Apply thin coat of Molykote AS880N (Part No. K0779YA010) to the frictional portion between pad and pad inner shim.

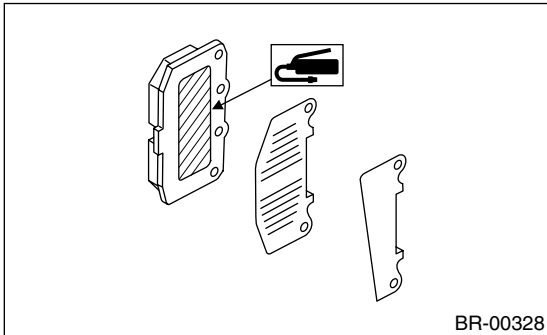

- 2) Install the pads on caliper body.
- 3) Install the pad pins on caliper body.
- 4) Install the M clip.
- 5) Install the cross spring.

3. 17 INCH TYPE

1) Apply thin coat of Molykote AS880N (Part No. K0779YA010) to the frictional portion between pad and pad shim.

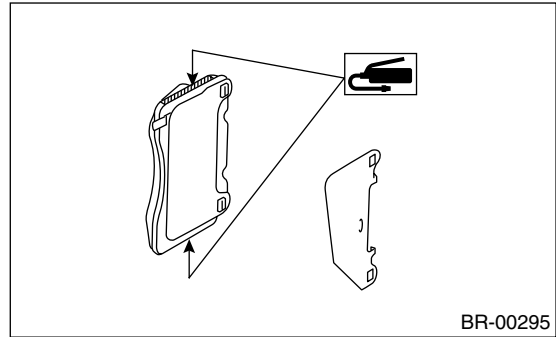

- 2) Install the pads on caliper body.
- 3) Install the cross spring.
- 4) Install the pad pins.
- 5) Install the clip.

C: INSPECTION

1. 15 INCH TYPE

Check the pad thickness A.

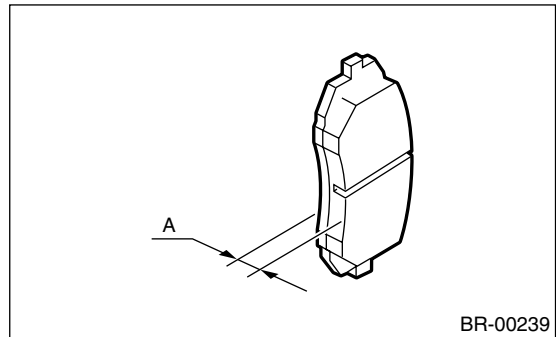

Pad thickness	Standard value	11 mm (0.43 in)
	Wear limit	1.5 mm (0.059 in)

NOTE:

- Always replace the pads for both right and left wheels at the same time.
- Also replace the pad clips if they are twisted or worn.
- A wear indicator is provided on the inner disc brake pad. If the pad wears down to such an extent that the end of wear indicator contacts disc rotor, a squeaking sound is produced as the wheel rotates. If this sound is heard, replace the pad.
- Replace the pad if there is oil or grease on it.

2. 16 INCH TYPE

- Replace the pad if there is oil or grease on it.

Check the pad thickness A.

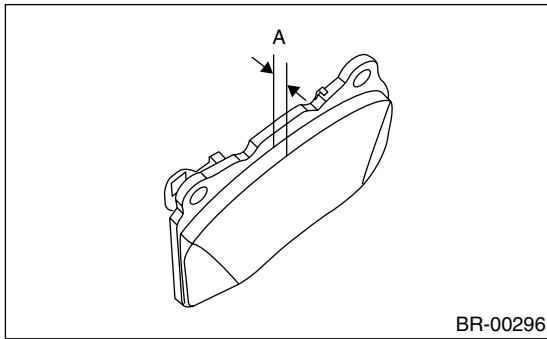

Pad thickness	Standard value	11 mm (0.43 in)
	Wear limit	1.5 mm (0.59 in)

NOTE:

- Always replace the pads for both right and left wheels at the same time.
- Also replace the pad clips if they are twisted or worn.
- A wear indicator is provided on the inner disc brake pad. If the pad wears down to such an extent that the end of wear indicator contacts disc rotor, a squeaking sound is produced as the wheel rotates. If this sound is heard, replace the pad.
- Replace the pad if there is oil or grease on it.

3. 17 INCH TYPE

Check the pad thickness A.

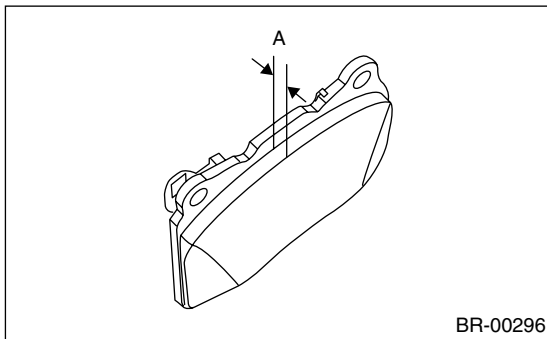

Pad thickness	Standard value	9.2 mm (0.362 in)
	Wear limit	1.2 mm (0.047 in)

NOTE:

- Always replace the pads for both right and left wheels at the same time.
- Also replace the pad clips if they are twisted or worn.
- A wear indicator is provided on the inner disc brake pad. If the pad wears down to such an extent that the end of wear indicator contacts disc rotor, a squeaking sound is produced as the wheel rotates. If this sound is heard, replace the pad.