

6. Rear Disc Rotor

A: REMOVAL

- 1) Set the vehicle on a lift.
- 2) Loosen the wheel nuts.
- 3) Lift-up the vehicle, and then remove the wheels.
- 4) Pull down and release the parking brake.
- 5) Remove the two mounting bolts, and then remove the disc brake assembly.

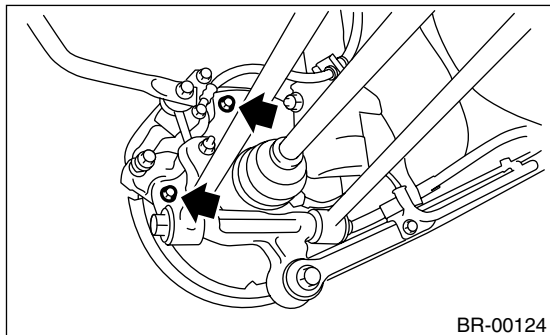

BR-00124

- 6) Suspend the disc brake assembly so that hose is not stretched.
- 7) Remove the disc rotor.

NOTE:

If the disc rotor is difficult to remove try following two methods in order.

- (1) Turn the adjusting screw using a flat tip screwdriver until brake shoe gets away enough from the disc rotor.

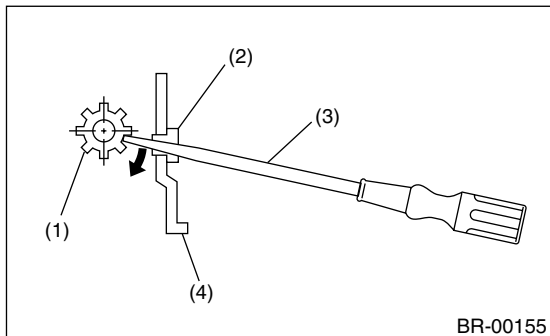

BR-00155

- (1) Adjusting screw
- (2) Cover
- (3) Flat tip screwdriver
- (4) Back plate

- (2) If the disc rotor seizes up within hub, drive the disc rotor out by installing an 8-mm bolt in holes B on rotor.

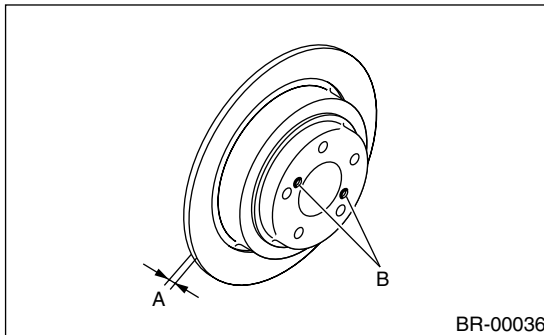

BR-00036

B: INSTALLATION

- 1) Install in the reverse order of removal.
- 2) Adjust the parking brake. <Ref. to PB-8, ADJUSTMENT, Parking Brake Assembly (Rear Disc Brake).>

C: INSPECTION

- 1) Check bearing axial end play and hub runout before disc rotor runout limit inspection. <Ref. to DS-28, INSPECTION, Rear Axle.>
- 2) Secure the disc rotor by tightening five wheel nuts.
- 3) Set a dial gauge 10 mm (0.39 in) inward of rotor outer perimeter. Turn the disc rotor to check runout. If the disc rotor runout is above specified value, replace the disc rotor.

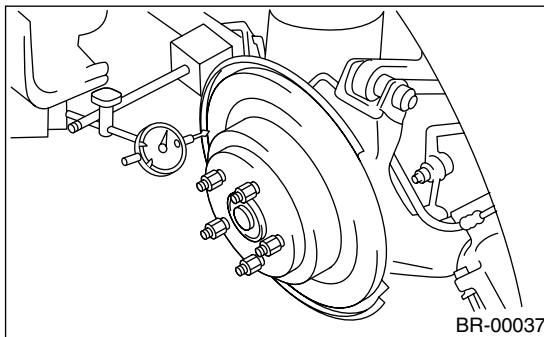

BR-00037

**Disc rotor runout limit:
0.070 mm (0.0027 in)**

REAR DISC ROTOR

4) Set a micrometer 10 mm (0.39 in) inward of the rotor outer perimeter, and then measure the disc rotor thickness. If the thickness of disc rotor is outside the service limit, replace the disc rotor.

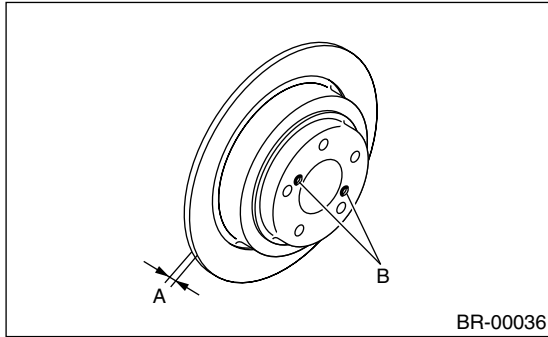

BR-00036

		Standard value	Service limit	Disc outer dia.
Disc rotor thickness A	14"	10 mm (0.39 in)	8.5 mm (0.335 in)	266 mm (10.47 in)
	17"	20 mm (0.79 in)	18 mm (0.71 in)	316 mm (12.44 in)