

STOP LIGHT SWITCH

BRAKE

15. Stop Light Switch

A: REMOVAL

- 1) Disconnect the ground cable from battery.
- 2) Disconnect the stop light switch connector.
- 3) Loosen nuts, and unscrew stop light switch to remove.

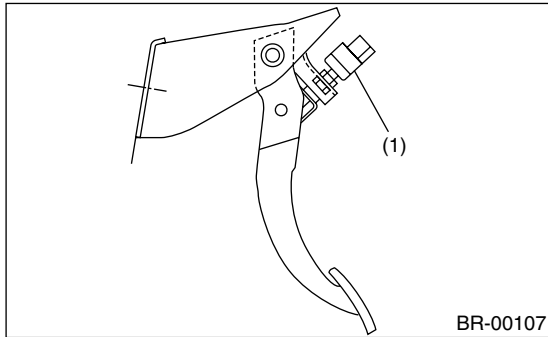

(1) Stop light switch

B: INSTALLATION

- 1) Screw the stop light switch onto a bracket and secure it temporarily with a nut.
 - 2) Adjust the stop light switch position, and then tighten the nut.
- <Ref. to BR-53, ADJUSTMENT, Stop Light Switch.>

Tightening torque:

8 N·m (0.8 kgf·m, 5.8 ft·lb)

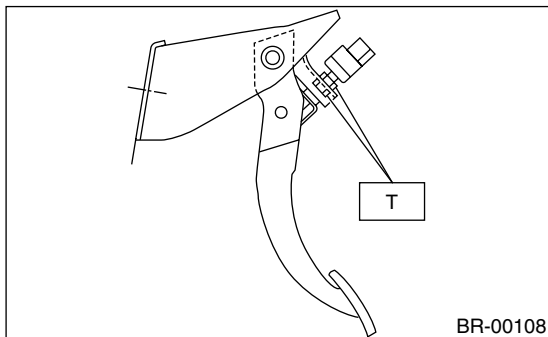

C: INSPECTION

- 1) If the stop light switch does not operate properly (or if it does not stop at the specified position), replace with a new one.

Specified position: L
2 mm (0.079 in)

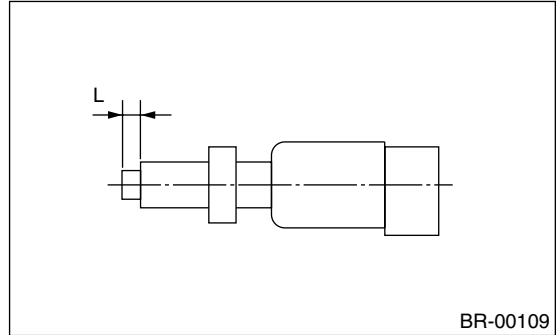

- 2) Measure the clearance between threaded end of stop light switch and stopper.

CAUTION:

Be careful not to rotate stop light switch.

Stop light switch clearance: A
0.3 mm (0.012 in)

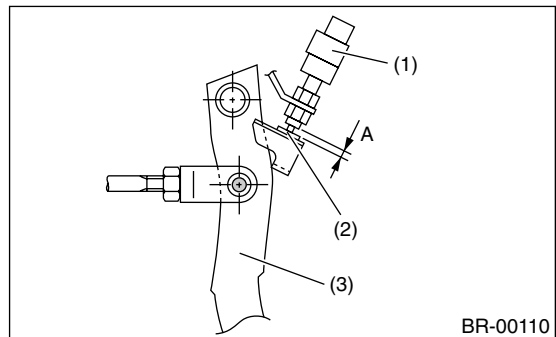

- (1) Stop light switch
- (2) Stopper
- (3) Brake pedal

- 3) If it is not within specified value, adjust it by adjusting position of stop light switch.

CAUTION:

Be careful not to rotate the stop light switch.

D: ADJUSTMENT

Loosen the lock nut, and adjust the stop light switch position until the clearance between threaded end of stop light switch and stopper (A) becomes 0.3 mm (0.012 in). Then, tighten the lock nut.

Tightening torque:

8 N·m (0.8 kgf·m, 5.8 ft·lb)

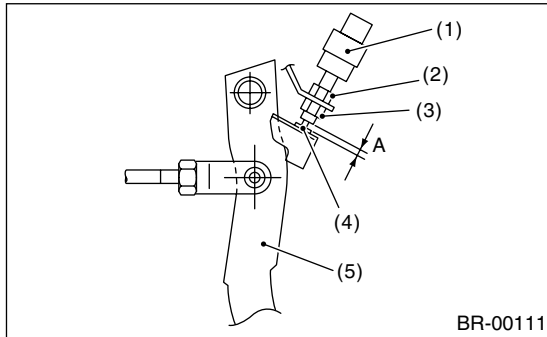

- (1) Stop light switch
- (2) Lock nut A
- (3) Lock nut B
- (4) Stopper
- (5) Brake pedal

NOTE:

Tighten the lock nut B until the clearance between threaded end of stop light switch and stopper becomes 0 mm (0 in). Hold the stop light switch to prevent turning, and then loosen the lock nut B approx. 60°. The clearance (A) will become 0.3 mm (0.012 in).