

22.High-mounted Stop Light

A: REMOVAL

1. SEDAN (STANDARD TYPE)

- 1) Disconnect the ground cable from battery.
- 2) Disconnect the connector of high-mounted stop light from body harness.
- 3) Remove the bolts, then detach the high-mounted stop light assembly.

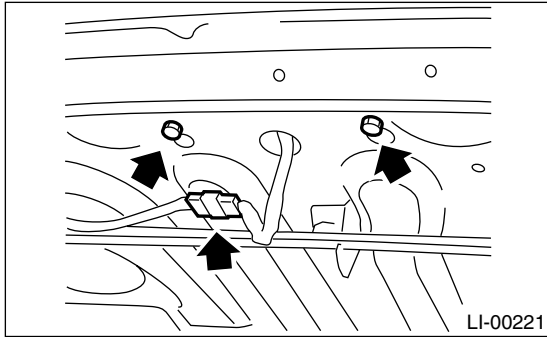

2. SEDAN (REAR SPOILER BUILT-IN TYPE)

- 1) Disconnect the ground cable from battery.
- 2) Remove the bolts, then detach the high-mounted stop light assembly.
- 3) Disconnect the connector of high-mounted stop light from body harness.

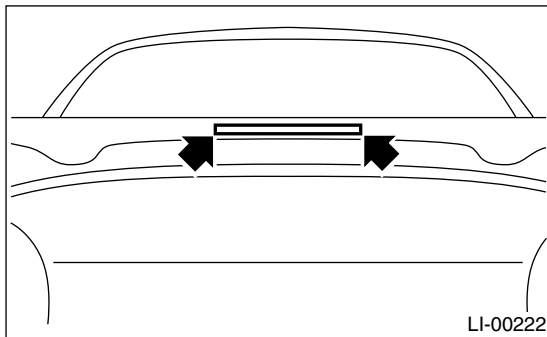

3. WAGON

- 1) Disconnect the ground cable from battery.
- 2) Remove the cap (a) by prying on the edge with screwdriver.
- 3) Remove the screws (b), and then the detach cover (c).

- 4) Remove screws (d), and then detach the high-mounted stop light while disconnecting connector.

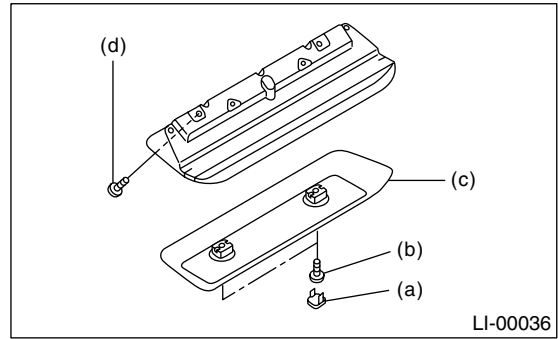

B: INSTALLATION

Install in the reverse order of removal.

C: INSPECTION

- 1) Visually check the bulb for blow out.
- 2) Check the bulb specification. <Ref. to LI-2, SPECIFICATIONS, General Description.>
- 3) If NG, replace the bulb with a new one.