

# DIAGNOSTIC PROCEDURE WITH SYMPTOM

## CRUISE CONTROL SYSTEM (DIAGNOSTICS)

### 6. Diagnostic Procedure with Symptom

#### A: SYMPTOM CHART

| Symptom |   | Repair area                                       | Reference   |
|---------|---|---|---|
| 1       | Cruise control main switch is not turned to ON.   | (1) Check the power supply.                       | <Ref. to CC-12, CHECK POWER SUPPLY, Diagnostic Procedure with Symptom.>                       |
|         |   | (2) Check the cruise control main switch.         | <Ref. to CC-14, CHECK CRUISE CONTROL MAIN SWITCH, Diagnostic Procedure with Symptom.>         |
| 2       | Cruise indicator light does not illuminate.   | (1) Check the cruise indicator light.             | <Ref. to CC-16, CHECK CRUISE INDICATOR LIGHT, Diagnostic Procedure with Symptom.>             |
|         |   | (2) Check the cruise set indicator light.         | <Ref. to CC-18, CHECK CRUISE SET INDICATOR LIGHT, Diagnostic Procedure with Symptom.>         |
| 3       | Cruise control cannot be set.   | (1) Check the SET/COAST switch.                   | <Ref. to CC-20, CHECK CRUISE CONTROL COMMAND SWITCH, Diagnostic Procedure with Symptom.>      |
|         |   | (2) Check the stop light switch and brake switch. | <Ref. to CC-22, CHECK STOP LIGHT SWITCH AND BRAKE SWITCH, Diagnostic Procedure with Symptom.> |
|         |   | (3) Check the clutch switch (MT model).           | <Ref. to CC-24, CHECK CLUTCH SWITCH (MT MODEL), Diagnostic Procedure with Symptom.>           |
|         |   | (4) Check the inhibitor switch (AT model).        | <Ref. to CC-26, CHECK INHIBITOR SWITCH (AT MODEL), Diagnostic Procedure with Symptom.>        |
|         |   | (5) Check the vehicle speed sensor.               | <Ref. to CC-30, DTC 22 VEHICLE SPEED SENSOR, Diagnostic Procedure with DTC.>                  |
|         |   | (6) Check the motor drive system.                 | <Ref. to CC-33, DTC 35 AND 36 ACTUATOR MOTOR, Diagnostic Procedure with DTC.>                 |
|         |   | (7) Check the motor clutch drive system.          | <Ref. to CC-35, DTC 37 ACTUATOR MOTOR CLUTCH, Diagnostic Procedure with DTC.>                 |
| 4       | Vehicle speed is not held within set speed $\pm 3$ km/h ( $\pm 2$ MPH).                                     | (1) Check the vehicle speed sensor.               | <Ref. to CC-30, DTC 22 VEHICLE SPEED SENSOR, Diagnostic Procedure with DTC.>                  |
|         |   | (2) Check the motor drive system.                 | <Ref. to CC-33, DTC 35 AND 36 ACTUATOR MOTOR, Diagnostic Procedure with DTC.>                 |
|         |   | (3) Check the motor clutch drive system.          | <Ref. to CC-35, DTC 37 ACTUATOR MOTOR CLUTCH, Diagnostic Procedure with DTC.>                 |
| 5       | Vehicle speed does not increase or does not return to set speed after RESUME/ACCEL switch has been pressed. | (1) Check the RESUME/ACCEL switch.                | <Ref. to CC-20, CHECK CRUISE CONTROL COMMAND SWITCH, Diagnostic Procedure with Symptom.>      |
|         |   | (2) Check the motor drive system.                 | <Ref. to CC-33, DTC 35 AND 36 ACTUATOR MOTOR, Diagnostic Procedure with DTC.>                 |
|         |   | (3) Check the motor clutch drive system.          | <Ref. to CC-35, DTC 37 ACTUATOR MOTOR CLUTCH, Diagnostic Procedure with DTC.>                 |
| 6       | Vehicle speed does not decrease after SET/COAST switch has been pressed.                                    | (1) Check the SET/COAST switch.                   | <Ref. to CC-20, CHECK CRUISE CONTROL COMMAND SWITCH, Diagnostic Procedure with Symptom.>      |
|         |   | (2) Check the motor drive system.                 | <Ref. to CC-33, DTC 35 AND 36 ACTUATOR MOTOR, Diagnostic Procedure with DTC.>                 |
|         |   | (3) Check the motor clutch drive system.          | <Ref. to CC-35, DTC 37 ACTUATOR MOTOR CLUTCH, Diagnostic Procedure with DTC.>                 |
| 7       | Cruise control is not released after CANCEL switch has been pressed.  | (1) Check the CANCEL switch.                      | <Ref. to CC-20, CHECK CRUISE CONTROL COMMAND SWITCH, Diagnostic Procedure with Symptom.>      |
|         |   | (2) Check the motor drive system.                 | <Ref. to CC-33, DTC 35 AND 36 ACTUATOR MOTOR, Diagnostic Procedure with DTC.>                 |
|         |   | (3) Check the motor clutch drive system.          | <Ref. to CC-35, DTC 37 ACTUATOR MOTOR CLUTCH, Diagnostic Procedure with DTC.>                 |
| 8       | Cruise control is not released after brake pedal has been depressed.  | (1) Check the stop light switch and brake switch. | <Ref. to CC-22, CHECK STOP LIGHT SWITCH AND BRAKE SWITCH, Diagnostic Procedure with Symptom.> |
|         |   | (2) Check the motor drive system.                 | <Ref. to CC-33, DTC 35 AND 36 ACTUATOR MOTOR, Diagnostic Procedure with DTC.>                 |
|         |   | (3) Check the motor clutch drive system.          | <Ref. to CC-35, DTC 37 ACTUATOR MOTOR CLUTCH, Diagnostic Procedure with DTC.>                 |

# DIAGNOSTIC PROCEDURE WITH SYMPTOM

## CRUISE CONTROL SYSTEM (DIAGNOSTICS)

| Symptom |  | Repair area                              | Reference   |
|---------|--|--|---|
| 9       | Cruise control is not released after clutch pedal has been depressed (MT model). | (1) Check the clutch switch.             | <Ref. to CC-24, CHECK CLUTCH SWITCH (MT MODEL), Diagnostic Procedure with Symptom.> |
|         |  | (2) Check the motor drive system.        | <Ref. to CC-33, DTC 35 AND 36 ACTUATOR MOTOR, Diagnostic Procedure with DTC.>       |
|         |  | (3) Check the motor clutch drive system. | <Ref. to CC-35, DTC 37 ACTUATOR MOTOR CLUTCH, Diagnostic Procedure with DTC.>       |

# DIAGNOSTIC PROCEDURE WITH SYMPTOM

## CRUISE CONTROL SYSTEM (DIAGNOSTICS)

### B: CHECK POWER SUPPLY

#### TROUBLE SYMPTOM:

Cruise control is not turned to ON.

#### WIRING DIAGRAM:

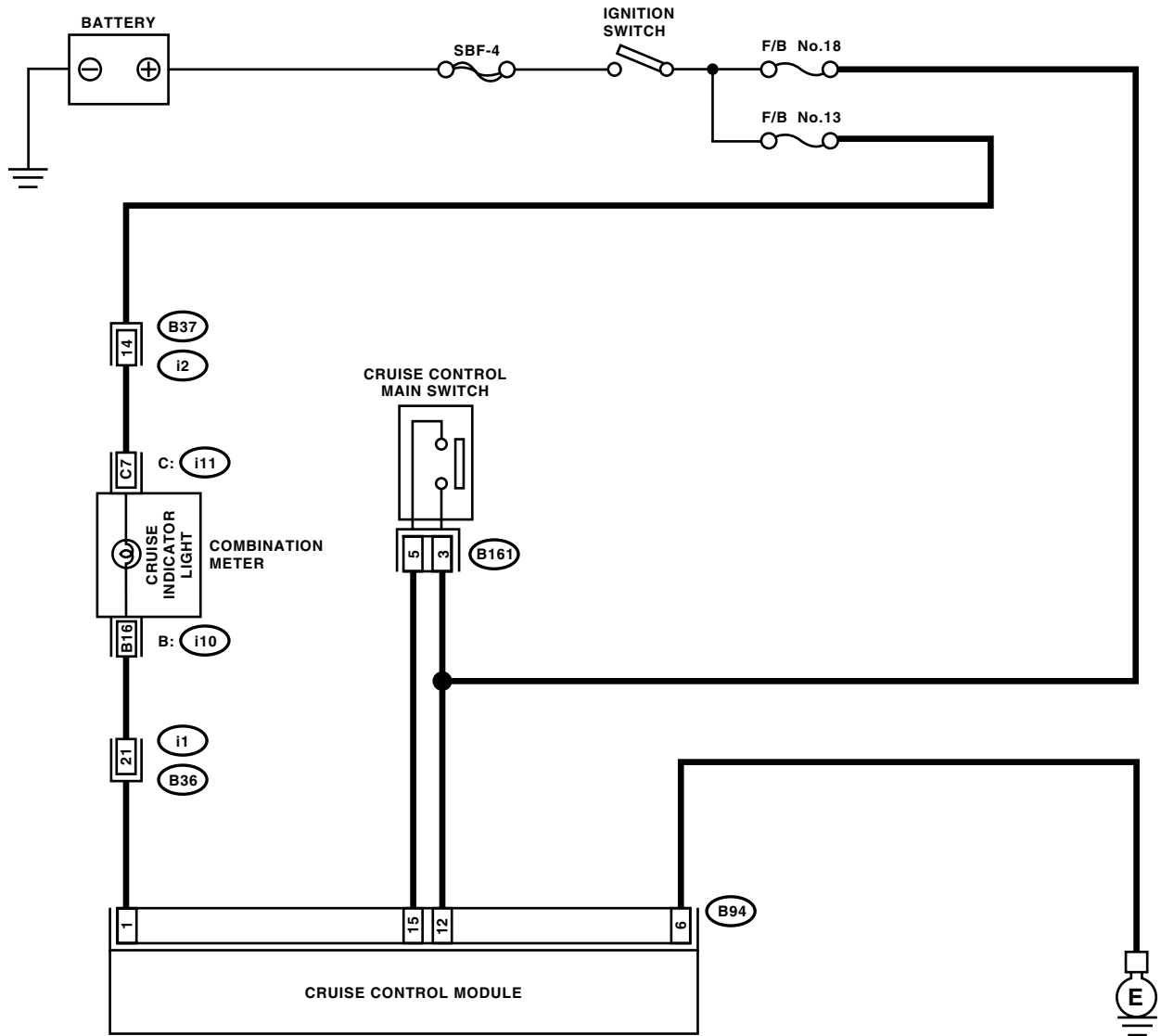

B161



B94

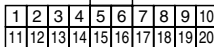

i1

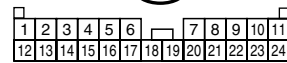

i2

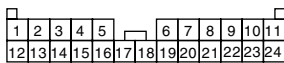

B: i10

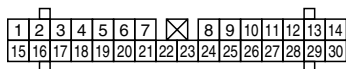

c: i11

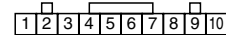

CC-00187

# DIAGNOSTIC PROCEDURE WITH SYMPTOM

## CRUISE CONTROL SYSTEM (DIAGNOSTICS)

| Step   | Check                                     | Yes                                     | No   |
|--|---|---|--|
| <b>1</b><br><b>CHECK POWER SUPPLY.</b><br>1) Turn the ignition switch to OFF.<br>2) Disconnect the cruise control module harness connector.<br>3) Turn the ignition switch to ON.<br>4) Measure the voltage between harness connector terminal and chassis ground.<br><b>Connector &amp; terminal</b><br><b>(B94) No. 12 (+) — Chassis ground (-):</b> | Is the voltage more than 10 V?            | Go to step 2.                           | <ul style="list-style-type: none"><li>• Check the fuse No. 18 (in fuse &amp; relay box).</li><li>• Check the harness for open or short between cruise control module and fuse &amp; relay box.</li></ul> |
| <b>2</b><br><b>CHECK GROUND CIRCUIT.</b><br>1) Turn the ignition switch to OFF.<br>2) Measure the resistance between harness connector terminal and chassis ground.<br><b>Connector &amp; terminal</b><br><b>(B94) No. 6 — Chassis ground:</b>   | Is the resistance less than 10 $\Omega$ ? | Power supply and ground circuit are OK. | Repair the harness.  |

# DIAGNOSTIC PROCEDURE WITH SYMPTOM

## CRUISE CONTROL SYSTEM (DIAGNOSTICS)

### C: CHECK CRUISE CONTROL MAIN SWITCH

#### TROUBLE SYMPTOM:

Cruise control main switch is not turned to ON and cruise control cannot be set.

#### NOTE:

When the main relay (built-in cruise control module) operates, the main switch circuit is in normal condition. The main relay operation can be checked by hearing the operation sound.

This operation sound will be heard when the ignition switch and cruise control main switch is turned to ON.

#### WIRING DIAGRAM:

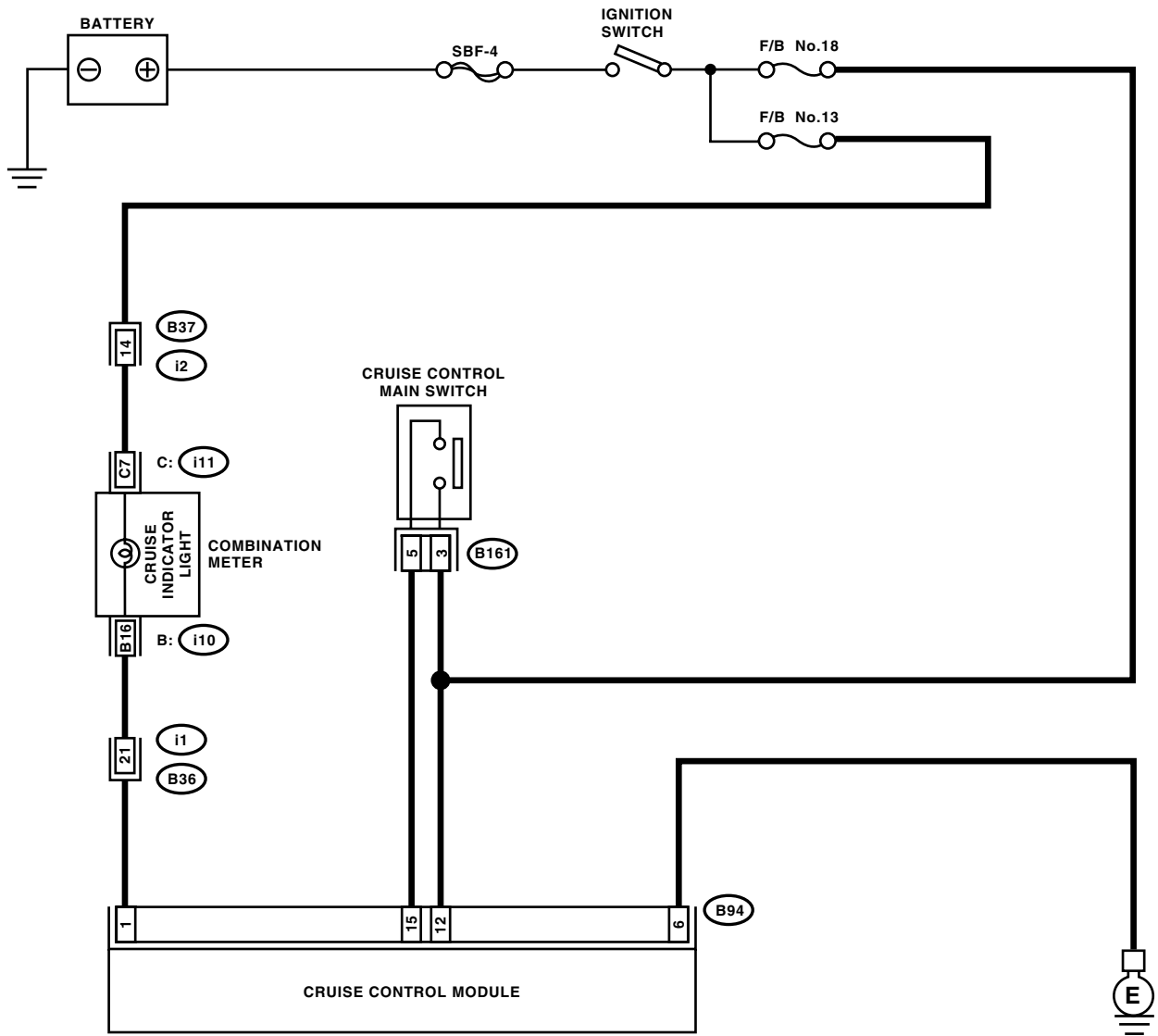

B161



B94

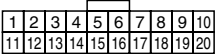

i1

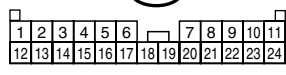

i2

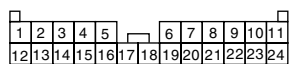

B: i10



C: i11

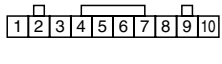

# DIAGNOSTIC PROCEDURE WITH SYMPTOM

## CRUISE CONTROL SYSTEM (DIAGNOSTICS)

| Step  | Check                                     | Yes                                | No   |
|---|---|------------------------------------|--|
| <b>1 CHECK CRUISE CONTROL MAIN SWITCH CIRCUIT.</b><br>1) Turn the ignition switch to OFF.<br>2) Disconnect the cruise control main switch harness connector.<br>3) Turn the ignition switch to ON.<br>4) Measure the voltage between harness connector terminal and chassis ground.<br><i><b>Connector &amp; terminal</b></i><br><i><b>(B161) No. 3 (+) — Chassis ground (-):</b></i>         | Is the voltage more than 10 V?            | Go to step 2.                      | <ul style="list-style-type: none"> <li>• Check the fuse No. 18 (in fuse &amp; relay box).</li> <li>• Check the harness for open or short between cruise control main switch and fuse &amp; relay box.</li> </ul> |
| <b>2 CHECK CRUISE CONTROL MAIN SWITCH CIRCUIT.</b><br>1) Turn the ignition switch OFF.<br>2) Disconnect the cruise control module harness connector.<br>3) Measure the resistance between cruise control module harness connector terminal and cruise control main switch harness connector terminal.<br><i><b>Connector &amp; terminal</b></i><br><i><b>(B94) No. 15 — (B161) No. 5:</b></i> | Is the resistance less than 10 $\Omega$ ? | Go to step 3.                      | Repair the harness.  |
| <b>3 CHECK CRUISE CONTROL MAIN SWITCH.</b><br>Remove and check the cruise control main switch. <Ref. to CC-6, Cruise Control Main Switch.>  | Is the cruise control main switch OK?     | Replace the cruise control module. | Replace the cruise control main switch.  |

# DIAGNOSTIC PROCEDURE WITH SYMPTOM

## CRUISE CONTROL SYSTEM (DIAGNOSTICS)

### D: CHECK CRUISE INDICATOR LIGHT

#### TROUBLE SYMPTOM:

Cruise control can be set, but cruise indicator light does not illuminate.

#### WIRING DIAGRAM:

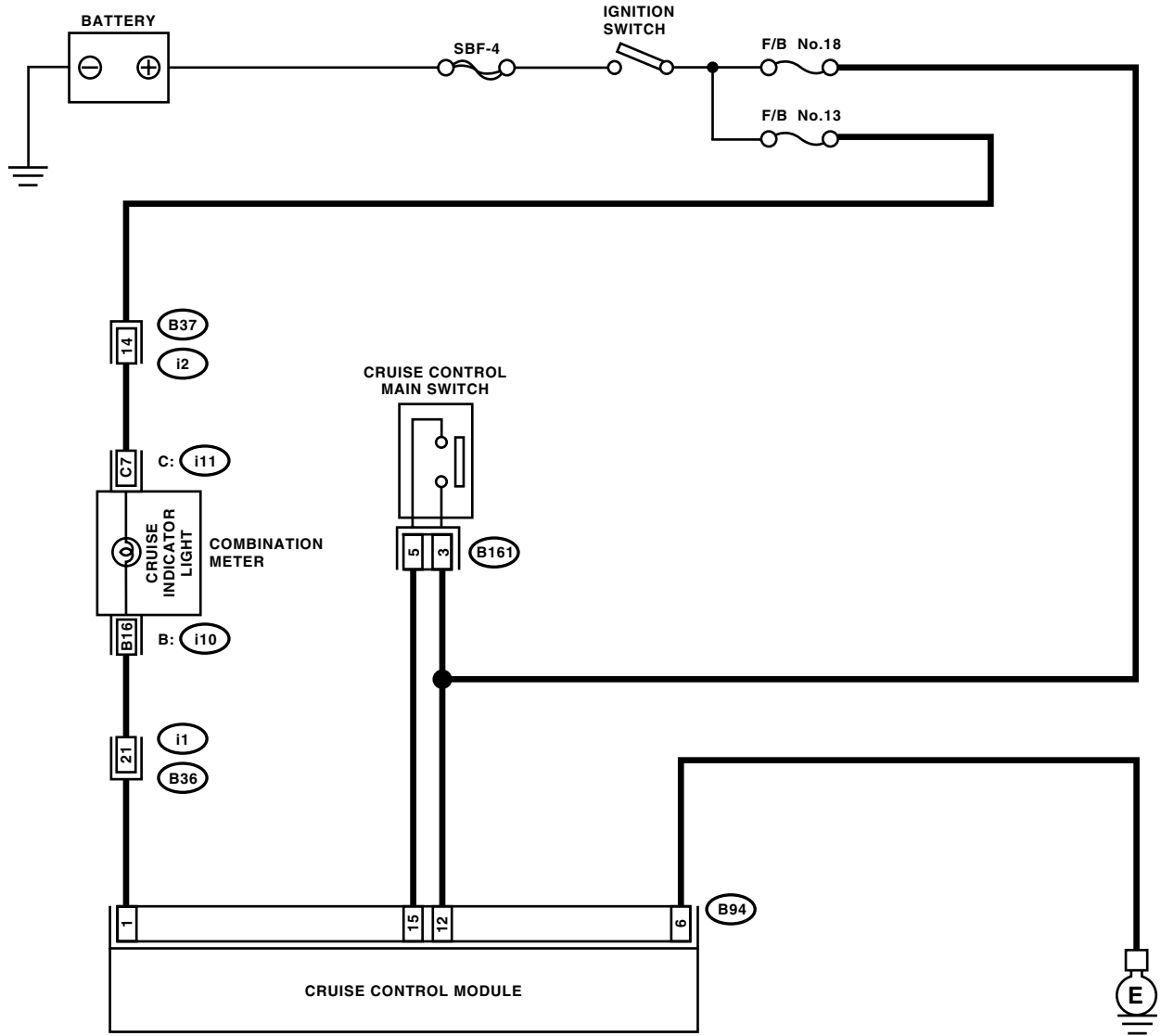

B161



B94

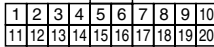

I1

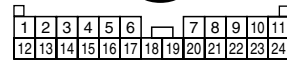

I2

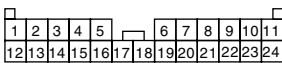

B: I10

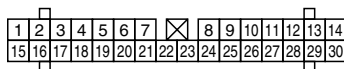

C: I11

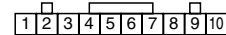

CC-00187

# DIAGNOSTIC PROCEDURE WITH SYMPTOM

## CRUISE CONTROL SYSTEM (DIAGNOSTICS)

| Step   | Check  | Yes                                       | No  |
|--|--|---|---|
| <p><b>1</b></p> <p><b>CHECK CRUISE INDICATOR LIGHT CIRCUIT.</b></p> <p>1) Turn the ignition switch to OFF.<br/>                     2) Disconnect the combination meter harness connector.<br/>                     3) Turn the ignition switch to ON.<br/>                     4) Measure the voltage between harness connector terminal and chassis ground.</p> <p><b>Connector &amp; terminal</b><br/> <i>(i11) No. 7 (+) — Chassis ground (-):</i></p> | <p>Is the voltage more than 10 V?</p>                      | <p>Go to step 2.</p>                      | <ul style="list-style-type: none"> <li>• Check the fuse No. 13 (in fuse &amp; relay box).</li> <li>• Check the harness for open or short between combination meter and fuse &amp; relay box.</li> </ul>     |
| <p><b>2</b></p> <p><b>CHECK CRUISE INDICATOR LIGHT CIRCUIT.</b></p> <p>1) Turn the ignition switch to OFF.<br/>                     2) Disconnect the cruise control module harness connector.<br/>                     3) Measure the resistance between cruise control module harness connector terminal and combination meter harness connector terminal.</p> <p><b>Connector &amp; terminal</b><br/> <i>(B94) No. 1 — (i10) No. 16:</i></p>            | <p>Is the resistance less than 10 <math>\Omega</math>?</p> | <p>Go to step 3.</p>                      | <p>Repair the harness.</p>  |
| <p><b>3</b></p> <p><b>CHECK CRUISE INDICATOR LIGHT CIRCUIT.</b></p> <p>Ground the cruise control module harness connector terminal with a suitable wire.</p> <p><b>Connector &amp; terminal</b><br/> <i>(B94) No. 1 — Chassis ground:</i></p>  | <p>Does the cruise indicator light illuminate?</p>         | <p>Replace the cruise control module.</p> | <p>Check the cruise indicator light bulb in combination meter, and replace it if malfunction occurred.<br/>                     No malfunction found, replace the printed circuit of combination meter.</p> |



# DIAGNOSTIC PROCEDURE WITH SYMPTOM

## CRUISE CONTROL SYSTEM (DIAGNOSTICS)

### E: CHECK CRUISE SET INDICATOR LIGHT

#### TROUBLE SYMPTOM:

Cruise control can be set, but cruise set indicator light does not illuminate.

#### WIRING DIAGRAM:

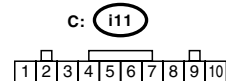
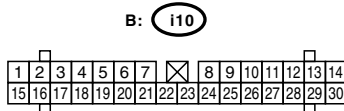
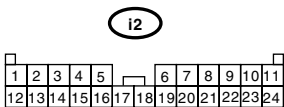
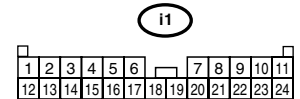
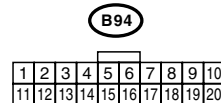
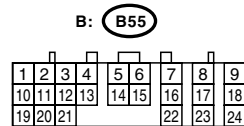
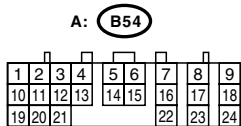
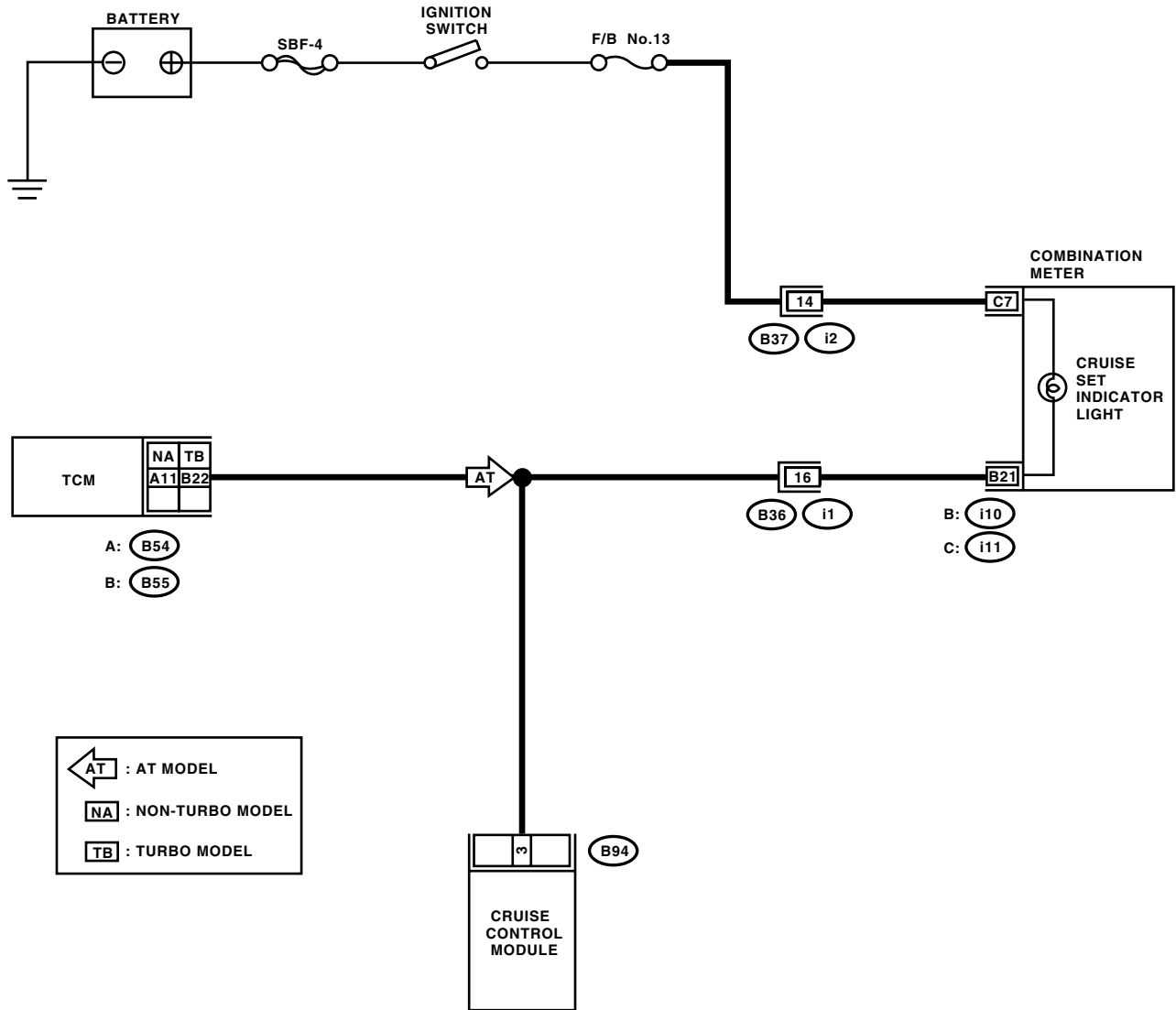

CC-00191

# DIAGNOSTIC PROCEDURE WITH SYMPTOM

## CRUISE CONTROL SYSTEM (DIAGNOSTICS)

| Step   | Check   | Yes                                | No  |
|--|---|------------------------------------|---|
| <b>1</b><br><b>CHECK CRUISE SET INDICATOR LIGHT CIRCUIT.</b><br>1) Turn the ignition switch to OFF.<br>2) Disconnect the combination meter harness connector.<br>3) Measure the voltage between harness connector terminal and chassis ground.<br><i><b>Connector &amp; terminal</b></i><br><i><b>(i11) No. 7 (+) — Chassis ground (-):</b></i>  | Is the voltage more than 10 V?                  | Go to step 2.                      | <ul style="list-style-type: none"> <li>• Check the fuse No. 13 (in fuse &amp; relay box).</li> <li>• Check the harness for open or short between combination meter and fuse &amp; relay box.</li> </ul> |
| <b>2</b><br><b>CHECK CRUISE SET INDICATOR LIGHT CIRCUIT.</b><br>1) Turn the ignition switch to OFF.<br>2) Disconnect the cruise control module harness connector.<br>3) Measure the resistance between cruise control module harness connector terminal and combination meter harness connector terminal.<br><i><b>Connector &amp; terminal</b></i><br><i><b>(i10) No. 21 — (B94) No. 3:</b></i> | Is the resistance less than 10 $\Omega$ ?       | Go to step 3.                      | Repair the harness.   |
| <b>3</b><br><b>CHECK CRUISE SET INDICATOR LIGHT CIRCUIT.</b><br>Ground the cruise control module harness connector terminal with a suitable wire.<br><i><b>Connector &amp; terminal</b></i><br><i><b>(B94) No. 3 — Chassis ground:</b></i>   | Does the cruise set indicator light illuminate? | Replace the cruise control module. | Check the cruise set indicator light bulb in combination meter, and replace it if malfunction occurred. No malfunction found, replace the printed circuit of combination meter.                         |

# DIAGNOSTIC PROCEDURE WITH SYMPTOM

## CRUISE CONTROL SYSTEM (DIAGNOSTICS)

### F: CHECK CRUISE CONTROL COMMAND SWITCH

#### TROUBLE SYMPTOM:

Cruise control cannot be set. (Cancelled immediately.)

#### WIRING DIAGRAM:

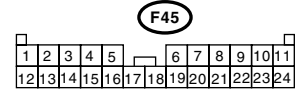
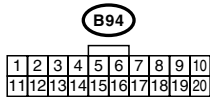
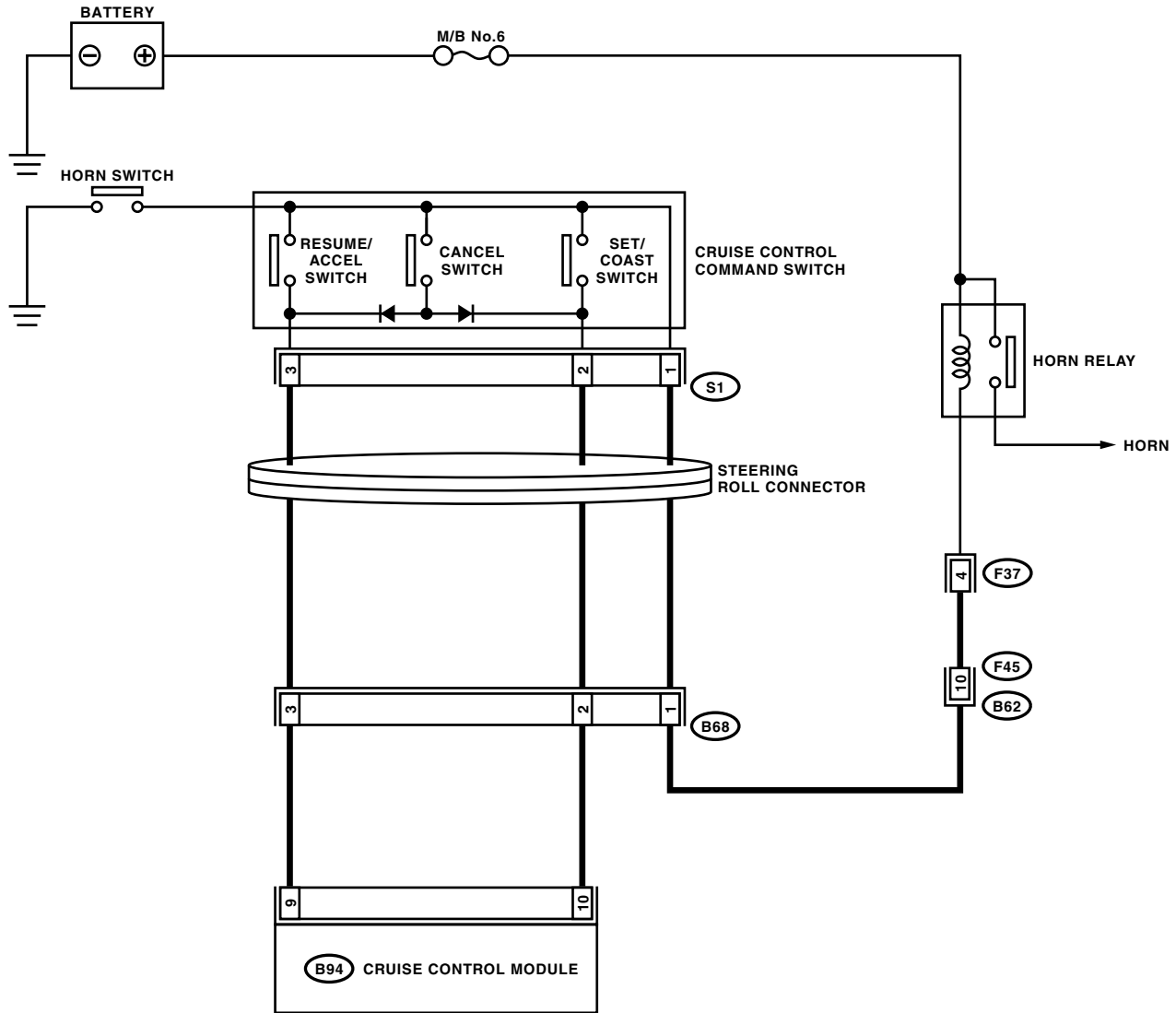

# DIAGNOSTIC PROCEDURE WITH SYMPTOM

## CRUISE CONTROL SYSTEM (DIAGNOSTICS)

| Step  | Check  | Yes  | No   |
|---|--|--|--|
| <b>1 CHECK SET/COAST SWITCH CIRCUIT.</b><br>1) Turn the ignition switch to OFF.<br>2) Disconnect the cruise control module harness connector.<br>3) Measure the voltage between harness connector terminal and chassis ground when SET/COAST switch is pressed and not pressed.<br><b>Connector &amp; terminal</b><br><b>(B94) No. 10 (+) — Chassis ground (-):</b> | Is the voltage 0 V when SET/COAST switch is not pressed?<br>Is the voltage more than 10 V when SET/COAST switch is pressed?    | Go to step 2.  | Go to step 4.  |
| <b>2 CHECK RESUME/ACCEL SWITCH CIRCUIT.</b><br>Measure the voltage between harness connector terminal and chassis ground when RESUME/ACCEL switch is pressed and not pressed.<br><b>Connector &amp; terminal</b><br><b>(B94) No. 9 (+) — Chassis ground (-):</b>  | Is the voltage 0 V when RESUME/ACCEL switch is not pressed? Is the voltage more than 10 V when RESUME/ACCEL switch is pressed? | Go to step 3.  | Go to step 4.  |
| <b>3 CHECK CANCEL SWITCH CIRCUIT.</b><br>Measure the voltage between harness connector terminal and chassis ground when CANCEL switch is pressed and not pressed.<br><b>Connector &amp; terminal</b><br><b>(B94) No. 9 (+) — Chassis ground (-):</b><br><b>(B94) No. 10 (+) — Chassis ground (-):</b>   | Is the voltage 0 V when CANCEL switch is not pressed? Is the voltage more than 10 V when CANCEL switch is pressed?             | Cruise control command switch circuit is OK.                                       | Go to step 4.  |
| <b>4 CHECK POWER SUPPLY FOR COMMAND SWITCH.</b><br>Check the horn operation.  | Does the horn sound?   | Go to step 5.  | <ul style="list-style-type: none"> <li>• Check the fuse No. 6 (in main fuse box).</li> <li>• Check the horn relay. &lt;Ref. to COM-3, HORN RELAY, INSPECTION, Horn System.&gt;</li> <li>• Check the harness for open or short between cruise control command switch and fuse &amp; relay box.</li> </ul> |
| <b>5 CHECK CRUISE CONTROL COMMAND SWITCH.</b><br>Remove and check the cruise control command switch. <Ref. to CC-7, Cruise Control Command Switch.>   | Is the cruise control command switch OK?   | Check the harness between cruise control command switch and cruise control module. | Replace the cruise control command switch.   |

# DIAGNOSTIC PROCEDURE WITH SYMPTOM

## CRUISE CONTROL SYSTEM (DIAGNOSTICS)

### G: CHECK STOP LIGHT SWITCH AND BRAKE SWITCH

#### TROUBLE SYMPTOM:

Cruise control cannot be set.

#### WIRING DIAGRAM:

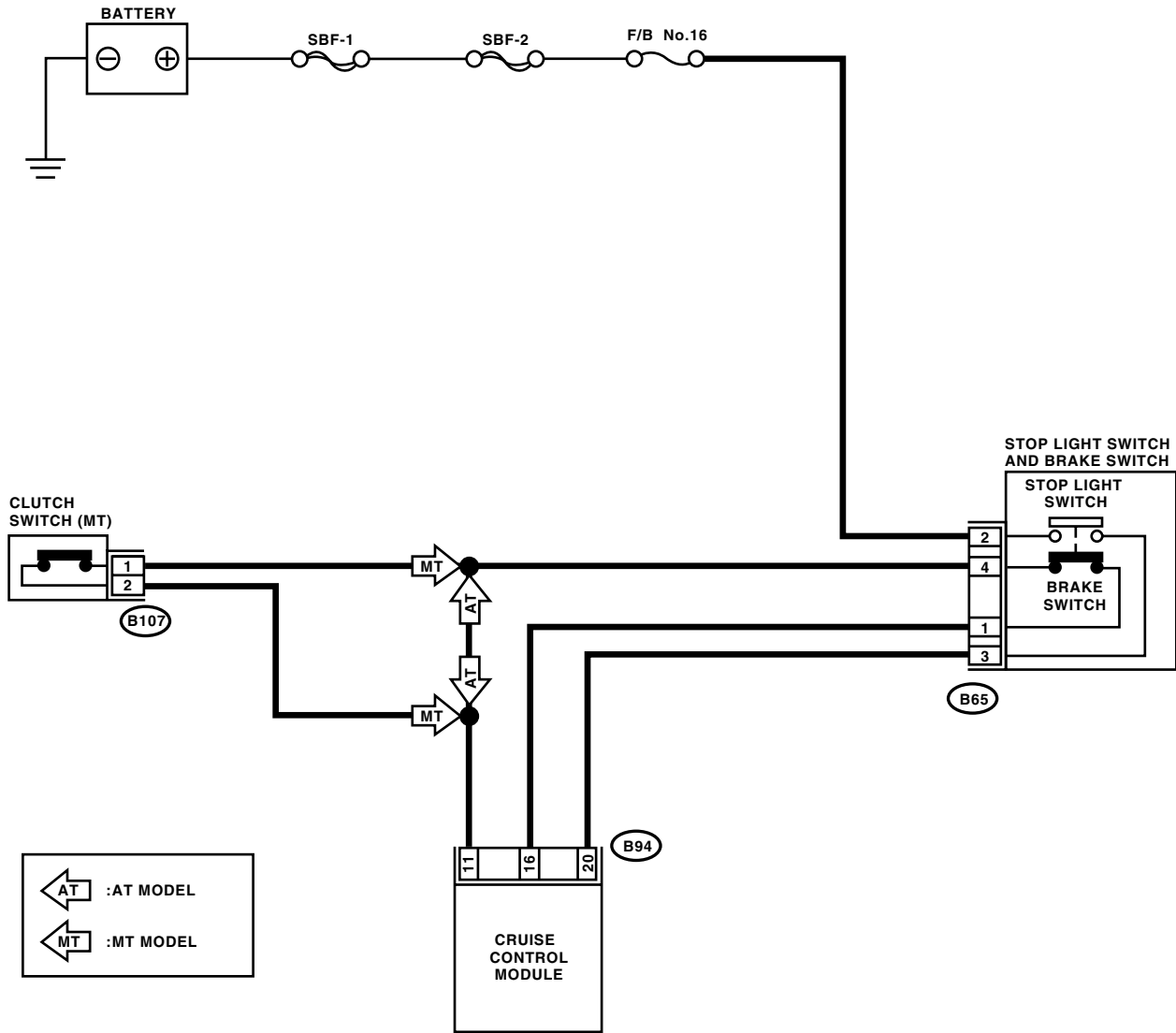

(B107)



(B65)



(B94)

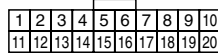

# DIAGNOSTIC PROCEDURE WITH SYMPTOM

## CRUISE CONTROL SYSTEM (DIAGNOSTICS)

| Step  | Check  | Yes  | No   |
|---|--|--|--|
| <b>1</b><br><b>CHECK STOP LIGHT SWITCH AND BRAKE SWITCH CIRCUIT.</b><br>1) Turn the ignition switch to OFF.<br>2) Disconnect the stop light switch and brake switch harness connector.<br>3) Turn the ignition switch to ON.<br>4) Turn the cruise control main switch to ON.<br>5) Measure the voltage between harness connector terminal and chassis ground.<br><i><b>Connector &amp; terminal</b></i><br><i><b>(B65) No. 2 (+) — Chassis ground (-):</b></i>                                       | Is the voltage more than 10 V?                 | Go to step 2.                                      | <ul style="list-style-type: none"> <li>• Check the fuse No. 16 (in fuse &amp; relay box).</li> <li>• Check the harness for open or short between stop light/brake switch and fuse &amp; relay box.</li> </ul>            |
| <b>2</b><br><b>CHECK STOP LIGHT SWITCH AND BRAKE SWITCH CIRCUIT.</b><br>Measure the voltage between harness connector terminal and chassis ground.<br><i><b>Connector &amp; terminal</b></i><br><i><b>(B65) No. 4 (+) — Chassis ground (-):</b></i>   | Is the voltage more than 10 V?                 | Go to step 3.                                      | <ul style="list-style-type: none"> <li>• Check the harness for open or short between stop light/brake switch and cruise control module (AT model).</li> <li>• Check the clutch switch and circuit (MT model).</li> </ul> |
| <b>3</b><br><b>CHECK STOP LIGHT SWITCH AND BRAKE SWITCH CIRCUIT.</b><br>1) Turn the cruise control main switch and ignition switch to OFF.<br>2) Disconnect the cruise control module harness connector.<br>3) Measure the resistance between cruise control module harness connector terminal and stop light switch and brake switch harness connector terminal.<br><i><b>Connector &amp; terminal</b></i><br><i><b>(B94) No. 20 — (B65) No. 3:</b></i><br><i><b>(B94) No. 16 — (B65) No. 1:</b></i> | Is the resistance less than 10 $\Omega$ ?      | Go to step 4.                                      | Repair the harness.  |
| <b>4</b><br><b>CHECK STOP LIGHT SWITCH AND BRAKE SWITCH.</b><br>Remove and check the stop light switch and brake switch. <Ref. to CC-8, Stop and Brake Switch.>   | Are the stop light switch and brake switch OK? | Stop light switch and brake switch circuit are OK. | Replace the stop light switch and brake switch.  |

# DIAGNOSTIC PROCEDURE WITH SYMPTOM

## CRUISE CONTROL SYSTEM (DIAGNOSTICS)

### H: CHECK CLUTCH SWITCH (MT MODEL)

#### TROUBLE SYMPTOM:

Cruise control cannot be set.

#### WIRING DIAGRAM:

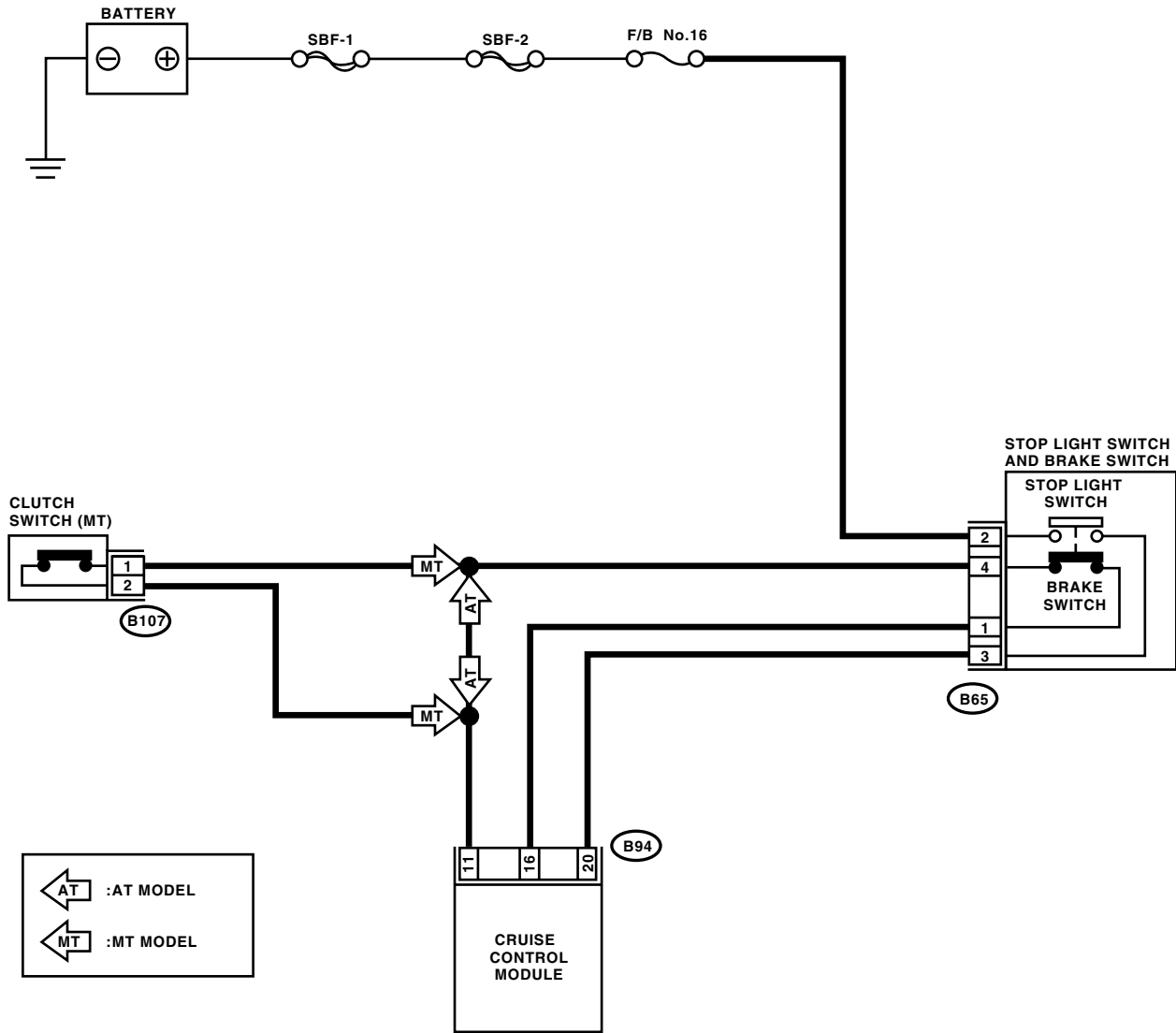

(B107)



(B65)



(B94)

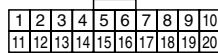

CC-00033

# DIAGNOSTIC PROCEDURE WITH SYMPTOM

## CRUISE CONTROL SYSTEM (DIAGNOSTICS)

| Step   | Check                                     | Yes                          | No   |
|--|---|------------------------------|--|
| <b>1</b><br><b>CHECK CLUTCH SWITCH CIRCUIT.</b><br>1) Turn the ignition switch to OFF.<br>2) Disconnect the clutch switch harness connector.<br>3) Turn the ignition switch to ON.<br>4) Turn the cruise control main switch to ON.<br>5) Measure the voltage between harness connector terminal and chassis ground.<br><b>Connector &amp; terminal</b><br><b>(B107) No. 2 (+) — Chassis ground (-):</b>                   | Is the voltage more than 10 V?            | Go to step 2.                | Check the harness for open or short between clutch switch and cruise control module. |
| <b>2</b><br><b>CHECK CLUTCH SWITCH CIRCUIT.</b><br>1) Turn the cruise control main switch and ignition switch to OFF.<br>2) Disconnect the stop light switch and brake switch harness connector.<br>3) Measure the resistance between clutch switch harness connector terminal and stop light switch and brake switch harness connector terminal.<br><b>Connector &amp; terminal</b><br><b>(B107) No. 1 — (B65) No. 4:</b> | Is the resistance less than 10 $\Omega$ ? | Go to step 3.                | Repair the harness.  |
| <b>3</b><br><b>CHECK CLUTCH SWITCH.</b><br>Remove and check the clutch switch. <Ref. to CC-9, Clutch Switch.>  | Is the clutch switch OK?                  | Clutch switch circuit is OK. | Replace the clutch switch.   |



# DIAGNOSTIC PROCEDURE WITH SYMPTOM

## CRUISE CONTROL SYSTEM (DIAGNOSTICS)

### I: CHECK INHIBITOR SWITCH (AT MODEL)

#### TROUBLE SYMPTOM:

Cruise control cannot be set.

#### WIRING DIAGRAM:

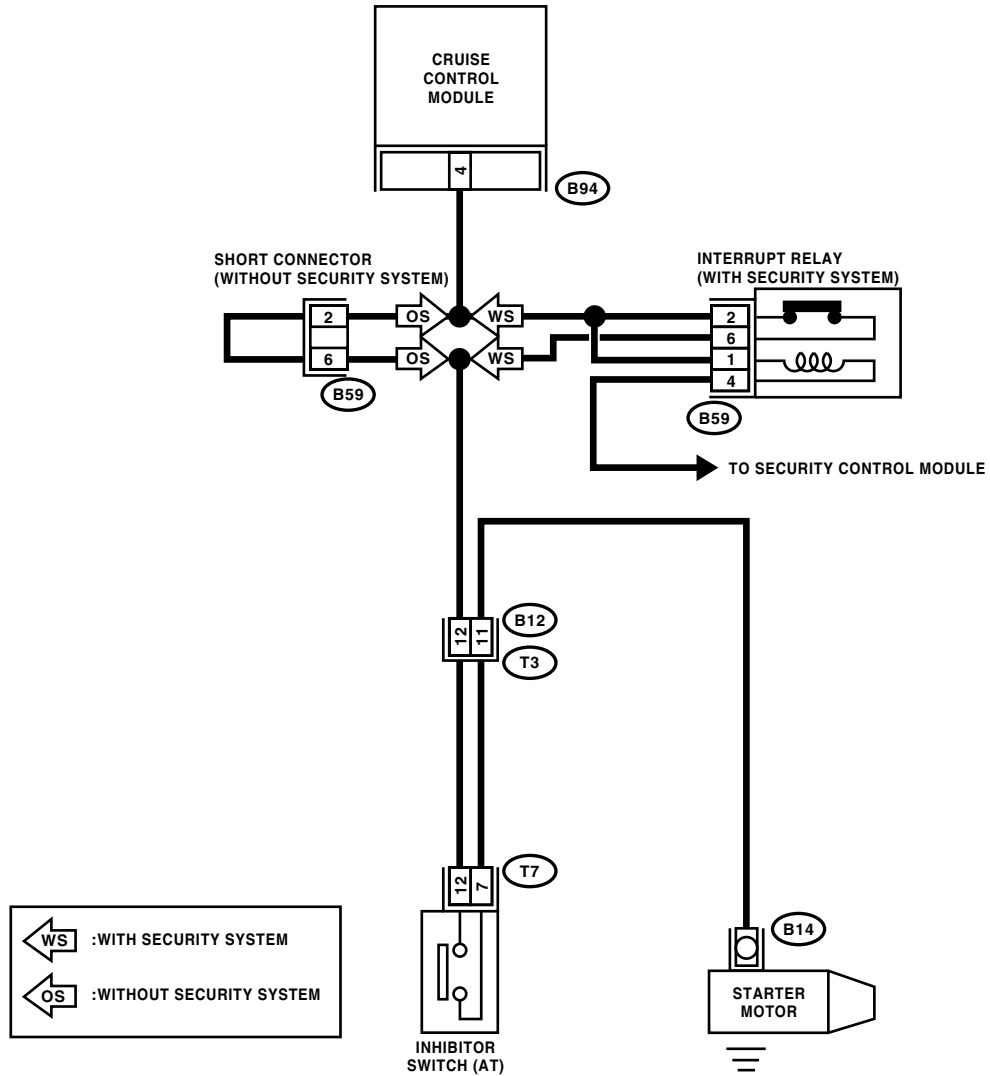

**B59**



**B12**

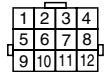

**T7**



**B94**

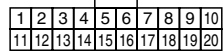

# DIAGNOSTIC PROCEDURE WITH SYMPTOM

## CRUISE CONTROL SYSTEM (DIAGNOSTICS)

| Step     | Check   | Yes                                       | No   |
|----------|---|---|--|
| <b>1</b> | <b>CHECK INHIBITOR SWITCH CIRCUIT.</b><br>1) Turn the ignition switch to OFF.<br>2) Disconnect the inhibitor switch harness connector.<br>3) Turn the ignition switch to ON.<br>4) Turn the cruise control main switch to ON.<br>5) Measure the voltage between harness connector terminal and chassis ground.<br><b>Connector &amp; terminal</b><br><b>(T7) No. 12 (+) — Chassis ground (-):</b> | Is the voltage more than 10 V?            | Go to step 2.<br><br>Check the harness for open or short between inhibitor switch and cruise control module. |
| <b>2</b> | <b>CHECK INHIBITOR SWITCH CIRCUIT.</b><br>1) Turn the cruise control main switch and ignition switch to OFF.<br>2) Disconnect the starter motor harness connector.<br>3) Measure the resistance between inhibitor switch harness connector terminal and chassis ground.<br><b>Connector &amp; terminal</b><br><b>(T7) No. 7 — (B14) No. 1:</b>  | Is the resistance less than 10 $\Omega$ ? | Go to step 3.<br><br>Repair the harness.   |
| <b>3</b> | <b>CHECK INHIBITOR SWITCH.</b><br>Remove and check the inhibitor switch. <Ref. to CC-10, Inhibitor Switch.>   | Is the inhibitor switch OK?               | Inhibitor switch circuit is OK.<br><br>Replace the inhibitor switch.   |