

CROSSBAR

OPTION PARTS

3. Crossbar

A: REMOVAL

- 1) Remove the TORX® bolt T30 from each end support.
- 2) Rotate the lower clamp of each end support about 90° downward to remove the crossbar.

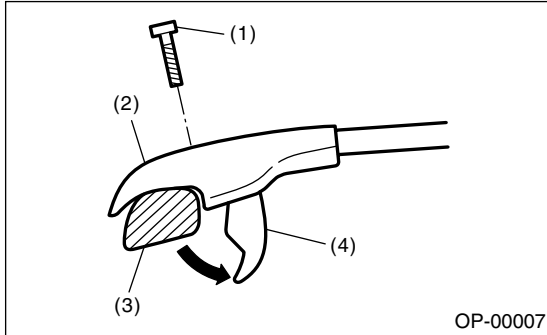

- (1) TORX® bolt T30
- (2) End support
- (3) Roof rail
- (4) Lower clamp

CAUTION:

Pay attention to avoid damage to the roof panel during removal or installation.

B: INSTALLATION

- 1) Rotate the lower clamp of each end support about 90° downward.
- 2) Set the front crossbar so that front direction mark on the right side top face of crossbar point in the direction of vehicle front.
- 3) Place the crossbar end support at position 76.2 mm (3 in) behind the joint of front roof rail support and roof rail.

Length A:

76.2 mm (3 in)

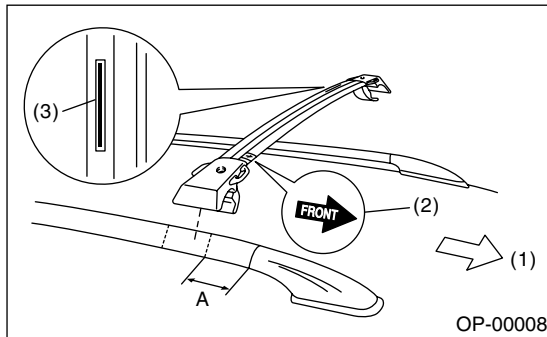

- (1) Front of vehicle
- (2) Front direction mark
- (3) Caution label (Front crossbar)

- 4) Set the rear crossbar so that front direction mark on the right side top face of crossbar point in the direction of vehicle front.
- 5) Place the crossbar end support on a joint of rear roof rail support and roof rail.

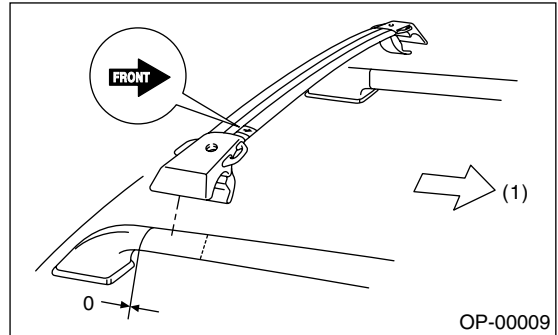

- (1) Front of vehicle
- (2) Front direction mark

- 6) Tighten the end support and clamp using TORX® bolt T30.