

BACK-UP LIGHT SYSTEM

WIRING SYSTEM

23.Back-up Light System

A: SCHEMATIC

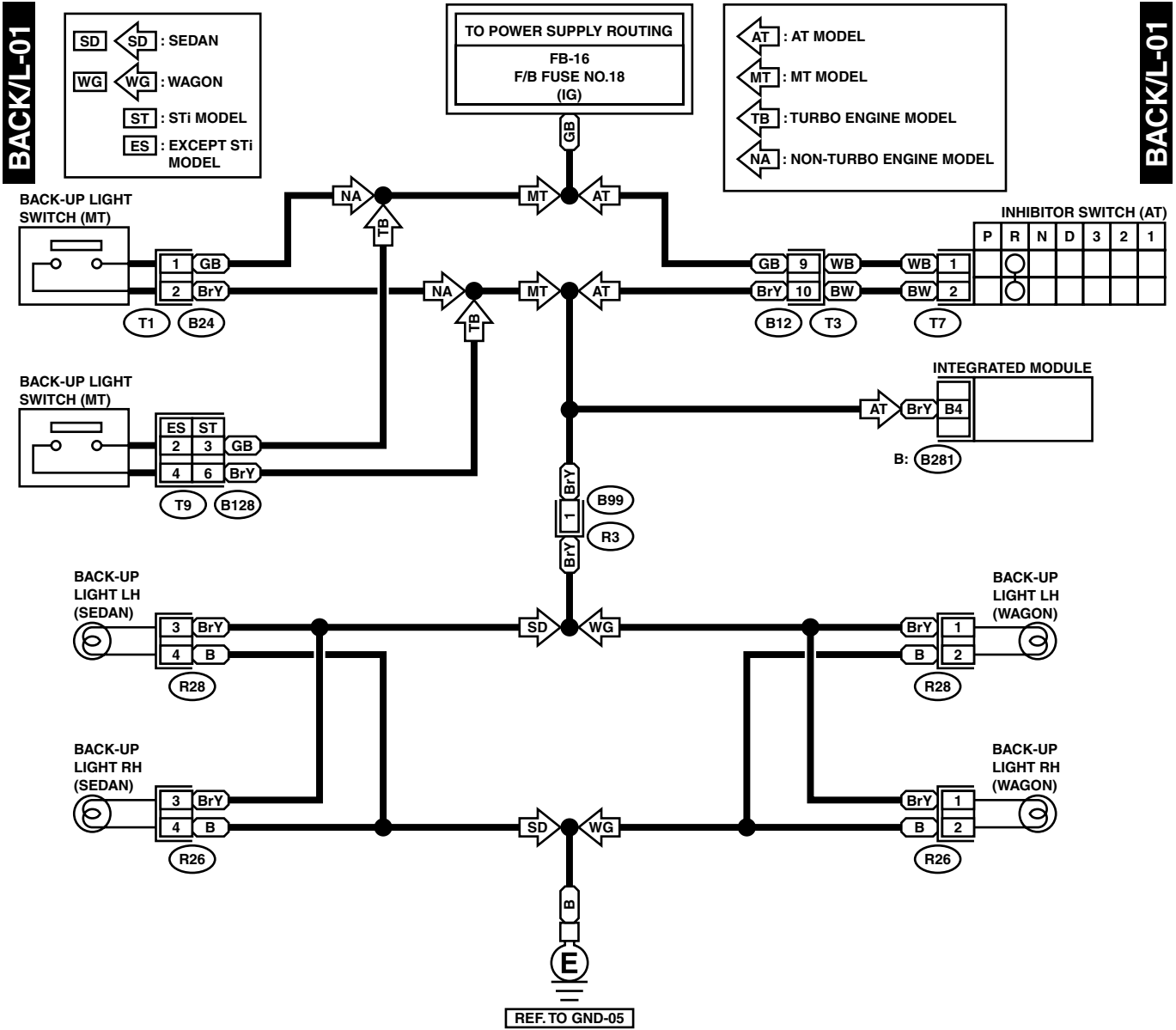

BACK/L-01

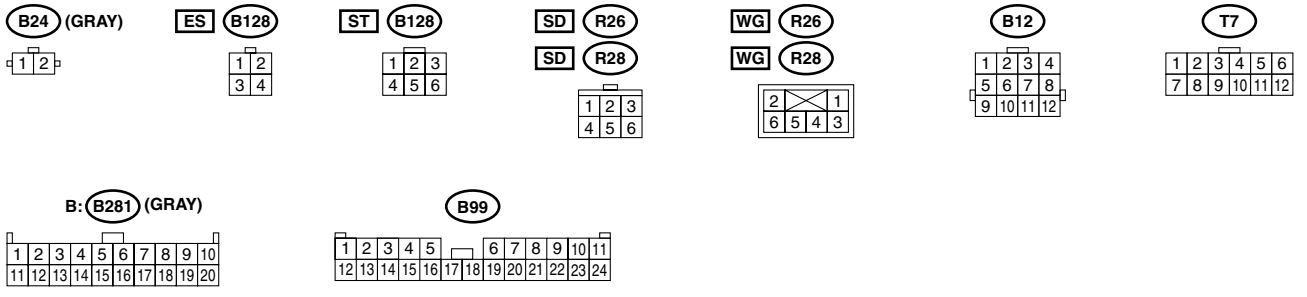

WI-02541