

STARTER SYSTEM

WIRING SYSTEM

42. Starter System

A: SCHEMATIC

1. MT MODEL

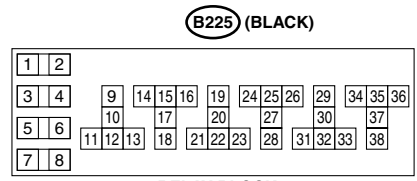
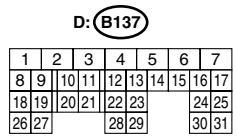
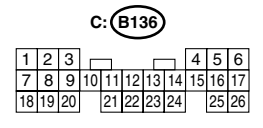
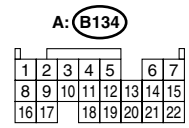
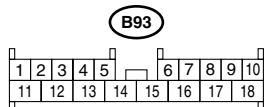
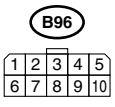
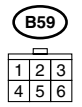
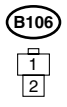
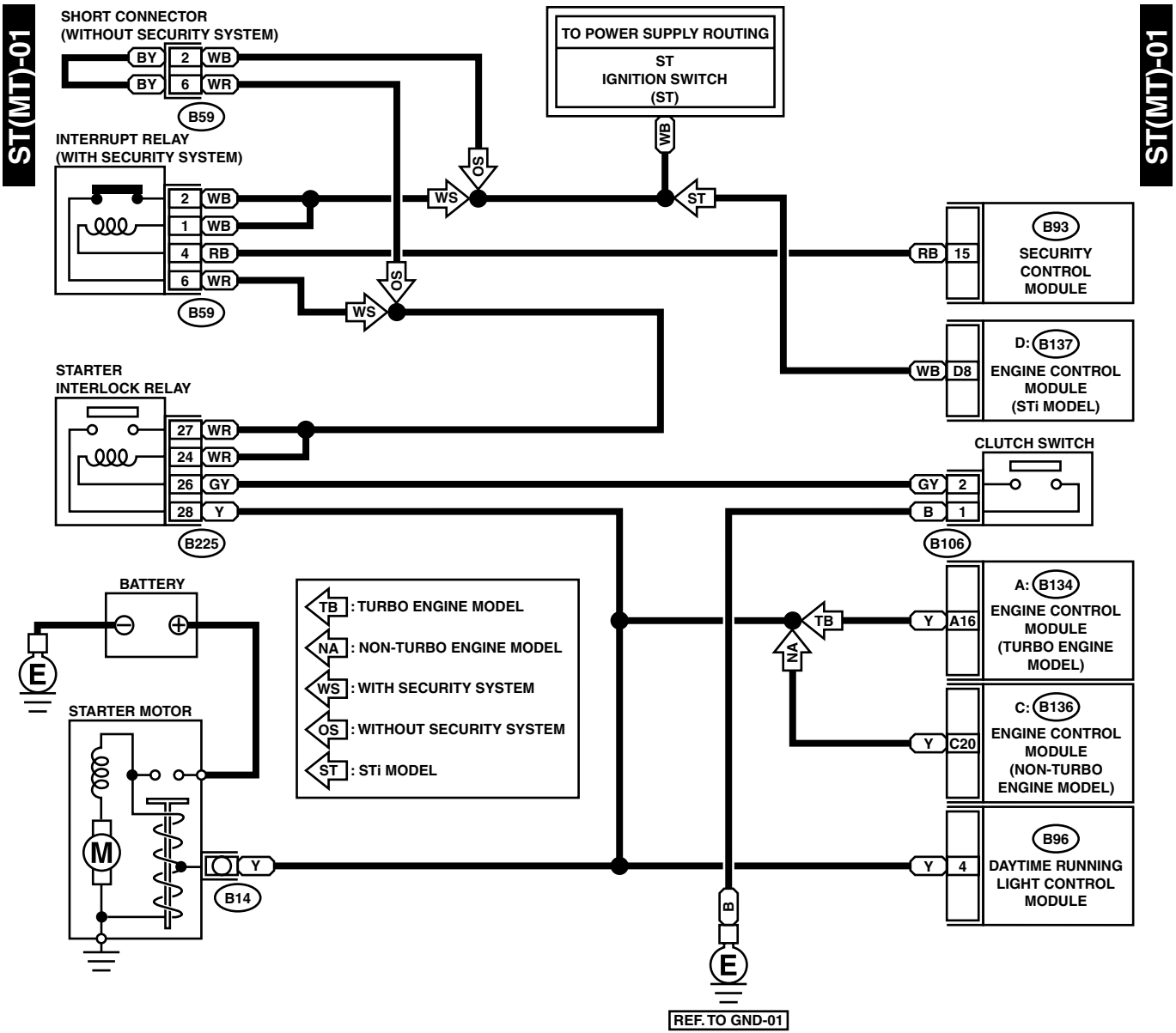

RELAY BLOCK

STARTER SYSTEM

WIRING SYSTEM

2. AT MODEL

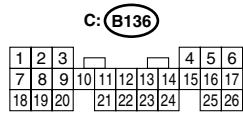
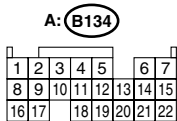
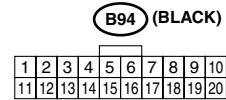
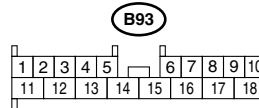
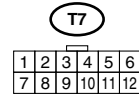
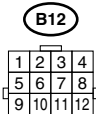
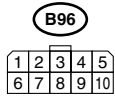
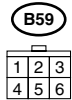
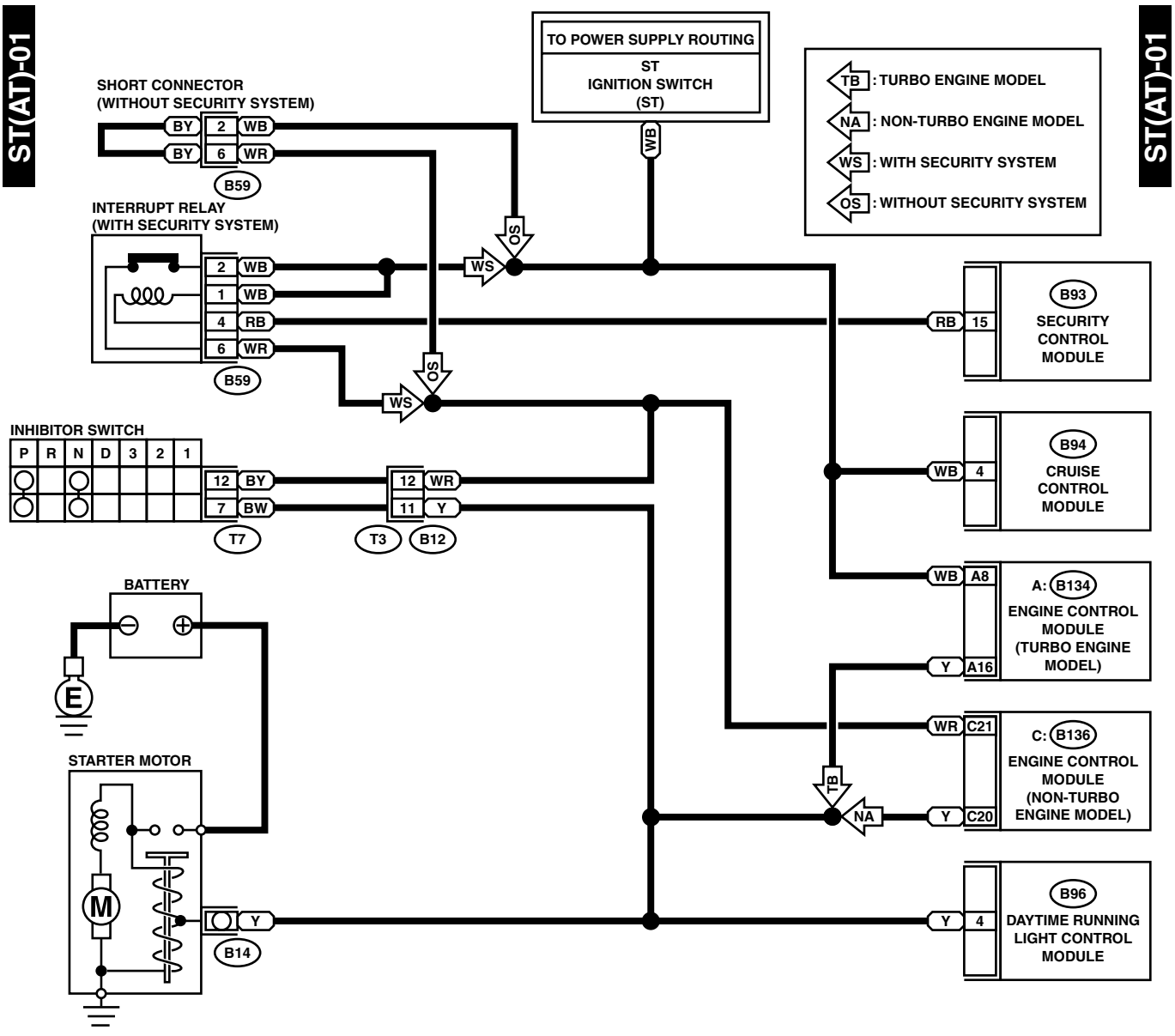

WI-01172