

## GENERAL

### MECHANICAL

#### 1. General

The engine used in this vehicle is of a horizontally opposed, four-cylinder design. This four-stroke-cycle, water-cooled, SOHC engine uses a total of 16 valves and its main components are made of aluminum alloy. It is fueled by a multiple fuel injection system.

The engine's major structural and functional features are as follows:

- The cylinder head forms pentroof combustion chambers, each having a spark plug located at its center and two each of intake and exhaust valves (four valves per cylinder). The intake and exhaust ports are located in a cross-flow arrangement.
- There are a screw and nut at the valve end of each rocker arm. They are used for adjusting the valve clearance.
- A single timing belt drives two camshafts on the left and right banks and the engine coolant pump on the left bank. Belt tension is automatically adjusted by a belt tension adjuster, eliminating need for a manual adjustment.
- The crankshaft is supported by five bearings with high rigidity and strength.
- The cylinder block is an aluminum die casting fitted with iron die-cast cylinder liners.

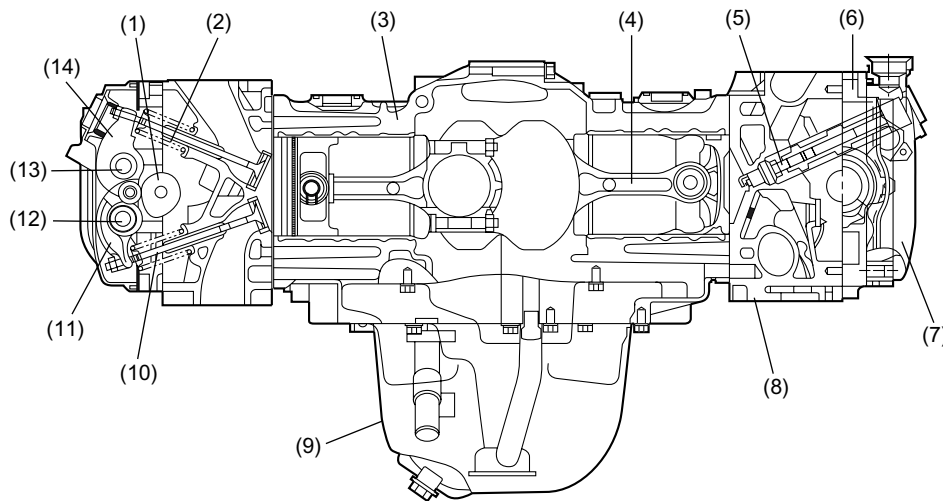

ME-00312

- |                    |                        |                           |
|--------------------|------------------------|---------------------------|
| (1) Camshaft       | (6) Camshaft cap       | (11) Exhaust rocker arm   |
| (2) Intake valve   | (7) Valve rocker cover | (12) Exhaust rocker shaft |
| (3) Cylinder Block | (8) Cylinder Head      | (13) Intake rocker shaft  |
| (4) Connecting rod | (9) Oil pan            | (14) Intake rocker arm    |
| (5) Spark plug     | (10) Exhaust valve     |                           |

#### ME(H4SO)-2