

CAMSHAFT

MECHANICAL

5. Camshaft

The DOHC engine uses four camshafts in all; intake and exhaust camshafts on each of the right and left banks.

The cam lobe noses are finished by “chill” treatment to increase wear resistance and anti-scuffing properties.

Each camshaft is supported at its three journals and held in position by three camshaft caps. Each camshaft has a flange which fits in the corresponding groove in the cylinder head to receive thrust forces generated in the camshaft.

ME(H4DOTC)-7

CAMSHAFT

MECHANICAL

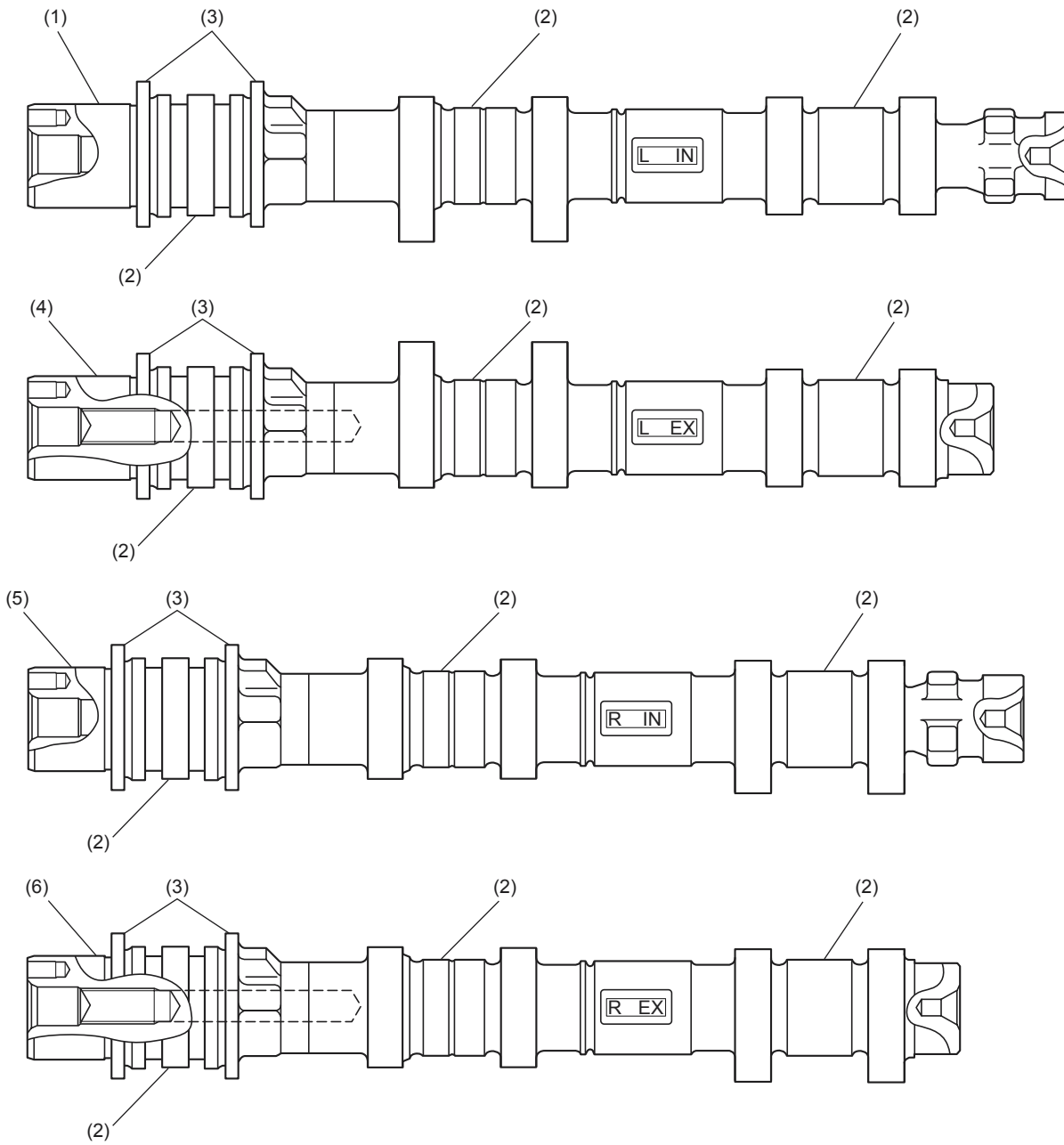

ME-00743

- (1) Intake camshaft LH
- (2) Journal
- (3) Flange

- (4) Exhaust camshaft LH
- (5) Intake camshaft RH
- (6) Exhaust camshaft RH

ME(H4DOTC)-8