

OIL PAN AND OIL STRAINER

LUBRICATION

5. Oil Pan and Oil Strainer

- The oil pan is attached to the cylinder block using liquid gasket for sealing. The oil strainer is a metal net type and removes large foreign particles from the engine oil. It is located in the middle of the oil pan. The pipe from the strainer is connected to the inlet port of the oil pump in the left bank of the cylinder block.
- There is a baffle plate in the oil pan, near the bottom of the cylinder block. It stabilizes the oil level and reinforces the oil pan.

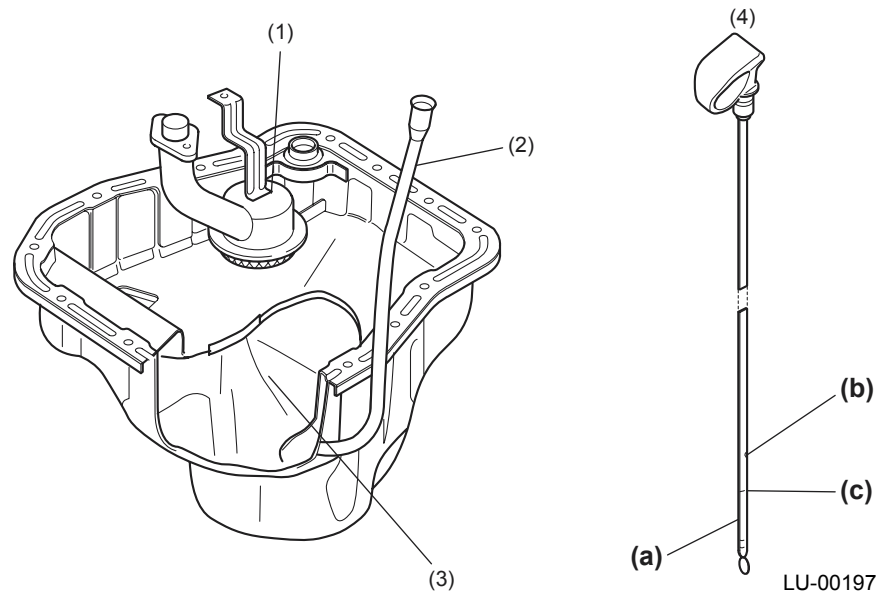

- (1) Oil strainer
- (2) Level gauge guide
- (3) Baffle plate
- (4) Oil level gauge

- (a) LOW level
- (b) FULL level (engine HOT condition)
- (c) FULL level (engine COLD condition)

LU(STi)-7