

GENERAL

SPEED CONTROL SYSTEM

1. General

An electronically controlled throttle is adopted.

The movement of the accelerator pedal is converted into electrical signals by the accelerator pedal position sensor and these signals are sent to the ECM.

The ECM controls the operation of the throttle body based on the signals from the accelerator pedal position sensor and on other driving conditions.

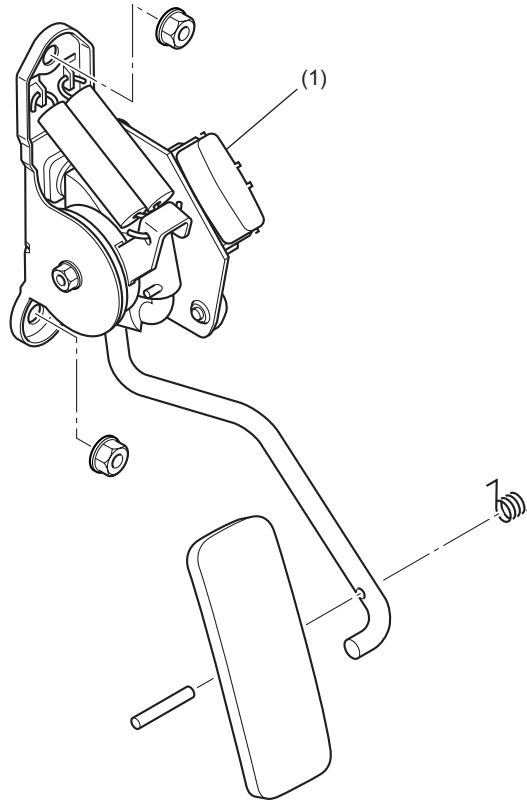

SP-00050

(1) Accelerator pedal position sensor

SP(STi)-2