

### 3. Ignition Switch

#### A: REMOVAL AND INSTALLATION

1) Remove screws, separate upper column cover and lower column cover.

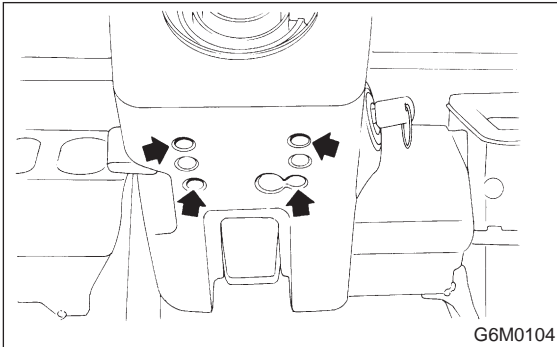

- 2) Remove knee protector.
- 3) Remove meter visor.
- 4) Disconnect ignition switch connector from body harness.
- 5) Using a drift and hammer, hit the torn bolt head to loosen and remove the ignition switch.

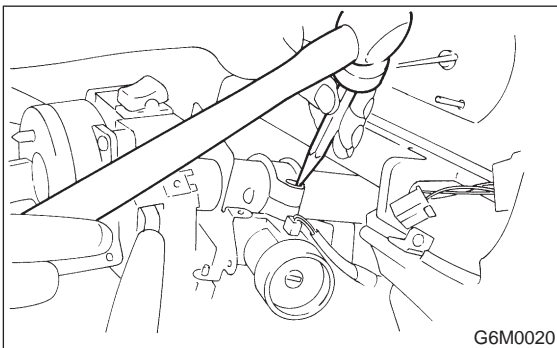

6) Installation is in the reverse order of removal.

**NOTE:**

When installing, tighten the connecting bolt until its head twists off.

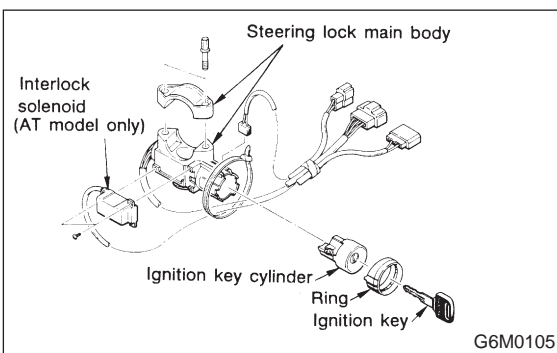

### 4. Lighting

#### A: ADJUSTMENT

##### 1. HEADLIGHT AIMING

**CAUTION:**

Turn off the light before adjusting headlight aiming. If the light is necessary to check aiming, do not turn on for more than two minutes.

**NOTE:**

Before checking the headlight aiming, be sure of the following:

- The area around the headlight has not sustained any accident, damage or other type of deformation.
- Vehicle is parked on level ground.
- The inflation pressure of tires is correct.
- Vehicle's gas tank is fully charged.
- Bounce the vehicle several times to normalize the suspension.
- Make certain that someone is seated in the driver's seat.

1) Place a cloth over the headlight that does not require aiming adjustment.

2) Turn the headlights on. Perform the aiming adjustment for the other headlight as follows:

**CAUTION:**

Do not perform lateral headlight aiming adjustment.

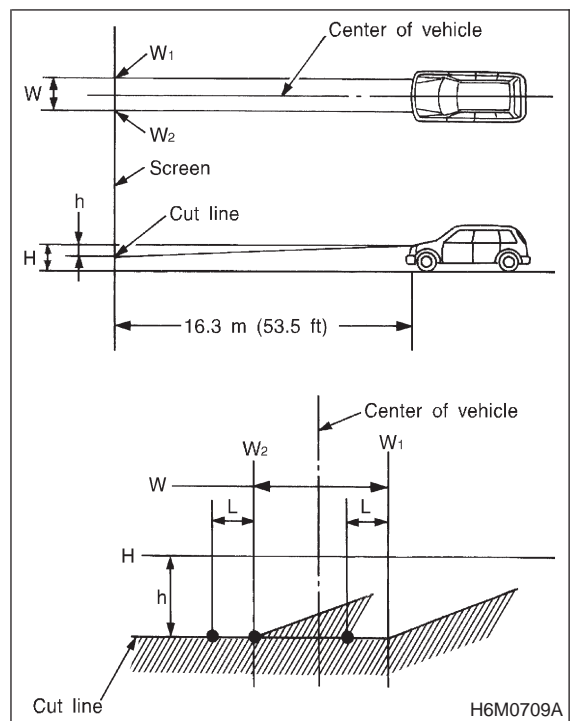

	W	H	L	h
Except OUTBACK	1,070 (42.13)	630 (24.80)	569 (22.40)	114 (4.49)
OUTBACK	1,070 (42.13)	650 (25.59)	569 (22.40)	114 (4.49)

Unit: mm (in)

## B: REMOVAL AND INSTALLATION

### 1. HEADLIGHT BULB

- 1) Disconnect the connector from inside of the engine compartment.
- 2) Remove rubber cap.
- 3) Remove the light bulb retaining spring to remove the bulb.

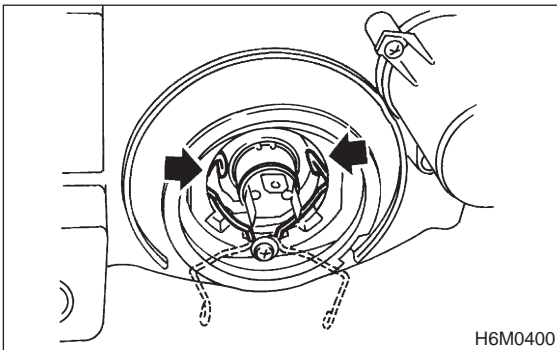

- 4) Replace the bulb with a new one and hook the spring.
- 5) Attach the rubber cap and connect the connector.

#### CAUTION:

● Since the tungsten halogen bulb operates at high temperature, dirt and oil on the bulb surface decreases the bulb's useful life. When replacing the bulb, hold the flange portion and do not touch the glass portion.

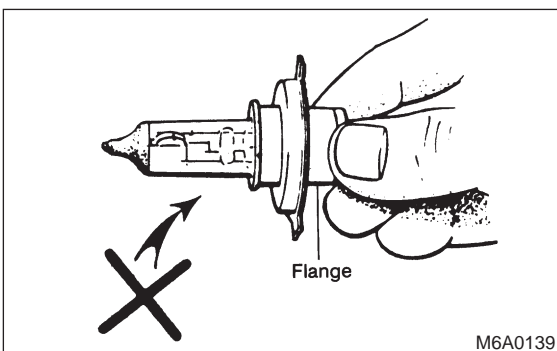

- Attach the rubber cap with letters TOP on the top so that the drain hole will be on the lower side.

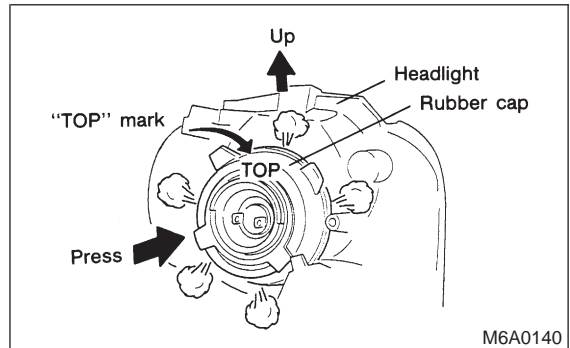

- To keep water out, correctly engage the groove portion of the rubber cap.

### 2. HEADLIGHT AND SIDE MARKER LIGHT

- 1) Remove front grille and disconnect connector from headlight.
- 2) Remove screw then remove side marker light while disconnecting connector.

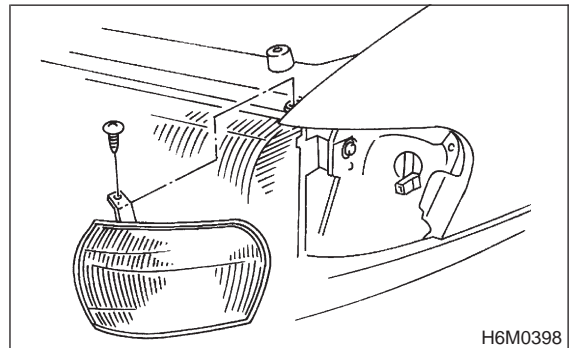

- 3) Remove screws and bolts which secure headlight and remove headlight.

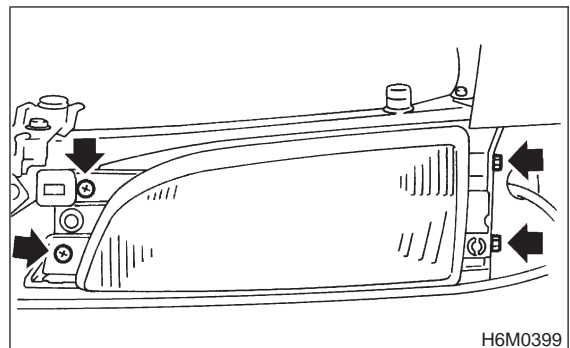

- 4) Installation is in the reverse order of removal.

#### Tightening torque:

**6.4±0.5 N·m (0.65±0.05 kg-m, 4.7±0.4 ft-lb)**

#### NOTE:

When installing, securely fit clip (on fender side) into locating (on side marker light side).

## 3. REAR COMBINATION LIGHT

- 1) Remove rear trim.
- 2) Remove nuts and disconnect connector.

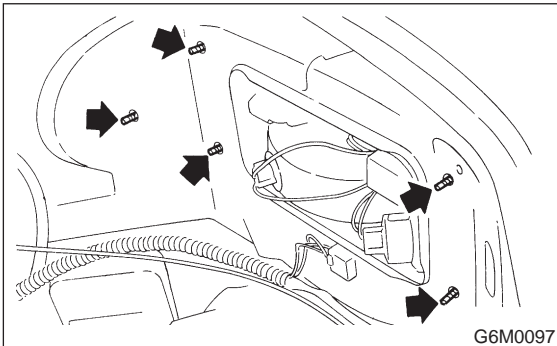

- 3) Attach adhesive cloth tape to body area around rear combination light.
- 4) Using a standard screwdriver, carefully pry rear combination light off and away from the front of vehicle.
- 5) Installation is in the reverse order of removal.

### **Tightening torque:**

**$6.4 \pm 0.5 \text{ N}\cdot\text{m}$  ( $0.65 \pm 0.05 \text{ kg}\cdot\text{m}$ ,  $4.7 \pm 0.4 \text{ ft}\cdot\text{lb}$ )**

### **CAUTION:**

- Do not pry rear combination light forcefully as this may scratch vehicle body.
- Remove all traces of adhesive tape from body before installation.
- Attach butyl rubber tape to back of rear combination light before installing rear combination light on body for sealing purposes.

## 4. COMBINATION SWITCH

- 1) Remove instrument panel lower cover. <Ref. to 5-4 [W1A0].>
- 2) Remove screws which secure upper column cover to lower column cover.

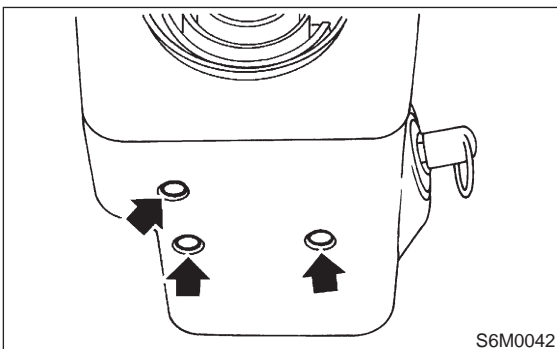

- 3) Disconnect connector from combination switch.

- 4) Remove screws which secure switch and remove switch.

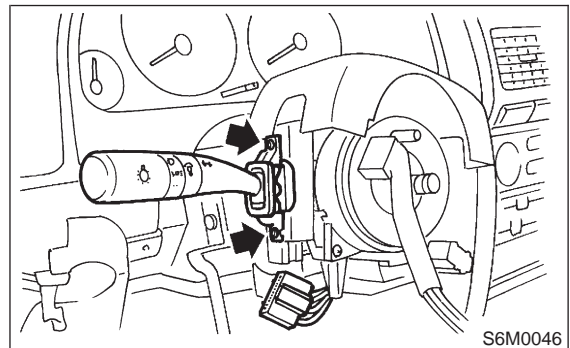

- 5) Installation is in the reverse order of removal.

**C: INSPECTION**

**1. COMBINATION SWITCH (LIGHTING)**

Move combination switch to respective positions and check continuity between terminals.

• LIGHTING SWITCH

Terminal Switch position	16	14	13
OFF			
Tail	○	○	
Head	○	○	○

• PARKING SWITCH

Terminal Switch position	19	21	18
OFF	○	○	
ON		○	○

• DIMMER AND PASSING SWITCH

Terminal Switch position	16	17	7	8
Flash	○		○	○
Low beam	○	○		
HI-beam	○		○	

H6M0500B

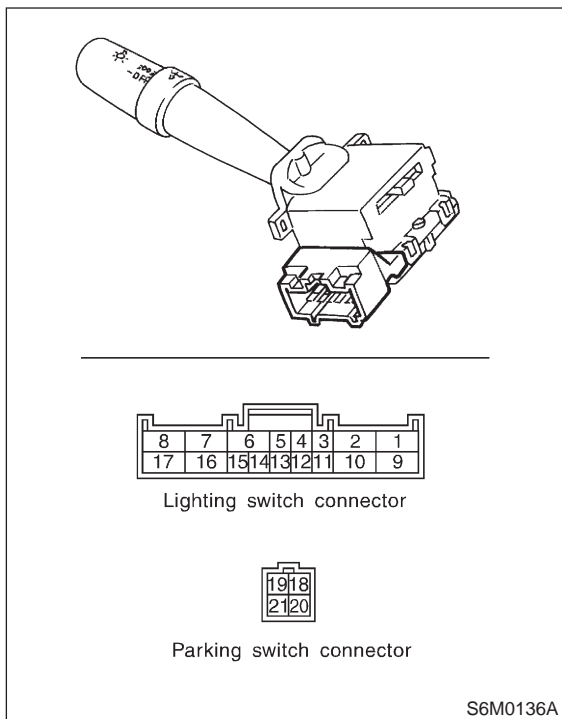

**2. HEADLIGHT RELAY**

Check continuity between terminals when terminal No. 4 is connected to battery and terminal No. 3 is grounded.

When current flows.	Between terminals No. 1 and No. 2	Continuity exists.
When current does not flow.	Between terminals No. 1 and No. 2	Continuity does not exist.
	Between terminals No. 3 and No. 4	Continuity exists.

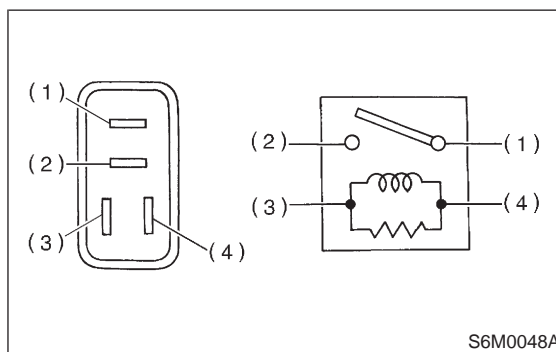

**3. TAIL AND ILLUMINATION RELAY**

Check continuity between terminals (indicated in table) when terminal No. 4 is connected to battery and terminal No. 3 is grounded.

When current flows.	Between terminals No. 1 and No. 2	Continuity exists.
When current does not flow.	Between terminals No. 1 and No. 2	Continuity does not exist.
	Between terminals No. 3 and No. 4	Continuity exists.

