

5. Crankshaft and Piston

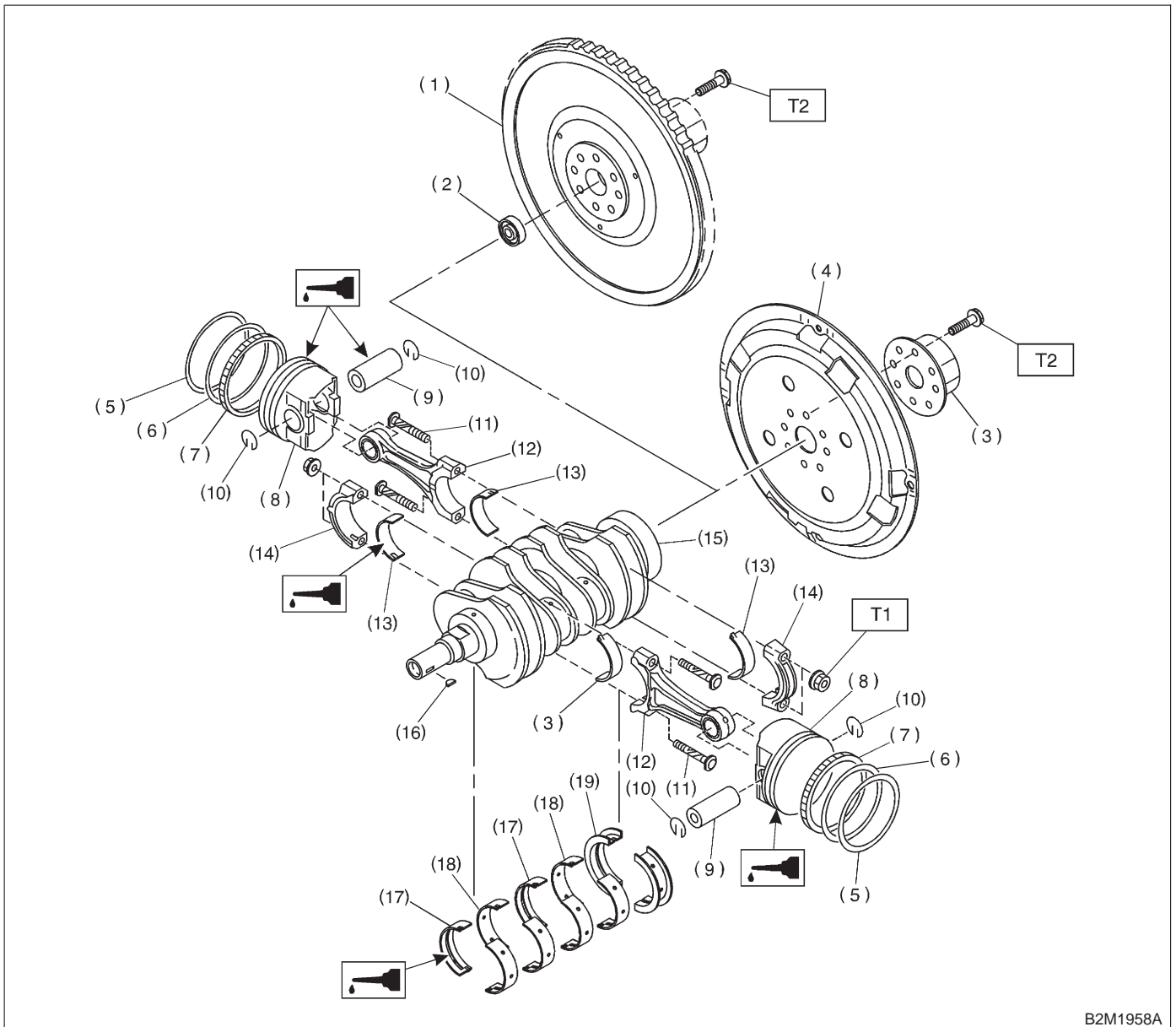

B2M1958A

- | | | |
|------------------------|-----------------------------|--------------------------------|
| (1) Flywheel (MT) | (9) Piston pin | (17) Crankshaft bearing #1, #3 |
| (2) Ball bearing (MT) | (10) Circlip | (18) Crankshaft bearing #2, #4 |
| (3) Reinforcement (AT) | (11) Connecting rod bolt | (19) Crankshaft bearing #5 |
| (4) Drive plate (AT) | (12) Connecting rod | |
| (5) Top ring | (13) Connecting rod bearing | |
| (6) Second ring | (14) Connecting rod cap | |
| (7) Oil ring | (15) Crankshaft | |
| (8) Piston | (16) Woodruff key | |

Tightening torque: N-m (kg-m, ft-lb)

T1: 44±2 (4.5±0.2, 32.5±1.4)

T2: 72±3 (7.3±0.3, 52.8±2.2)