

## 4. Crankshaft Position, Camshaft Position and Knock Sensors

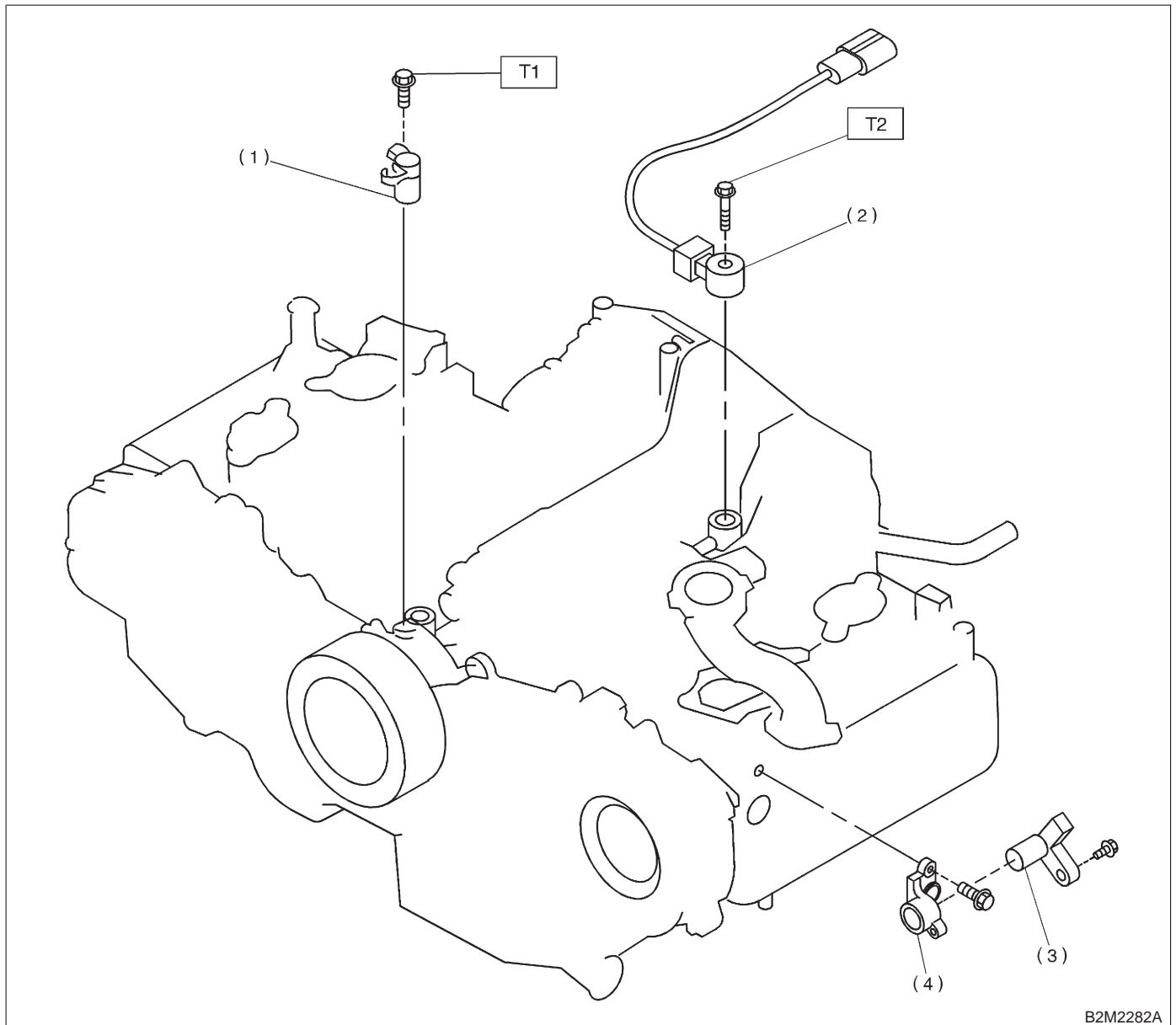

- (1) Crankangle position sensor
- (2) Knock sensor
- (3) Camshaft position sensor
- (4) Camshaft position sensor support

**Tightening torque: N·m (kg·m, ft·lb)**

**T1: 6.4±0.5 (0.65±0.05, 4.7±0.4)**

**T2: 23.5±2.9 (2.4±0.3, 17.4±2.2)**