

2. Intake Unit with Evaporator

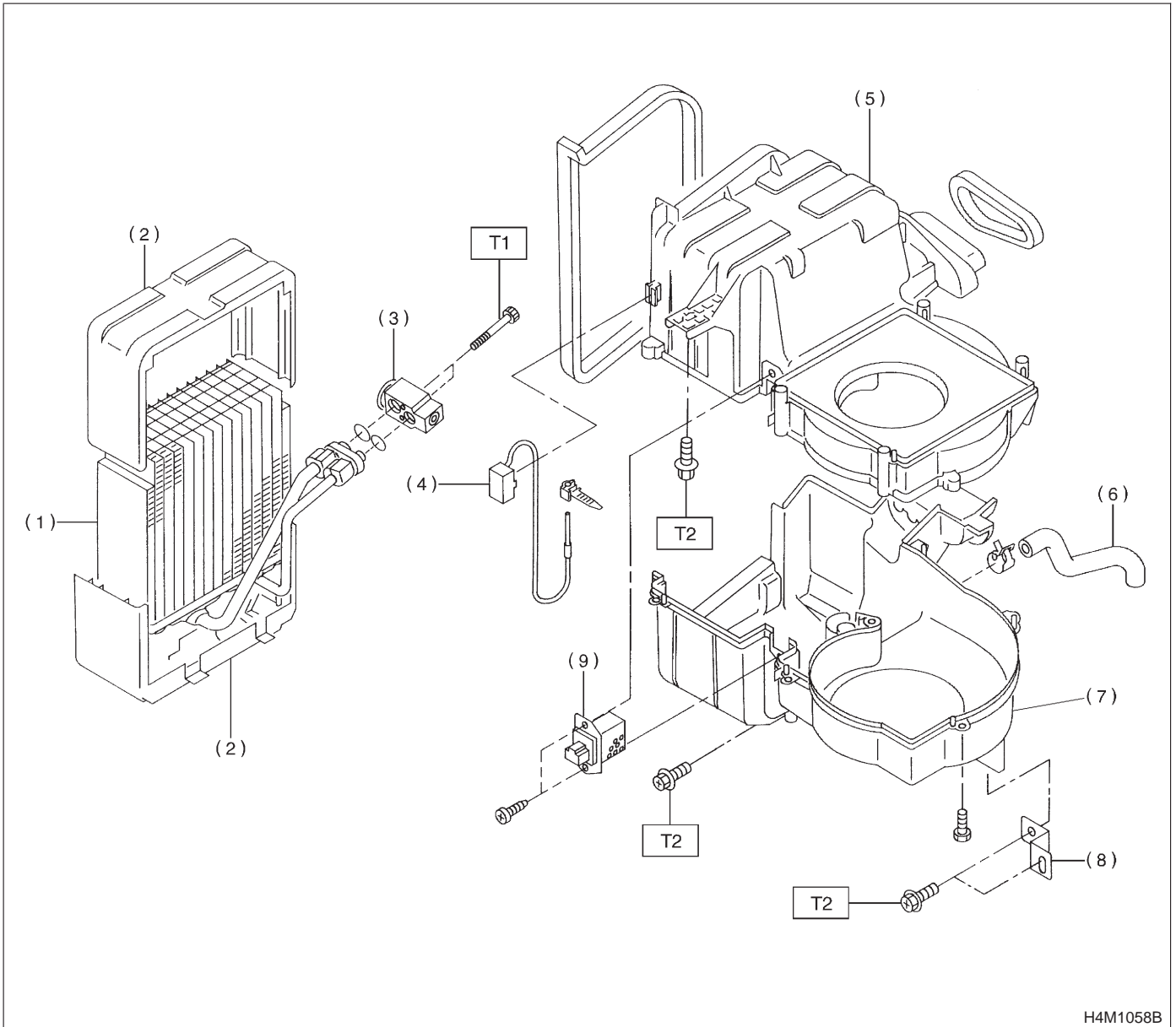

- | | |
|------------------------------|----------------------------|
| (1) Evaporator | (6) Drain hose |
| (2) Insulator | (7) Intake unit case lower |
| (3) Block expansion valve | (8) Mount bracket |
| (4) Thermo control amplifier | (9) Resistor |
| (5) Intake unit case upper | |

Tightening torque: N-m (kg-m, ft-lb)

T1: 4±1 (0.4±0.1, 2.9±0.7)

T2: 7.4±2.0 (0.75±0.2, 5.4±1.4)