

4. O-ring Connections

A: GENERAL

The following points should be kept in mind when assembling O-ring connections:

- 1) Avoid unnecessary handling and contact of O-rings with your hands, since even clean fingers contain body acids, which can contaminate the O-ring surface.
- 2) Do not handle O-rings with gloves, shop towels, etc., since lint particles may cling to the O-ring, possibly causing a leak upon assembly.
- 3) Always lubricate O-rings before assembly to allow the O-ring to seat itself properly.
- 4) Be certain to use torque wrenches when tightening O-ring fittings, because overtightening can not only damage the O-ring, but it can distort the tube end as well.

B: REMOVE PROTECTIVE SEALS

- 1) Just prior to making the connection, remove the protective seals.

CAUTION:

If for any reason you have to stop before making a connection, recap the tube, component or fitting.

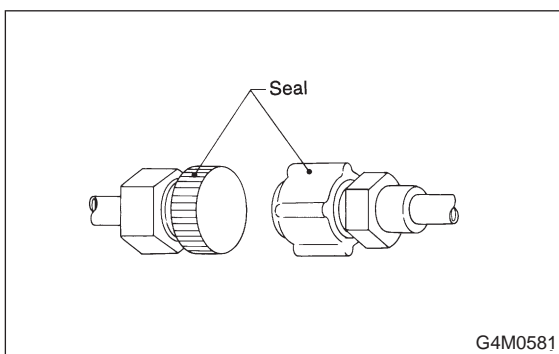

- 2) Visually inspect the O-ring surface, the O-ring mating surface, the threads and the connection points. If a defective part is found, replace it. The O-ring must sit square against the tube bead. If necessary, slide the O-ring into proper position with clean hands.

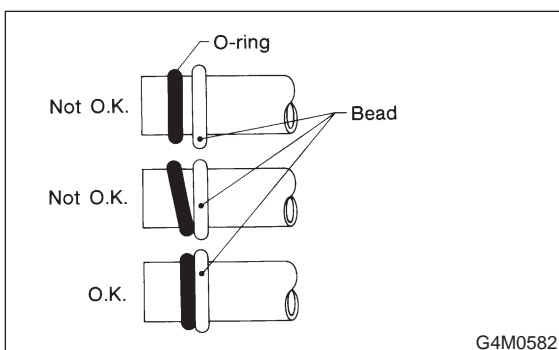

C: LUBRICATE THE COMPONENTS

For lubrication of the components, use only refrigerant oil as described in the appropriate service manual. Apply oil from an oil squirt gun or other closed container. Do not use your finger to spread the oil over the O-ring.

Apply a small amount of refrigerant oil to the top and sides of the O-ring. The area covered by oil should include the O-ring and the tube bead.

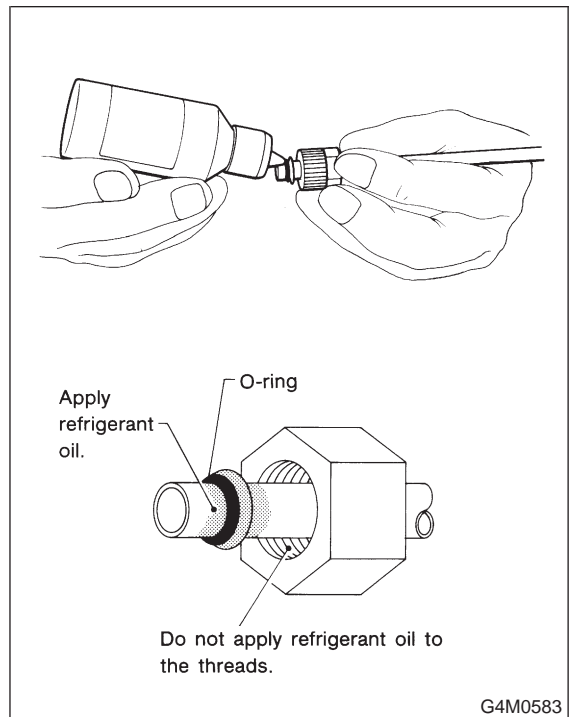

D: TORQUE THE FITTING

Using a back-up wrench in conjunction with a calibrated torque wrench, torque the connection to the midrange of the specification.

After completion of torquing, use a clean shop towel to remove any excess oil from the connection or any oil that may have dripped on the vehicle body or other parts.

CAUTION:

If a leak is suspected after torquing, do not retighten or retorquing the connection. Instead, disassemble the connection, remove the O-ring, and inspect the O-ring, threads, joints and seating surfaces.

