

### 3. Tools and Equipment

The following section provides information about the tools and equipment that will be necessary to properly service the A/C system.

Since equipment may vary slightly depending on the manufacturer, it is important to always read and follow the manufacturer's instructions.

**CAUTION:**

**When working on vehicles with the HFC-134a system, only use HFC-134a specified tools and parts. Do not mix with CFC-12 tools and parts. If HFC-134a and CFC-12 refrigerant or com-**

**pressor oil is mixed, poor lubrication will result and the compressor itself may be destroyed. In order to help prevent mixing HFC-134a and CFC-12 parts and liquid, the tool and screw type and the type of service valves used are different. The gas leak detectors for the HFC-134a and CFC-12 systems must also not be interchanged.**

	HFC-134a	CFC-12
Tool & screw type	Millimeter size	Inch size
Valve type	Quick joint type	Screw-in type

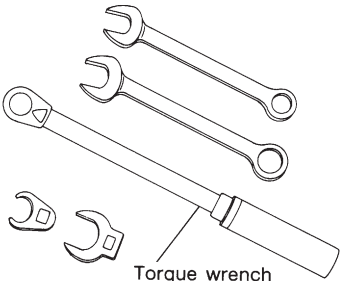
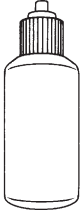
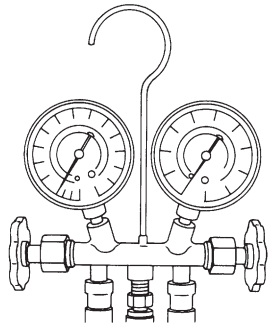
Tools and Equipment	Description
<ul style="list-style-type: none"> <li>● WRENCH</li> </ul> <p>Various <b>WRENCHES</b> will be required to service any A/C system. A 7 to 40 N·m (0.7 to 4.1 kg·m, 5 to 30 ft·lb) torque wrench with various crowfoot wrenches will be needed. Open end or flare nut wrenches will be needed for back-up on the tube and hose fittings.</p>	 <p>Torque wrench</p> <p style="text-align: right;">G4M0571</p>
<ul style="list-style-type: none"> <li>● APPLICATOR BOTTLE</li> </ul> <p>A small <b>APPLICATOR BOTTLE</b> is recommended to apply refrigerant oil to the various parts. They can be obtained at a hardware or drug store.</p>	 <p style="text-align: right;">G4M0572</p>
<ul style="list-style-type: none"> <li>● MANIFOLD GAUGE SET</li> </ul> <p>A <b>MANIFOLD GAUGE SET</b> (with hoses) can be obtained from either a commercial refrigeration supply house or from an auto shop equipment supplier.</p>	 <p style="text-align: right;">G4M0573</p>

# SERVICE PROCEDURE

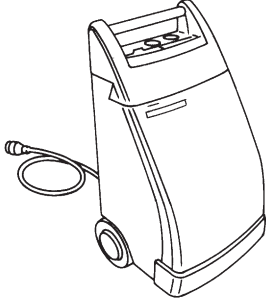
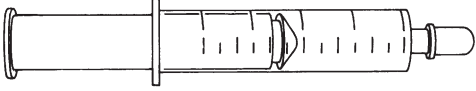
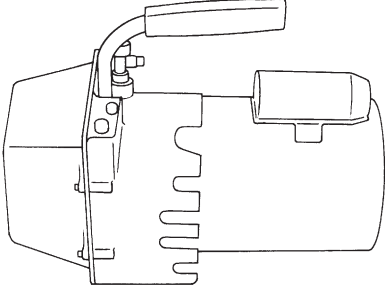
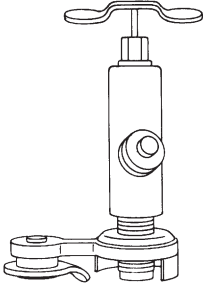
Tools and Equipment	Description
<p>● <b>REFRIGERANT RECOVERY SYSTEM</b></p> <p>A <b>REFRIGERANT RECOVERY SYSTEM</b> is used for the recovery and reuse of A/C system refrigerant after contaminants and moisture have been removed from the refrigerant.</p>	 <p style="text-align: right;">G4M0574</p>
<p>● <b>SYRINGE</b></p> <p>A graduated plastic <b>SYRINGE</b> will be needed to add oil back into the system. The syringe can be found at a pharmacy or drug store.</p>	 <p style="text-align: right;">G4M0575</p>
<p>● <b>VACUUM PUMP</b></p> <p>A <b>VACUUM PUMP</b> (in good working condition) is necessary, and may be obtained from either a commercial refrigeration supply house or an automotive equipment supplier.</p>	 <p style="text-align: right;">G4M0576</p>
<p>● <b>CAN TAP</b></p> <p>A <b>CAN TAP</b> for the 397 g (14 oz) can is available from an auto supply store.</p>	 <p style="text-align: right;">G4M0577</p>

**4-7 [W300]**

**3. Tools and Equipment**

**SERVICE PROCEDURE**

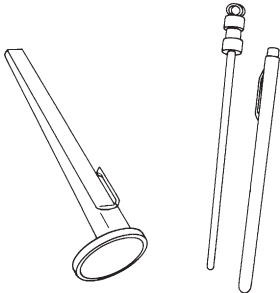
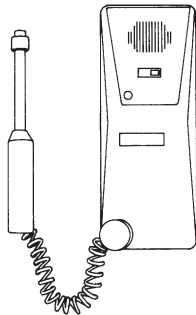
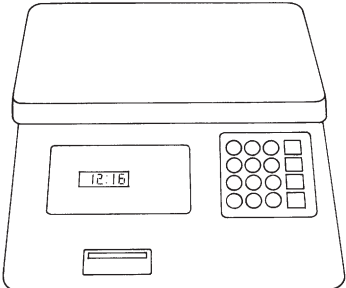
Tools and Equipment	Description
<p>● <b>THERMOMETER</b></p> <p>Pocket <b>THERMOMETERS</b> are available from either industrial hardware store or commercial refrigeration supply houses.</p>	 <p style="text-align: right;">G4M0578</p>
<p>● <b>ELECTRONIC LEAK DETECTOR</b></p> <p>An <b>ELECTRONIC LEAK DETECTOR</b> can be obtained from either a specialty tool supply or an A/C equipment supplier.</p>	 <p style="text-align: right;">G4M0579</p>
<p>● <b>WEIGHT SCALE</b></p> <p>A <b>WEIGHT SCALE</b> such as an electronic charging scale or a bathroom scale with digital display will be needed if a 13.6 kg (30 lb) refrigerant container is used.</p>	 <p style="text-align: right;">G4M0580</p>