

6. ABS System

A: SENSOR

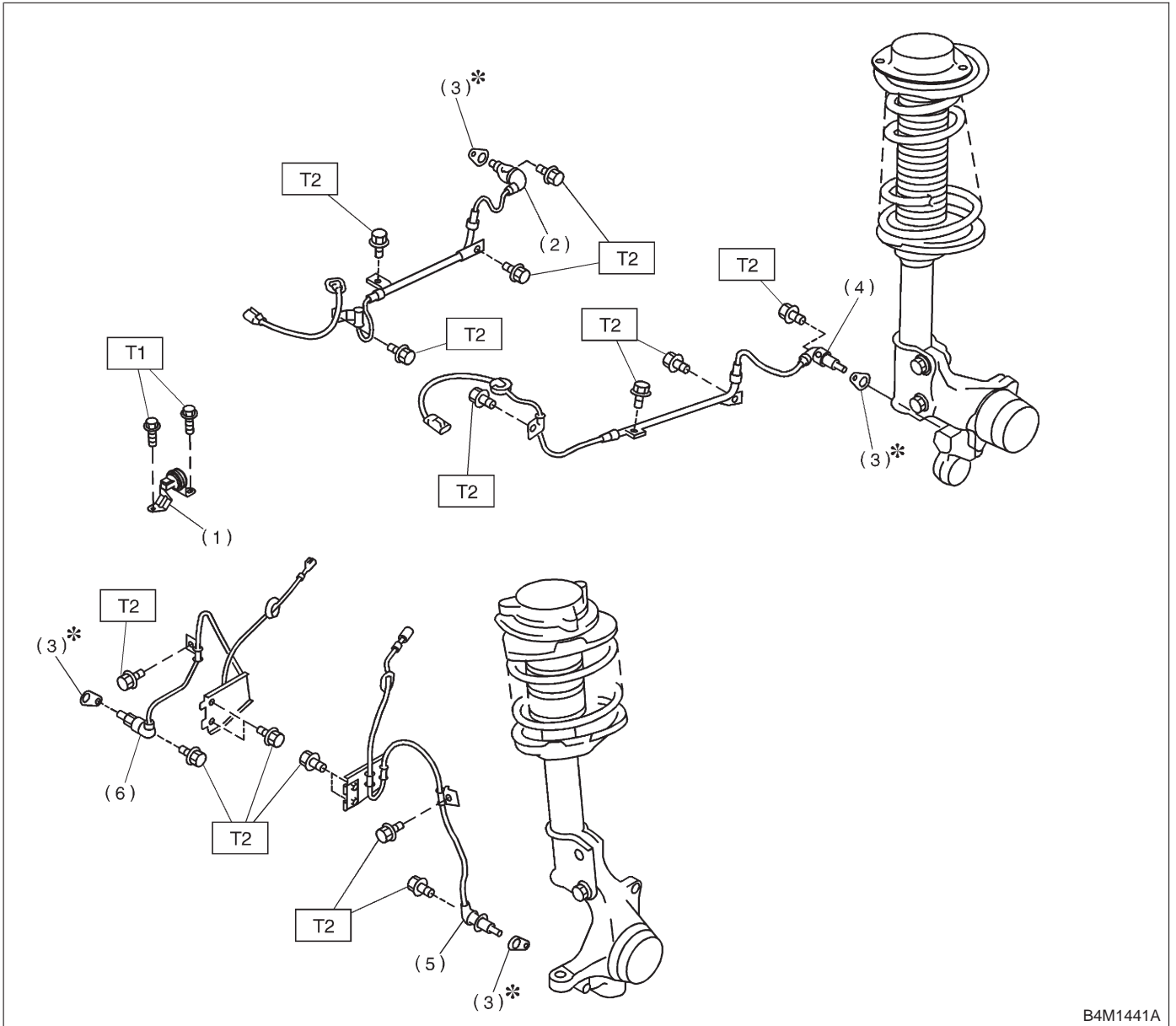

B4M1441A

- (1) G sensor
- (2) Rear ABS sensor RH
- (3) ABS spacer
- (4) Rear ABS sensor LH
- (5) Front ABS sensor LH
- (6) Front ABS sensor RH

**Tightening torque: N·m (kg·m, ft·lb)**

**T1: 7.4±2.0 (0.75±0.2, 5.4±1.4)**

**T2: 32±10 (3.3±1.0, 24±7)**

## B: ABS CONTROL MODULE AND HYDRAULIC CONTROL UNIT (ABSCM&H/U)

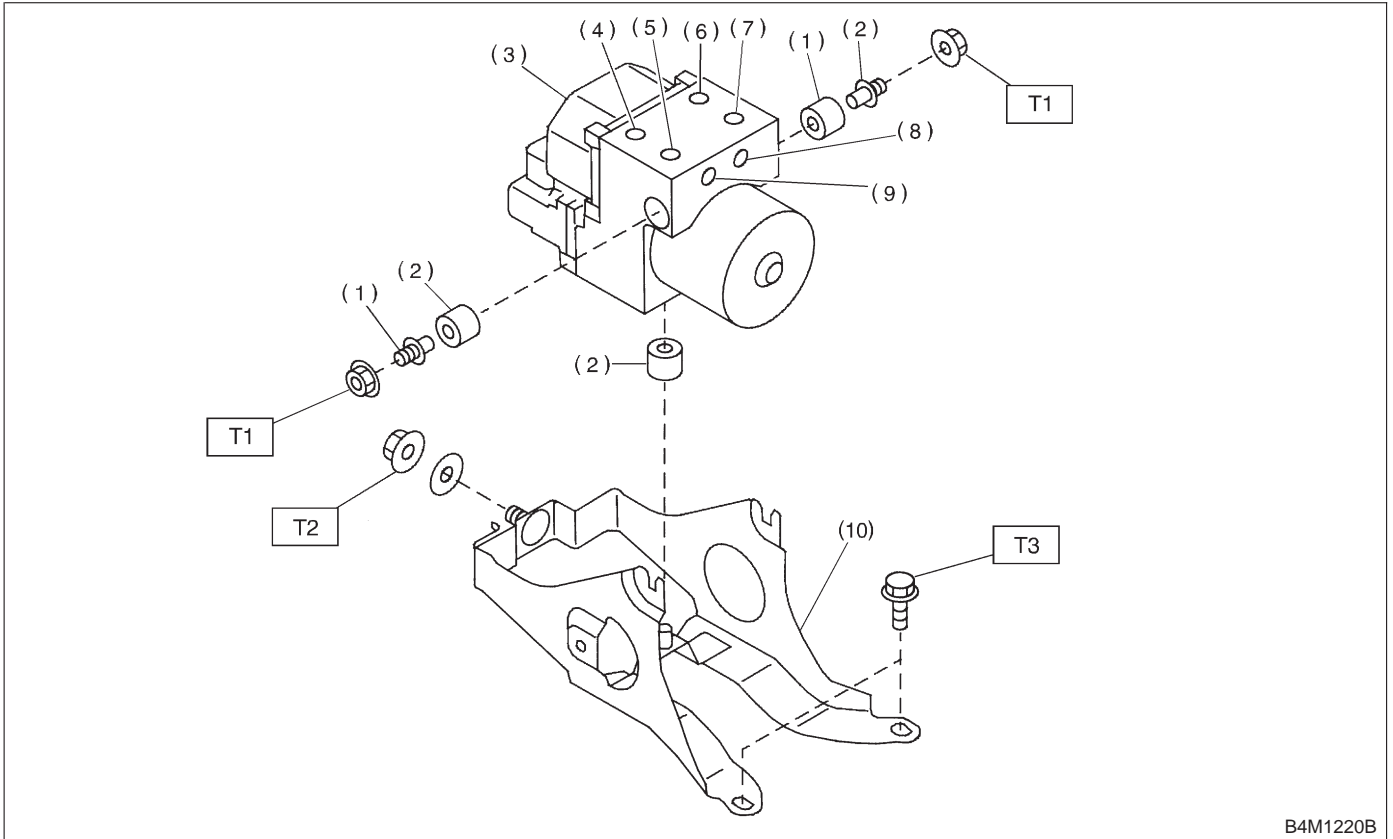

B4M1220B

- |   |                     |
|---|---------------------|
| (1) Stud bolt                                     | (6) Front-RH outlet |
| (2) Damper  | (7) Primary inlet   |
| (3) ABS control module and hydraulic control unit | (8) Rear-LH outlet  |
| (4) Front-LH outlet                               | (9) Rear-RH outlet  |
| (5) Secondary inlet                               | (10) Bracket        |

**Tightening torque: N·m (kg·m, ft·lb)**

**T1: 18±5 (1.8±0.5, 13.0±3.6)**

**T2: 29±7 (3.0±0.7, 21.7±5.1)**

**T3: 32±10 (3.3±1.0, 24±7)**