

F: INSTALLATION

- 1) Install disc rotor on hub.
- 2) Install support on housing.

Tightening torque:
78±10 N·m (8±1 kg-m, 58±7 ft-lb)

CAUTION:

- Always replace the pads for both the left and right wheels at the same time. Also replace pad clips if they are twisted or worn.
- A wear indicator is provided on the inner disc brake pad. If the pad wears down to such an extent that the end of the wear indicator contacts the disc rotor, a squeaking sound is produced as the wheel rotates. If this sound is heard, replace the pad.
- When replacing the pad, replace pads of the right and left wheels at the same time.

- 3) Apply thin coat of PBC GREASE (Part No. 003607000) to the frictional portion between pad and pad clip.

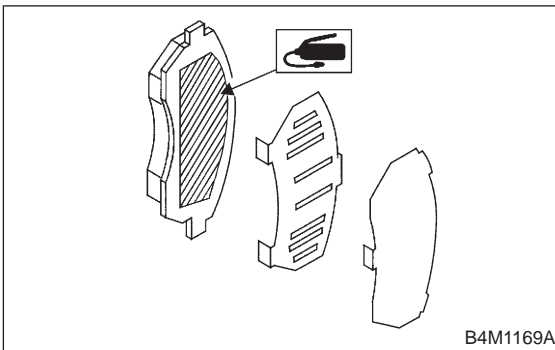

- 4) Install pads, rubber coated shim and stainless shim on support.
- 5) Install caliper body on support.

Tightening torque:
39±5 N·m (4±0.5 kg-m, 28.9±3.6 ft-lb)

- 6) Connect brake hose.

Tightening torque:
18±3 N·m (1.8±0.3 kg-m, 13.0±2.2 ft-lb)

CAUTION:

Replace brake hose gaskets with new ones.

- 7) Bleed air from brake system.

2. Rear Disc Brake

A: ON-CAR SERVICE

1. PAD

- 1) Remove lock pin.

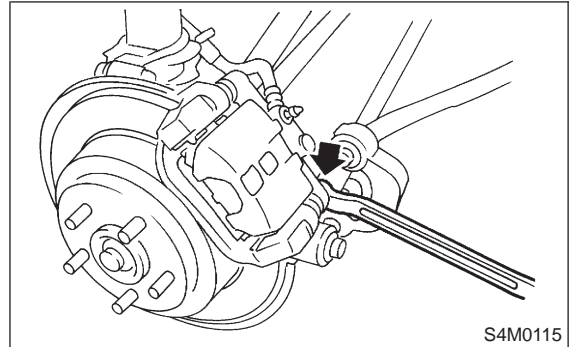

- 2) Raise caliper body.
- 3) Remove pad from support.

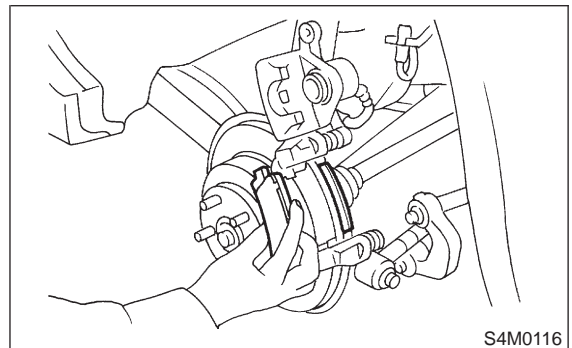

4) Check pad thickness (including back metal).

CAUTION:

- Always replace the pads for both the left and right wheels at the same time. Also replace pad clips if they are twisted or worn.
- A wear indicator is provided on the inner disc brake pad. If the pad wears down to such an extent that the end of the wear indicator contacts the disc rotor, a squeaking sound is produced as the wheel rotates. If this sound is heard, replace the pad.
- Replace pad if there is oil or grease on it.

Pad thickness: A

- Standard value**
15.0 mm (0.591 in)
- Wear limit**
6.5 mm (0.256 in)

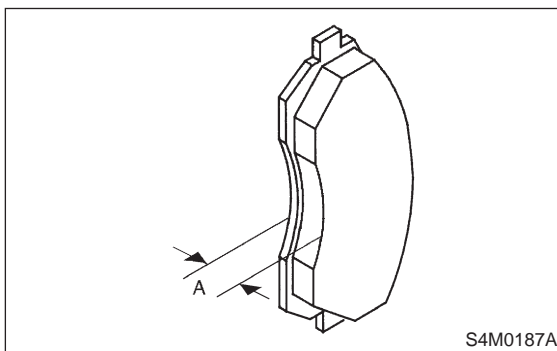

- 5) Apply thin coat of PBC GREASE (Part No. 03607000) to the frictional portion between pad and pad clip.
- 6) Install pad on support.
- 7) Install caliper body on support.

Tightening torque:

20±4 N·m (2.0±0.4 kg·m, 14.5±2.9 ft·lb)

NOTE:

If it is difficult to push piston during pad replacement, loosen air bleeder to facilitate work.

2. DISC ROTOR

- 1) Install disc rotor by tightening the five wheel nuts.
- 2) Set a dial gauge on the disc rotor. Turn disc rotor to check runout.

NOTE:

Make sure that dial gauge is set 5 mm (0.20 in) inward of rotor outer perimeter.

Disc rotor runout limit:
0.1 mm (0.004 in)

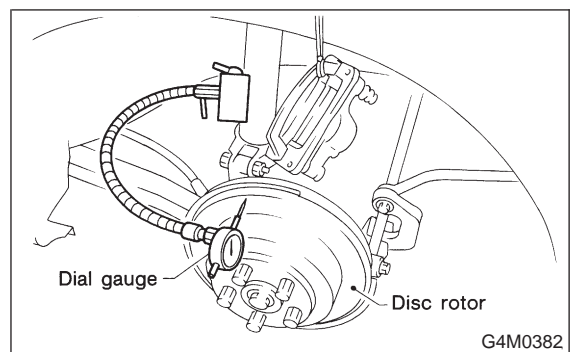

3) Measure disc rotor thickness.

NOTE:

- Make sure that micrometer is set 5 mm (0.20 in) inward of rotor outer perimeter.
- When removing disc rotor, refer to instructions under Parking Brake. <Ref. to 4-4 [W4A0].>

Disc rotor thickness: A

- Standard value**
10 mm (0.39 in)
- Service limit**
8.5 mm (0.335 in)

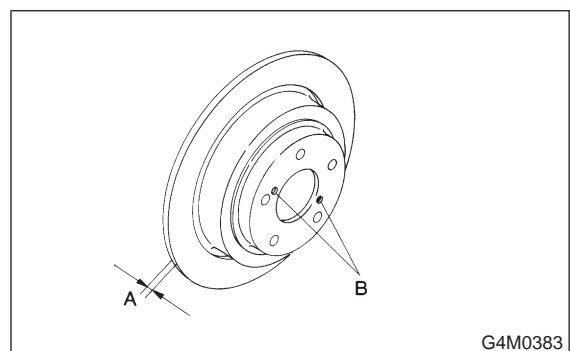

B: REMOVAL

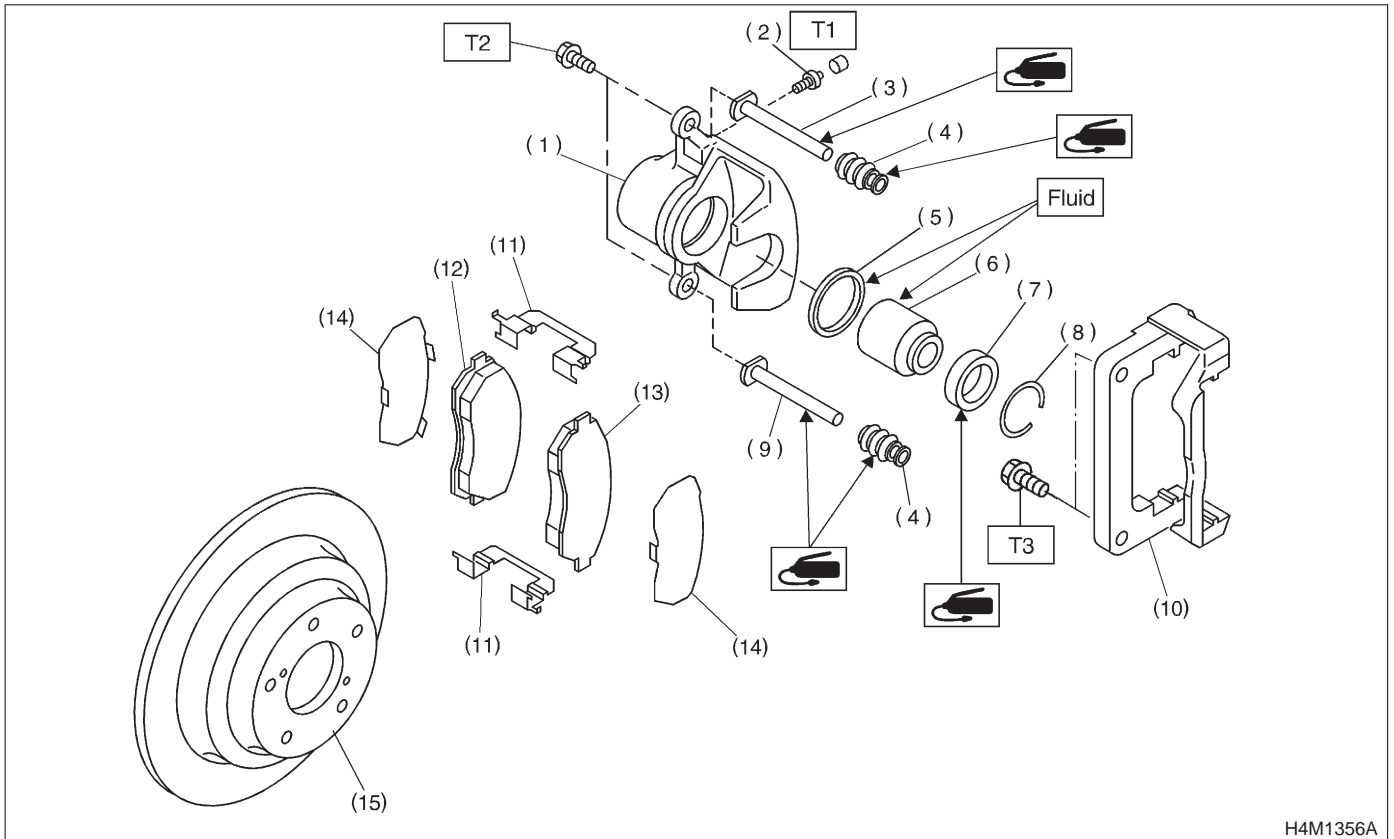

- | | |
|-----------------------|-----------------------|
| (1) Caliper body | (8) Boot ring |
| (2) Air bleeder screw | (9) Lock pin (Yellow) |
| (3) Guide pin (Green) | (10) Support |
| (4) Pin boot | (11) Pad clip |
| (5) Piston seal | (12) Inner pad |
| (6) Piston | (13) Outer pad |
| (7) Piston boot | (14) Shim |

- (15) Disc rotor

Tightening torque: N-m (kg-m, ft-lb)

T1: 8±1 (0.8±0.1, 5.8±0.7)

T2: 39±5 (4.0±0.5, 28.9±3.6)

T3: 52±6 (5.3±0.6, 38.3±4.3)

- 1) Lift-up vehicle and remove wheels.
- 2) Disconnect brake hose from caliper body assembly.

CAUTION:
Do not allow brake fluid to come in contact with vehicle body; wipe off completely if spilled.

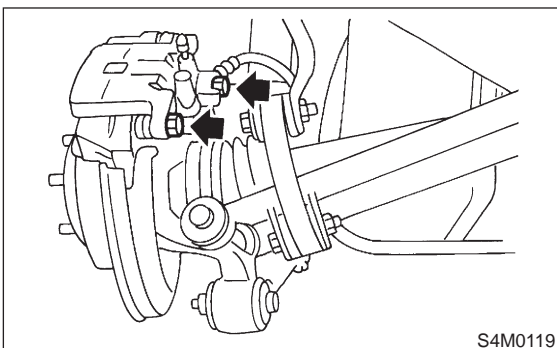

- 3) Remove lock pin.

- 4) Raise caliper body and move it toward vehicle center to separate it from support.
- 5) Remove support from back plate.

NOTE:
Remove support only when replacing it or the rotor. It need not be removed when servicing caliper body assembly.

- 6) Clean mud and foreign particles from caliper body assembly and support.

CAUTION:
Be careful not to allow foreign particles to enter inlet (at brake hose connector).

C: DISASSEMBLY

1) Remove the boot ring.

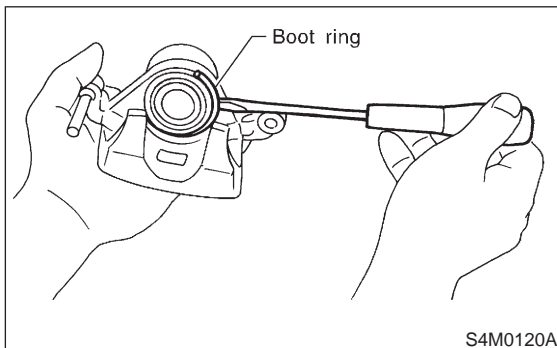

2) Remove the piston boot.

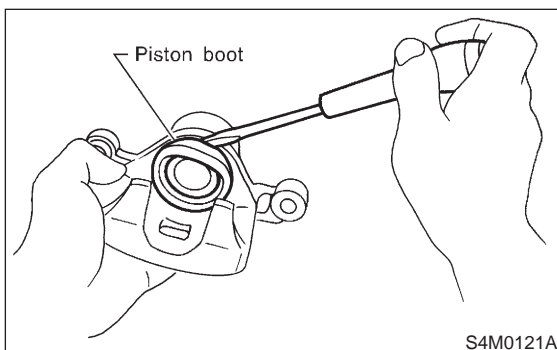

3) Gradually supply compressed air via inlet of caliper body to force piston out.

CAUTION:

- Place a wooden block as shown in Figure to prevent damage to piston.
- Do not apply excessively high-pressure.

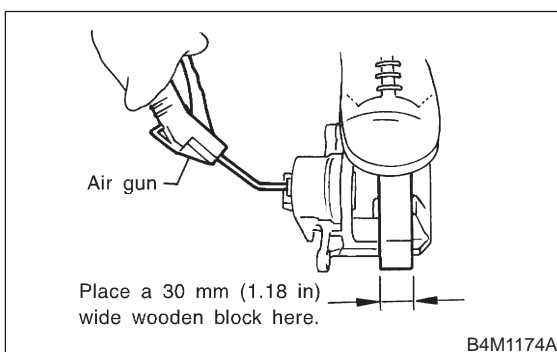

4) Remove piston seal from caliper body cylinder.

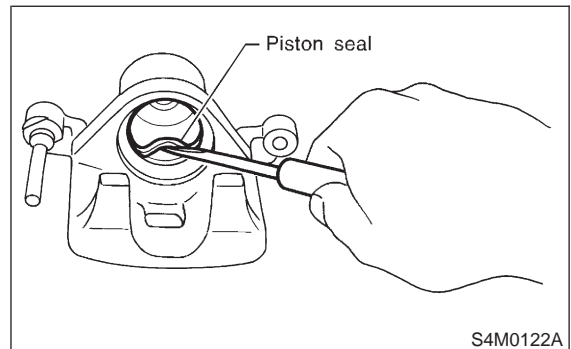

5) Remove lock pin sleeve and boot from caliper body.

6) Remove guide pin boot.

D: INSPECTION

- 1) Repair or replace faulty parts.
- 2) Check caliper body and piston for uneven wear, damage or rust.
- 3) Check rubber parts for damage or deterioration.

E: ASSEMBLY

- 1) Clean caliper body interior using brake fluid.
- 2) Apply a coat of brake fluid to piston seal and fit piston seal in groove on caliper body.
- 3) Apply a coat of brake fluid to the entire inner surface of cylinder and outer surface of piston.
- 4) Insert piston into cylinder.

CAUTION:

Do not force piston into cylinder.

- 5) Apply a coat of specified grease to boot and fit in groove on ends of cylinder and piston.

Grease

NIGLUBE RX-2 (Part No. 003606000)

- 6) Install the piston boot to the caliper body, and attach boot ring.

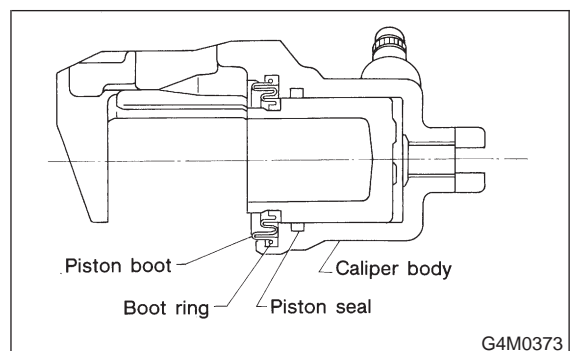

7) Apply a coat of specified grease to guide pin, outer surface, sleeve outer surface, cylinder inner surface, and boot grooves.

Grease

NIGLUBE RX-2 (Part No. 003606000)

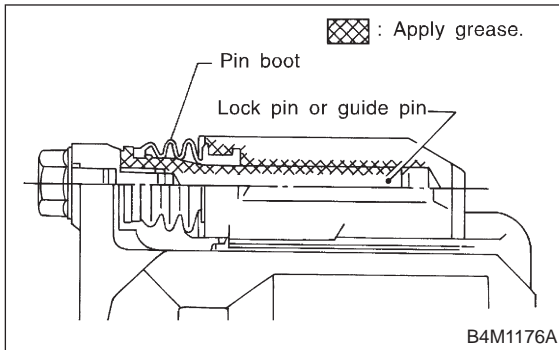

- 8) Install guide pin boot on caliper body.
 9) Install lock pin boot on caliper body and insert lock pin sleeve into place.

F: INSTALLATION

- 1) Install disc rotor on hub.
- 2) Install support on back plate.

Tightening torque:

$52 \pm 6 \text{ N}\cdot\text{m}$ ($5.3 \pm 0.6 \text{ kg}\cdot\text{m}$, $38.3 \pm 4.3 \text{ ft}\cdot\text{lb}$)

CAUTION:

- Always replace the pads for both the left and right wheels at the same time. Also replace pad clips if they are twisted or worn.

- A wear indicator is provided on the inner disc brake pad. If the pad wears down to such an extent that the end of the wear indicator contacts the disc rotor, a squeaking sound is produced as the wheel rotates. If this sound is heard, replace the pad.

- Replace pads if there is oil or grease on them.

- 3) Apply thin coat of PBC GREASE (Part No. 003607000) to the frictional portion between pad and pad clip.
- 4) Install pads on support.
- 5) Install caliper body on support.

Tightening torque:

$20 \pm 4 \text{ N}\cdot\text{m}$ ($2.0 \pm 0.4 \text{ kg}\cdot\text{m}$, $14.5 \pm 2.9 \text{ ft}\cdot\text{lb}$)

- 6) Connect brake hose.

Tightening torque:

$18 \pm 3 \text{ N}\cdot\text{m}$ ($1.8 \pm 0.3 \text{ kg}\cdot\text{m}$, $13.0 \pm 2.2 \text{ ft}\cdot\text{lb}$)

CAUTION:

- The brake hose must be connected without any twist.

- Replace brake hose gaskets with new ones.

- 7) Bleed air from brake system.