

1. Power Steering

A: STEERING CONDITION

Trouble	Possible cause	Corrective action
<ul style="list-style-type: none"> ● Heavy steering effort in all ranges ● Heavy steering effort at stand still ● Steering wheel surges when turning. 	1. Pulley belt <ul style="list-style-type: none"> ● Unequal length of pulley belts ● Adhesion of oil and grease ● Loose or damage of pulley belt ● Poor uniformity of pulley belt cross section ● Pulley belt touches to pulley bottom ● Poor revolution of pulleys except oil pump pulley ● Poor revolution of oil pump pulley 	Adjust or replace.
	2. Tire and rim <ul style="list-style-type: none"> ● Improper tires out of specification ● Improper rims out of specification ● Tires not properly inflated*1 	Replace or reinflate.
	3. Fluid <ul style="list-style-type: none"> ● Low fluid level ● Aeration ● Dust mix ● Deterioration of fluid ● Poor warming-up of fluid *2 	Refill, bleed air, replace or instruct customer.
	4. Idling speed <ul style="list-style-type: none"> ● Lower idling speed ● Excessive drop of idling speed at start or at turning steering wheel *3 	Adjust or instruct customer.
	5. Measure hydraulic pressure. <Ref. to 4-3 [K1B0].>	Replace problem parts.
	6. Measure steering effort. <Ref. to 4-3 [K1C0].>	Adjust or replace.
<ul style="list-style-type: none"> ● Vehicle leads to one side or the other. ● Poor return of steering wheel to center ● Steering wheel surges when turning. 	1. Fluid line <ul style="list-style-type: none"> ● Folded hose ● Flattened pipe 	Reform or replace.
	2. Tire and rim <ul style="list-style-type: none"> ● Flat tire ● Mix use of different tires ● Mix use of different rims ● Abnormal wear of tire ● Unbalance of remained grooves ● Unbalance of tire pressure 	Fix or replace.
	3. Front alignment <ul style="list-style-type: none"> ● Improper or unbalance caster ● Improper or unbalance toe-in ● Loose connection of suspension 	Adjust or retighten.
	4. Others <ul style="list-style-type: none"> ● Damaged joint assembly ● Unbalanced height ● One-sided weight 	Replace, adjust or instruct customer.
	5. Measure steering effort. <Ref. to 4-3 [K1C0].>	Adjust or replace.

*1 If tires and/or rims are wider, the load to power steering system is the more. Accordingly, in a condition, for example before fluid warms-up, relief valve may work before maximum turning angle. In this case, steering effort may be heavy. When measured hydraulic pressure is normal, there is no abnormal thing.

*2 In cold weather, steering effort may be heavy due to increased flow resistance of cold fluid. After warming-up engine, turn steering wheel from stop to stop several times to warm-up fluid. Then if steering effort reduces normally, there is no abnormal thing.

*3 In cold weather or with insufficient warm-up of engine, steering effort may be heavy due to excessive drop of idling when turning steering wheel. In this case, it is recommended to start the vehicle with increasing engine speed than usual. Then if steering effort reduces normally, there is no abnormal thing.

B: MEASUREMENT OF HYDRAULIC PRESSURE

CAUTION:

● Be sure to complete all items aforementioned in “STEERING CONDITION”, prior to measuring hydraulic pressure. Otherwise, pressure can not be measured correctly. <Ref. to 4-3 [K1A0].>

● Do not leave the valve of pressure gauge closed or hold the steering wheel at stop end for 5 seconds or more in any case, as the oil pump may be damaged due to long keep of these conditions.

● Put cotton cloth waste at a place where fluid drops before pressure gauge is installed. Wipe off split fluid thoroughly after the measurement.

NOTE:

Keep engine idling during the measurement.

1B1 : MEASURE REGULAR PRESSURE.

- 1) Install STs to power steering pump.
 - (1) Drain the power steering fluid about 0.35 ℓ (0.4 US qt, 0.3 Imp qt) from oil tank.
 - (2) Remove two bolts securing power steering pipes to engine.
 - (3) Install ST1, 2 and 3 between power steering pump and pipes using gasket (Part No. 34621AC020) and bolt (Part No. 34620AC010).

ST1	925711000	PRESSURE GAUGE
ST2	34099AC020	ADAPTER HOSE B
ST3	34099AC010	ADAPTER HOSE A

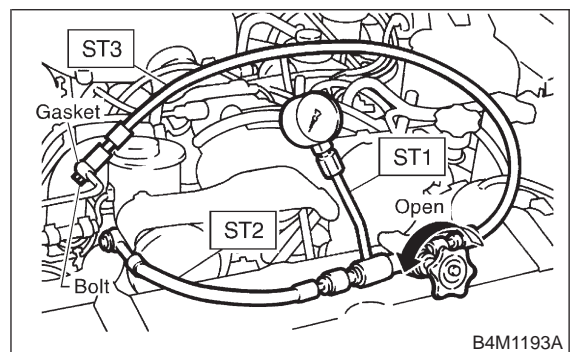

- (4) Replenish power steering fluid up to specified level.
- 2) Open valve, and start the engine.
- 3) Measure regular pressure.

CHECK : Is pressure 981 kPa (10 kg/cm², 142 psi) or less?

YES : Go to step 1B2.

NO : Trouble may be due to crushed pipe or hose, leakage from fluid line, foreign particles in fluid line, etc. Replace faulty parts with new ones.

4-3 [K1B2]

1. Power Steering

DIAGNOSTICS

1B2 : MEASURE RELIEF PRESSURE.

- 1) Using STs, measure relief pressure.
ST1 925711000 PRESSURE GAUGE
ST2 34099AC020 ADAPTER HOSE B
ST3 34099AC010 ADAPTER HOSE A

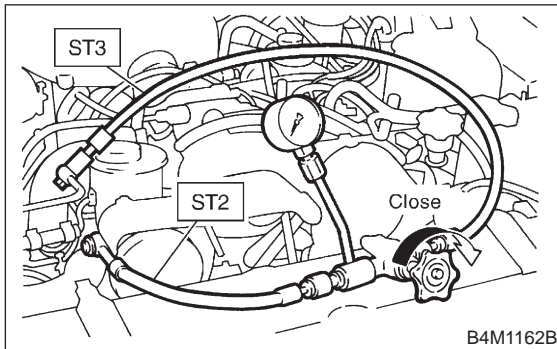

- 2) Close valve.

- CHECK** : **Is pressure 7,159 — 7,748 kPa (73 — 79 kg/cm², 1,038 — 1,123 psi)?**
- YES** : Go to step 1B3.
- NO** : Trouble may be due to malfunctioning relief valve, fluid leaking into oil pump interior, abnormal wear of pump vanes, etc. Replace faulty parts with new ones.

1B3 : MEASURE WORKING PRESSURE.

- 1) Using STs, measure working pressure.
ST1 925711000 PRESSURE GAUGE
ST2 34099AC020 ADAPTER HOSE B
ST3 34099AC010 ADAPTER HOSE A

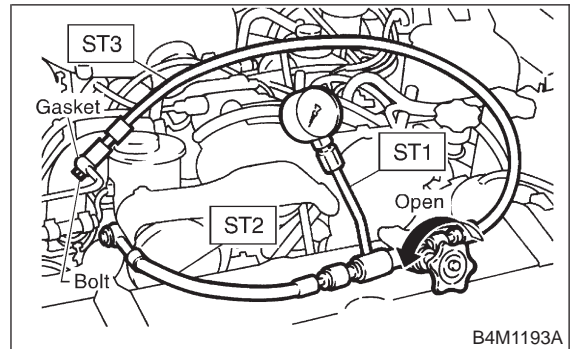

- 2) Open valve.
3) Measure working pressure of control valve by turning wheel from stop to stop.

- CHECK** : **Is pressure 7,159 — 7,748 kPa (73 — 79 kg/cm², 1,038 — 1,123 psi)?**
- YES** : Measure steering force. <Ref. to 4-3 [K1C0].>
- NO** : Control valve is inoperative. Replace control valve itself or control valve and pinion as a single unit with new ones.

C: MEASUREMENT OF STEERING EFFORT

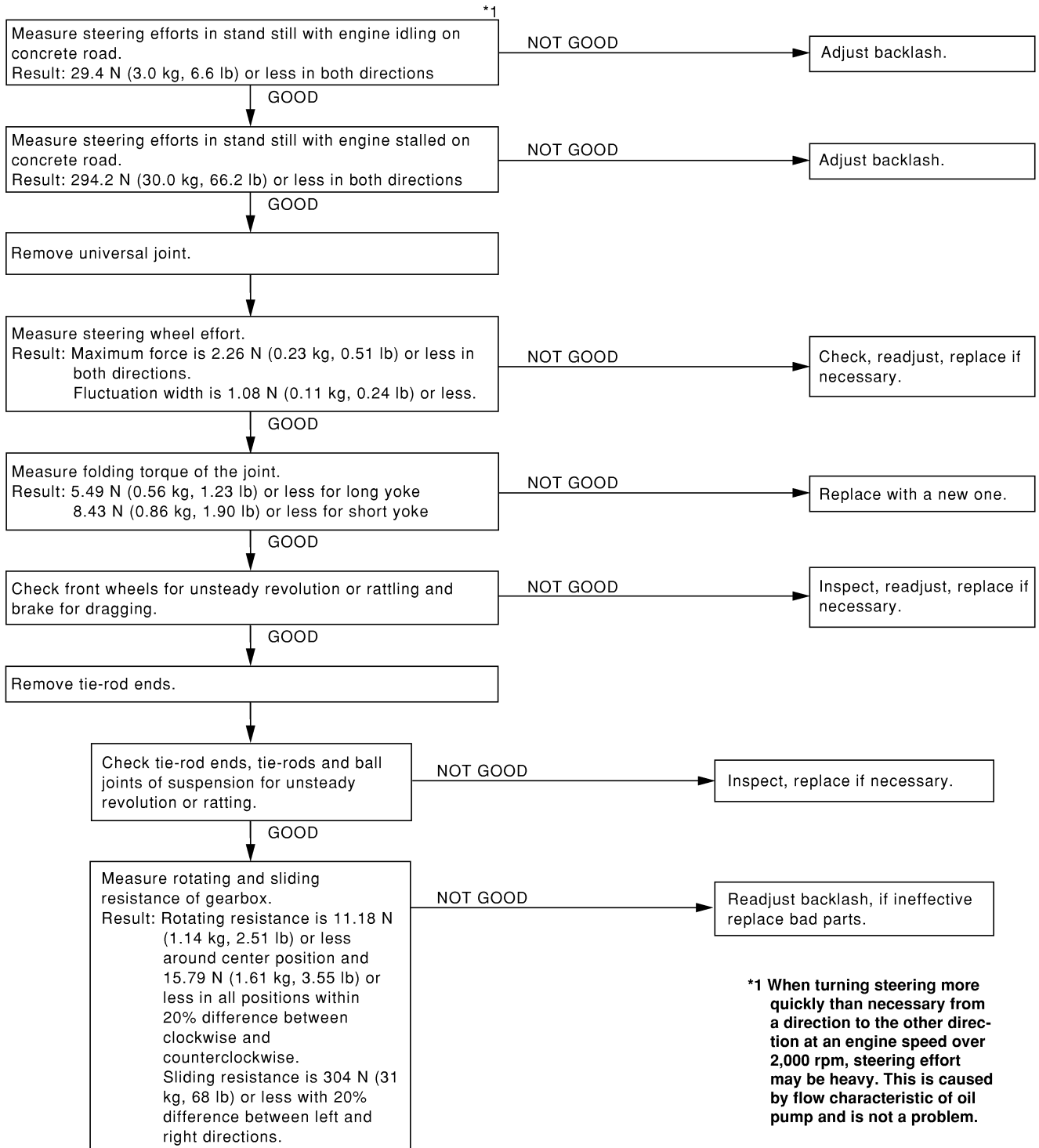

4-3 [K1C0]

1. Power Steering

DIAGNOSTICS

1) Measurement of steering effort is as shown in the figures.

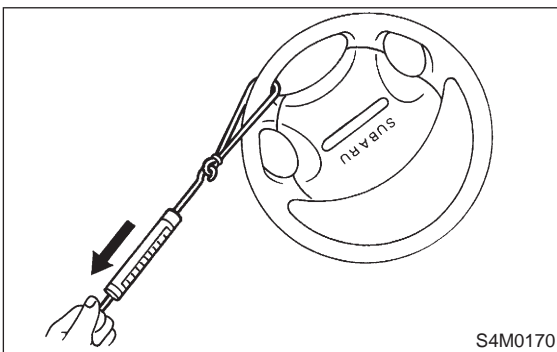
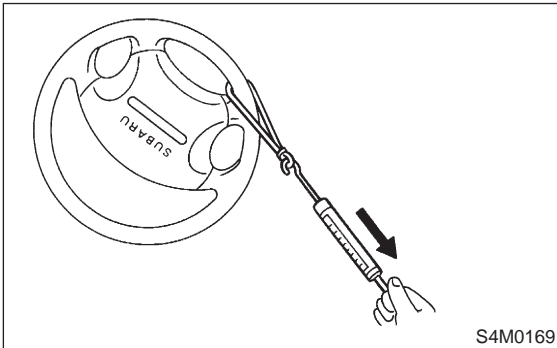

2) Measurement of folding torque of universal joint is as shown in the figures.

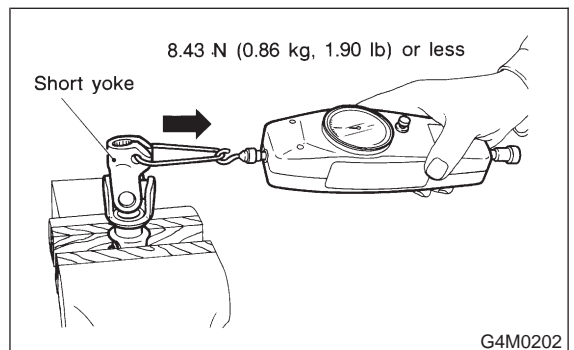
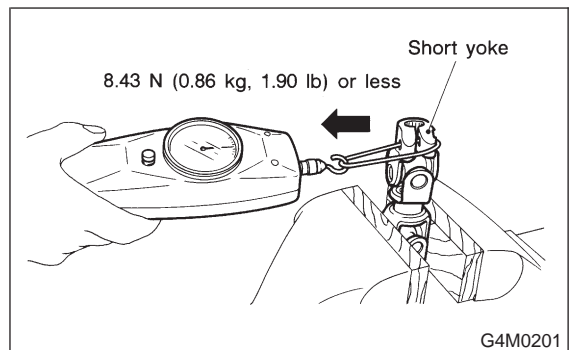
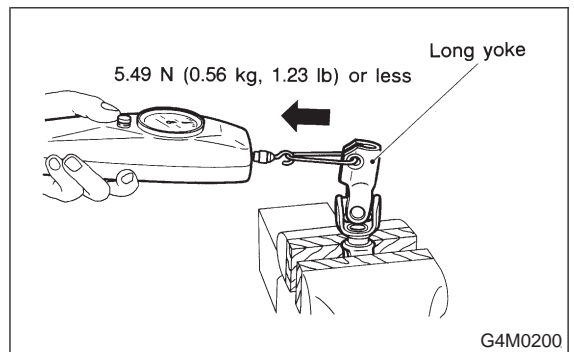
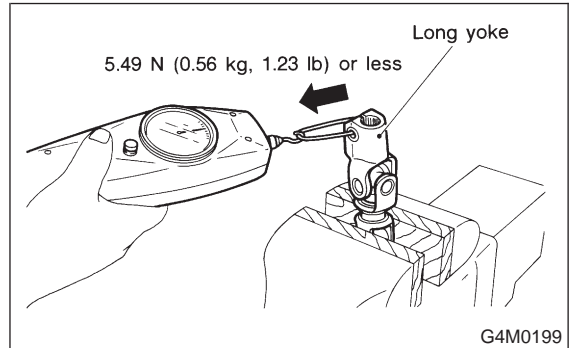

3) Using ST, measure resistances of gearbox.
ST 926230000 SPANNER

Rotating resistance:

Straight-ahead position within 30 mm (1.18 in) from rack center;

Less than 11.18 N (1.14 kg, 2.51 lb)

Maximum allowable torque;

12.7 N (1.3 kg, 2.9 lb)

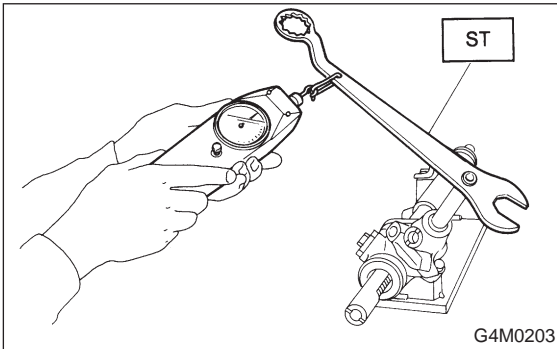

Left-turn steering;

304 N (31 kg, 68 lb) or less

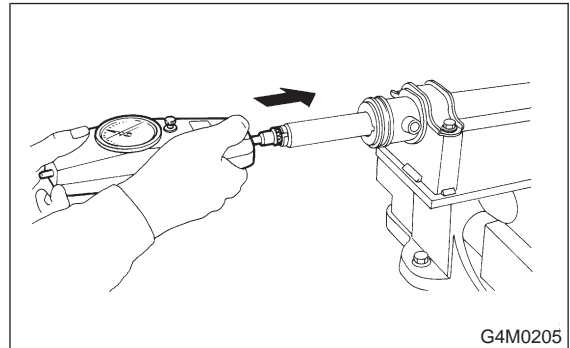

Sliding resistance:

Right-turn steering;

304 N (31 kg, 68 lb) or less

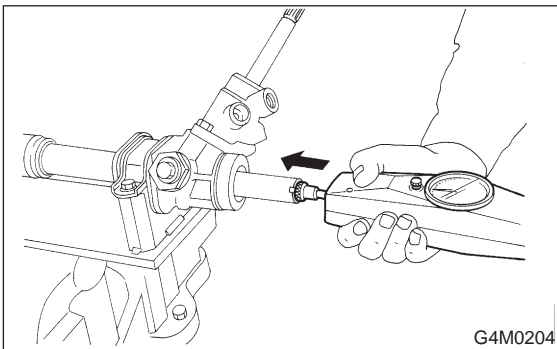

D: FLUID LEAKAGE

CAUTION:

It is likely that although one judges fluid leakage, there is actually no leakage. This is because the fluid spilt during the last maintenance was not completely wiped off. Be sure to wipe off spilt fluid thoroughly after maintenance.

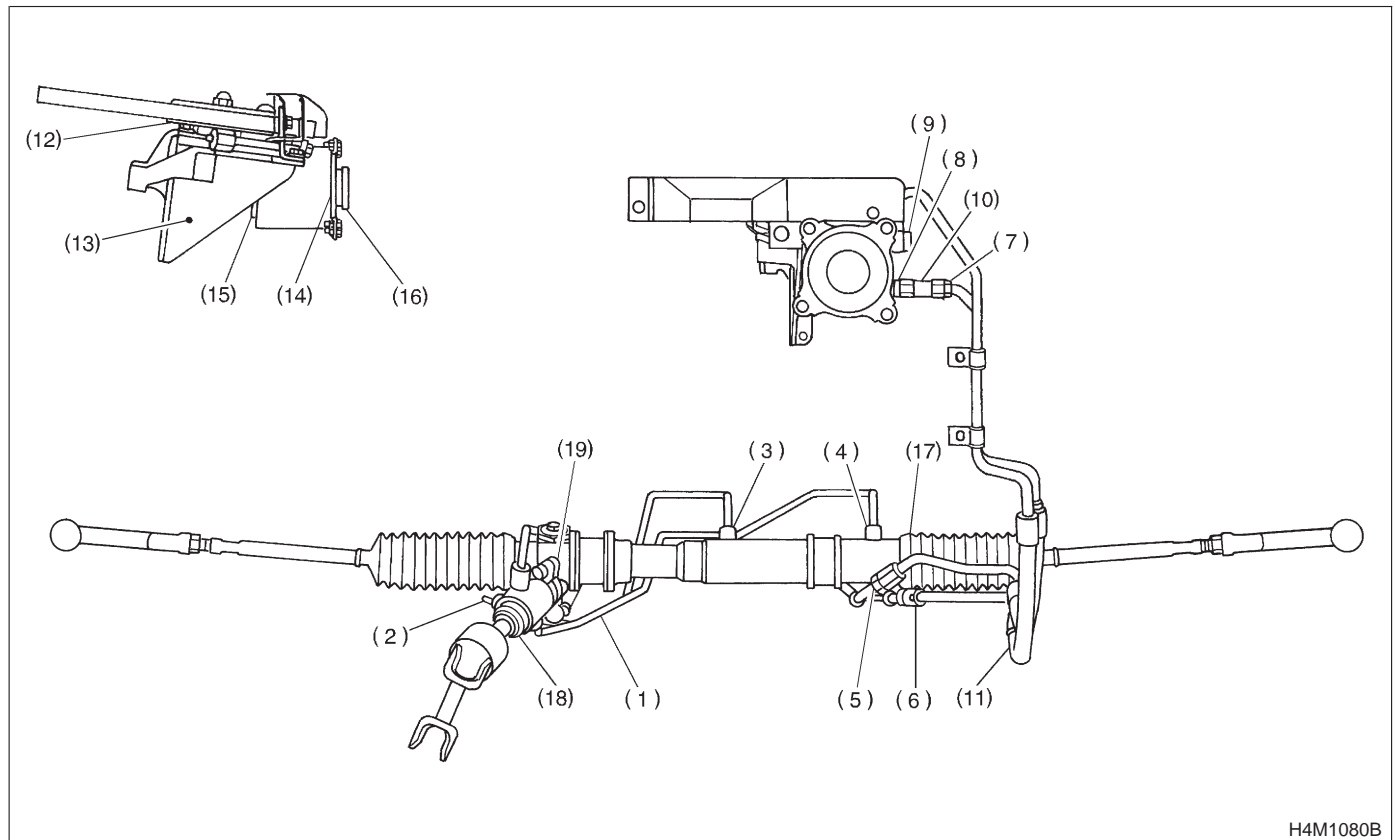

H4M1080B

Fluid leaking area	Possible cause	Corrective action
Leakage from connecting portions of pipes and hoses, numbered with (1) through (9) in figure	Insufficient tightening of flare nut, catching dirt or the like, damage to flare or flare nut	Loosen and retighten, if ineffective, replace.
	Poor insertion of hose, poor clamping	Retighten or replace clamp.
	Damaged O-ring	Replace O-ring pipe or hose with new one, if ineffective, replace gearbox also.
Leakage from hose (10) and (11) in figure	Crack or damage in hose	Replace with a new one.
	Crack or damage in hose hardware	Replace with a new one.
Leakage from surrounding of cast iron portion of oil pump (12) and (13) in figure	Damaged O-ring	Replace O-ring.
	Damaged gasket	Replace gasket.
Leakage from oil tank (14) and (15) in figure	Crack in oil tank, (14)	Replace oil tank.
	Damaged O-ring, (15)	Replace O-ring.
Leakage from filler neck (16)	Damaged cap packing	Replace cap.
	Crack in root of filler neck	Replace oil tank.
	High fluid level *1	Adjust fluid level.
Leakage from surrounding of power cylinder of gearbox (17) in figure	Damaged oil seal	Replace oil seal.
Leakage from control valve of gearbox (18) and (19) in figure	Damaged packing or oil seal	Replace problem parts.
	Damage in control valve	Replace control valve.

Fluid level is specified at optimum position (range) for ordinary use. Accordingly, if the vehicle is used often under hard conditions such as on very rough roads or in mountainous areas, fluid may bleed out from cap air vent hole. This is not a problem. If a customer complains strongly and is not likely to be satisfied with the leakage, lower the fluid level to the extent that fluid will not bleed out under the conditions described, and have the customer check the fluid level and its quality more frequency than usual.

E: NOISE AND VIBRATION

CAUTION:

Don't keep the relief valve operated over 5 seconds at any time or inner parts of the oil pump may be damaged due to rapid increase of fluid temperature.

NOTE:

- Grinding noise may be heard immediately after the engine start in extremely cold condition. In this case, if the noise goes off during warm-up there is no abnormal function in the system. This is due to the fluid characteristic in extremely cold condition.
- Oil pump makes whine or growl noise slightly due to its mechanism. Even if the noise can be heard when steering wheel is turned at stand still there is no abnormal function in the system provided that the noise eliminates when the vehicle is running.
- When stopping with service brake and/or parking brake applied, power steering can be operated easily due to its light steering effort. If doing so, the

disk rotates slightly and makes creaking noise. The noise is generated by creaking between the disk and pads. If the noise goes off when the brake is released, there is no abnormal function in the system.

- There may be a little vibration around the steering devices when turning steering wheel at standstill, even though the component parts are properly adjusted and have no defects.

Hydraulic systems are likely to generate this kind of vibration as well as working noise and fluid noise because of combined conditions, i.e., road surface and tire surface, engine speed and turning speed of steering wheel, fluid temperature and braking condition.

This phenomena does not indicate there is some abnormal function in the system.

The vibration can be known when steering wheel is turned repeatedly at various speeds from slow to rapid step by step with parking brake applied on concrete road and in "D" range for automatic transmission vehicle.

4-3 [K1E0]

1. Power Steering

DIAGNOSTICS

Trouble	Possible cause	Corrective action
Hiss noise (continuous) While engine is running.	Relief valve emits operating sound when steering wheel is completely turned in either direction. (Don't keep this condition over 5 seconds.)	Normal
	Relief valve emits operating sound when steering wheel is not turned. This means that the relief valve is faulty.	Defective Replace oil pump.
Rattling noise (intermittent) While engine is running.	Interference with adjacent parts	Check clearance. Correct if necessary. <Ref. to 4-3 [K1F0].>
	Loosened installation of oil pump, oil tank, pump bracket, gearbox or crossmember	Retighten.
	Loosened installation of oil pump pulley or other pulley(s)	Retighten.
	Loosened linkage or play of steering or suspension Loosened tightening of joint or steering column	Retighten or replace.
	Sound generates from the inside of gearbox or oil pump.	Replace the gearbox or oil pump.
Knocking When turning steering wheel in both direction with small angle repeatedly at engine ON or OFF.	Excessive backlash Loosened lock nut for adjusting backlash	Adjust and retighten.
	Loosened tightening or play of tie-rod, tie-rod end	Retighten or replace.
Grinding noise (continuous) While engine is running.	Vane pump aeration	Inspect and retighten fluid line connection. Refill fluid and vent air.
	Vane pump seizing	Replace oil pump.
	Pulley bearing seizing of oil pump	Replace oil pump.
	Folded hose, flat pipe	Replace.
Squeal, squeak (intermittent or continuous) While engine is running.	Maladjustment of pulley belt Damaged or charged pulley belt Unequal length of pulley belts	Adjust or replace. (Replace two belts as a set.)
	Run out or soilage of V-groove surface of oil pump pulley	Clean or replace.
Sizzling noise (continuous) While engine is running.	Fluid aeration	Fix wrong part causing aeration. Replace fluid and vent air.
	Damaged pipe of gearbox	Replace pipe.
	Abnormal inside of hose or pipe Flat hose or pipe	Rectify or replace.
	Abnormal inside of oil tank	Replace.
	Removed oil tank cap	Install cap.
Whistle (continuous) While engine is running.	Abnormal pipe of gearbox or abnormal inside of hose	Replace bad parts of gearbox or hose.
Whine or growl (continuous or intermittent) While engine is running with/without steering turned.	Loosened installation of oil pump, oil pump bracket	Retighten.
	Abnormal inside of oil pump, hose	Replace oil pump, hose, if the noise can be heard when running as well as stand still.
	Torque converter growl, air conditioner compression growl	Remove power steering pulley belt and confirm.
Creaking noise (intermittent) While engine is running with steering turned.	Abnormal inside of gearbox	Replace bad parts of gearbox.
	Abnormal bearing for steering shaft	Apply grease or replace.
	Generates when turning steering wheel with brake (service or parking) applied.	If the noise goes off when brake is released, it is normal.
Vibration While engine is running with/without steering turned.	Too low engine speed at start	Adjust and instruct customers.
	Vane pump aeration	Fix wrong part. Vent air.
	Damaged valve in oil pump, gearbox	Replace oil pump, bad parts of gearbox.
	Looseness of play of steering, suspension parts	Retighten.

F: CLEARANCE TABLE

CAUTION:

This table lists various clearances that must be correctly adjusted to ensure normal vehicle driving without interfering noise, or any other faults.

Location	Minimum allowance mm (in)
(1) Crossmember — Pipe	5 (0.20)
(2) DOJ — Shaft or joint	14 (0.55)
(3) DOJ — Valve housing	11 (0.43)
(4) Pipe — Pipe	2 (0.08)
(5) Stabilizer — Pipe	5 (0.20)
(6) Exhaust pipe — Pipe	15 (0.59)
(7) Exhaust pipe — Gearbox bolt	15 (0.59)
(8) Side frame — Hose A and B	15 (0.59)
(9) Cruise control pump — Hose A and B	15 (0.59)
(10) Pipe portion of hose A — Pipe portion of hose B	1.5 (0.059)
(11) AT cooling hose — Joint	20 (0.79)

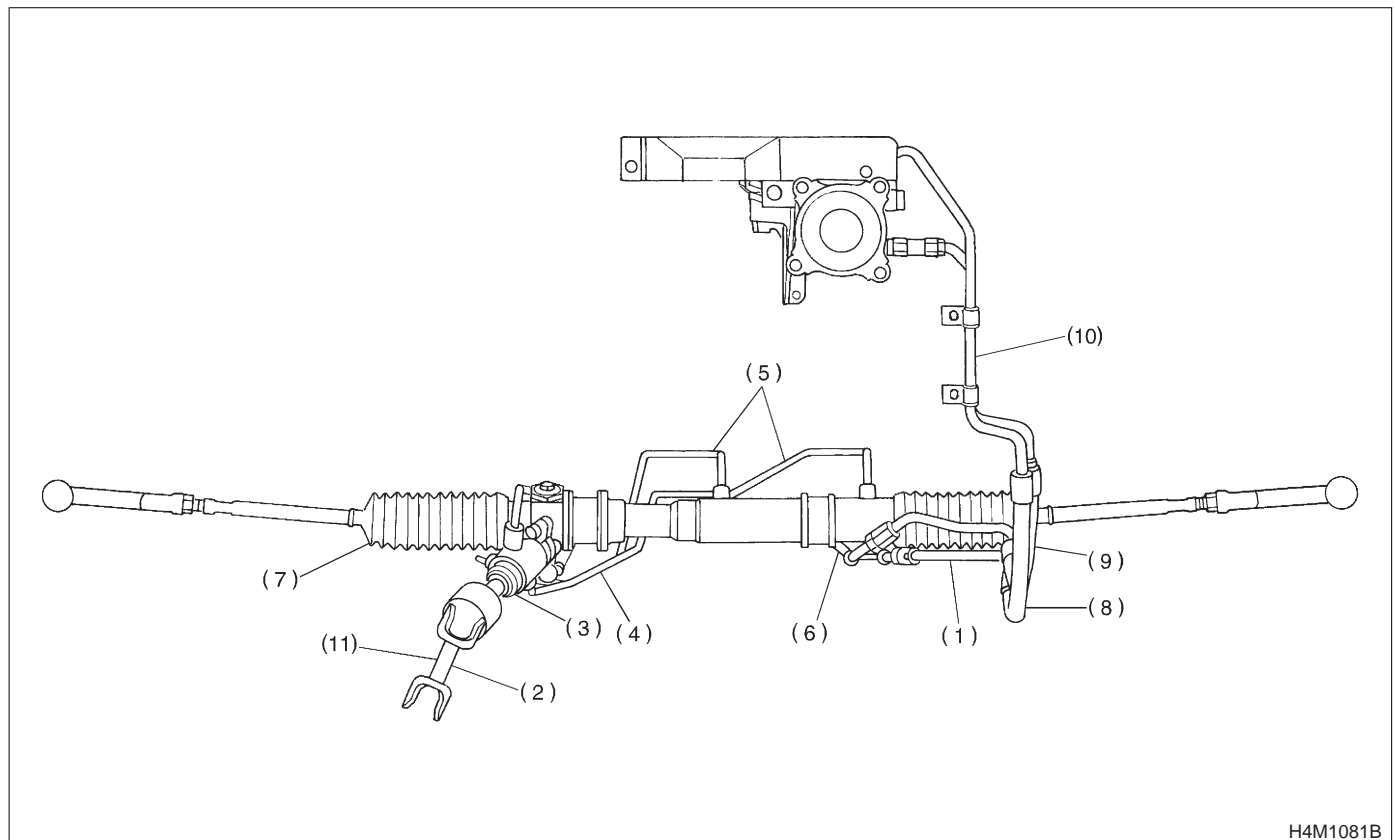

H4M1081B

G: BREAKAGE OF HOSES

CAUTION:

Although surface layer materials of rubber hoses have excellent weathering resistance, heat resistance and resistance for low temperature brittleness, they are likely to be damaged chemically by brake fluid, battery electrolyte, engine oil and automatic transmission fluid and their service lives are to be very shortened. It is very important to keep the hoses free from before mentioned fluids and to wipe out immediately when the hoses are adhered with the fluids.

Since resistances for heat or low temperature brittleness are gradually declining according to time accumulation of hot or cold conditions for

the hoses and their service lives are shortening accordingly, it is necessary to perform careful inspection frequently when the vehicle is used in hot weather areas, cold weather area and/or a driving condition in which many steering operations are required in short time.

Particularly continuous work of relief valve over 5 seconds causes to reduce service lives of the hoses, the oil pump, the fluid, etc. due to over heat.

So, avoid to keep this kind of condition when servicing as well as driving.

Trouble	Possible cause	Corrective action
Pressure hose burst	Excessive holding time of relief status	Instruct customers.
	Malfunction of relief valve	Replace oil pump.
	Poor cold characteristic of fluid	Replace fluid.
Forced out return hose	Poor connection	Correct.
	Poor holding of clip	Retighten.
	Poor cold characteristic of fluid	Replace fluid.
Fluid bleeding out of hose slightly	Wrong layout, tensioned	Replace hose.
	Excessive play of engine due to deterioration of engine mounting rubber	Replace defective parts.
	Improper stop position of pitching stopper	Replace defective parts.
Crack on hose	Excessive holding time of relief status	Replace. Instruct customer.
	Excessive tightening torque for return hose clip	Replace.
	Power steering fluid, brake fluid, engine oil, electrolyte adhere on the hose surface	Replace. Pay attention on service work.
	Too many times use in extremely cold weather	Replace. Instruct customers.