

## 4-1 [W3A0]

### 3. Front Ball Joint

## SERVICE PROCEDURE

4) Connect stabilizer link to transverse link, and temporarily tighten bolts.

#### CAUTION:

Discard loosened self-locking nut and replace with a new one.

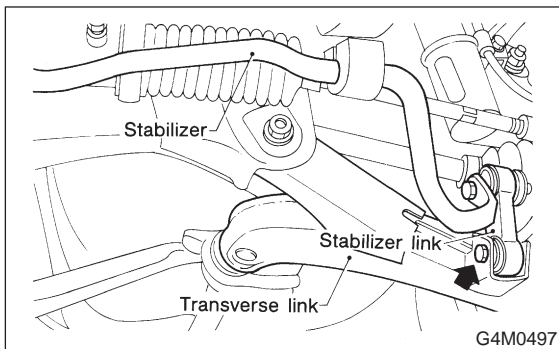

5) Tighten the following points in the order shown afterward when wheels are in full contact with the ground and vehicle is curb weight.

(1) Transverse link and stabilizer

#### Tightening torque:

$29 \pm 5 \text{ N}\cdot\text{m}$  ( $3.0 \pm 0.5 \text{ kg}\cdot\text{m}$ ,  $21.7 \pm 3.6 \text{ ft}\cdot\text{lb}$ )

(2) Transverse link and crossmember

#### Tightening torque:

$98 \pm 15 \text{ N}\cdot\text{m}$  ( $10.0 \pm 1.5 \text{ kg}\cdot\text{m}$ ,  $72 \pm 11 \text{ ft}\cdot\text{lb}$ )

(3) Transverse link rear bushing and body

#### Tightening torque:

$245 \pm 49 \text{ N}\cdot\text{m}$  ( $25 \pm 5 \text{ kg}\cdot\text{m}$ ,  $181 \pm 36 \text{ ft}\cdot\text{lb}$ )

#### NOTE:

- Move rear bushing back and forth until transverse link- to-rear bushing clearance is established (as indicated in figure.) before tightening.
- Check wheel alignment and adjust if necessary.

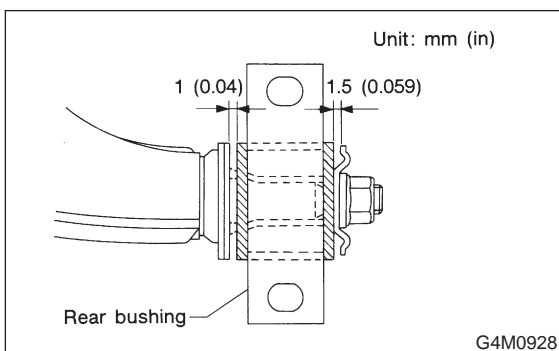

## 3. Front Ball Joint

### A: REMOVAL

- 1) Remove the wheels.
- 2) Pull out the cotter pin from the ball stud, remove the castle nut, and extract the ball stud from the transverse link.
- 3) Remove the bolt securing the ball joint to the housing.

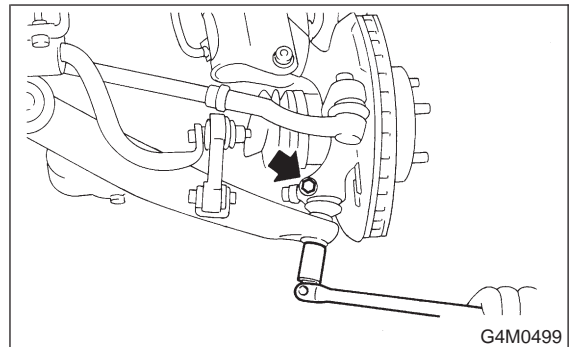

- 4) Extract the ball joint from the housing.

### B: INSPECTION

1) Measure play of ball joint by the following procedures. Replace with a new one when the play exceeds the specified value.

- (1) With 686 N (70 kg, 154 lb) loaded in the direction shown in the figure, measure dimension  $l_1$ .

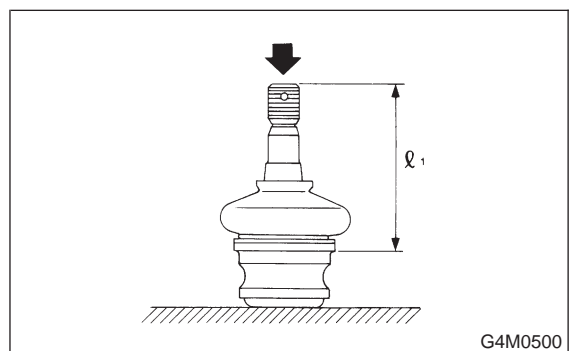

- (2) With 686 N (70 kg, 154 lb) loaded in the opposite direction shown in the figure, measure dimension  $l_2$ .

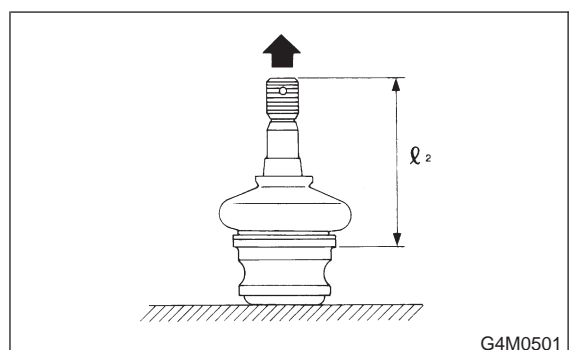

(3) Calculate plays from the following formula.

$$S = l_2 - l_1$$

(4) When plays is larger than the following value, replace with a new one.

#### **FRONT BALL JOINT**

**Specified play for replacement: S**  
**Less than 0.3 mm (0.012 in)**

2) When play is smaller than the specified value, visually inspect the dust cover.

3) The ball joint and cover that have been removed must be checked for wear, damage or cracks, and any defective part must be replaced.

4) If the dust cover is damaged, replace with the new ball joint.

### **C: INSTALLATION**

1) Install ball joint onto housing.

**Torque (Bolt):**

**49 N-m (5.0 kg-m, 36 ft-lb)**

**CAUTION:**

**Do not apply grease to tapered portion of ball stud.**

2) Connect ball joint to transverse link.

**Torque (Castle nut):**

**39 N-m (4.0 kg-m, 29 ft-lb)**

3) Retighten castle nut further within 60° until a slot in castle nut is aligned with the hole in ball stud end, then insert new cotter pin and bend it around castle nut.

4) Install front wheels.