

4-2 [W3A1]

3. Front and Rear Drive Shafts

SERVICE PROCEDURE

8) Connect rear ABS sensor to back plate (only vehicle equipped with ABS).

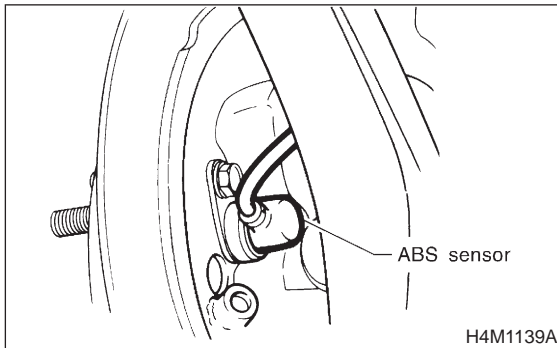

9) Connect parking brake cable to lever.

10) Install brake drum on rear housing assembly.

11) Bleed air from brake system. <Ref. to 4-4 [W10B0].>

12) Adjust parking brake lever stroke by turning adjuster.

13) Move brake lever back to apply brakes. While depressing brake pedal, tighten axle nut using a socket wrench. Lock axle nut after tightening.

Tightening torque:

186 ± 20 N·m (19 ± 2 kg·m, 137 ± 14 ft·lb)

CAUTION:

- Use a new axle nut.
- Always tighten axle nut before installing wheel on vehicle. If wheel is installed and comes in contact with ground when axle nut is loose, wheel bearings may be damaged.
- Be sure to tighten axle nut to specified torque. Do not overtighten it as this may damage wheel bearing.

14) Install wheel and tighten wheel nuts to specified torque.

Tightening torque:

88 ± 10 N·m (9 ± 1 kg·m, 65 ± 7 ft·lb)

3. Front and Rear Drive Shafts

A: REMOVAL

1. FRONT DRIVE SHAFT

- 1) Disconnect ground cable from battery.
- 2) Jack-up vehicle, support it with safety stands (rigid rocks), and remove front wheel cap and wheels.
- 3) Unlock axle nut.
- 4) Remove axle nut using a socket wrench.

CAUTION:

Be sure to loosen and retighten axle nut after removing wheel from vehicle. Failure to follow this rule may damage wheel bearings.

- 5) Disconnect transverse link from housing.
- 6) Remove spring pin which secures transmission spindle to SFJ.

CAUTION:

Use a new spring pin.

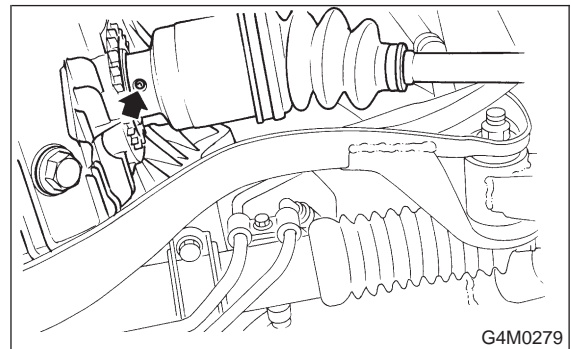

7) Remove front drive shaft assembly. If it is hard to remove, use ST1 and ST2.

ST1 926470000 AXLE SHAFT PULLER

ST2 927140000 PLATE

CAUTION:

- Be careful not to damage oil seal lip when removing front drive shaft.
- When front drive shaft is to be replaced, also replace inner oil seal.

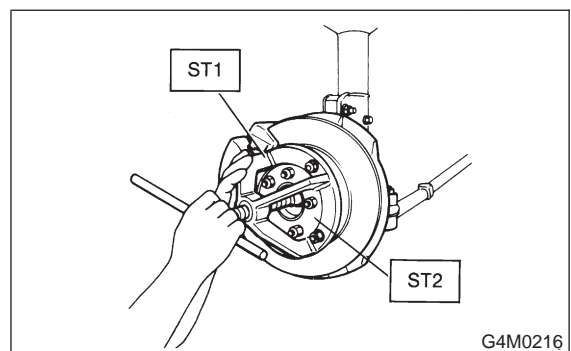

2. REAR DRIVE SHAFT

- 1) Disconnect ground cable from battery.
- 2) Lift-up vehicle, and remove rear wheel cap and wheels.

CAUTION:

Be sure to loosen and retighten axle nut after removing wheel from vehicle. Failure to follow this rule may damage wheel bearings.

- 3) Unlock axle nut.
- 4) Loosen axle nut using a socket wrench.

CAUTION:

Do not remove axle nut.

- 5) Remove ABS sensor clamps and parking brake cable bracket.
- 6) Remove bolts which secure lateral link assembly to rear housing.

CAUTION:

Discard old self-locking nut. Replace with a new one.

- 7) Remove bolts which secure trailing link assembly to rear housing.

CAUTION:

Discard old self-locking nut. Replace with a new one.

- 8) Remove DOJ from rear differential using ST. (Except 2200 cc AT vehicles)

ST 28099PA100 DRIVE SHAFT REMOVER

CAUTION:

Do not remove circlip attached to inside of differential.

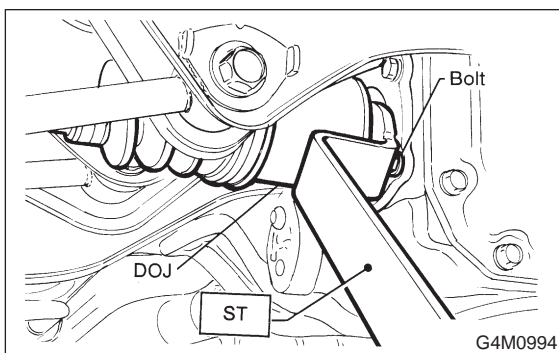

CAUTION:

Be careful not to damage side bearing retainer. Always use bolt as shown in figure, as supporting point for ST during removal.

ST 28099PA100 DRIVE SHAFT REMOVER

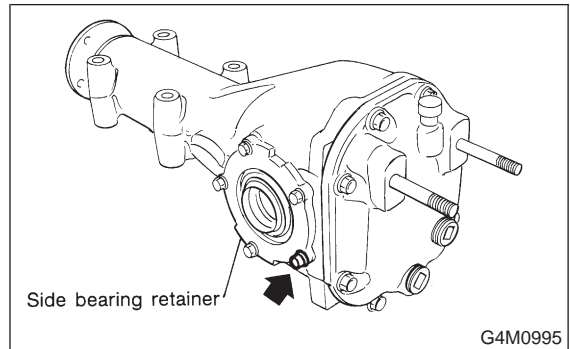

- 9) Remove DOJ from rear differential using tire lever. (2200 cc AT vehicles)

NOTE:

The side spline shaft circlip comes out together with the shaft.

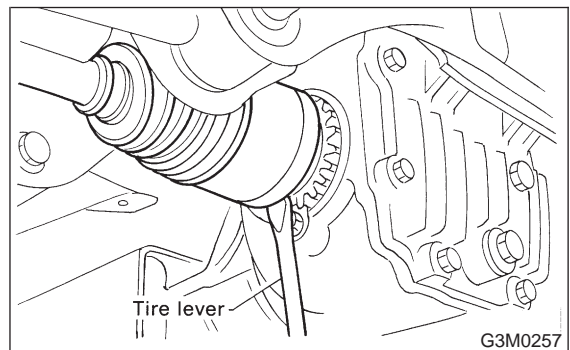

CAUTION:

When removing the DOJ from the rear differential, fit tire lever to the bolt as shown in figure so as not to damage the axle shaft holder.

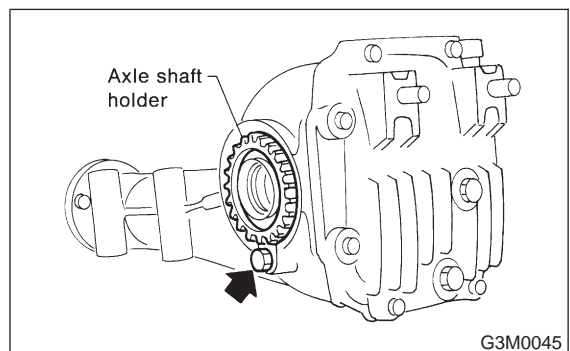

4-2 [W3B1]

3. Front and Rear Drive Shafts

SERVICE PROCEDURE

10) Remove axle nut and drive shaft. If it is hard to remove, use ST1 and ST2.

ST1 926470000 AXLE SHAFT PULLER

ST2 927140000 PLATE

CAUTION:

- Be careful not to damage oil seal lip when removing rear drive shaft.
- When rear drive shaft is to be replaced, also replace inner oil seal with a new one.

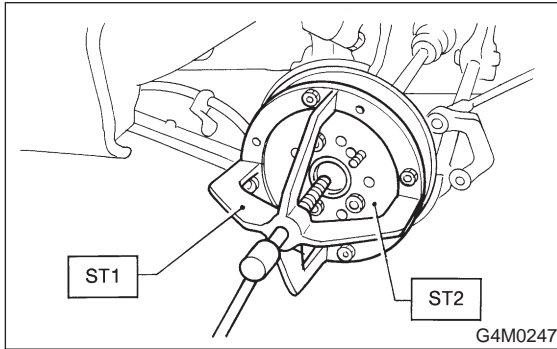

3) Remove circlip from SFJ outer race using screwdriver.

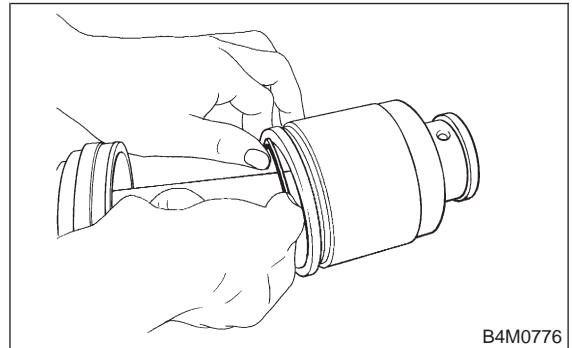

4) Remove SFJ outer race from shaft assembly.
5) Wipe off grease.

CAUTION:

The grease is a special grease. Do not confuse with other greases.

6) Place alignment mark on free ring and trunnion.

B: DISASSEMBLY

1. FRONT DRIVE SHAFT

1) Place alignment marks on shaft and outer race.

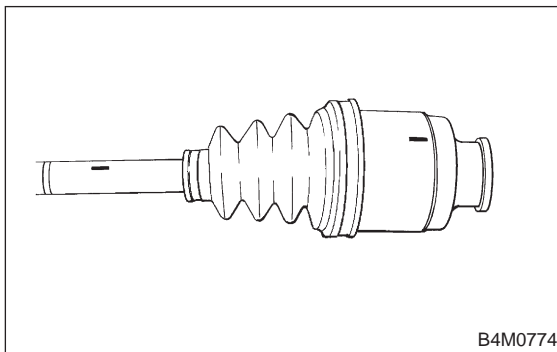

2) Remove SFJ boot band and boot.

CAUTION:

Be careful not to damage boot.

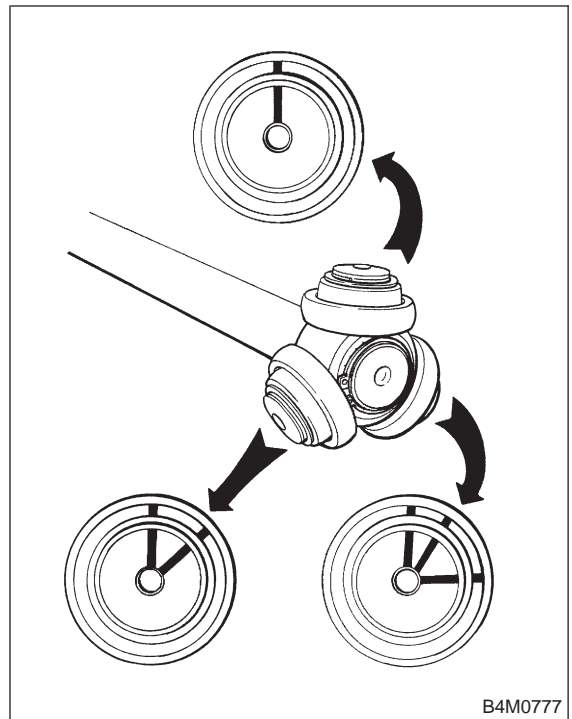
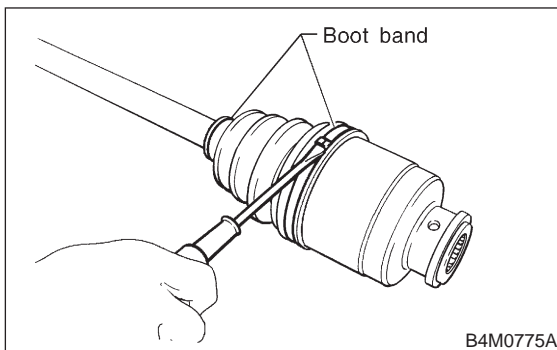

7) Remove free ring from trunnion.

8) Place alignment mark on trunnion and shaft.

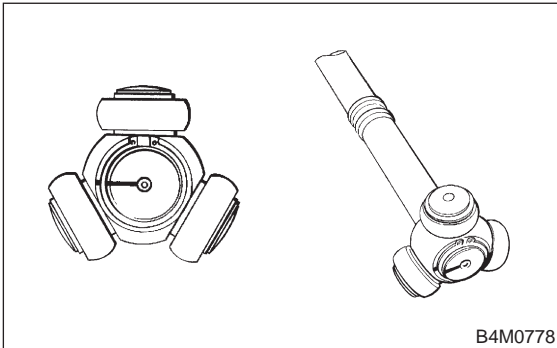

9) Remove snap ring and trunnion.

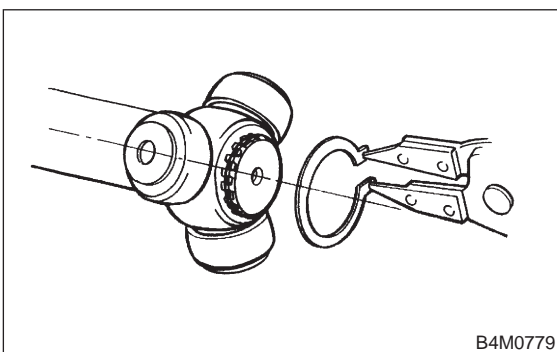

CAUTION:

Be sure to wrap shaft splines with vinyl tape to prevent boot from scratches.

10) Remove SFJ boot.

11) Place drive shaft in a vise between wooden blocks.

CAUTION:

Do not place drive shaft directly in the vise; use wooden block.

12) Raise boot band claws by means of screwdriver and hammer.

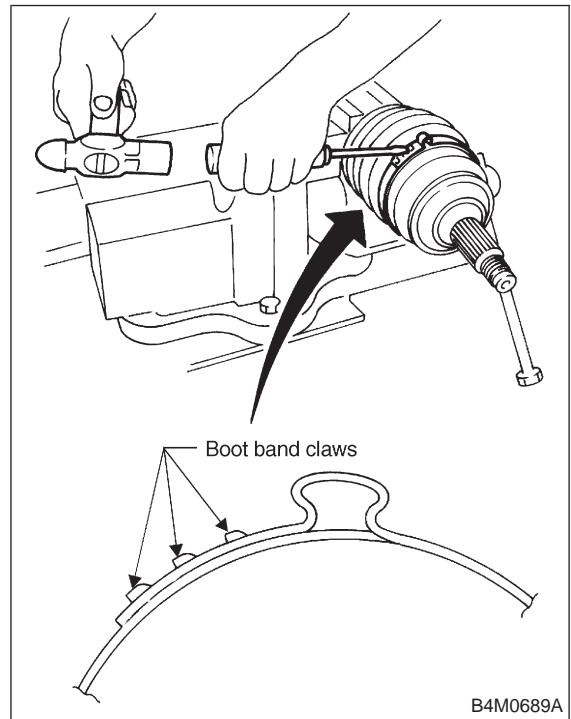

13) Cut and remove the boot.

CAUTION:

The boot must be replaced with a new one whenever it is removed.

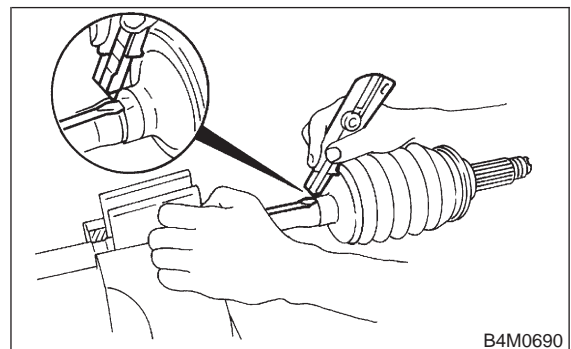

14) Thus, disassembly of axle is completed, but BJ cannot be disassembled.

2. REAR DRIVE SHAFT

1) Straighten bent claw of larger end of DOJ boot.

4-2 [W3C0]

3. Front and Rear Drive Shafts

SERVICE PROCEDURE

2) Loosen band by means of screwdriver or pliers with care of not damaging boot.

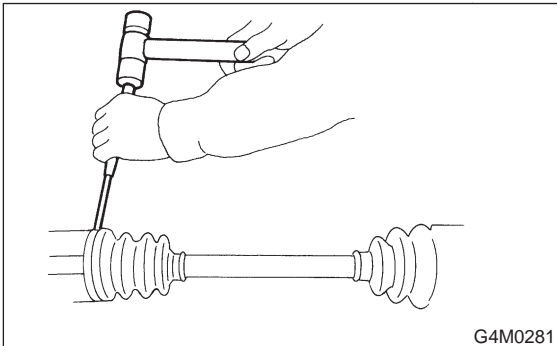

3) Remove boot band on the small end of DOJ boot in the same manner.

4) Remove the larger end of DOJ boot from DOJ outer race.

5) Pry and remove round circlip located at the neck of DOJ outer race with a screwdriver.

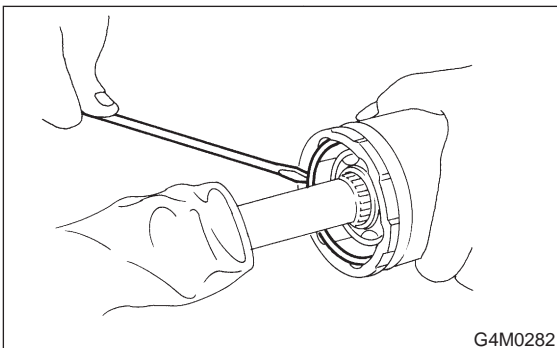

6) Take out DOJ outer race from shaft assembly.

7) Wipe off grease and take out balls.

CAUTION:

The grease is a special grease (grease for constant velocity joint). Do not confuse with other greases.

NOTE:

Disassemble exercising care not to lose balls (6 pcs).

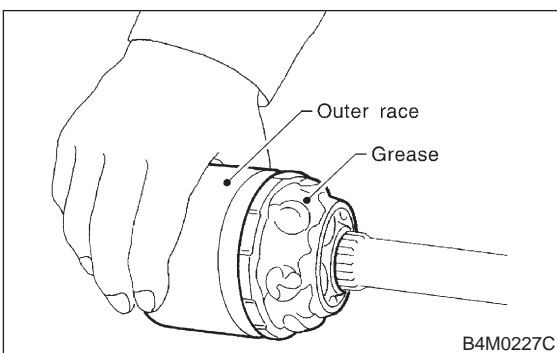

8) To remove the cage from the inner race, turn the cage by a half pitch to the track groove of the inner race and shift the cage.

9) Remove snap ring, which fixes inner race to shaft, by using pliers.

10) Take out DOJ inner race.

11) Take off DOJ cage from shaft and remove DOJ boot.

CAUTION:

Be sure to wrap shaft splines with vinyl tape to prevent boot from scratches.

12) Remove BJ boot in the same procedure as DOJ boot.

13) Thus, disassembly of axle is completed, but BJ is unable to be disassembled.

C: INSPECTION

Check the removed parts for damage, wear, corrosion etc. If faulty, repair or replace.

1) DOJ (Double Offset Joint)

Check seizure, corrosion, damage, wear and excessive play.

2) SFJ (Shudder-less Freering tripod Joint)

Check seizure, corrosion, damage and excessive play.

3) Shaft

Check excessive bending, twisting, damage and wear.

4) BJ (Bell Joint)

Check seizure, corrosion, damage and excessive play.

5) Boot

Check for wear, warping, breakage or scratches.

6) Grease

Check for discoloration or fluidity.

D: ASSEMBLY

1. FRONT DRIVE SHAFT

CAUTION:

Use specified grease.

BJ side:

NTG2218 (Part No. 28093AA020)

SFJ side:

SSG-6003 (Part No. 28093TA000)

1) Place BJ boot and small boot band on BJ side of shaft.

CAUTION:

Be sure to wrap shaft splines with vinyl tape to prevent boot from scratches.

2) Place drive shaft in a vise.

CAUTION:

Do not place drive shaft directly in the vise; use wooden blocks.

3) Apply a coat of specified grease [60 to 70 g (2.12 to 2.47 oz)] to BJ.

4) Apply an even coat of specified grease [20 to 30 g (0.71 to 1.06 oz)] to the entire inner surface of boot. Also apply grease to shaft.

NOTE:

The inside of the larger end of BJ boot and the boot groove shall be cleaned so as to be free from grease and other substances.

5) Install boot projecting portion to BJ groove.

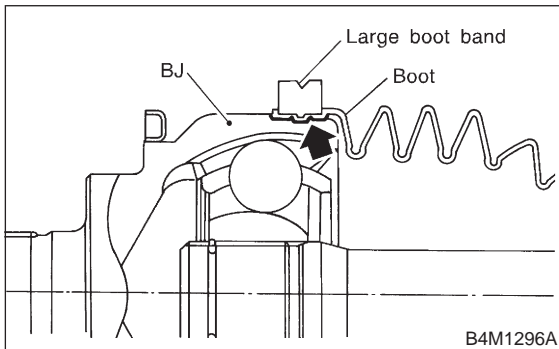

6) Set large boot band in place.
7) Install boot projecting portion to shaft groove.

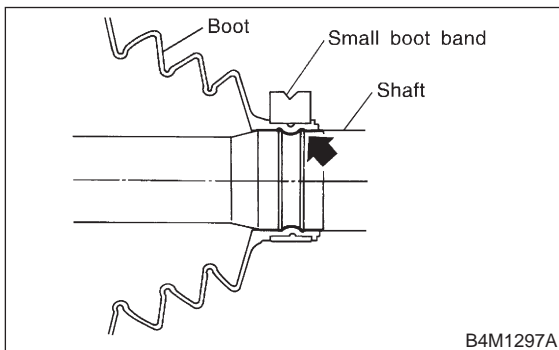

8) Tighten boot bands using ST, torque wrench and socket flex handle.

ST 28099AC000 BOOT BAND PLIER

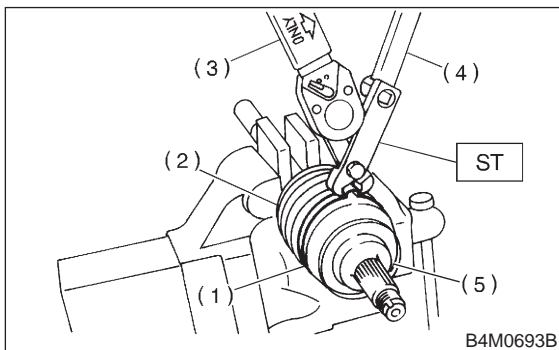

- (1) Large boot band
- (2) Boot
- (3) Torque wrench
- (4) Socket flex handle
- (5) BJ

Tightening torque:

Large boot band

157 N·m (16.0 kg·m, 116 ft·lb) or more

Small boot band

133 N·m (13.6 kg·m, 98 ft·lb) or more

9) Place SFJ boot at the center of shaft.
10) Align alignment marks and install trunnion on shaft.

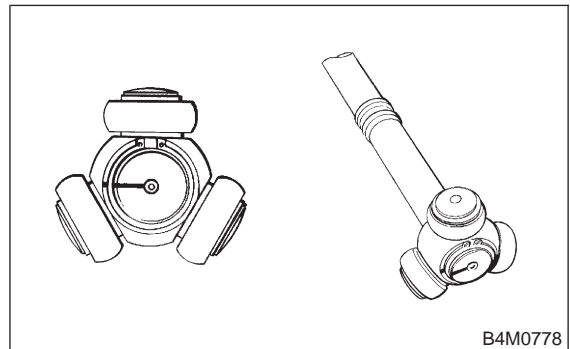

11) Install snap ring to shaft.

CAUTION:

Confirm that the snap ring is completely fitted in the shaft groove.

12) Fill 100 to 110 g (3.53 to 3.88 oz) of specified grease into the interior of SFJ outer race.

13) Apply a coat of specified grease to free ring and trunnion.

14) Align alignment marks on free ring and trunnion and install free ring.

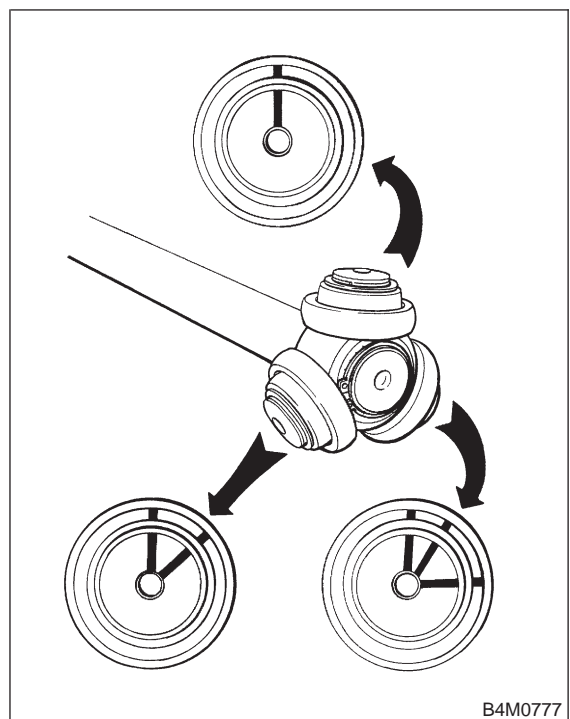

4-2 [W3D2]

3. Front and Rear Drive Shafts

SERVICE PROCEDURE

15) Align alignment marks on shaft and outer race, and install outer race.

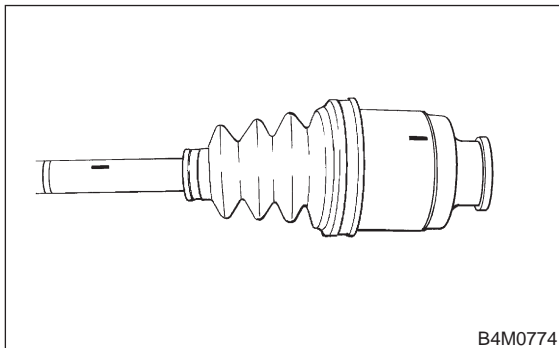

16) Install circlip in the groove on SFJ outer race.

CAUTION:

Pull the shaft lightly and assure that the circlip is completely fitted in the groove.

17) Apply an even coat of the specified grease 30 to 40 g (1.06 to 1.41 oz) to the entire inner surface of boot.

18) Install SFJ boot taking care not to twist it.

CAUTION:

- The inside of the larger end of SFJ boot and the boot groove shall be cleaned so as to be free from grease and other substances.
- When installing SFJ boot, position outer race of SFJ at center of its travel.

19) Put a band through the clip and wind twice in alignment with band groove of boot.

CAUTION:

Use a new band.

20) Pinch the end of band with pliers. Hold the clip and tighten securely.

NOTE:

When tightening boot, exercise care so that the air within the boot is appropriate.

21) Tighten band by using ST.

ST 925091000 BAND TIGHTENING TOOL

NOTE:

Tighten band until it cannot be moved by hand.

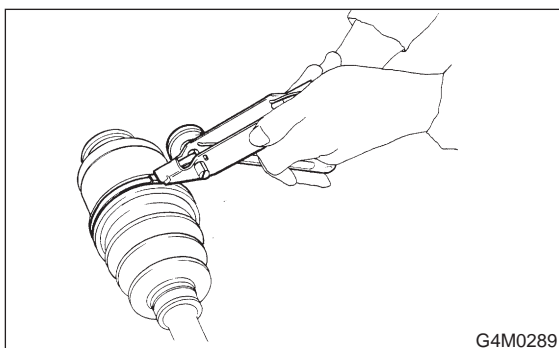

22) Tap on the clip with the punch provided at the end of ST.

ST 925091000 BAND TIGHTENING TOOL

CAUTION:

Tap to an extent that the boot underneath is not damaged.

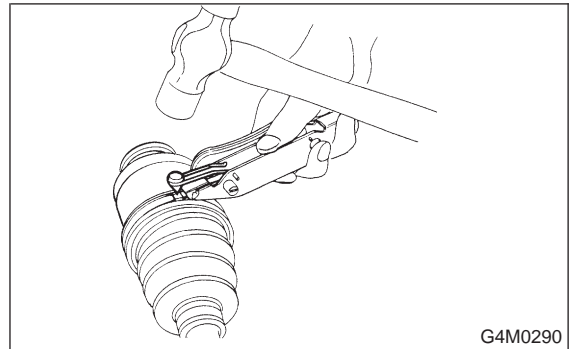

23) Cut off band with an allowance of about 10 mm (0.39 in) left from the clip and bend this allowance over the clip.

CAUTION:

Be careful so that the end of the band is in close contact with clip.

24) Fix up boot on BJ in the same manner.

NOTE:

Extend and retract SFJ to provide equal grease coating.

2. REAR DRIVE SHAFT

CAUTION:

Use specified grease.

BJ side:

Molylex No. 2 (Part No. 723223010) or Sunlight TB2-A

DOJ side:

VU-3A702 (Yellow) (Part No. 23223GA050)

1) Install BJ boot in specified position, and fill it with 60 to 70 g (2.12 to 2.47 oz) of specified grease.

2) Place DOJ boot at the center of shaft.

CAUTION:

Be sure to wrap shaft splines with vinyl tape to prevent boot from scratches.

3) Insert DOJ cage onto shaft.

NOTE:

Insert the cage with the cut-out portion facing the shaft end, since the cage has an orientation.

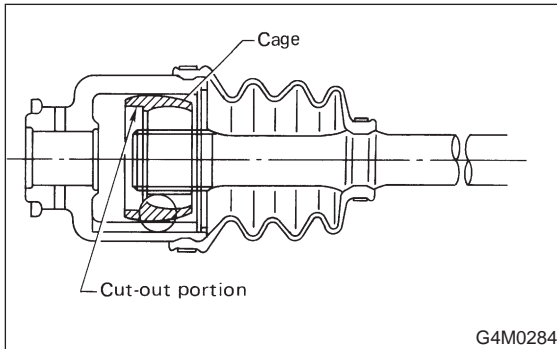

4) Install DOJ inner race on shaft and fit snap ring with pliers.

NOTE:

Confirm that the snap ring is completely fitted in the shaft groove.

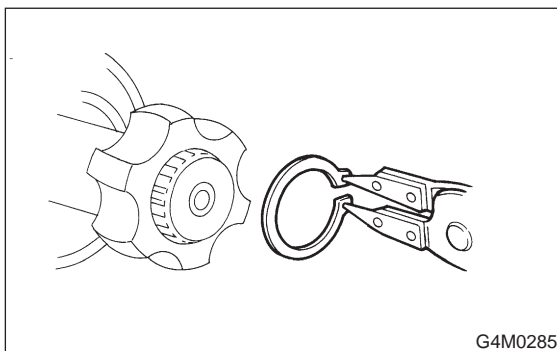

5) Install cage, which was previously fitted, to inner race fixed upon shaft.

NOTE:

Fit the cage with the protruded part aligned with the track on the inner race and then turn by a half pitch.

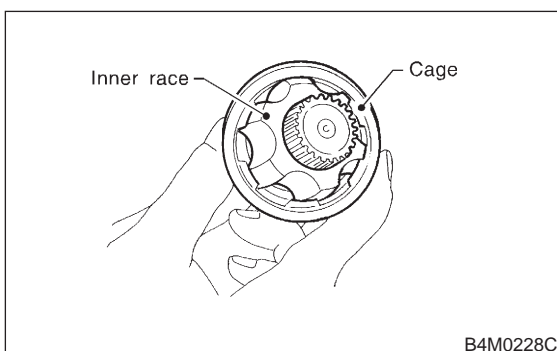

6) Fill 80 to 90 g (2.82 to 3.17 oz) of specified grease into the interior of DOJ outer race.

7) Apply a coat of specified grease to the cage pocket and six balls.

8) Insert six balls into the cage pocket.

9) Align the outer race track and ball positions and place in the part where shaft, inner race, cage and balls are previously installed, and then fit outer race.

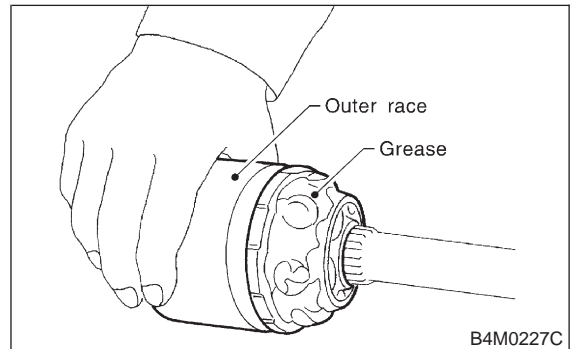

10) Install circlip in the groove on DOJ outer race.

NOTE:

- Assure that the balls, cage and inner race are completely fitted in the outer race of DOJ.
- Exercise care not to place the matched position of circlip in the ball groove of outer race.
- Pull the shaft lightly and assure that the circlip is completely fitted in the groove.

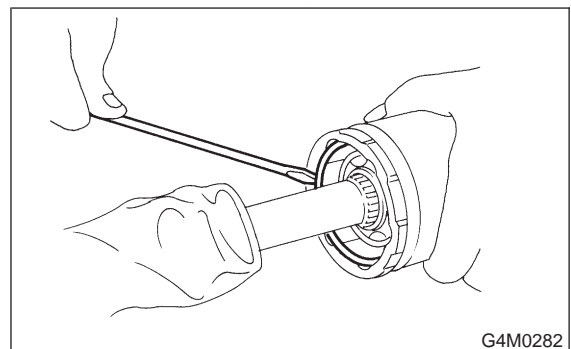

11) Apply an even coat of the specified grease [20 to 30 g (0.71 to 1.06 oz)] to the entire inner surface of boot. Also apply grease to shaft.

12) Install DOJ boot taking care not to twist it.

NOTE:

- The inside of the larger end of DOJ boot and the boot groove shall be cleaned so as to be free from grease and other substances.
- When installing DOJ boot, position outer race of DOJ at center of its travel.

13) Put a band through the clip and wind twice in alignment with band groove of boot.

CAUTION:

Use a new band.

4-2 [W3E1]

3. Front and Rear Drive Shafts

SERVICE PROCEDURE

14) Pinch the end of band with pliers. Hold the clip and tighten securely.

NOTE:

When tightening boot, exercise care so that the air within the boot is appropriate.

15) Tighten band by using ST.

ST 925091000 BAND TIGHTENING TOOL

NOTE:

Tighten band until it cannot be moved by hand.

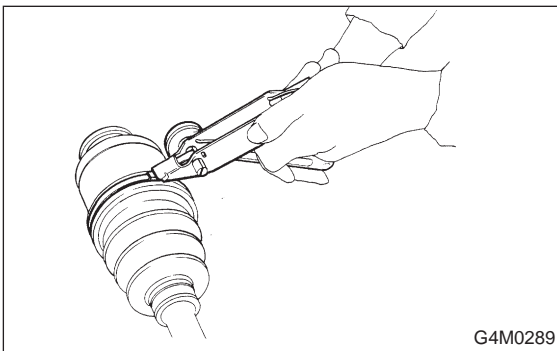

16) Tap on the clip with the punch provided at the end of ST.

ST 925091000 BAND TIGHTENING TOOL

CAUTION:

Tap to an extent that the boot underneath is not damaged.

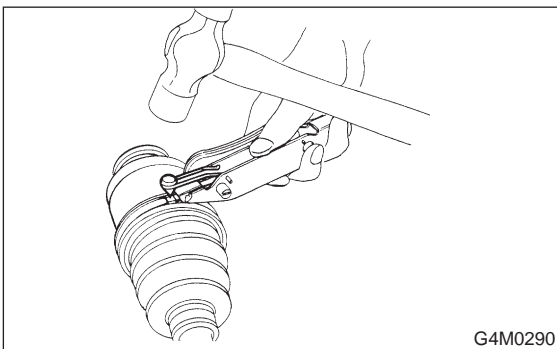

17) Cut off band with an allowance of about 10 mm (0.39 in) left from the clip and bend this allowance over the clip.

CAUTION:

Be careful so that the end of the band is in close contact with clip.

18) Fix up boot on BJ in the same manner.

NOTE:

Extend and retract DOJ to provide equal grease coating.

E: INSTALLATION

1. FRONT DRIVE SHAFT

1) Insert BJ into hub splines.

CAUTION:

Be careful not to damage inner oil seal lip.

2) Using ST1 and ST2, pull drive shaft into place.

ST1 922431000 AXLE SHAFT INSTALLER

ST2 927390000 ADAPTER

CAUTION:

Do not hammer drive shaft when installing it.

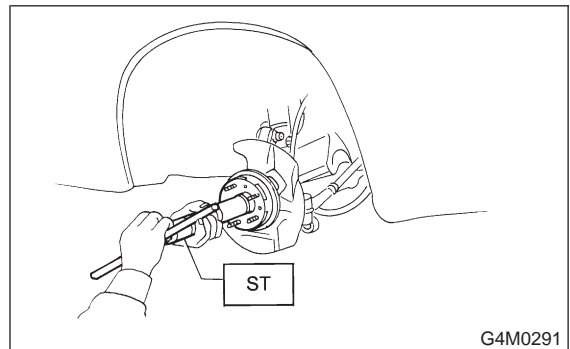

3) Tighten axle nut temporarily.

4) Install SFJ on transmission spindle and drive spring pin into place.

CAUTION:

Always use a new spring pin.

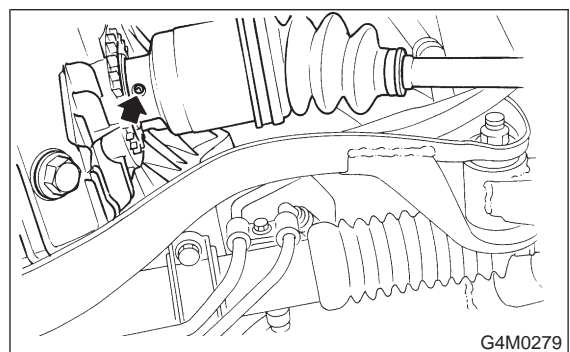

5) Connect transverse link to housing.

Torque (self-locking nut):

49 ± 10 N-m (5.0 ± 1.0 kg-m, 36 ± 7 ft-lb)

CAUTION:

Use a new self-locking nut.

6) Install stabilizer bracket.

7) While depressing brake pedal, tighten axle nut to the specified torque.

Tightening torque:

186 ± 20 N-m (19 ± 2 kg-m, 137 ± 14 ft-lb)

CAUTION:

- Use a new axle nut.
- Always tighten axle nut before installing wheel on vehicle. If wheel is installed and comes in contact with ground when axle nut is loose, wheel bearings may be damaged.
- Be sure to tighten axle nut to specified torque. Do not overtighten it as this may damage wheel bearing.

8) After tightening axle nut, lock it securely.

2. REAR DRIVE SHAFT

1) Insert BJ into rear housing splines.

CAUTION:

Be careful not to damage inner oil seal lip.

2) Using ST1 and ST2, pull drive shaft into place.

ST1 922431000 AXLE SHAFT INSTALLER

ST2 927390000 ADAPTER

CAUTION:

Do not hammer drive shaft when installing it.

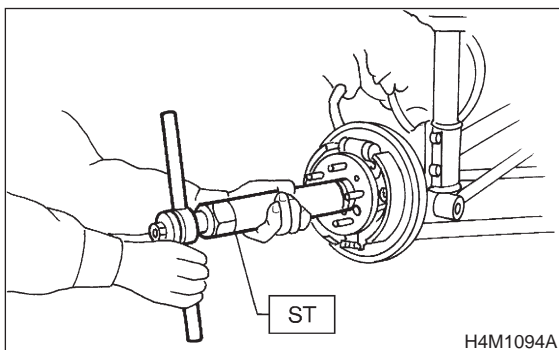

- 3) Tighten axle nut temporarily.
- 4) Replace circlips from DOJ spline with new one. (2200 cc AT model only)
- 5) Using ST, install DOJ into differential.

ST 28099PA090 SIDE OIL SEAL PROTECTOR

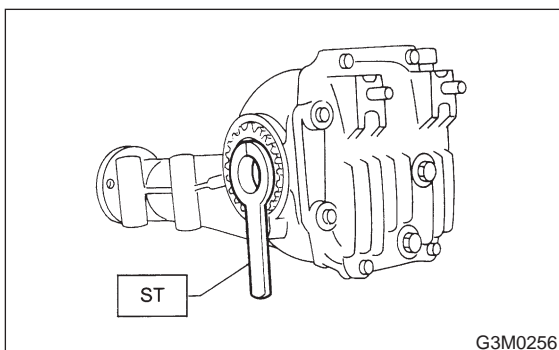

6) Insert DOJ spline end into bore of side oil seal, and remove ST.

CAUTION:

Do not allow DOJ splines to damage side oil seal.

ST 28099PA090 SIDE OIL SEAL PROTECTOR

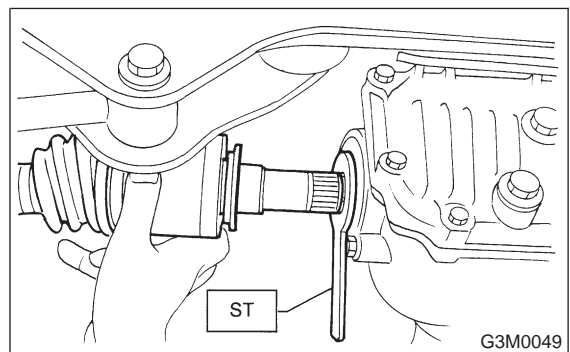

- 7) Align DOJ and differential splines.
- 8) Push housing to insert DOJ into differential.

NOTE:

Make sure DOJ is inserted properly.

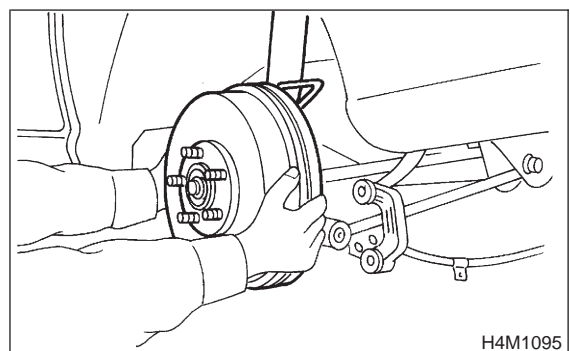

9) Connect rear housing assembly to trailing link assembly, and tighten self-locking nut.

Tightening torque:

113±15 N·m (11.5±1.5 kg·m, 83±11 ft·lb)

10) Connect rear housing assembly to lateral link assembly, and tighten self-locking nut.

Tightening torque:

137±20 N·m (14±2 kg·m, 101±14 ft·lb)

11) Install stabilizer bracket.

12) While depressing brake pedal, tighten axle nut using a socket wrench.

Tightening torque:

186±20 N·m (19±2 kg·m, 137±14 ft·lb)

CAUTION:

- Use a new axle nut.
- Always tighten axle nut before installing wheel on vehicle. If wheel is installed and comes in contact with ground when axle nut is loose, wheel bearings may be damaged.
- Be sure to tighten axle nut to specified torque. Do not overtighten it as this may damage wheel bearing.

13) After tightening axle nut, lock it securely.

4. Full Wheel Cap

A: REMOVAL

Pry off the full wheel cap with a wheel cap remover inserted between openings in the cap.

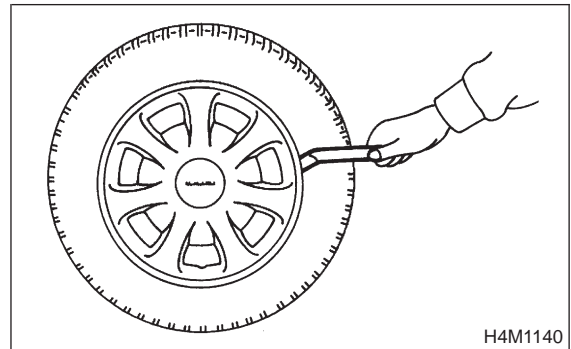

B: INSTALLATION

Align the valve hole in the wheel cap with the valve on the wheel and secure the wheel cap by tapping four points by hand.