

8. Tire Rotation

If tires are maintained at the same positions for a long period of time, uneven wear results. Therefore, they should be periodically rotated. This lengthens service life of tires.

CAUTION:

When rotating tires, replace unevenly worn or damaged tires with new ones.

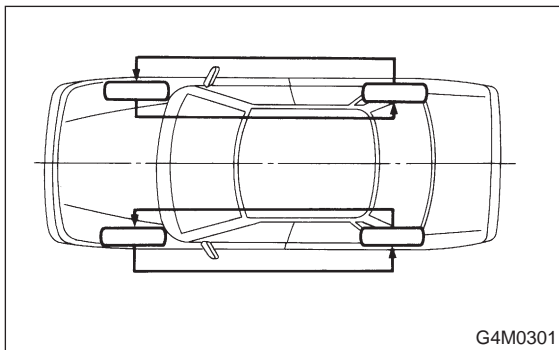

9. "T-type" Tire

"T-type" tire for temporary use is prepared as a spare tire.

CAUTION:

- Keep the inflation pressure at 412 kPa (4.2 kg/cm², 60 psi) at all times.
- When the wear indicator appears on the tread surface, replace the tire with a new one.
- Do not use a tire chain with the "T-type" tire. Because of the smaller tire size, a tire chain will not fit properly and will result in damage to the vehicle and the tire.
- Do not drive at a speed greater than 80 km/h (50 MPH).
- Drive as slowly as possible and avoid passing over bumps.
- Replace with a conventional tire as soon as possible since this "T-type" tire is only for temporary use.