

1. Torque Converter Clutch and Case

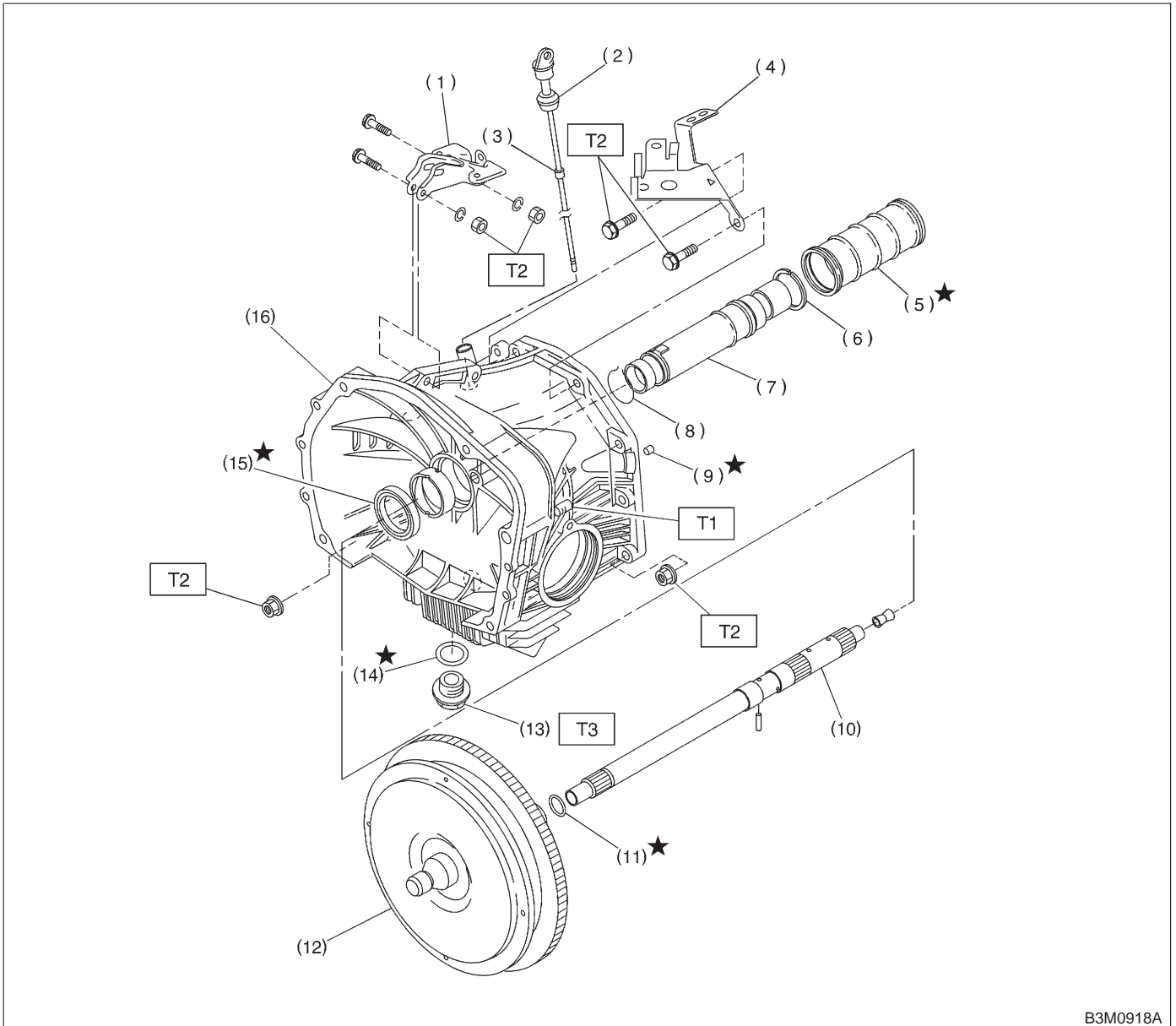

B3M0918A

- | | |
|----------------------------------|-----------------------------------|
| (1) Pitching stopper bracket | (9) Oil drain pipe |
| (2) O-ring | (10) Input shaft |
| (3) Differential oil level gauge | (11) O-ring |
| (4) Stay | (12) Torque converter clutch |
| (5) Seal pipe | (13) Drain plug |
| (6) Seal ring | (14) Gasket |
| (7) Oil pump shaft | (15) Oil seal |
| (8) Clip | (16) Torque converter clutch case |

Tightening torque: N-m (kg-m, ft-lb)

T1: 18±5 (1.8±0.5, 13.0±3.6)

T2: 41±3 (4.2±0.3, 30.4±2.2)

T3: 44±3 (4.5±0.3, 32.5±2.2)