

19. Differential Case Assembly

A: DISASSEMBLY

1) Using a press and ST, remove the taper roller bearing.

ST 498077000 REMOVER

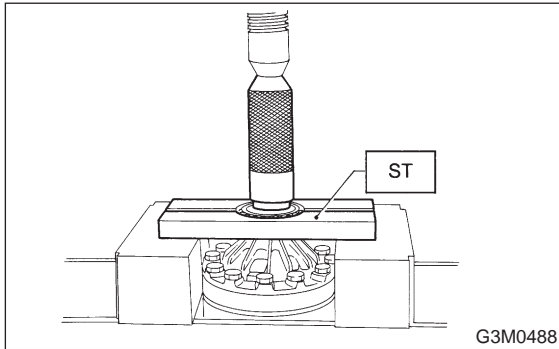

2) Secure the case in a vise and remove the crown gear tightening bolts, then separate the crown gear, case (RH) and case (LH).

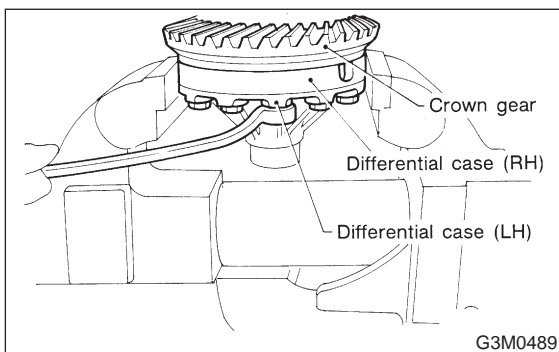

3) Pull out the straight pin and shaft, and remove the differential bevel gear, washer, and differential bevel pinion.

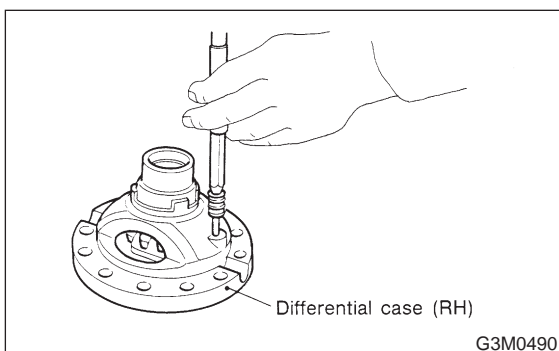

B: INSPECTION

Check each component for harmful cuts, damage and other faults.

C: ASSEMBLY

1) Install the washer, differential bevel gear and differential bevel pinion in the differential case (RH). Insert the pinion shaft, and fit the straight pin.

NOTE:

Install straight pin from reverse direction.

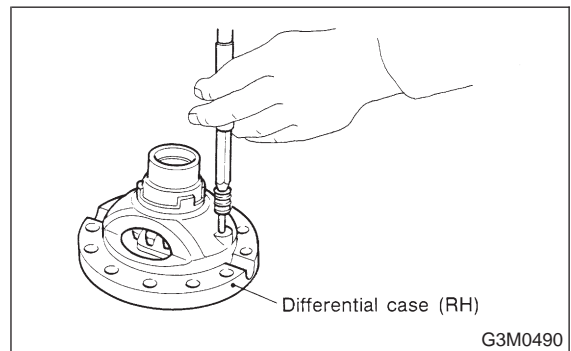

2) Install the washer and differential bevel gear to the differential case (LH). Then put the case over the differential case (RH), and connect both cases.

3) Install the crown gear and secure by tightening the bolt.

Standard tightening torque:

62±5 N·m (6.3±0.5 kg·m, 45.6±3.6 ft·lb)

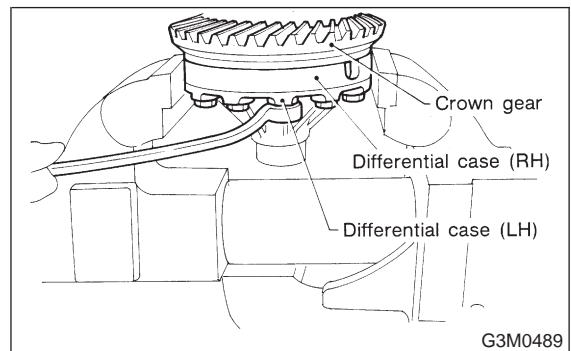

- 4) Measurement of backlash (Selection of washer)
Measure the gear backlash with ST1 and ST2, and insert ST2 through the access window of the case.
ST1 498247001 MAGNET BASE
ST2 498247100 DIAL GAUGE

NOTE:

Measure the backlash by applying a pinion tooth between two bevel gear teeth.

Standard value:

0.13 — 0.18 mm (0.0051 — 0.0071 in)

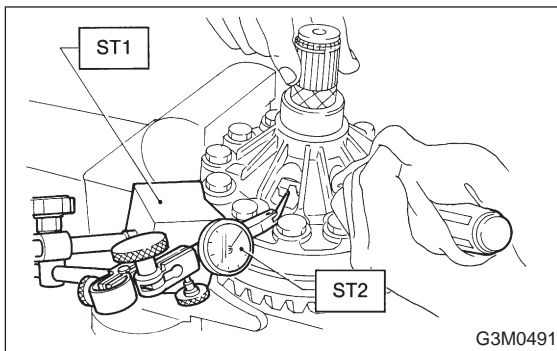

- 5) Using ST, install taper roller bearing.
ST 398487700 DRIFT

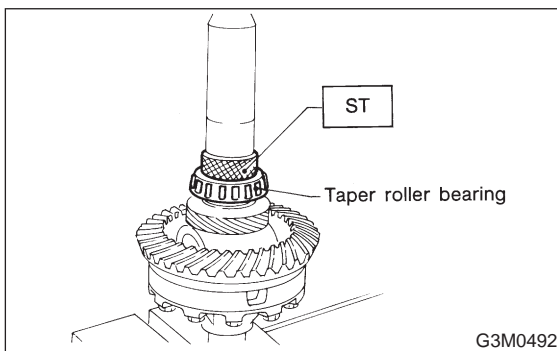

20. Transfer Clutch

A: DISASSEMBLY

- 1) Remove the seal ring.

CAUTION:

Be careful not to damage the seal ring.

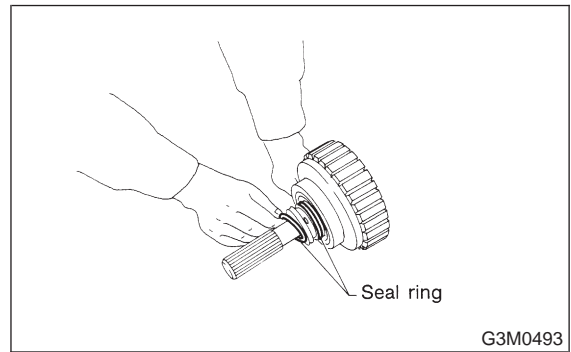

- 2) Using a press and ST, remove the ball bearing.

CAUTION:

Do not reuse the bearing.

ST 498077600 REMOVER

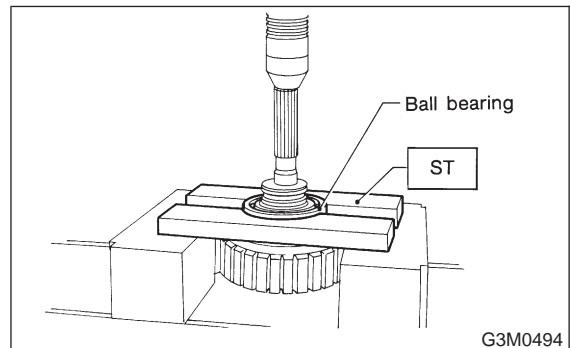

- 3) Remove the snap ring, and take out the pressure plate, drive plates, and driven plates.

