

3-2 [W15A0]

15. Oil Pump Assembly

SERVICE PROCEDURE

7) Tighten bolts.

Tightening torque:

8 ± 1 N-m (0.8 ± 0.1 kg-m, 5.8 ± 0.7 ft-lb)

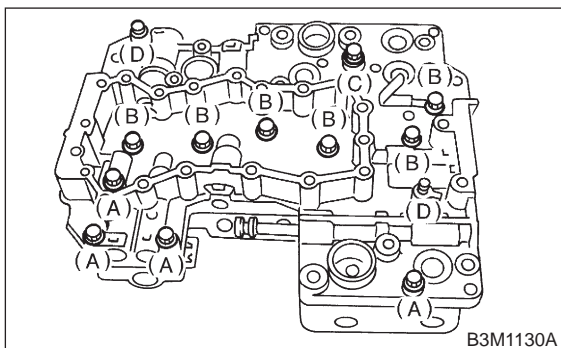

- (A) Short bolts
- (B) Middle bolts
- (C) Long bolt
- (D) Reamer bolts

8) Install the sensor, solenoids and duty solenoid S.

Tightening torque:

$T: 8\pm 1$ N-m (0.8 ± 0.1 kg-m, 5.8 ± 0.7 ft-lb)

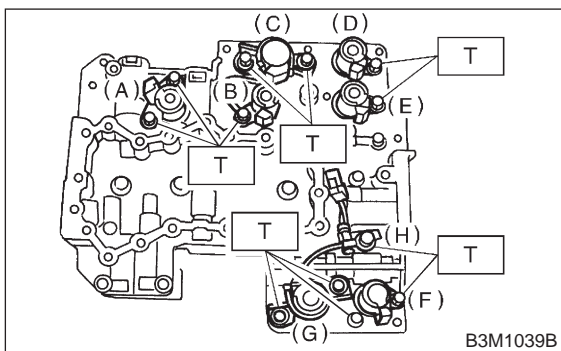

- (A) Lock-up duty solenoid (Blue)
- (B) Low clutch timing solenoid (Gray)
- (C) Line pressure duty solenoid (Red)
- (D) Shift solenoid 1 (Yellow)
- (E) Shift solenoid 2 (Green)
- (F) 2-4 brake timing solenoid (Black)
- (G) 2-4 brake duty solenoid D (Red)
- (H) ATF temperature sensor

9) Install oil strainer to lower valve body.

Tightening torque:

8 ± 1 N-m (0.8 ± 0.1 kg-m, 5.8 ± 0.7 ft-lb)

15. Oil Pump Assembly

A: DISASSEMBLY

1) Remove the oil seal retainer.
Also remove the O-ring and oil seal (air breather).

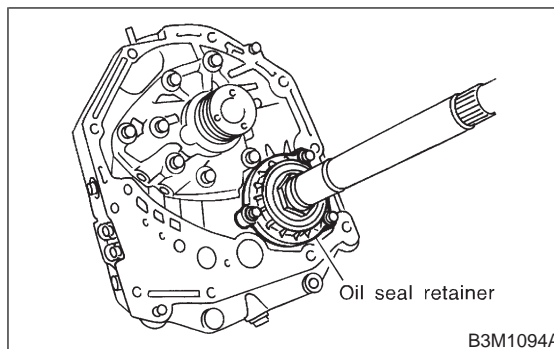

2) Remove O-rings from oil pump housing.

CAUTION:
Be careful not to damage O-ring.

3) Remove four seal rings.

CAUTION:
Be careful not to damage O-ring.

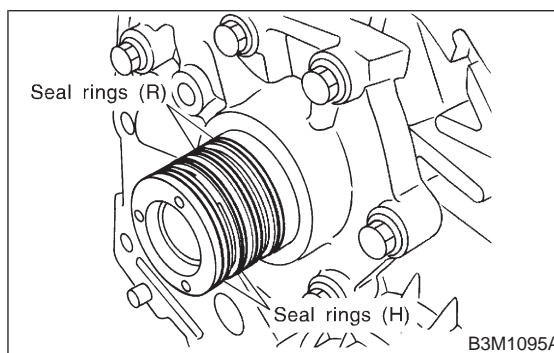

4) Remove the oil pump cover.

NOTE:
Lightly tap the end of the stator shaft to remove the cover.

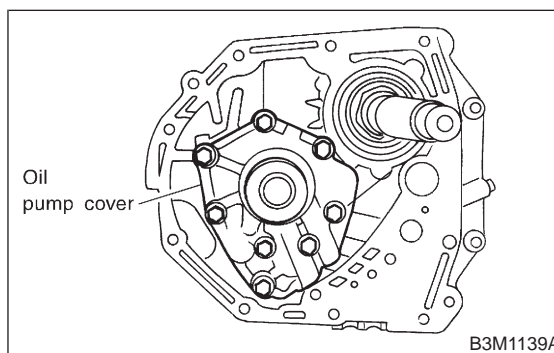

5) Remove the inner and outer rotor.

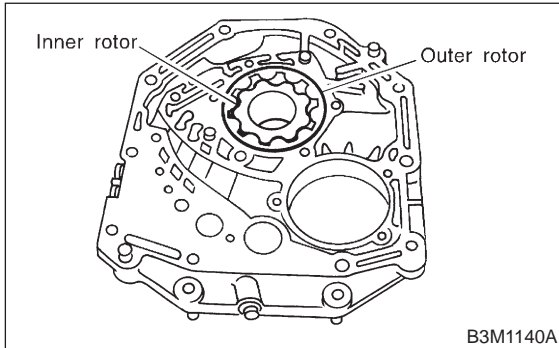

B: INSPECTION

- 1) Check seal ring and O-ring oil seal for breaks or damage.
- 2) Check other parts for dents or abnormalities.
- 3) Selection of oil pump rotor assembly
 - (1) Tip clearance
Install inner rotor and outer rotor to oil pump.
With rotor gears facing each other, measure crest-to-crest clearance.

Tip clearance:
0.02 — 0.15 mm (0.0008 — 0.0059 in)

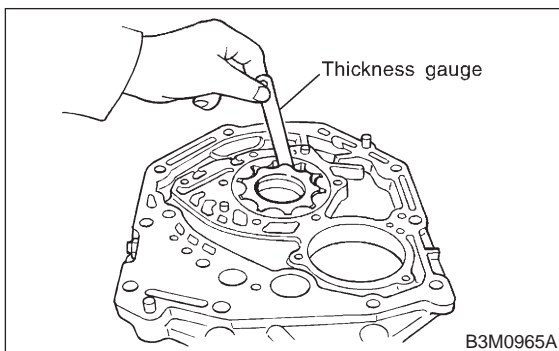

- (2) Side clearance
Set a depth gauge to oil pump housing, then measure oil pump housing-to-rotor clearances.

Side clearance:
0.02 — 0.04 mm (0.0008 — 0.0016 in)

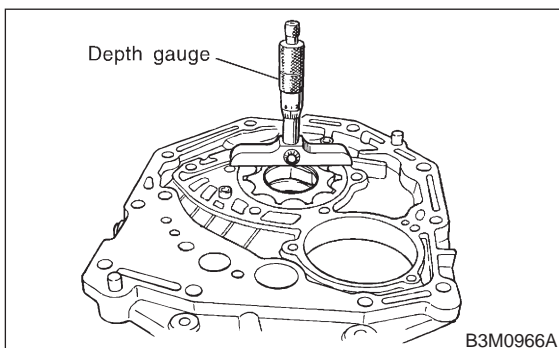

- (3) If depth and/or side clearances are outside specifications, replace rotor assembly.

| Oil pump rotor assembly | |
|-------------------------|---------------------------------|
| Part No. | Thickness mm (in) |
| 15008AA060 | 11.37 — 11.38 (0.4476 — 0.4480) |
| 15008AA070 | 11.38 — 11.39 (0.4480 — 0.4484) |
| 15008AA080 | 11.39 — 11.40 (0.4484 — 0.4488) |

C: ASSEMBLY

- 1) Install oil pump rotor assembly to oil pump housing.

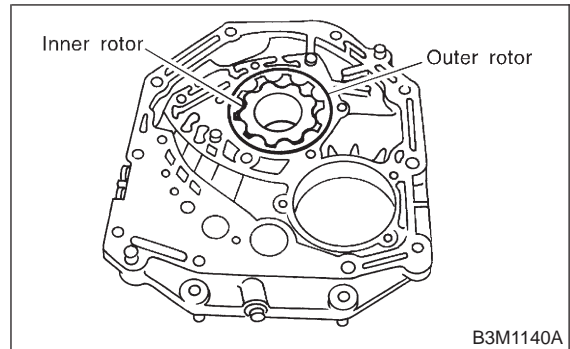

- 2) Install the oil pump cover.

Tightening torque:
25±2 N·m (2.5±0.2 kg·m, 18.1±1.4 ft·lb)

NOTE:

- Align both pivots with the pivot holes of the cover, and install the cover being careful not to apply undue force to the pivots.
- After assembling, turn the oil pump shaft to check for smooth rotation of the rotor.

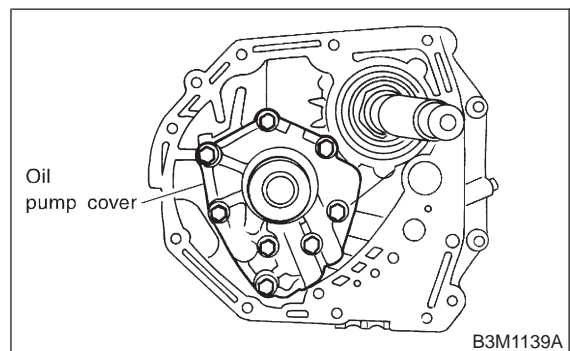

- Install the oil seal retainer and seal rings. After adjusting the drive pinion backlash and tooth contact.

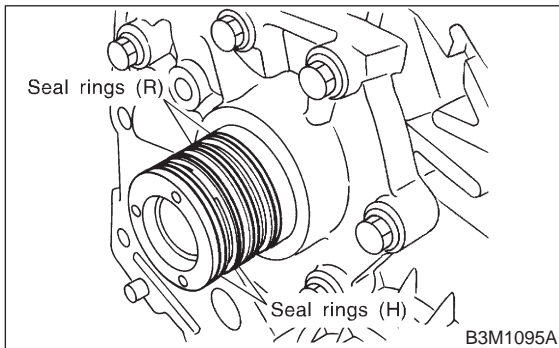

16. Drive Pinion Shaft

A: DISASSEMBLY

- 1) Straighten the staked portion of the lock nut, and remove the lock nut while locking the rear spline portion of the shaft with ST1 and ST2. Then pull off the drive pinion collar.

- ST1 498937100 HOLDER
- ST2 499787100 WRENCH
- ST3 499787500 ADAPTER

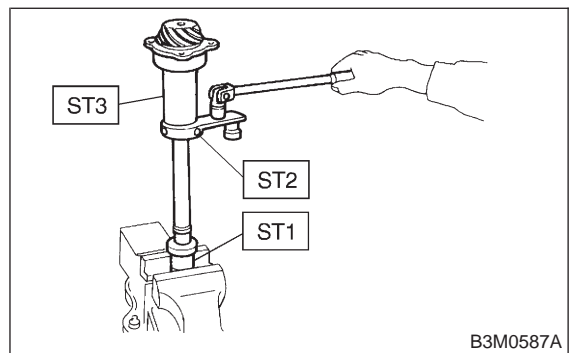

- 2) Remove the O-ring.
- 3) Using a press, separate the rear roller bearing and outer race from the shaft.

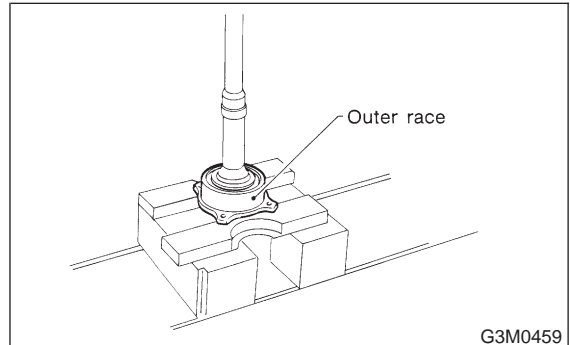

- 4) Using a press and ST, separate the front roller bearing from the shaft.

- ST 498517000 REPLACER

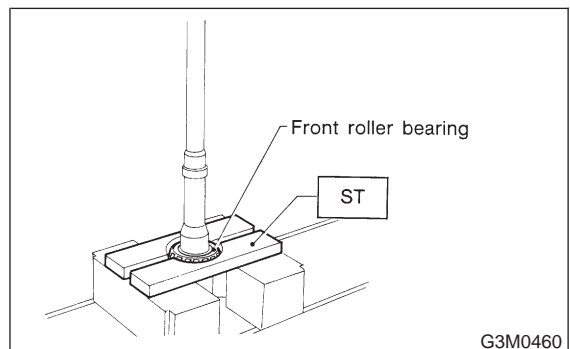

B: INSPECTION

Make sure that all component parts are free of harmful cuts, gouges, and other faults.